

Mini Portable Thermal Printer-MP300

User Manual



Contents

NOTES.....	错误! 未定义书签。
一 DESCRIPTION	5
1.1 APPEARANCE.....	5
1.3 ACCESSORY	6
二 FEATURES.....	7
2.1 PRINT FEATURES.....	7
2.2 PHYSICAL PARAMETERS	7
2.3 ENVIROMENT PARAMETERS	7
2.3 OTHER PARAMETERS	7
三 USE METHODS.....	8
3.1 PREPARING FOR USE	8
3.1.1 <i>battery installation</i>	8
3.1.2 <i>installation of the print paper roll</i>	8
3.2 BASIC FUNCTIONS	9
3.2.1 <i>power on</i>	9
3.2.2 <i>power off</i>	9
3.2.3 <i>self test</i>	9
3.2.4 <i>feeding (manual feed)</i>	9
3.2.5 <i>charge</i>	9
3.3 PRINT CONNECTION AND PRINT	10
3.3.1 <i>serial port</i>	10
3.3.2 <i>the original IR and IrDA connection</i>	10
3.3.3 <i>bluetooth pairing and print</i>	11
3.4 LIGHT AND BUZZER SIGNAL DESCRIPTION.....	11
四 OTHER INFORMATION	12
4.1 PRINTER DEVELOPMENT GUIDE	12
4.2 PRE-PRINTED BLACK MARK INSTRUCTION.....	12

Attentions

Please read this document before using the printer !

Safety attention

This printer can use special charger and power adapter only provided by the company. Or there will cause product damage, battery leakage, fire even explosion.

Don't put the battery to fire. Don't make the battery short circuit, demolition heating, or it maybe battery leakage, fire even explosion.

Fluid in battery has causticity. If operate inadvertently causing battery leaks and the liquid stick to skin or clothes, please use water to wash immediately. If entering eye accidently, please use plenty of water to wash eyes and go to see a doctor. Don't open the paper cover, touch printer-core when printing or just printed. In order to avoid burns cased by high temperature.

Don't use the printer when malfunctioning. It may cause fire or electric shock.

Switch off and unplug the printer then call your dealer.

Attentions in using

Neither immersed the printer in water nor prolonged exposure to rain, or it may cause damage to the printer.

Don't open the paper cover when printing, or it may cause the printer work not properly.

Can't unplug the serial cable when printing in serial port. Or printed data will not be complete.

Please align the master's IR window to the printer's IR window when printing in IR mode. Distance can't exceed 50cm, angle can't exceed 30 degrees, or may cause garbled or can't print.

Although printer can work stable with -10°C to 50°C, but too high environment temperature or low temperature may reduce print quality.

Too high humidity(>85%) or too low humidity (<20%) will reduce print quality.

Using poor quality printing paper or store paper too long time may reduce printing quality even damage the printer.

When printer working in black mark detection method ,requiring black label that pre-printed in printing paper conform black label printing specifications. Or it may cause printer can't detect the black label accurately.

Attentions in storage

Store temperature: -20°C to 70°C. Humidity temperature: 5% to 95%.

Please remove the battery in a separate storage if store the printer for long time. Or it may lead to battery failure even leaking then damage the printer.

General thermal paper storage time is short. If you want to print document to save for long time ,please use the long-term thermal paper. Don't store paper in direct sunlight or heat. Please save in a cool dark place if you have opened.

■ Attention in battery safety

Please read this user manual before use product

May cause battery to overheat, fire, explosion, damage, performance or reduce product's life if ignore these instructions.

danger

1. Don't let water enter in battery. If burn security device inside the battery, battery charging may cause exception current or voltage, chemical reaction. Then even cause battery to overheat, ignite or explosion.
2. Don't use or store battery near high-temperature place. Excessive heat may damage resin enclosure and/or insulation materials, then short-circuit inside battery. Even lead battery overheat, fire and/or explosion.
3. Please use the special charger when charging. Charging in high temperature, high pressure/high current, using modified charger, etc. may cause over battery charging and abnormal current/voltage, chemical reaction. Then may cause battery overheat, fire and/or explosion.
4. Battery have marked positive and negative clearly. Please sure that battery orientation is correct when putting battery into the charger and/or product. Insert reversed will cause charge reversed, chemical reaction. Then may cause battery overheat, fire and/or explosion.
5. Don't contact battery and power outlet with cigarette lighter socket. It may cause hypertension, excessive current, battery to overheat, fire and/or explosion.
6. Don't heat battery or put battery in fire. This may melt insulation material, damage security device, ignite electrolytic solution, causing battery overheat, fire and/or explosion.
7. Don't use battery in opposite (+) and (-) orientation. In the charging process, this will cause reverse charge, abnormal chemical reaction. In the using process, may appear abnormal current that can't be predicted. Causing battery overheat, fire and/or explosion.
8. Don't let battery's positive and negative touch any metal. Don't carry or store battery with metal objects such as necklaces, hair clips, etc. Internal short-circuit may cause excessive current, cause battery overheat, fire and/or explosion and the adjacent metal objects may be overheating.
9. Don't throw or hit battery. If burned security device inside the battery, the battery charging may cause abnormal current and/or voltage, cause abnormal chemical reaction then may cause battery overheat, fire and/or explosion.

Part — Introduction

1.1 printer appearance

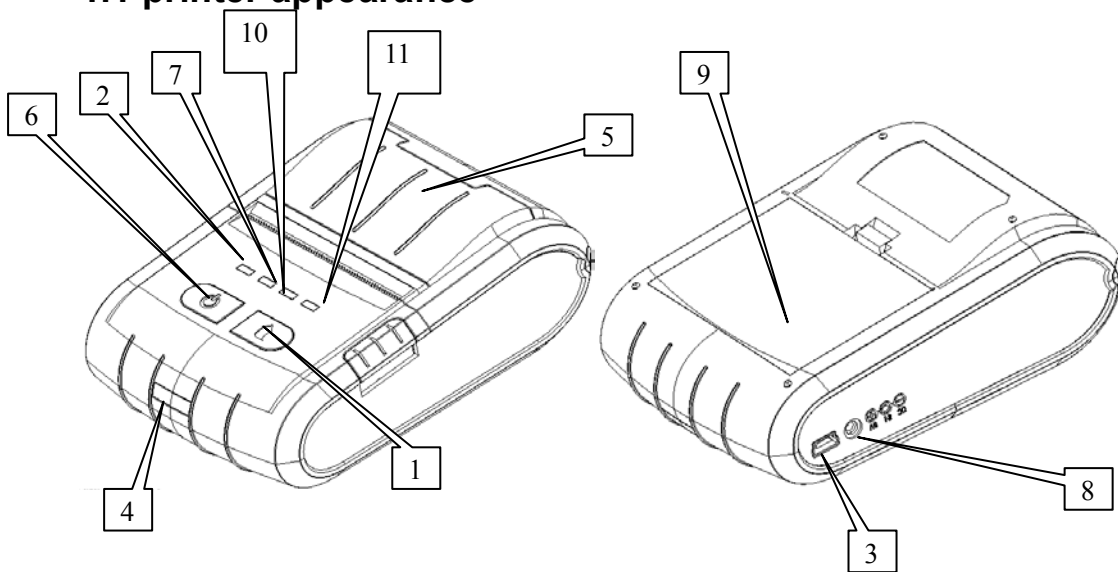

1. feed button
2. low paper indicator
3. RS232 serial communication socket
4. IR interface
5. printer cover
6. power button
7. system light
8. power interface
9. battery cover
10. charge indicator
11. Bluetooth connection indicator

1.3 Accessory

Standard accessories

battery

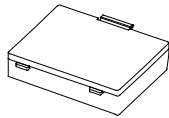

power charge

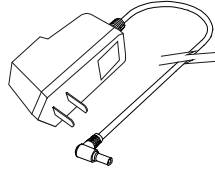

serial data line

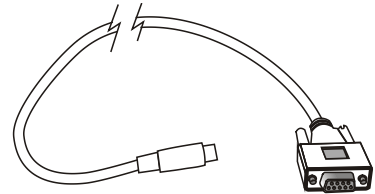

options

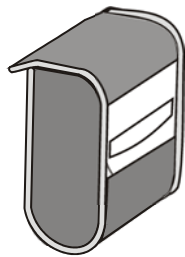

leather

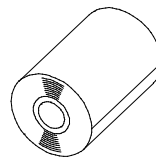

paper roll

Part 二 Features

2.1 printing performance

Print method: thermal printing

Paper width : 57mm;

Effective print width : 48mm

Resolution : 8 点/mm (203dpi) ;

Dots per line: 384 dots;

Print speed : 50~80mm/s;

Paper thickness : 60~80 μ m;

Printable content : English , members , symbols, characters, graphics, curve, pre-stored icons

Barcode(CODE39、EAN13、EAN8、 CODABAR、 CODE128、 CODE93、 ITF)

2.2 Physical parameters

Size : 114 * 85 * 38 mm;

Weight :205g (without paper roll) ;

Roll diameter : ≤30mm;

Interface method: original IR(RAW_IR),VIR, IrDA(Ir COMM),RS232 serial,Bluetooth ;

Interfaces are different by specific models. Look at model description.

2.3 Environment parameters

Work temperature: -10°C~50°C;

Work humidity : 20%~85%;

Store temperature : -20°C~70°C;

Store humidity : 5%~95%。

2.3 other performance

Paper loading method: clamshell paper loading;

Black label position: look at 4.2 pre-print black label instruction;

Paper detection: power button and function keys will flash and buzzer prompts when the printer runs out of paper.

Printing control commands: ECS/POS compatible instruction set.

Power supply method: 1600mAH lithium ion power.

Battery warning: when battery will consume, the charge indicator flashes and emit two short ringing. If user haven't charge, there will utter a ringing interval to prompt user to charge.

Charging : full charged within 2~4 hours.

Time of a single charge can be use: on 12.5% print density 100~200m, on 25% print density 80~100m. This parameter is only for reference. After using the battery for long time, may lead to decline capacity so that can't sure the print time.

≡ Using method

3.1 prepare before use

3.1.1 Battery installation

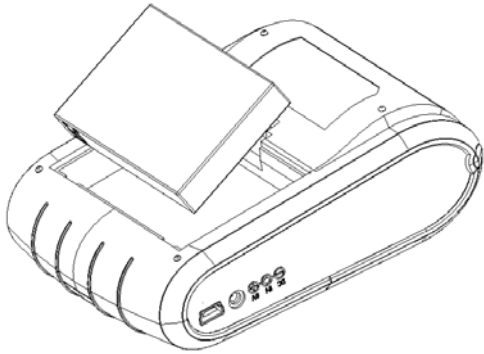

- 1、 Open the battery cover then open the battery compartment cover
- 2、 As shown, put battery into the battery cover. Notice that don't upside down the positive and negative.
- 3、 Then close the battery cover.

3.1.2 Install the print paper roll

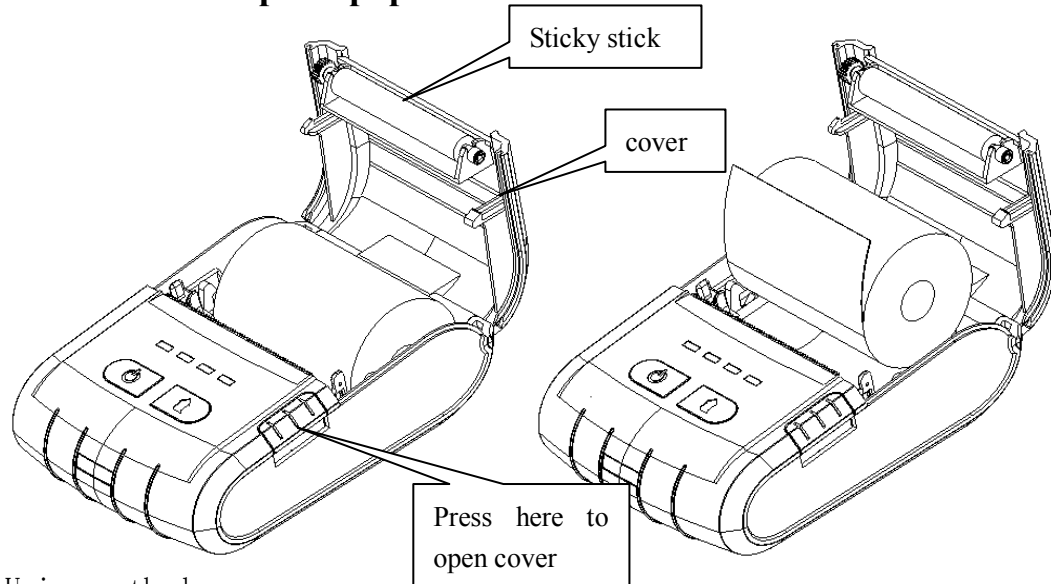

Using method

- 1、 Hold down the lid button, a little forced to open the cover;
- 2、 As shown put paper roll into the warehouse. Pay attention to the direction of paper. Upside will lead can't to print;
- 3、 As picture shown pull part of the paper. Notice to pull paper out of warehouse;
- 4、 Straighten the paper roll then close the cover.

3.2 Basic functions of using

3.2.1 Power on

When turn off, press power button **【POWER】** for 2 seconds, the printer turned on and entering working state. The power indicator (red light) flash.

Notice: If there isn't out of paper but feed light flashes that mean the printer is running out of power. Please replace the battery or charge to continue to use. Charging method is in 3.2.5(charge).

3.2.2 Power off

When power on, press power button **【POWER】** for 2 seconds, the printer turned off . All lights extinguish.

3.2.3 Self detection

User can detect printer any time to detect the printer current settings and status.

Self detection method: Power off (if the printer is turned on) , then press **【FEED】** , then press **【POWER】** to turn on. Printer will print self-test page with current status of the printer and printer setting and print example.

3.2.4 Feeding (manual feed)

In normal operation, press **【FEED】** to start feeding. Feeding 250mm if there have print black label in printing paper that printer recognized. Printer will stop feeding automatically when printer feed to black label. Printer feed will not affect by black label if set feeding length to 0.

3.2.5 Charger

The printer's battery will be consumed after using for a time. When battery power is going to run out, feed light will blink and issue a warning sound. It means it's time to charge. User have to charge when printer turned off automatically in printing process such as to continue to use.

Charge as follow: Insert the charger's mains plug to electrical outlet of 220V、50HZ. Then insert charge plug into the charging socket begin to charge.

In charging, feed light will flash and charge indicator always flash until the battery is full charged in power on status.

You can use the printer normally in charging process.

3.3 Print connection and print

3.3.1 Serial port connection

Optional accessories of printer contain DB-9 serial cable (other end MINI DIN plug connect the printer).

3.3.2 Original infrared and IrDA connectivity

IR data communication technology can be used to data communicate with your equipment.

IR data communication technology is a kind of wireless data communication technology which is use IR as a communication carrier that develop and developed by IR Data Association (IrDA).

Using method

IR port, wireless data transmission interface, now has been the main means of data communication for most of portable devices because of its low power consumption, mature technology, easy to use and exp. Most of portable devices have IR port such as all of the WINCE Pocket PC, PALM PDA, notebook computers, some mobile phones, most of portable data collector and a small part of measuring instruments that used in field operations.

The printer's hardware compatible IrDA1.1 specifications. IrCOMM protocol is a sub-agreement of IrDA protocol. It has used in many portable devices. Original IR data communication method can connect device that has original IR interface to print. IrCOMM ways can connect IrCOMM protocol device to print. More knowledge about IrDA please visit <http://www.irda.org>.

Printer can't work at original IR state at the same time work at VIR and/or IrCOMM state. You can use the printer only after reset if the printer isn't work in the state you need to be. Method of setting IR model please look at 3.3 printer setting.

Original IR can work at Baud Rate of 9600bps、19200bps、38400bps、57600bps、115200bps.

When printing in original IR (RAW-IR) and IrDA (IrCOMM) mode, please align master's infrared line to printer's infrared windows in printing process. The distance can't exceed 50 cm (may be different by the master device). The angle can't exceed 30 degrees.

Details of original IR and IrCOMM develop please refer to <development manual of portable mini-printer>. Demand the manual from your supplier.

3.3.3 Bluetooth pairing and print

P200 portable mini-printer pair with master of driver before work .Pair process initiate by master.

Usual pairing as follow:

- 1、 Turn on the printer
- 2、 Master search external Bluetooth
- 3、 Select the SPB printer if there has several external Bluetooth device.
- 4、 Bring in password “0000”
- 5、 Finished pairing.

Please look at the master Bluetooth function description about specific pairing method.

The printer must be power on in pairing.

Notice: Don’ t turn on many printers at the same time when pairing. Or can’ t determine which printer has paired success.

After pairing successful, other PC can still be paired with the printer. Each printer can pair with 8 PC machine. If pairing more PC, the PC paired with printer earliest will be delete automatically. At the same time, if PC need drive printer to print, need to re-pair.

Using Bluetooth interface to print

For PC with a virtual Bluetooth serial port (such as mobile phone of SMARTPHONE, POCKET PC, PALM, notebook computers), can send print data to P200 printer to print through virtual Bluetooth serial port after pairing successful. If the PC don’ t have virtual Bluetooth serial port or need drive P200 mini-printer to print, please contact the PC supplier.

3.4 Light and buzzer signal instruction

Printer has one buzzer and four indicator lights to prompts user of printer’s status. Indicator lights are used to represent the current status of printer. Buzzer used to indicate changes of printer’s status. Four indicator lights are low paper indicator, system light, charge indicator and Bluetooth connection indicator.

Feed indicator	Power indicator	Printer status	Buzzer
Quick flashing	extinguish	charging	
Slow flashing	Extinguish	Low battery	
Long bright	Extinguish	Charging end	
None	Long bright	Power on status	
Slow flashing	Slow flashing	Out of paper	Chirping sound
none	Slow flashing	Dormancy status	

四 Other information

4.1 Printer development manual

《development manual of portable mini-printer》 is a technical manual for developer to develop printer application, which can be obtained from your supplier. This manual contains technical description of hardware interface(serial communication interface, IR interface) of printer, technical document of print control instruction set and others such as how to print black label, how to use black label to locate.

4.2 Pre-printed black mark instruction

Please comply with the following when user use pre-printed black label to locate notes or print black label. Or it may lead printer can't recognize the black label.

Pre-printed black mark specifications:

Printing position: Black mark should be printed on the left edge of text face.

Width range : $\text{width} \geq 7\text{mm}$

Height range: $4\text{mm} \leq \text{height} \leq 6\text{mm}$

Reflectivity of IR light: $< 10\%$ (other parts of paper width of the black mark for reflectivity of IR light $> 65\%$)

Hps: Hps is distance between black mark's lower edge of printer with starting edge of the print.

$0\text{mm} \leq \text{Hps} \leq 1\text{mm}$