



# JB-70 Dental X-Ray System



## Installation and Service Manual

REF. KIT #30-A2048

00-02-1569 Rev T

REV. T

ECN: P2446

**Attention:**

The equipment must only be installed and operated in accordance with the safety procedures and operating instructions given in this manual and in the User Manual for the purposes and applications for which it was designed. Modifications and/or additions to the equipment may only be carried out by Progeny – A Midmark Company or by third parties expressly authorized to do so. Such changes must comply with legal requirements as well as with the generally accepted technical rules. It is the responsibility of the user to ensure that existing legal regulations regarding installation of the equipment with respect to the building are observed.

**X-RAY PROTECTION:**

X-ray equipment may cause injury if used improperly.

**The instructions contained in this manual must be read and followed when operating the JB-70. Your dealer will assist you in placing the JB-70 in operation.**

The JB-70 Dental X-Ray System provides a high degree of protection from unnecessary x-radiation. However, no practical design can provide complete protection nor prevent operators from exposing themselves or others to unnecessary radiation.



**More Than Imaging. Excellence.**

**Midmark Corporation**

675 Heathrow Drive  
Lincolnshire, Illinois 60069 U.S.A.  
Phone: (888) 924-3800 Fax: (847) 415-9801  
[progenydenal.com](http://progenydenal.com)



# **JB-70 Dental X-Ray System**

## **Installation and Service Manual**

**00-02-1569 Rev T**

**ECN: P2446**

### **Midmark Corporation**

675 Heathrow Drive  
Lincolnshire, Illinois 60069 U.S.A.  
Phone: (888) 924-3800 Fax: (847) 415-9801  
[progenydenal.com](http://progenydenal.com)

© Progeny Dental 2003, U.S. Patents D470237 and D469182

## Table of Contents

|   |    |
|---|----|
| General Information .....   | 3  |
| Indications for Use.....  | 3  |
| Contraindications.....  | 3  |
| Warnings/Precautions.....   | 3  |
| CAUTIONS.....   | 4  |
| Product Description.....  | 5  |
| Reach and Coverage.....   | 7  |
| Environmental Factors.....  | 12 |
| Support Requirements.....   | 12 |
| Electrical Requirements.....  | 13 |
| Compliance with Applicable Standards.....                           | 13 |
| Certified Components.....   | 14 |
| EC Declaration of Conformity .....                                  | 15 |
| Authorized Representatives.....                                     | 16 |
| Explanation of Symbols on Technical Labels .....                    | 17 |
| Obtaining Technical Support .....                                   | 17 |
| Installation Options .....  | 18 |
| Mounting Configurations.....  | 18 |
| Installation Options .....  | 19 |
| Mounting Configurations.....  | 19 |
| Operator Panel Locations .....                                      | 21 |
| Operator Panel Locations .....                                      | 23 |
| Installation Procedures.....  | 24 |
| Preparing to Install the JB-70 .....                                | 24 |
| Installing the Control Unit on a Single Wood Stud Wall .....        | 26 |
| Installing the Control Unit on a Dual Wood Stud Wall.....           | 31 |
| Installing the Control Unit on a Metal Stud Wall.....               | 33 |
| Installing the Horizontal Arm and Brake Assembly .....              | 35 |
| Installing the Articulating Arm and Tubehead Assembly.....          | 37 |
| Connecting the Cables .....   | 39 |
| Electrical Verification .....                                       | 41 |
| Mechanical Adjustments.....   | 43 |
| Installing the Control Unit Front Cover and the Operator Panel..... | 44 |
| Installing Plastic Covers.....                                      | 46 |
| Checking System Functions.....                                      | 47 |
| System Function Checklist .....                                     | 48 |
| Optional Installation Procedures .....                              | 49 |
| Installing the Coil-cord Hand Switch Option (30-A2040).....         | 50 |
| Installing the 12 inch Cone (30-A2033).....                         | 52 |
| Installing the Progeny Remote Exposure Switch (30-08101).....       | 53 |
| Troubleshooting .....   | 54 |
| Performance Issues.....   | 54 |
| Checking System Power.....  | 54 |
| Adjusting the Line Voltage Compensation Circuit.....                | 54 |

---

|   |    |
|---|----|
| Operator Panel Test .....                         | 56 |
| Power Board Tests .....                           | 57 |
| Logic Board Tests.....                            | 58 |
| Obtaining Technical Support .....                 | 66 |
| Setting Operator Panel Controls .....             | 71 |
| Power On Settings.....                            | 71 |
| Pre-programmed Exposure Times.....                | 71 |
| Changing Programmed Exposure Times.....           | 73 |
| Replacement Parts .....                           | 74 |
| Arm and Tubehead .....                            | 74 |
| Horizontal Arm .....                              | 75 |
| Mounting Plates .....                             | 76 |
| Operator Panel .....                              | 76 |
| Control Unit.....                                 | 77 |
| Hand Switch .....                                 | 78 |
| Specifications.....                               | 79 |
| JB-70 Dental X-Ray System .....                   | 79 |
| Appendix A .....                                  | 82 |
| Assembly Instructions for JB-70 Mobile Unit ..... | 82 |

## General Information

**Indications for Use** The JB-70 Intraoral Dental X-Ray System is to be used as an extraoral source of x-rays in dental radiography.

**Contraindications:** None Known

### Warnings/Precautions

|                          |  |
|--------------------------|--|
| <b>Radiation Safety</b>  | <p>Only qualified and authorized personnel may operate this equipment observing all laws and regulations concerning radiation protection.</p> <ul style="list-style-type: none"> <li>• The operator at all times must remain 6ft. (2m) from the focal spot and the X-ray beam for operator protection.</li> <li>• Full use must be made of all radiation safety features on the equipment.</li> <li>• Full use must be made of all radiation protection devices, accessories and procedures available to protect the patient and operator from x-ray radiation.</li> </ul>   |
| <b>Electrical Safety</b> | <ul style="list-style-type: none"> <li>• Only qualified and authorized service personnel should remove covers on the equipment.</li> <li>• This equipment must only be used in rooms or areas that comply with all applicable laws and recommendations concerning electrical safety in rooms used for medical purposes, e.g., IEC, US National Electrical code, or VDE standards concerning provisions of an additional protective earth (ground) terminal for power supply connection.</li> <li>• Before cleaning or disinfecting, this equipment must always be disconnected from the main electrical supply.</li> <li>• The JB-70 Dental X-Ray System is ordinary type medical equipment without protection against ingress of liquids. To protect against short-circuit and corrosion, no water or any other liquid should be allowed to leak inside the equipment.</li> </ul> |
| <b>Explosion Safety</b>  | <p>This equipment must not be used in the presence of flammable or potentially explosive gases or vapors, which could ignite, causing personal injury and/or damage to the equipment. If such disinfectants are used, the vapor must be allowed to disperse before using the equipment.</p>  |

## CAUTIONS

When using lag screws as the method of attachment. It is imperative to consider the full scope of the task. Several factors must be considered for safe, permanent installations. Some of the key issues are:

- Lumber commonly used in construction projects can be different from location to location.
- The grade, age, position, and overall condition can vary greatly.
- The attachment stud may have additional, hidden loads.
- The location of the pilot hole with respect to the center of the stud will affect the load bearing ability.
- The size of the pilot hole required for the lag screw will be different based on the grade, age and condition of the lumber.
- **Never over-tighten the lag screw as this will weaken the mechanical connection.**
- Lumber with splits or cracks should not be used for attachment.
- **Plywood, particle board or similar construction materials, should not be used for attachment.**
- Consider lumber dryness or moisture when attaching to exterior framing studs.
- Progeny mechanical designs will exert up to 850 pounds (386 kilograms) of loading on the supporting structure.
- Progeny provides fasteners for average installations. Based on specific installation conditions, it may be necessary to choose a alternate fastener or fastening methods.
- Seek the advice of a professional structural engineer to clarify any issues before the installation.
- Inspect the attachment method 30 days after the installation and, every 6 months thereafter.
- Lag screws are not intended to be used as an attachment method for metal supports such as those found in center island pass-through cabinets. Progeny provides machine screws, large flat washers and nylock nuts to use when fastening the system to metal supports.

### Your responsibilities as an installer and service engineer

**Verification of machine performance after installation** must be performed according to the guidelines identified in the “System Function Checklist” which may be found in the User Manual or, the Installation and Service Manual.

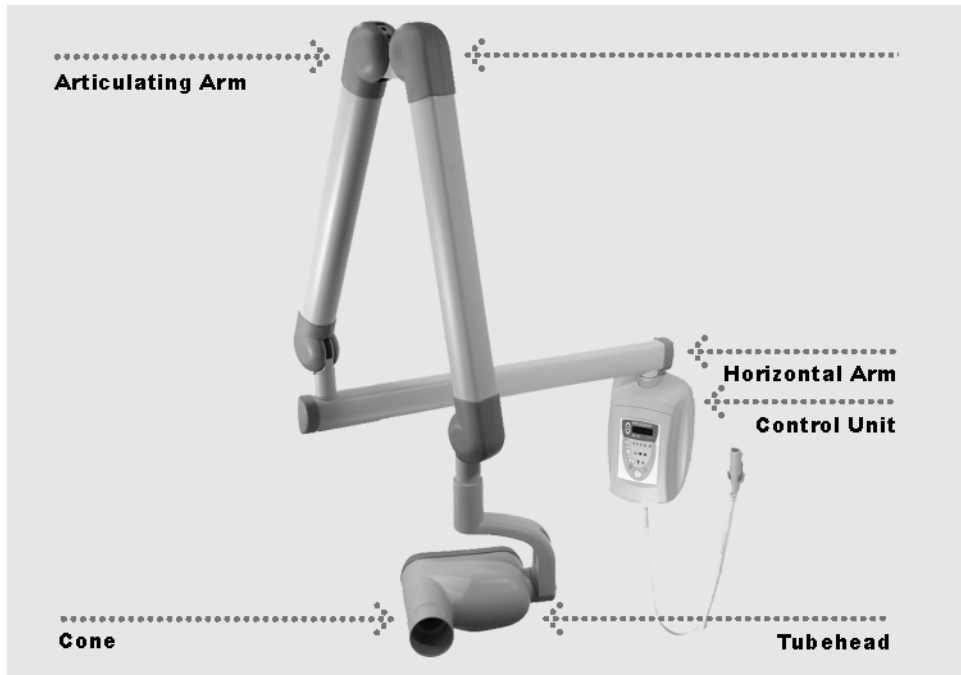
**Verification of machine performance after maintenance or repair** must be performed according to the guidelines identified in the “System Function Checklist” and the “Adjusting the Line Voltage Compensation Circuit” instructions which may be found in the Installation and Service Manual.



## Product Description

|                                 |  |
|---------------------------------|--|
|                                 | <p>The JB-70 Dental X-Ray System is a state-of-the-art intra-oral x-ray machine. The JB-70 consists of five components, as shown in Figure 1: the Control Unit, the Tubehead, the Articulating Arm, the Horizontal Arm and the Cone.</p>   |
| <b>Control Unit</b>             | <p>The Control Unit provides for the input power connection and control of the Tubehead and Operator Panel. It provides automatic line voltage compensation, kVp control and exposure time control. The Control Unit consists of the mounting base and Operator Panel.</p>   |
| <b>Tubehead</b>                 | <p>The Tubehead contains the x-ray tube, high voltage transformer, and Cone. The Tubehead is shipped already assembled to the Articulating Arm.</p> <p><b>Note:</b> There is a small hole in the plastic handle covering the back of the Tubehead. Under no circumstances should this hole be blocked as it provides an air vent to allow the Tubehead oil to expand and contract as the unit is operated.</p> |
| <b>Articulating Arm</b>         | <p>The Articulating Arm provides the articulation support for the Tubehead and the reach and coverage of the Tubehead to the patient. The Articulating Arm allows smooth movement for precise positioning and does not drift or vibrate when left in position.</p>   |
| <b>Horizontal Arm</b>           | <p>The Horizontal Arm helps provide the necessary reach for the JB-70. The Horizontal Arm pivots smoothly around a shaft inserted in the top of the Control Unit. The Horizontal Arm contains an access cover to connect the cable from the Horizontal Arm to the Control Unit. The Horizontal Arm is available in three lengths, providing reaches of 56, 66 and 76 inches.</p>                               |
| <b>Cone</b>                     | <p>The Cone establishes the distance from the x-ray tube to the patient's skin. It provides positioning assistance and collimates the x-ray beam to within a defined circle at its end. The JB-70 is shipped with the standard 8 inch Cone attached to the Tubehead. A 12 inch Cone (30-A2033) can be ordered as an option. Eight and 12" rectangular cones available.</p>                                     |
| <b>Installation and Service</b> | <p>The JB-70 Dental X-Ray System should only be installed and serviced by approved dealer personnel. Contact Progeny – A Midmark Company at (888) 924-3800 if you need assistance locating an approved dealer.</p>   |

Figure 1  
Component  
Diagram



## Reach and Coverage

### Horizontal Arm Lengths

The reach of the system is measured from the tip of the Cone with the arm fully extended and the Cone pointing back toward the pivot of the wall plate. This measurement method accommodates the normal positioning of the Tubehead to the patient. A patient can, therefore, be positioned without difficulty with the chair located within a radius outward from the pivot point to the dimensions shown in the diagrams.

The JB-70 Horizontal Arm is available in three lengths. Each length gives the system a different reach. Catalog I7015 with a 30-A2038 Horizontal Arm has a reach of 56 inches. Catalog I7016 with a 30-A2034 Horizontal Arm has a reach of 66 inches. Catalog I7017 with a 30-A2025 Horizontal Arm has a reach of 76 inches. The diagrams show Catalog I7017 with a 76 inch reach. For Catalog I7016 with a 66 inch reach, reduce the dimensions by 10 inches. For Catalog I7015, reduce the dimensions by 20 inches.

### Optional 12 inch Cone

The 76 inch reach for Catalog I7017 assumes the use of the 8 inch Cone that is supplied with the system. If the optional 12 inch Cone (30-A2033) is used, the reach is reduced by 4 inches.

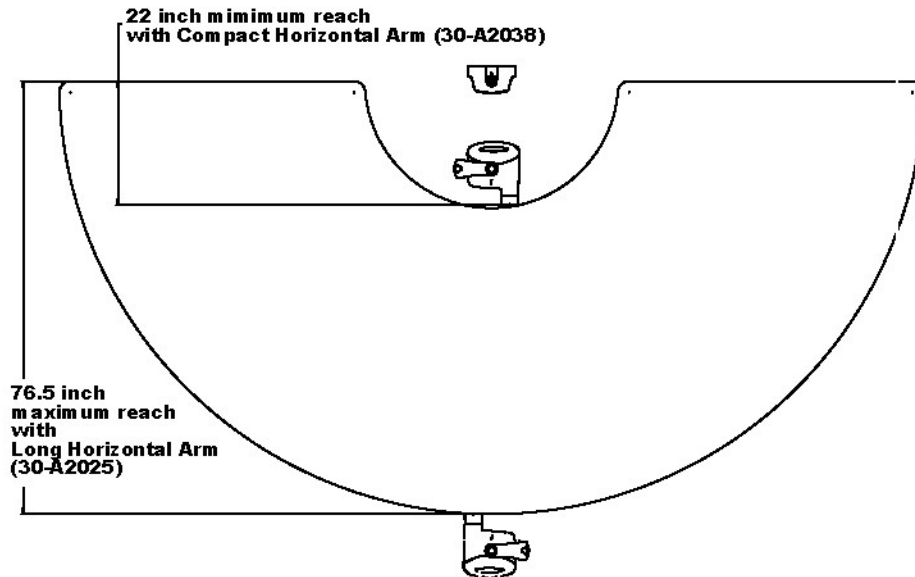


Figure 2  
Reach and Coverage Diagram

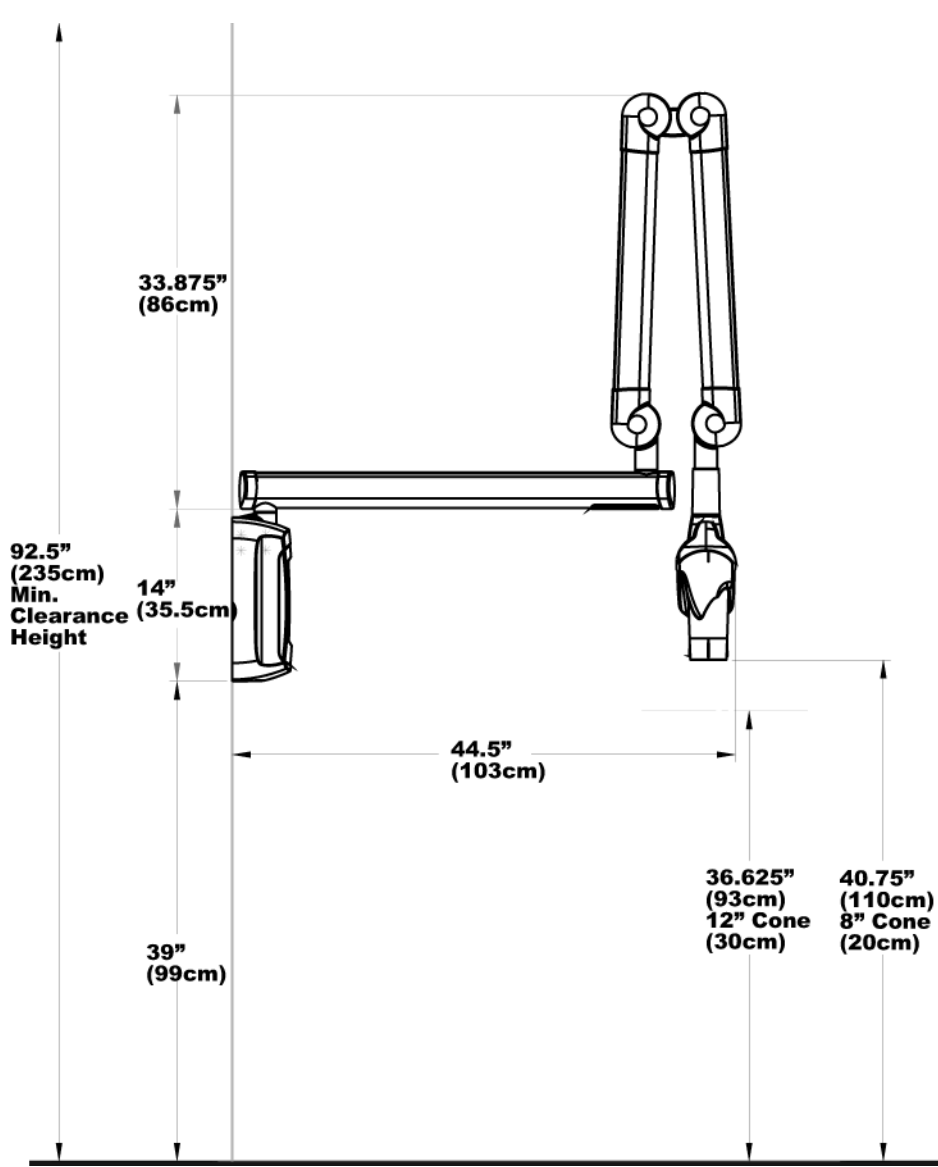


Figure 3  
Cabinet  
Mounting  
Dimensions

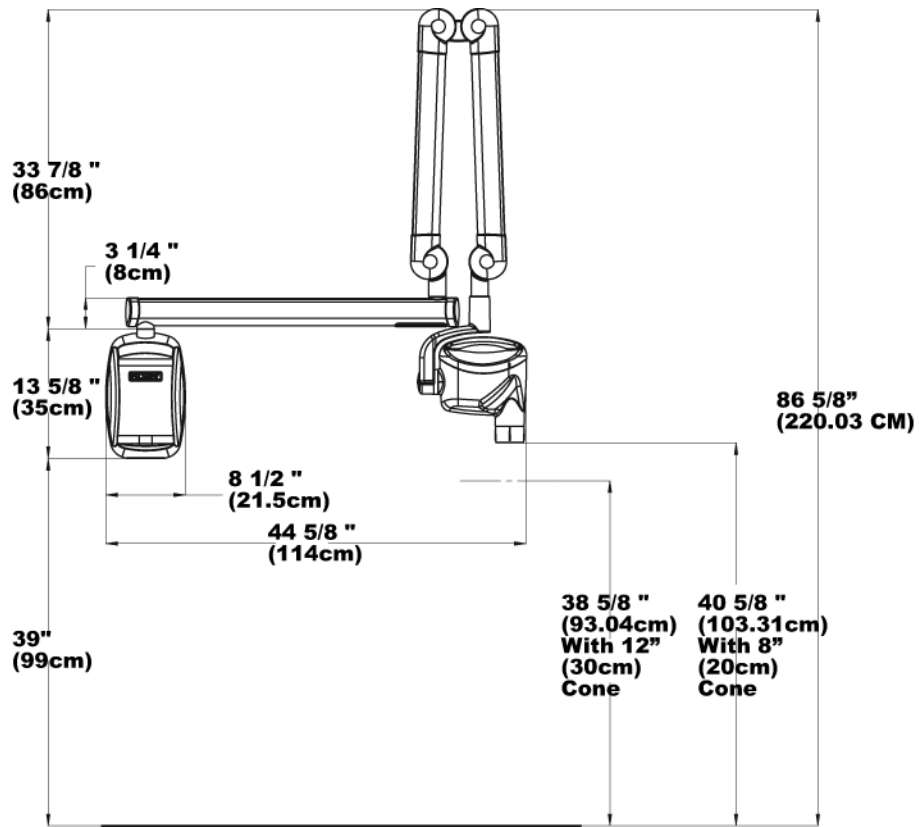


Figure 4  
Retracted Wall Mount

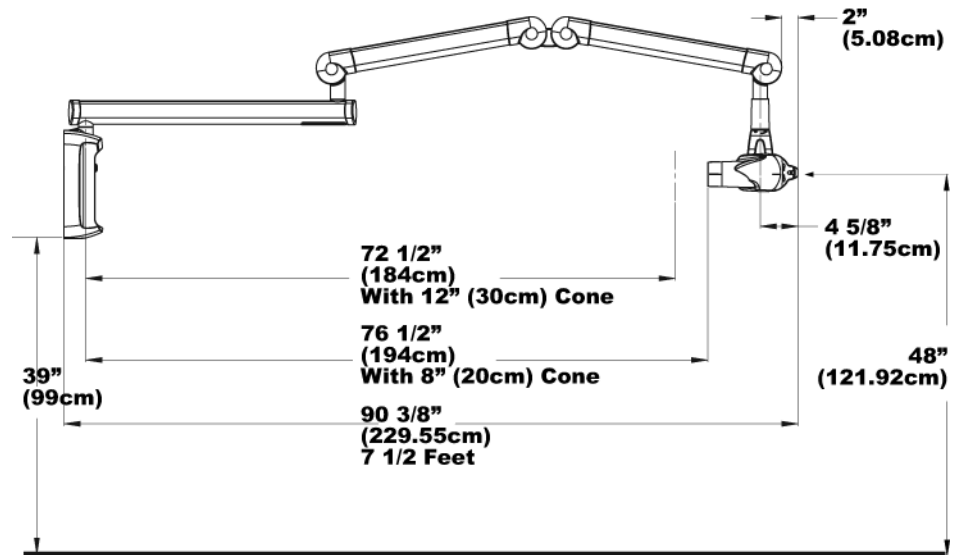


Figure 5  
Extended  
Position Wall or  
Cabinet Mount

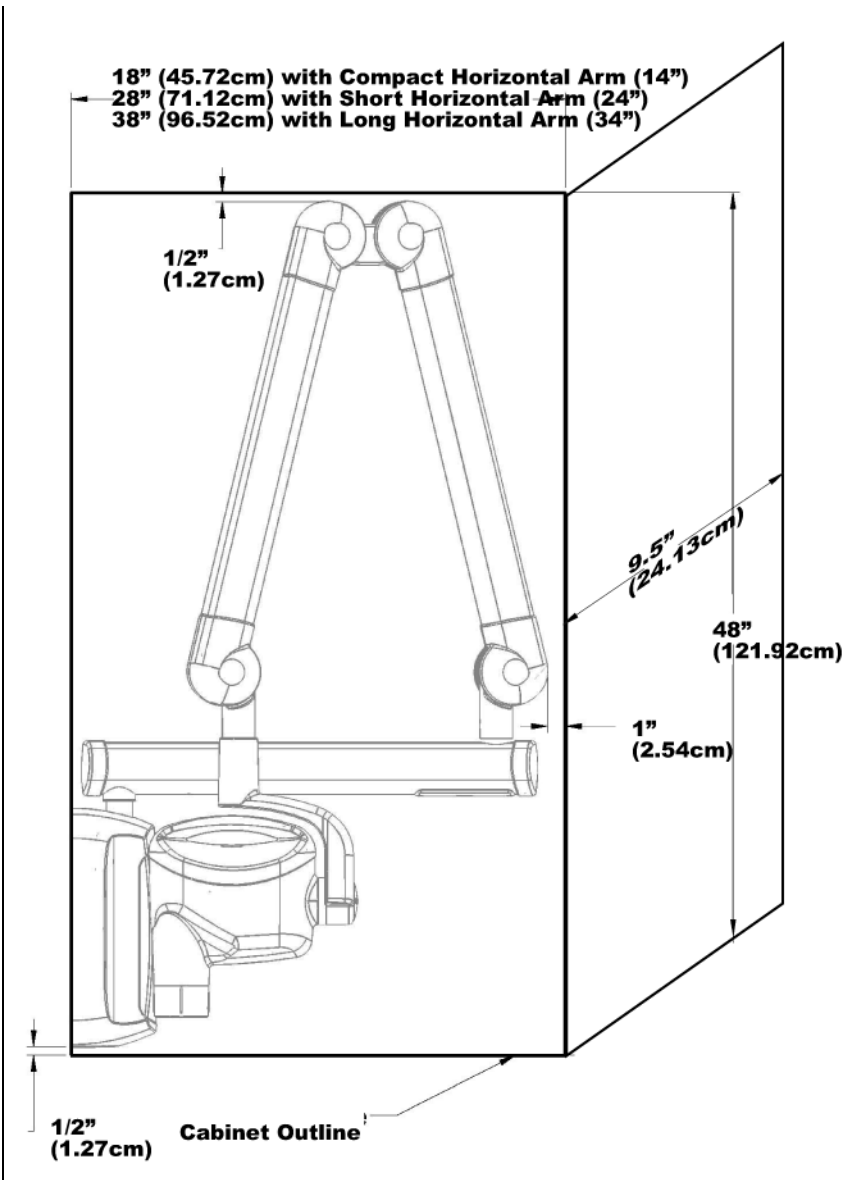


Figure 6  
Retracted  
Position for a  
Cabinet Mount

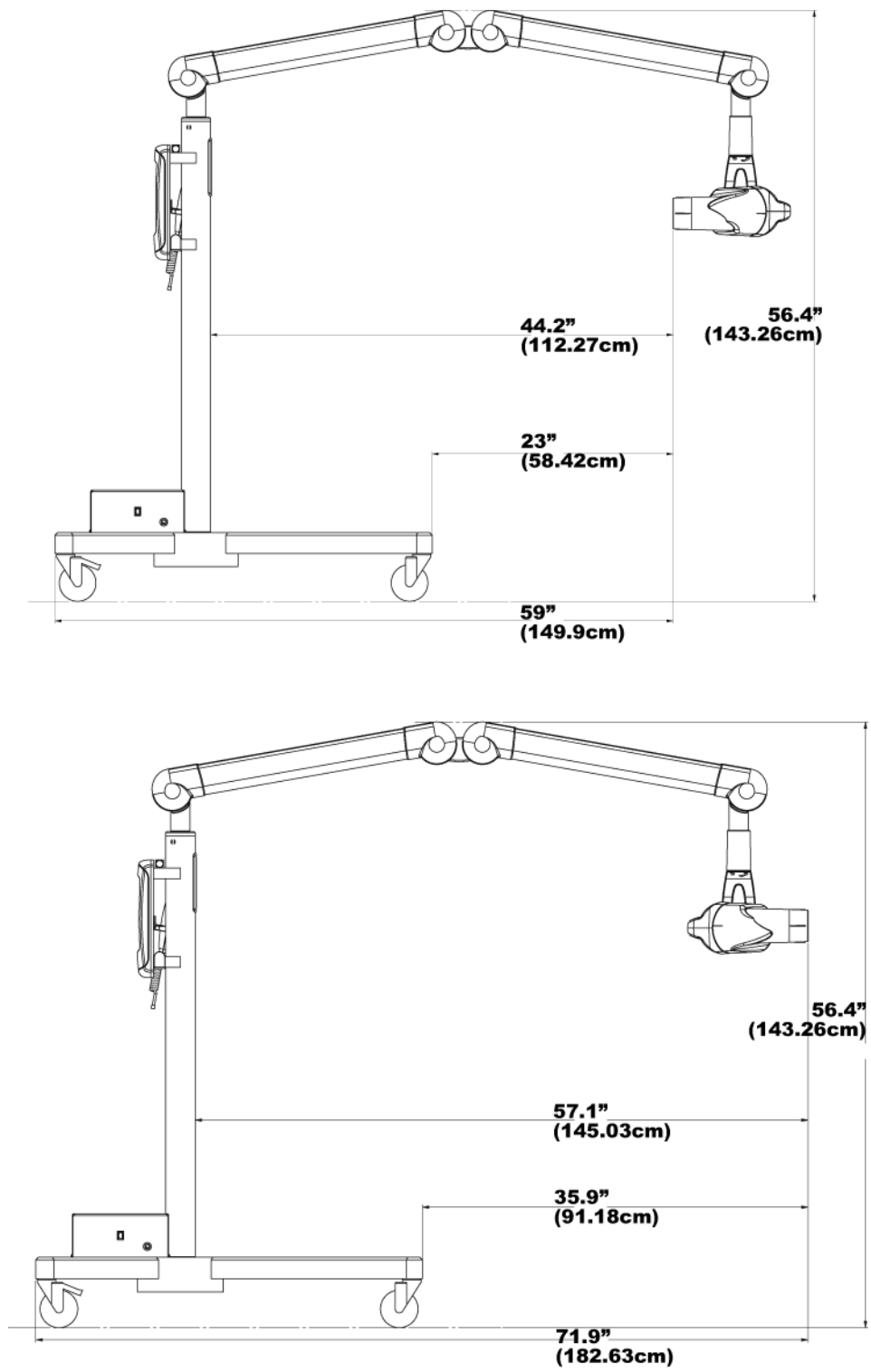


Figure 7  
Extended  
Position

## Environmental Factors

**Use**

The JB-70 Dental X-Ray System is intended for indoor use for normal dental applications at temperatures in the range +50 F/+113 F (+10 / + 45 C) and at a maximum altitude of 12,000 feet. Humidity should not cause condensation to form on the unit.

**Storage**

Storage temperature should not exceed the range -31 F / + 150 F (-35 C / + 66 C).

## Support Requirements

The JB-70 Dental X-Ray System is designed to mount on a single wood 2x4 inch drywall stud or equivalent wall support. It can also be mounted on concrete or other similar wall construction, mounting to a plywood or particle board wall is not acceptable. Verifying the wall support capability and the selection of the proper mounting hardware is the responsibility of the installer.

Please note that a two stud wall plate assembly (30-A2042) is available as an option to mount on two wooden studs. (30-A2043) is available as a metal stud mounting kit.

The wall support and mounting hardware for the JB-70 must withstand a 100 lb. (45.36 kg) shear load, and a 400 lb. (182 kg) withdrawal force at each of the mounting bolts. The wall fabrication and attachments to the building structure must be capable of withstanding a load moment of 850 ft. lbs. (118 kg.m.).



## Electrical Requirements

| <b>Main Power Supply</b>   | The JB-70 Dental X-Ray System requires a three-wire electrician-supplied power supply. Two power lines, (L) Line and (N) Neutral, and a Ground are required. It is recommended that the unit be installed with a dedicated electrical line connected to a breaker with a minimum 15 amp rating. The wiring must provide for a permanently grounded power line configuration. |                 |                 |         |         |         |         |  |
|----------------------------|--|-----------------|-----------------|---------|---------|---------|---------|--|
| <b>Line Cord Use</b>       | The installer must determine the suitability of installing the JB-70 with a line cord. If a line cord is used, the installer must ensure that the unit is properly grounded and has the required line rating.  |                 |                 |         |         |         |         |  |
| <b>Line Voltage</b>        | Nominal 120 VAC +/- 10%,      Nominal 230 VAC +/- 10%  |                 |                 |         |         |         |         |  |
| <b>Fuse Rating</b>         | 10A    250V    UL Recognized   |                 |                 |         |         |         |         |  |
| <b>Max Line Resistance</b> | <table border="1"> <tr> <th>Nominal Voltage</th> <th>Line Resistance</th> </tr> <tr> <td>120 VAC</td> <td>0.4 ohm</td> </tr> <tr> <td>230 VAC</td> <td>1.0 ohm</td> </tr> </table>   | Nominal Voltage | Line Resistance | 120 VAC | 0.4 ohm | 230 VAC | 1.0 ohm |  |
| Nominal Voltage            | Line Resistance  |                 |                 |         |         |         |         |  |
| 120 VAC                    | 0.4 ohm  |                 |                 |         |         |         |         |  |
| 230 VAC                    | 1.0 ohm  |                 |                 |         |         |         |         |  |

## Compliance with Applicable Standards

|                                       |   |
|---------------------------------------|---|
| <b>Radiation Protection</b>           | <p>The certified components of the JB-70 Dental X-Ray System comply with Radiation Performance Standards 21 CFR, Subchapter J, at the time of manufacture.</p> <p>The certified components of the JB-70 Dental X-Ray System comply with IEC 60601-1-3 Radiation protection/x-ray equipment.</p> |
| <b>UL 2601-1 File Number: E181750</b> | Classified by Underwriters Laboratories Inc. with respect to electrical shock, fire and mechanical hazards only in accordance with UL 60601-1, and CAN/CSA C22.2 NO, 601.1-M90, and to the following particular standards, IEC60601-2-7, IEC60601-2-28 and IEC60601-2-32.                       |
| <b>EMI/EMC</b>                        | IEC60601-1-2  |

## Certified Components

### 120V System

| Component              | Reference Number |
|------------------------|------------------|
| Tubehead, Blue         | 30-A1005         |
| Tubehead, Gray         | 30-A1011         |
| Control Unit           | 30-A0001         |
| Cone 8 inch            | 30-A2016         |
| Cone 12 inch           | 30-A2033         |
| Cone 8 in. Rectangular | 30-A2041         |
| Cone 60mm              | 30-A2101         |
| Cone 59mm              | 30-A2107         |
| Cone 36mm x 46mm       | 30-A2112         |

### 230V System

| Component              | Reference Number |
|------------------------|------------------|
| Tubehead, Blue         | 30-A1007         |
| Tubehead, Gray         | 30-A1016         |
| Control Unit           | 30-A0003         |
| Cone 8 inch            | 30-A2016         |
| Cone 12 inch           | 30-A2033         |
| Cone 8 in. Rectangular | 30-A2041         |
| Cone 60mm              | 30-A2101         |
| Cone 59mm              | 30-A2107         |
| Cone 36mm x 46mm       | 30-A2112         |

## EC Declaration of Conformity

| Name and Description of Product | Progeny JB-70  |
|---------------------------------|--|
|                                 | Catalog Model I7017, 76 inch reach, 120Volt (Gray unit I7017G)<br>30-A0001, Control, 120Volt<br>30-A2025, Extension Arm, Long  |
|                                 | Catalog Model I7016, 66 inch reach, 120Volt (Gray I7016G)<br>30-A0001, Control, 120Volt<br>30-A2034, Extension Arm, Short  |
|                                 | Catalog Model I7015, 56 inch reach, 120Volt (Gray I7015G)<br>30-A0001, Control 120Volt<br>30-A2038, Extension Arm, Compact   |
|                                 | Catalog Model I7027, 76 inch reach, 230Volt (Gray I7027G)<br>30-A0003, Control, 230Volt<br>30-A2025, Extension Arm, Long   |
|                                 | Catalog Model I7026, 66 inch reach, 230Volt (Gray I7026G)<br>30-A0003, Control, 230Volt<br>30-A2034, Extension Arm, Short  |
|                                 | Catalog Model I7025, 56 inch reach, 230Volt (Gray I7025G)<br>30-A0003, Control, 230Volt<br>30-A2038, Extension Arm, Compact  |
|                                 | Class: IIb<br><br>The following regulatory documents apply:<br>UL 60601-1<br>IEC 60601-1-2<br>IEC 60601-1-3<br>IEC 60601-2-7<br>IEC 60601-2-28<br>IEC 60601-2-32<br>Medical Device directive<br>ISO 13485: 2003<br>FDA 510K File Number K020070  |
| <b>Declaration</b>              | Midmark Corporation declares that the products described herein meet all the applicable Essential Requirements of the EC Medical Device Directive 93/42/EEC in Annex I. For Class IIb products described herein, the product is manufactured, inspected, tested and released in accordance with the approved quality assurance system established in accordance with ISO 13485 and Annex II of the EC Medical Device Directive under the Supervision of the SGS United Kingdom Ltd. a Notified Body. |
| <b>Contact</b>                  | Technical Support<br><a href="mailto:techsupport@progenydenal.com">techsupport@progenydenal.com</a>  |

## Authorized Representatives







### North America

Midmark Corporation  
675 Heathrow Dr.  
Lincolnshire, IL 60069  
Phone: 888-924-3800  
Fax: 847-415-9801

### Europe

CE Partner 4U  
Esdoornlaah 13  
3951DB Maarn  
The Netherlands  
Phone: +31.343.442.524  
Fax: +31.343.442.162

## Explanation of Symbols on Technical Labels

|   |   |
|---|---|
|    | Type B: Protection against electric shock (IEC 60601.1-1)   |
|    | Consult written instructions in User's Manual.  |
|    | ATTENTION RAYONS-X:<br>OPERATION SEULEMENT PAR DU PERSONNEL AUTORISE. VOIR MANUEL DE L'OPERATEUR.   |
|    | WARNING X-RAY<br>THIS X-RAY UNIT MAY BE DANGEROUS TO PATIENT AND OPERATOR UNLESS SAFE EXPOSURE FACTORS AND OPERATING INSTRUCTIONS ARE OBSERVED. |
|    | <i>X-RAY EMISSION</i>   |
| <b>L</b>  | Mains HOT WIRE  |
| <b>N</b>  | Mains NEUTRAL WIRE  |
|  | Earth Ground  |

## Obtaining Technical Support

|                |   |
|----------------|---|
| <b>Contact</b> | Midmark Corporation<br>675 Heathrow Dr.<br>Lincolnshire, IL 60069<br>Phone: 888-924-3800<br>Fax: 847-415-9801 |
|----------------|---|

# Installation Options

## Mounting Configurations

### Mounting Template

This section gives instructions for installing the JB-70 Dental X-Ray System in three mounting configurations. Use the mounting template, shown in Figure 8, to guide single stud installations. Reverse the template for dual-stud installations.

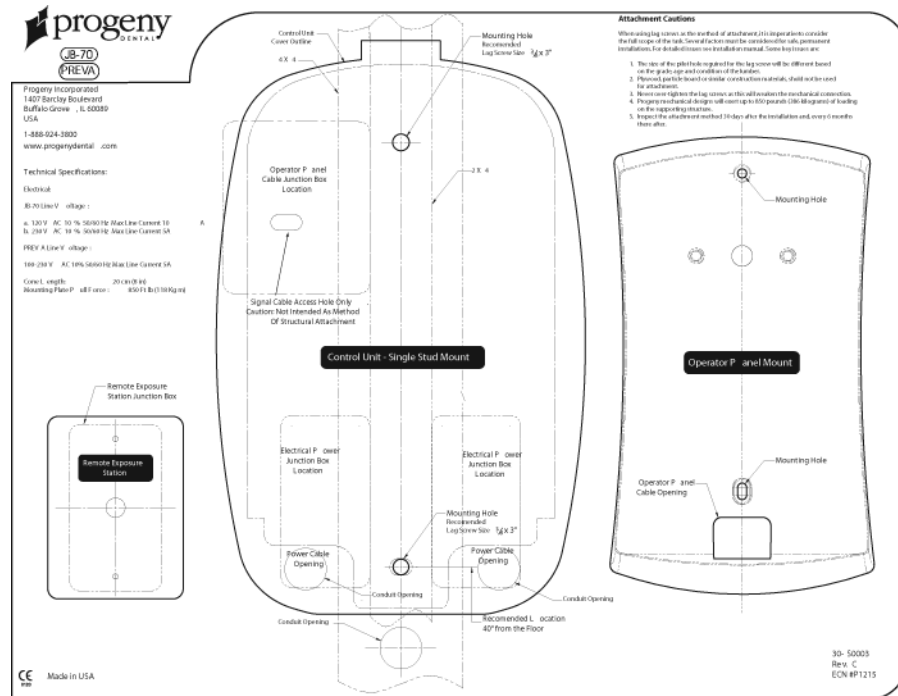


Figure 8  
Mounting Template

**CAUTION:**  
Lag screws are not intended to be used as an attachment method for metal supports such as those found in center island pass-through cabinets. Midmark provides machine screws, large flat washers and nylock nuts to use when fastening the system to metal supports.

## Installation Options

### Mounting Configurations

#### Single Wood Stud Wall, Solid Wall or Reinforced Wood Cabinet

The Control Unit should be located at a height of 39 inches (99 cm) from the floor to the bottom of the control. The large range of travel of the Articulating Arm provides some flexibility in the vertical position. Two mounting holes are provided. Refer to the supplied mounting template for specific locations.

When installing in a reinforced wood cabinet, refer to the manufacturer of the pass-through box or cabinet for proper mounting configuration and height. Refer to the supplied mounting template for specific locations of power supply and/or Operator Panel cable access points.

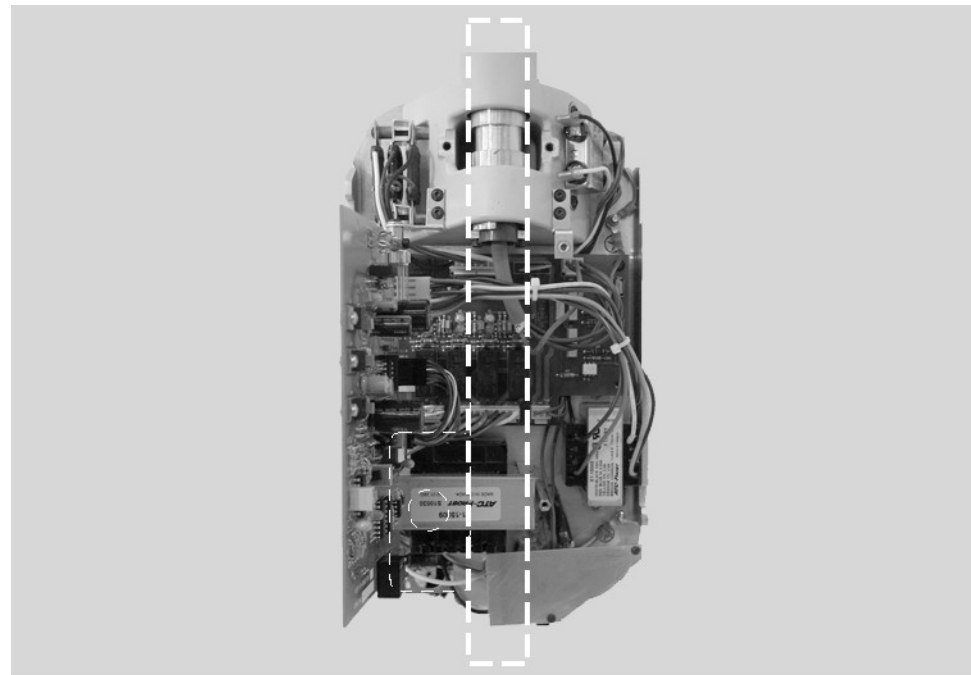
**CAUTION:**

**Lag screws are not intended to be used as an attachment method for metal supports such as those found in center island pass-through cabinets. Progeny provides machine screws, large flat washers and nylock nuts to use when fastening the system to metal supports.**

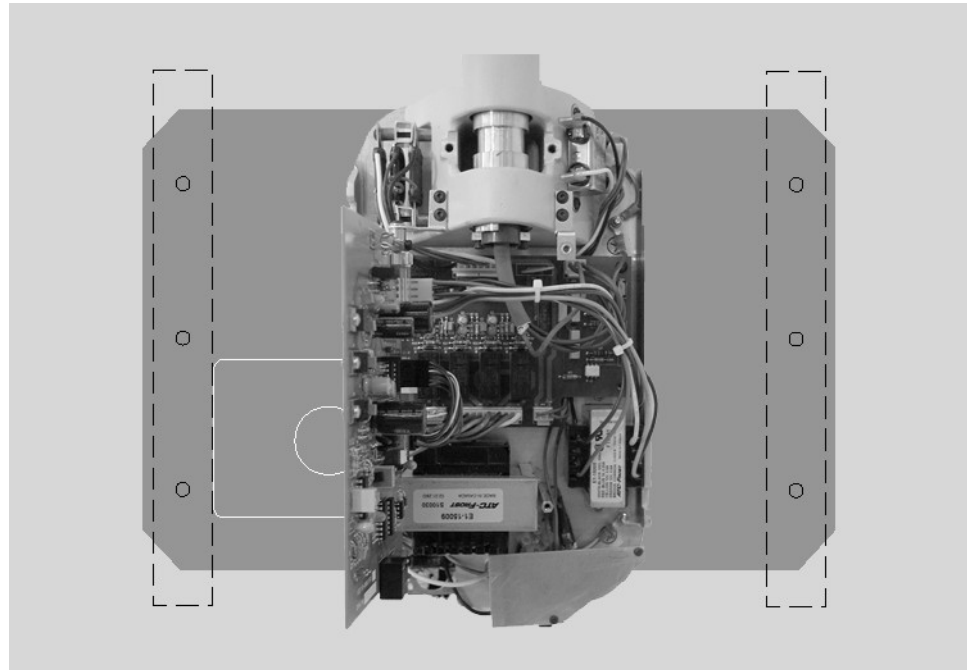
In order to mount to a solid, masonry type wall, the same mounting holes and mounting template as the single wood wall stud are used. The installer must supply appropriate fasteners.

The power supply 2x4 junction box should be mounted to the left of the mounting stud at the appropriate height, as shown in Figure 9.

**Note:** A 4x4 junction box will not be covered by the Control Unit. Refer to the supplied mounting template for specific location.



**Figure 9**  
**Wood Wall Stud**  
**Mount**



**Figure 10**  
**Dual Wood Stud**  
**Mount**

### **Dual Wood Stud** **Wall**

When installing the JB-70 Dental X-Ray System on two 16-inch centered wood studs, the Control Unit mounts to a wall plate (Two Stud Mounting Kit 30-A2042, purchased as an option), which mounts to the wood studs, as shown in Figure 10. Fasteners are provided with the wall plate.

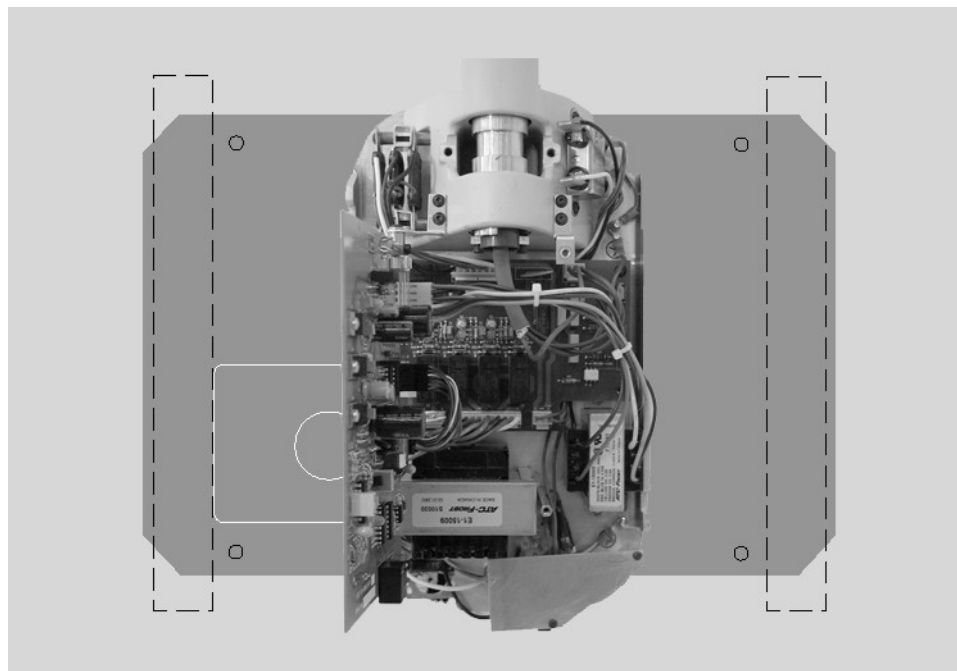
In mounting configurations using the dual stud wall plate, there are several holes available for incoming line power. This is to provide for various locations of existing power boxes when installing as a replacement unit. Refer to the reverse side of the mounting template, Figure 8, for hole locations.



## Metal Stud Wall

When installing the JB-70 Dental X-Ray System on a metal stud wall, the Control Unit mounts to a wall plate (Two Stud Mounting Kit 30-A2042, purchased as an option) and uses an additional support plate (Metal Stud Support Plate Kit 30-A2043, purchased as an option) positioned on the back end of the wall. Fasteners are provided with the wall plate and support plate. The wall fabrication and attachments to the building structure must be capable of withstanding a load moment of 850 ft. lbs. (118 kg.m.). If the wall on which the JB-70 is to be installed does not meet this requirement, it must be reinforced.

In mounting configurations using the dual stud wall plate, there are several holes available for incoming line power. This is to provide for various locations of existing power boxes when installing as a replacement unit. Refer to the mounting template for hole locations.



**Figure 11**  
**Metal Stud Mount**

## Operator Panel Locations

### On Control Unit

The Operator Panel for the JB-70 Dental X-Ray System can be installed on the Control Unit or mounted remotely on a wall.

The Operator Panel snaps on to the front of the Control Unit. Installation of the Operator Panel on the Control Unit may require the purchase and use of the coil-cord hand switch option, 30-A2040.

### Remote Operator Panel

The Operator Panel is mounted on the wall remote from the Control Unit.

If the Operator Panel is mounted separate from the Control Unit, a supplied cable must be run from the Control Panel to the Operator Panel. Where local codes require, a separate 2x4 junction box should be mounted to the left of the mounting stud above the power supply box. Refer to the supplied mounting template for specific location.

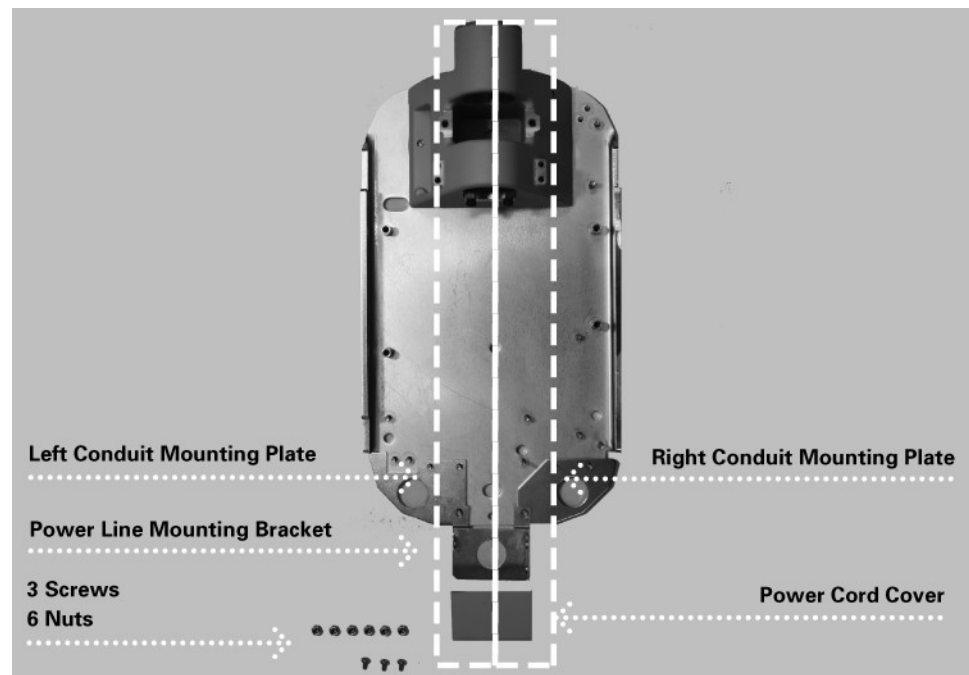
## Installing the 4x4 Mount

### Instructions

The 4x4 Mount kit (30-A2099), shown in Figure , contains the items below:

- Power line bracket
- Power cord cover
- Left conduit mounting plate
- Right conduit mounting plate
- 3 Phillips screws
- 6 nuts

1. Using the three Phillips screws, secure the power line bracket to the power line cord cover.
2. Place the right and left conduit mounting plates on the control.
3. Place the assembled power line bracket and cord cover on the two bottom-most threaded studs.



**Figure 12**  
4x4 Mount Cabinet  
Layout

## Operator Panel Locations

### On Control Unit

The Operator Panel for the JB-70 Dental X-Ray System can be installed on the Control Unit or mounted remotely on a wall.

The Operator Panel snaps on to the front of the Control Unit. Installation of the Operator Panel on the Control Unit may require the purchase and use of the coil-cord hand switch option, 30-A2040.

### Remote Operator Panel

The Operator Panel is mounted on the wall remote from the Control Unit.

If the Operator Panel is mounted separate from the Control Unit, a supplied cable must be run from the Control Panel to the Operator Panel. Where local codes require, a separate 2x4 junction box should be mounted to the left of the mounting stud above the power supply box. Refer to the supplied mounting template for specific location.

## Installation Procedures

### Preparing to Install the JB-70

#### Check Pre-installation Requirements

Prior to beginning the installation, be sure that all pre-installation requirements have been completed. This includes confirming that the wall support requirements are adequate for mounting the unit and that the electrical power requirements and wire locations are proper.

**Note:** Progeny recommends that the JB-70 Dental X-Ray System be connected to dedicated wiring and permanently grounded. The installer must determine the suitability of use of a line cord at the time of installation, ensuring proper grounding technique.

#### Gather Tools

- Metric Allen wrench set
- English (inch) Allen wrench set
- Screwdrivers (slot and Phillips)
- Awl
- 1 inch hole saw (needed for metal stud mount only)
- ¼ inch diameter 12 inch long drill bit (needed for metal stud mount only)
- 5/32 drill bit
- Torque wrench 0-40 ft-lb or equivalent
- Stud finder
- Crimping tool
- Bubble level (torpedo level)
- Drill driver and drill bits appropriate to type of wall mounting
- Sockets and ratchet driver appropriate to type of wall mounting
- Fluke model 73 DVM equivalent or better

#### Installation Time

The JB-70 Dental X-Ray System has been designed to be installed by one person in less than one hour, assuming that all pre-installation requirements have been met.

#### Open the Shipping Carton

The JB-70 Dental X-Ray system is shipped in a convenient two-level carton. The first level contains the items needed for the first part of the installation, including the Control Unit, Operator Panel, Horizontal Arm, mounting template, documentation, cables, and bags containing the mounting hardware, brake assembly plastic covers and additional hardware. The Articulating Arm and Tubehead Assembly is in the second level of the shipping carton, where it can remain until it is installed.



**Figure 13**  
**Two-level Carton**

**Packing List**

| Part Number  | Description                              | Quantity |
|--|--|----------|
| 30-A1001   | Articulated Arm Assembly                 | 1        |
| 30-A1004   | Control Unit Assembly                    | 1        |
| 30-A2021   | Operator Panel                           | 1        |
| 30-P0029   | Operator Panel Mounting Cradle           | 1        |
| 30-A2049   | Brake Assembly                           | 1        |
| 30-A2045 or  | JB-70 Plastic Parts Kit (Blue)           | 1        |
| 30-A2057   | JB-70 Plastic Parts Kit (Gray)           |          |
| 30-A2046   | JB-70 Mounting Hardware Kit              | 1        |
| 30-A2047   | JB-70 Miscellaneous Parts Kit            | 1        |
| 30-A2068   | Articulated Arm Brake Asm. Kit           | 1        |
| E1-13002   | Line Cord, 16/3 6' Wide                  | 1        |
| E1-13003   | 8 Cond. RJ45 to RJ45 25 ft.              | 1        |
| E1-13004   | 8 Cond. RJ45 to RJ45 6 in.               | 1        |
| 30-A2048   | JB-70 Documentation Kit                  | 1        |
| 30-P0076   | Installation Guide                       | 1        |
| <b>Note: Shipment Contains One of the Following Extension Arms Per Order</b> |  |          |
| 30-A2025   | Extension Arm, Long                      | 1        |
| 30-A2034   | Extension Arm, Short                     | 1        |
| 30-A2038   | Extension Arm, Compact                   | 1        |
| <b>Options</b>   |  |          |
| E1-13034   | 8 Cond. RJ45 to RJ45 50 ft.              |          |
| 30-08101   | Doorbell Switch                          |          |
| 30-08110   | Lighted Doorbell Switch                  |          |
| 30-A2041   | 8 inch Rectangular Cone                  |          |
| 30-A2035   | Touch-up Paint                           |          |
| 22-11466   | 8mm Adjustment Wrench                    |          |
| 22-11467   | Fluorescent Screen                       |          |
| 30-A2042   | 16-inch Mounting Plate                   |          |
| 00-02-0488   | FDA Form 2579                            |          |
| 30-A2080   | Service Kit 120 volt (Call for details)  |          |
| 30-A2081   | Service Kit 240 volt (Call for details)  |          |
| 30-A2082   | Service Kit VetVision (Call for details) |          |
| 30-A2099   | 4x4 Mount Kit                            |          |
| 30-A2152   | Series Exposure Switch Kit               |          |

## Installing the Control Unit on a Single Wood Stud Wall

### Mark and Drill Control Unit Mounting Holes

### SINGLE STUD INSTALLATION WITH THE “INSTALLATION GUIDE” (30-P0076).

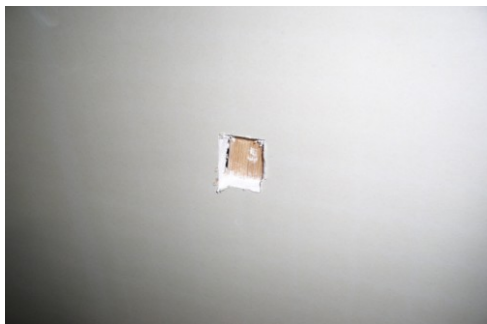
#### Introduction

The Installation Guide is intended to be a positive means of locating the center of a 2x4 wooden stud. The Installation Guide is a necessary part of the installation and must be used whenever single stud installations are performed. The Installation Guide is equipped with side tabs which can be removed if placement of the Guide is obstructed by an electrical box. During installations which include attachment to a 4x4 wooden stud, all of the tabs, on one side of the guide, can be removed in order to facilitate adequate placement and attachment.

1. Locate the wooden stud.



2. Make a small opening in the wall to positively identify the position of the wooden stud.



3. Draw an outline of the installation guide on the wall, ensuring that the vertical height matches the requirements set forth on the “Wall Mount Template” (30-S0003). Open the wall so that the installation guide will

rest directly on the wooden stud.



4. Place the installation guide on the wooden stud.



5. Drill two 5/32 inch diameter holes using the installation guide as a drill template.



6. Attach the wall mounted control, leaving the installation guide in place.





**Remove Control Unit Front Cover**

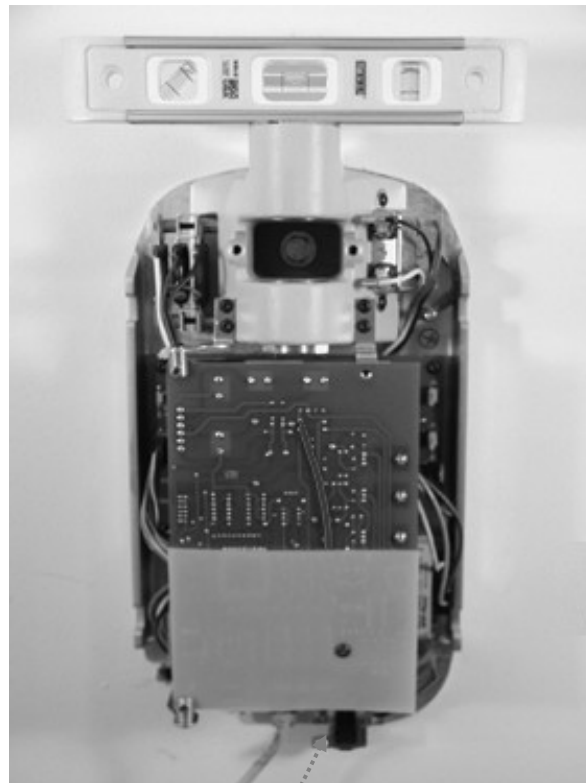
1. Open the shipping carton and locate the Control Unit in the first level of the carton.
2. Remove the Phillips screw from the front cover of the Control Unit.
3. Carefully remove the front cover.
4. Place the front cover and the screw in a safe location for later reassembly.

**Mount and Level the Control Unit**

1. Select the 3/8 inch 3-inch long lag screws and washers.  
**Note:** For concrete walls, the installer must supply the appropriate mounting bolts.
2. Put the upper lag screw and washer through the upper mounting hole of the Control Unit.
3. Place the Control Unit on the wall and loosely tighten the upper mounting bolt.
4. Put the lower lag screw and washer through the lower mounting hole of the Control Unit and loosely tighten. Be sure that the power wire extends through the opening at the bottom of the Control Unit.
5. Place a level on the Control Unit bearing parallel to the wall, as shown in Figure 14. Level the Control Unit.
6. Tighten the upper and lower lag screws to 14 to 18 ft-lbs.

**CAUTION!**

**Do not over tighten the lag screws. Over tightening the lag screws will damage the wooden stud and reduce the holding force.**



**Figure 14**  
**Leveling the**  
**Control Unit**

**For control of Wall Mount shift.**

After the Control has been leveled and the lag screws tighten, pre-drill this location for a #12 screw. Install and tighten the #12 screw

## Installing the Control Unit on a Dual Wood Stud Wall

### Mark and Drill Wall Plate Mounting Holes

The mounting template is a guide for locating where to drill the holes used to mount the wall plate to the wall. Carefully placing the mounting template for two stud mount installations on the wall will help ensure correct installation of the mounting plate and, hence, the Control Unit.

1. Using a stud finder, locate the center of the studs on which the wall plate will be mounted.
2. Place the mounting template for the two stud mount on the wall with the lower mounting holes 40 inches above the floor.
3. Place a level parallel to the vertical lines on the mounting template and adjust the mounting template until it is plumb.
4. Tape the mounting template to the wall.
5. Using an awl or other sharp object, punch through the mounting template to mark the location of the mounting holes.
6. Drill 5/32" pilot holes (for common pine studs) at marked locations.
7. Remove the mounting template from the wall and save for future use.

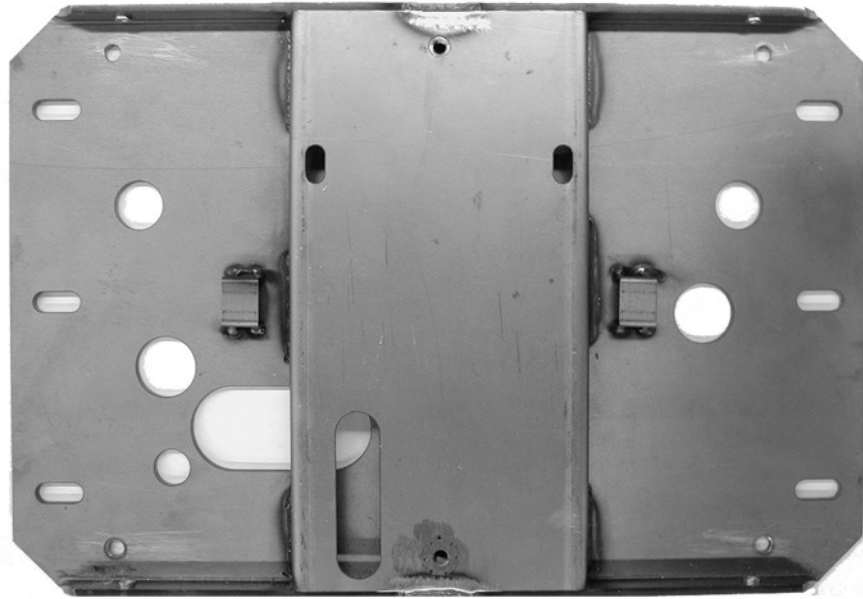
### Install the Wall Plate (30-A2042)

In the dual wood wall stud installation, the Control Unit is bolted to a wall plate that has been installed on two wood studs. The wall plate, shown in **Error! Reference source not found.**, is shipped separately from the JB-70.

1. Select the 3/8 inch 3-inch long lag screws and washers.
2. Put the lag screws and washers through the mounting holes on the wall plate and loosely tighten. Be sure that the power wire extends through the opening in the wall plate.
3. Level the wall plate.
4. Tighten the lag screws to 14 to 18 ft-lbs.

#### **CAUTION!**

**Do not over tighten the lag screws. Over tightening the lag screws will damage the wooden stud and reduce the holding force.**



**Figure 15**

**Mounting Plate for  
Dual Stud Wall  
Mounts**

**Remove Control  
Unit Front Cover**

1. Open the shipping carton and locate the Control Unit in the first level of the carton.
2. Remove the socket flathead screw from the front cover of the Control Unit.
3. Carefully remove the front cover.
4. Place the front cover and the screw in a safe location for later reassembly.

**Mount the  
Control Unit**

1. Select the 5/16 inch 3/4 inch long socket cap screws and washers.
2. Put the upper screw and washer through the upper mounting hole of the Control Unit.
3. Place the Control Unit on the wall and loosely tighten the upper screw.
4. Put the lower screw and washer through the lower mounting hole of the Control Unit and loosely tighten. Be sure that the power wire extends through the opening at the bottom of the Control Unit.
5. Place a level on the Control Unit bearing parallel to the wall. Level the Control Unit.
6. Tighten the upper and lower screws.
7. After the JB-70 is installed, slide covers on the wall plate and screw on.

## Installing the Control Unit on a Metal Stud Wall

### Mark and Drill Wall Plate and Support Plate Mounting Holes

The mounting template is a guide for locating where to drill the holes used to mount the wall plate and support plate to the wall. Carefully placing the mounting template on the wall will help ensure correct installation of these plates and, hence, of the Control Unit.

1. Using a stud finder, locate the center of the stud on which the Control Unit will be mounted.
2. Place the mounting template for the dual stud mount on the wall with the lower mounting holes 40 inches above the floor.
3. Place a level parallel to the vertical lines on the mounting template and adjust the mounting template until it is plumb.
4. Tape the mounting template to the wall.
5. Using an awl or other sharp object, punch through the mounting template to mark the location of the mounting holes.
6. Drill 1/4 inch pilot holes at marked locations.
7. Drill 1 inch clearance holes.
8. Remove the mounting template from the wall and save for future use.

### Reinforce Metal Stud Wall

Filler material is added to the wall to prevent the metal stud wall from being crushed during installation.

1. Cut an access hole 6 inches by 10 inches in size between the clearance holes.
2. Insert two 4x4 wooden studs in the access hole. Attach the studs to the rear drywall surface with drywall screws.

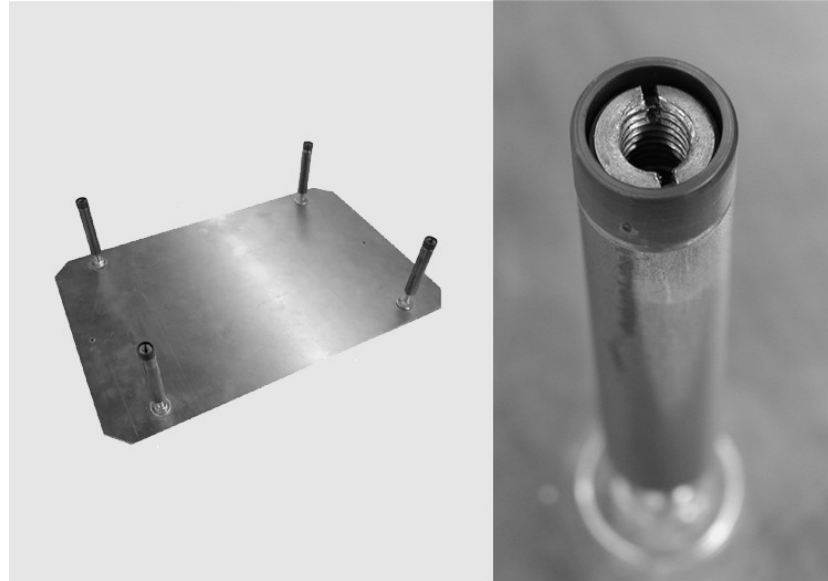
#### **CAUTION!**

**The sheet metal stud wall must be secure to hold a load of 850 ft. lbs. (118 kg.m.).**

### Assembling and Mounting the Support Plate (30-A2043)

In the metal wall stud installation, the Control Unit is bolted to a wall plate that has been installed to the support plate shown in Figure 15 that has been installed to the support plate shown in Figure 16. The wall and support plates are shipped separately from the JB-70.

1. Insert the carriage bolts into the support plate holes.
2. Put the washer and nuts on the carriage bolts.
3. Screw the threaded standoff onto the carriage bolts with the plastic buffer away from the back plate.
4. Using a 5/32 Allen key, insert the set screw into the threaded standoff. Screw the set screw until just below the slot in the threaded standoff, but do not tighten.
5. Using two sheet metal screws, mount and level the support plate through the pilot holes on the back side of the wall. Tighten the sheet metal screws with the screw driver.
6. On the front side of the wall, using a straight-blade screw driver, adjust the threaded standoffs until the plastic part is flush with the drywall.
7. Tighten the set screws in the threaded standoffs to lock them in place.



**Figure 16**  
**Support Plate for**  
**Metal Stud Wall**  
**Mount**

### **Install the Wall Plate (30-A2042)**

1. Select the 5/16 inch 1 inch long hex bolts.
2. Put the hex bolts through the mounting holes on the wall plate and loosely tighten. Be sure that the power wire extends through the opening in the wall plate.
3. Level the wall plate.
4. Tighten the hex bolts

### **Remove Control Unit Front Cover**

1. Open the shipping carton and locate the Control Unit in the first level of the carton.
2. Remove the socket flathead screw from the front cover of the Control Unit.
3. Carefully remove the front cover.
4. Place the front cover and the screw in a safe location for later reassembly.

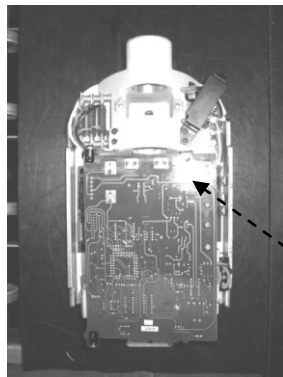
### **Mount the Control Unit**

1. Select the 5/16 inch 3/4 inch long socket cap screws and washers.
2. Put the upper screw and washer through the upper mounting hole of the Control Unit.
3. Place the Control Unit on the wall and loosely tighten the upper screw.
4. Put the lower screw and washer through the lower mounting hole of the Control Unit and loosely tighten. Be sure that the power wire extends through the opening at the bottom of the Control Unit.
5. Place a level on the Control Unit bearing parallel to the wall. Level the Control Unit.
6. Tighten the upper and lower screws.
7. After the JB-70 is installed, slide covers on the wall plate and screw on.

## Installing the Horizontal Arm and Brake Assembly

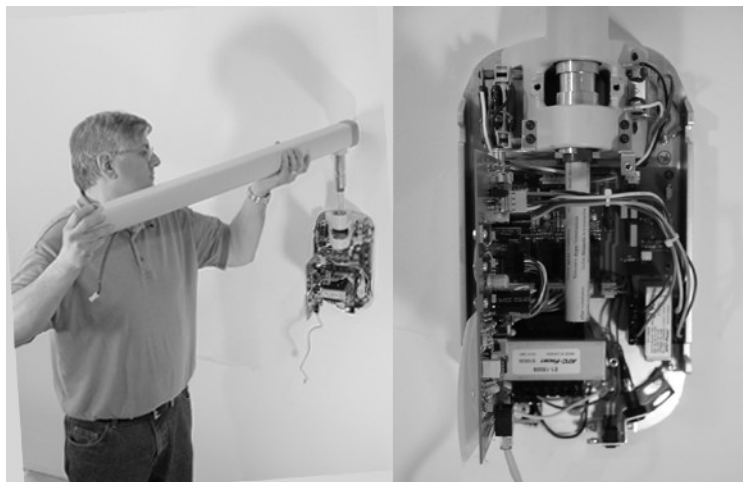
1. On the Control Unit, remove the button-head screw from the Logic Board, PCB 30-08002, as shown in Figure 17. Put the screw in a safe location for later use.
2. Locate the Horizontal Arm in the top level of the shipping carton.
3. Remove the Horizontal Arm from the shipping carton. **Do not remove** the cardboard tube around the wires. Shove the cardboard tube snugly into the shaft of the Horizontal Arm.
4. Do not lubricate shaft on horizontal arm or bearings in control unit.
5. Insert the cardboard tube enclosing the wires into the opening in the top of the Control Unit.
6. Insert the Horizontal Arm completely into the Control Unit, as shown in Figure 8. Ensure that the Horizontal Arm is firmly seated in place.
7. Remove the cardboard tube to free the wires. Discard the cardboard tube.  
**Note:** Do not make the wire connections at this time.
8. Locate the brake assembly bag. As shown in Figure 9, install and loosely tighten the brake assembly in order to put a small amount of drag on the rotation of the Horizontal Arm and to keep the Horizontal Arm from lifting out.

**Figure 17**  
Removing the  
Button Head Screw

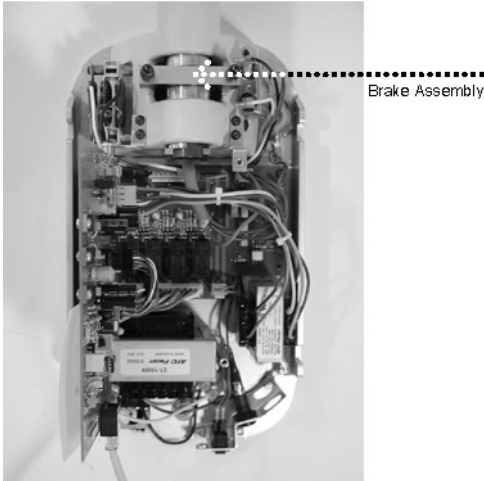


Button Head Screw

**Figure 18**  
Installing the  
Horizontal Arm



**Figure 19**  
**Installing the Brake**  
**Assembly**





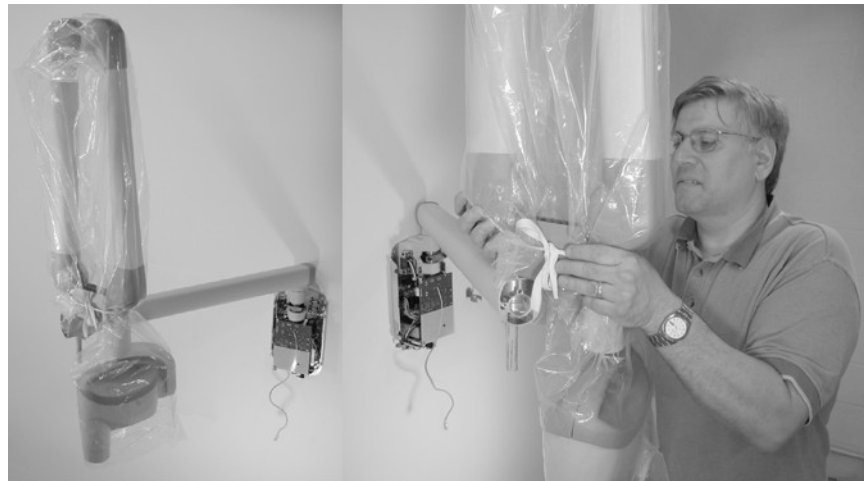
## Installing the Articulating Arm and Tubehead Assembly

1. Remove the top level packing material from the shipping carton to gain access to the Articulating Arm and Tubehead Assembly. **Do not remove** the cardboard tube enclosing the cable wires.
2. Remove the Articulating Arm and Tubehead Assembly from the shipping carton.  
**Note:** The Tubehead and Articulating Arm are installed as a single unit.

### CAUTION

**Do not remove the tie holding the Articulating Arm closed. Removing the tie will cause the Articulating Arm to spring open, potentially causing personal injury.**

3. Do not lubricate shaft on articulated arm or bearings in control unit.
4. Position the Articulating Arm above the Horizontal Arm.
5. Carefully route the cardboard tube with the arm cable plug through the opening in the Horizontal Arm.
6. Insert the shaft of the Articulating Arm into the opening in the Horizontal Arm, as shown in Figure 20.
7. Press down until the shaft is completely seated in the Horizontal Arm.
8. Remove the cardboard tube to free the wires. Discard the cardboard tube.
9. Untie the Articulating Arm and remove the plastic covering.

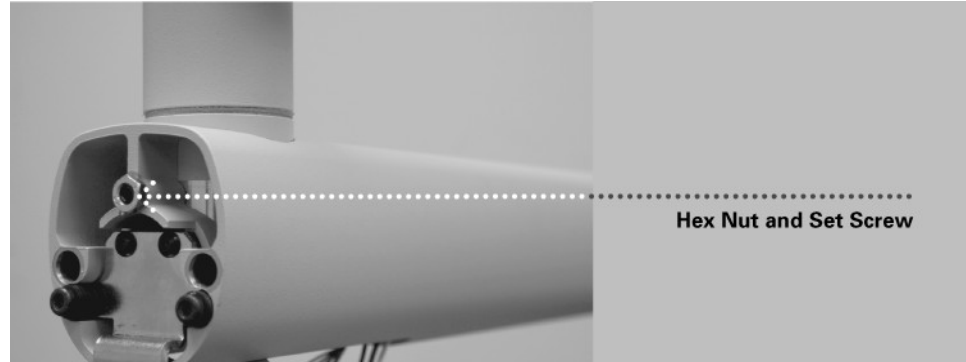


**Figure 20**  
Installing the  
Articulating Arm  
and Tubehead  
Assembly

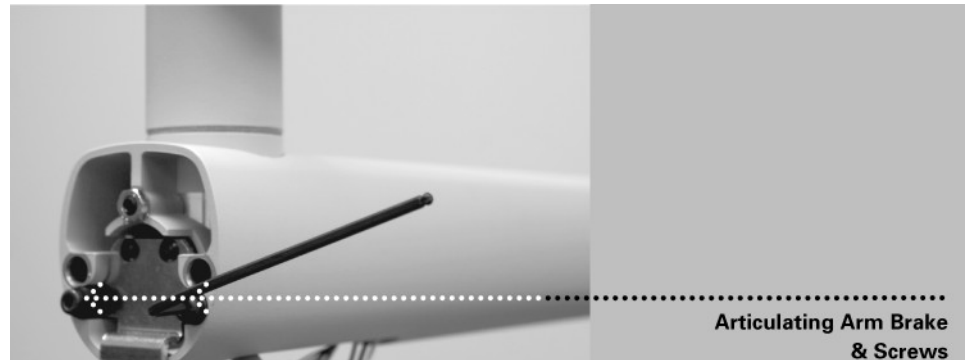
## Install the Articulating Arm Brake Assembly

1. Locate the Articulating Arm brake assembly (30-A2068).
2. Insert the M6 x 25 mm long set screw, as shown in Figure 21. Using a 3 mm Allen wrench, tighten the screw fully and back off  $\frac{1}{4}$  turn. Install and tighten the supplied hex nut.
3. Using a 3 mm Allen wrench, install the Articulating Arm brake. Tighten screws until the Articulating Arm brake comes into contact with the shaft of the Articulating Arm. If additional friction is required to prevent drifting, turn the two screws evenly  $\sim\frac{1}{4}$  turn at a time until drift stops, as shown in Figure 22.

**Figure 21**  
Installing the Hex Nut and Set Screw



**Figure 22**  
Adjusting the Articulating Arm Brake Assembly



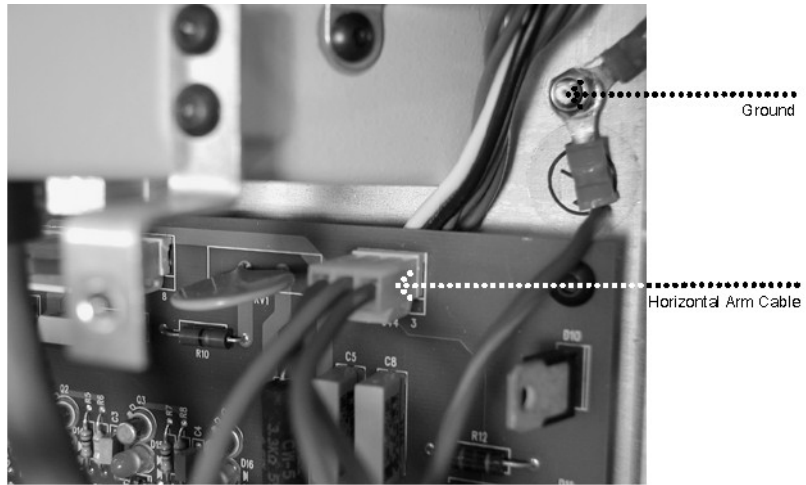
## Connecting the Cables

1. Connect the Articulating Arm cable connector to the Horizontal Arm cable connector, as shown in Figure 23.
2. Once the connection is made, dress the cable and push into the opening in the Horizontal Arm.
3. Connect the cable from the Horizontal Arm to point J44 on the Power Board, PCB 30-08004 in the Control Unit, as shown in Figure 24.  
**Note:** The plug must be properly oriented. Be sure that the tabs on the connector are down.
4. Remove the nut and washer and connect the ground wire.
5. Replace the nut and washer.
6. If required, locate conduit mounting plate and three M4 x 0.7 nylok hex nuts in mounting hardware kit, otherwise proceed to step 8.
7. Attach conduit to conduit mounting plate and mount the conduit mounting plate over the three studs in the lower left corner of the chassis of the control unit.
8. Connect the hot (black) wire from the main power supply to the terminal block at position 'L'.
9. Connect the neutral (white) wire from the main power supply to the terminal block at position 'N'.
10. Using a crimping tool, crimp the ring terminal on the end of the ground wire.
11. Remove the ground nut and washer.
12. Route the ground wire behind the fuse and switch. Place on the ground.
13. Replace the nut and washer.

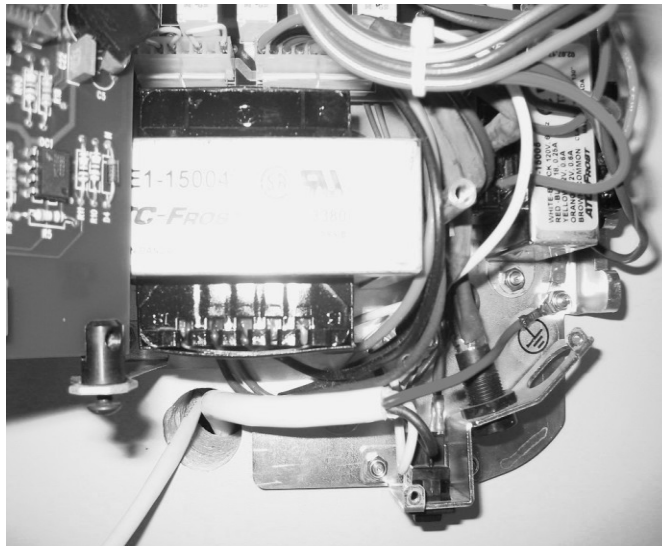


**Figure 23**  
Connecting the  
Articulating Arm  
and Horizontal Arm  
Cables

**Figure 24**  
Connecting the  
Horizontal Arm  
Cable to the Power  
Board



**Figure 25**



## Electrical Verification

### 50 and 60 Hertz Operation

There is a jumper setting on the Logic Board, PCB 30-08002, which is labeled “JP2- 50 60 Hz”. With power off, verify that this jumper setting has a shunt in the correct position for the line voltage frequency.

### Optional 12 inch Cone Operation

The JB-70 Dental X-Ray System is factory set for use with the standard supplied 8 inch (20 cm) Cone. A 12 inch (30 cm) Cone (30-A2033) is available. Using the longer Cone requires the use of longer exposure times, which are selected by the jumper setting JP1 on the Logic Board, PCB 30-08002. It is labeled “CONE LG SM”. Ensure that the shunt for this jumper is in the SM position for the 8 inch (20 cm) Cone and in the LG position for the 12 inch (30cm) Cone. When the system power is turned on, this jumper will be monitored to determine which Cone is in use.

### kVp and mA X-Ray Output

The kVp and mA x-ray output are not adjustable. No calibration is required.

The mA may be verified with a fast-responding DC milliammeter.

1. Connect the DC milliammeter to TP3 (mA) on the Power Board, PCB 30-08004, and to chassis ground.
2. Set the exposure time to 1.65 seconds.
3. Make three or four exposures.
4. If the measurement is not consistent, the amp meter is not fast enough to process the signal.

To measure kVp, a non-invasive kVp meter may be used. However, the meter must be set to ignore the pre-heat bias of 185 milliseconds prior to exposure. See Measurement Bias in the Specification section at the end of this manual.

### Verify Correct 50/60 Hz and Cone Size Jumper Settings

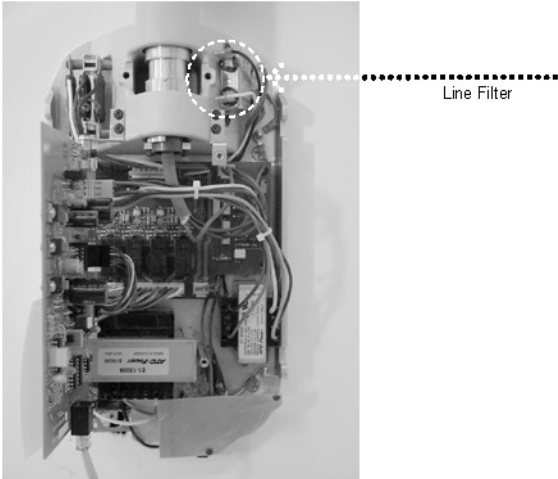
1. Remove the Operator Panel from the shipping carton. Using either the short or long cable, temporarily connect the Operator Panel to the Control Unit.
2. Disconnect the cable coming from the Horizontal Arm by removing the connector from point J44 on the Power Board, PCB 30-08004. The cable is disconnected in order to prevent x-ray exposure during this procedure.
3. Power on the system.
4. The Operator Panel indicates the current settings by displaying one of the following:

| 50/60 Hz<br>Operation | 8 or 12 inch<br>Cone |
|-----------------------|----------------------|
| 60                    | 08                   |
| 60                    | 12                   |
| 50                    | 08                   |
| 50                    | 12                   |

### Verify Input Voltage

1. Measure the input voltage across the line filter, shown in Figure 26. The reading should be within the range shown below for the system.

|                                    |                                    |
|------------------------------------|------------------------------------|
| <b>120V System</b><br>120V +/- 10% | <b>230V System</b><br>230V +/- 10% |
|------------------------------------|------------------------------------|



**Figure 26**  
**Verifying Input**  
**Voltage at the Line**  
**Filter**

**Notice:**

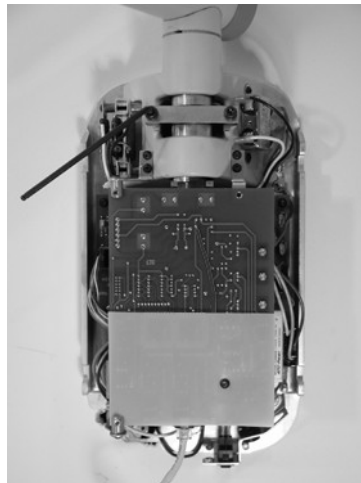
Accurate adjustment of this value is essential to producing the correct operating kilovoltage during patient examinations.

**Verify Output Voltage**

1. Measure the output voltage across TP1 and TP2 on the Power Board, PCB 30-08004. The reading should be 130VAC +/- 3V (260VAC +/-6V for the 230V system).
2. If the output voltage is not within the specified range, the system software can be used to adjust it. To adjust the output voltage, follow these steps:
  - a. Using the Time Selection buttons on the Operator Panel, set the exposure time to the shortest setting.
  - b. Press and hold the Exposure button until the exposure time is complete as indicated by the visual and audio indicators.
  - c. Repeat step b two or three times.
3. If, after several iterations, the correct output voltage cannot be achieved, use the Adjusting the Line Voltage Compensation Circuit procedure in the Troubleshooting section of this manual.
4. Power off the system.
5. Replace the button head screw on the Logic Board, PCB 30-08002.
6. Reconnect the cable coming from the Horizontal Arm to point J44 on the Power Board, PCB 30-08004.
7. Disconnect the Operator Panel.

**Mechanical Adjustments****Horizontal Arm Adjustment**

1. Locate the brake assembly at the top of the Control Unit. The brake assembly has a screw on either side of a clamping bar over the Horizontal Arm pivot post.
2. Using a 4 mm Allen wrench, as shown in Figure 27, tighten the screws equally to apply adequate braking to the pivot post so that Horizontal Arm begins to move after the Articulating Arm.



**Figure 27**  
**Tightening the Brake**

**Additional Adjustments**

The balance and friction of the Articulating Arm are set initially at the factory. During the installation process, check the balance and friction. When moving the Tubehead, the Articulating Arm should be steady in all positions and move before the Horizontal Arm. If adjustments are necessary, follow the adjustment procedures in the Troubleshooting section.

**Note:** The mechanical adjustments should not be used to compensate for a system that is not properly leveled on the wall.

**Installing the Control Unit Front Cover and the Operator Panel****Important Note**

The Operator Panel can be installed on the Control Unit or remote from the Control Unit. Installation of the Operator Panel on the Control Unit may require the purchase and use of the coil-cord hand switch option, 30-A2040.

In order to comply with the regulations and proper x-ray practices, the Operator Panel must be located where the operator can view both the patient and the technique factors prior to the exposure.

**On the Control Unit**

1. Verify that the short cable is connected to the bottom of the Logic Board, PCB 30-08002. If the cable is not connected, plug in the short cable.
2. Feed the cable through the front cover of the Control Unit.
3. Place the bottom of the front cover on the Control Unit and pop the top of the cover into place, as shown in Figure 28.
4. Replace the screw on the front cover of the Control Unit.
5. Remove the Operator Panel from the shipping carton.
6. Plug the cable into the bottom of the Operator Panel.
7. Snap the Operator Panel into place on the front cover of the Control Unit. (Figure 29)



**Figure 28**  
Placing the Cover  
on the Control Unit



**Figure 29**  
**Snapping in the**  
**Operator Panel**



### Remote Operator Panel

In the remote location, the Operator Panel snaps to the Operator Panel mounting cradle, which is first mounted on the wall.

1. Place and level the mounting template at eye level in the location where the Operator Panel is to be installed. Tape the mounting template to the wall.
2. Using an awl or other sharp object, punch through the mounting template to mark the location for the bolts for the Operator Panel mounting cradle.
3. Drill pilot holes at marked locations. With a drywall knife, cut an opening as shown on the mounting template.
4. Remove the mounting template from the wall.
5. Using the anchors and screws from the mounting hardware bag, install the Operator Panel mounting cradle in the position marked.
6. Locate the 25-foot remote control cable in the top level of the shipping carton.
7. Run the remote control cable, in compliance with local codes, from the intended location of the remote Operator Panel to the back of the Control Unit.
 

**Note:** The cable can also be run to an electrical box or opening at the top left of the wall plate assembly. A sufficient length of cable should be left available to bring the remote cable out to the bottom front of the Control Unit.
8. Plug the remote control cable into the bottom of the Control Unit Logic Board, PCB 30-08002.
9. Place the bottom of the front cover on the Control Unit and pop the top of the cover into place.
10. Replace the screw on the front cover of the Control Unit.
11. Place the Progeny cover plate over the top opening and the small trim cover over the bottom opening.
12. Locate the Operator Panel in the top portion of the shipping carton.
13. Connect the other end of the remote cable to the left plug (as viewed from the back) on the bottom of the Operator Panel.
14. Carefully dress the white cable back into the wall.
15. Snap the Operator Panel to the mounting cradle, as shown in Figure 30.

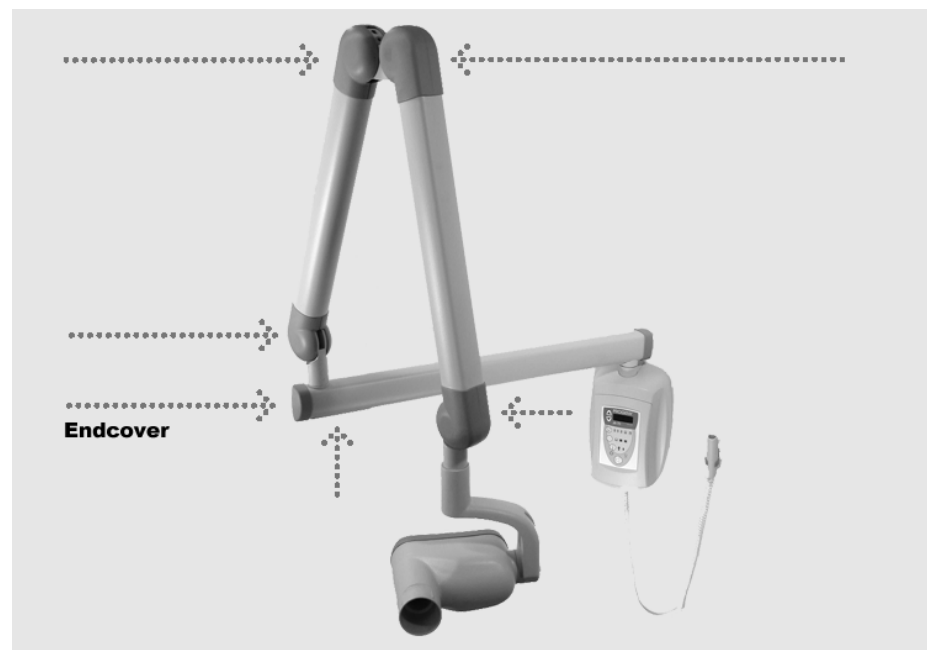
**Figure 30**  
**Snapping the**  
**Operator Panel to**  
**the Operator Panel**  
**Mounting Cradle**



## Installing Plastic Covers

The end cap for the Horizontal Arm is shipped in the bag of plastic parts and is put on as part of the installation procedures. End caps for the Articulating Arm are shipped installed but are removable to perform mechanical adjustments. The cable access cover is placed over the cable connection underneath the Horizontal Arm. Cover locations are shown in Figure 31.

1. Place the plastic cover from the miscellaneous plastic bag on the end of the Horizontal Arm.
2. Install the cable access cover over the Horizontal Arm opening using two Phillips flat-head screws.



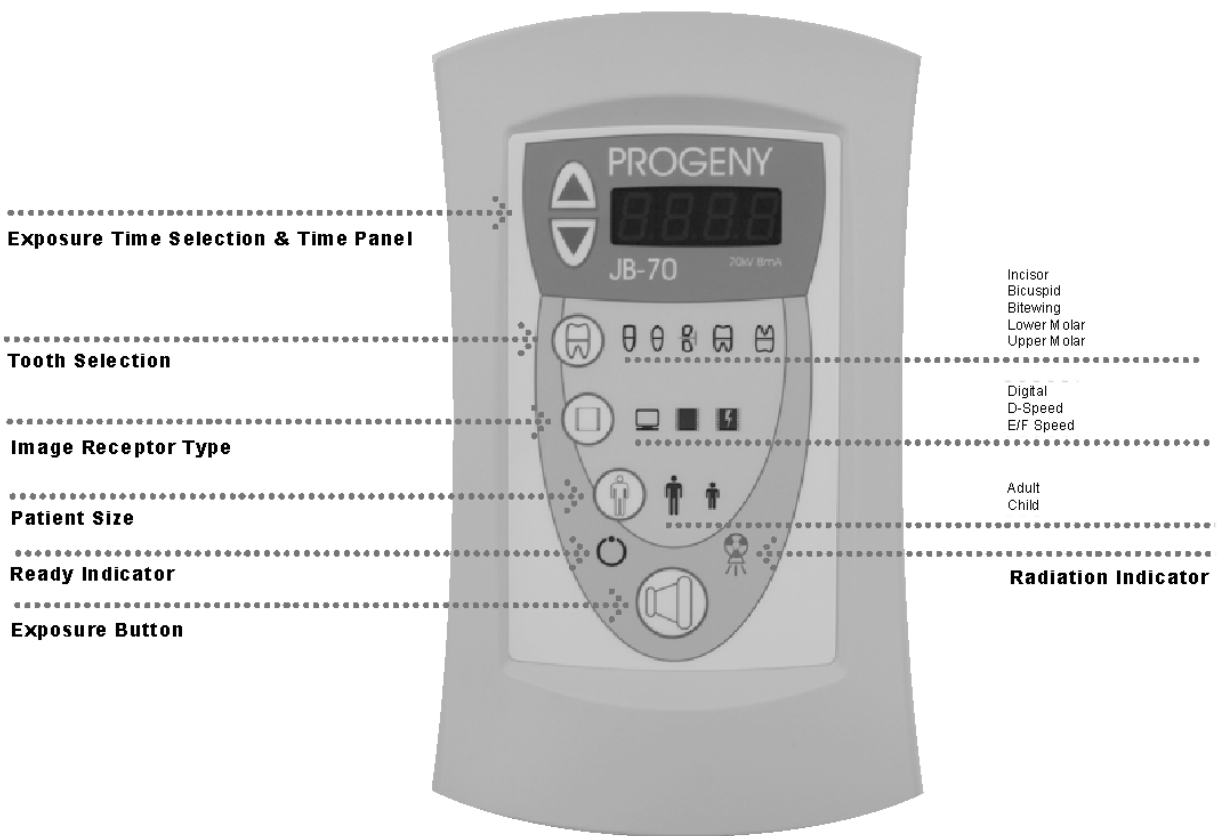
**Figure 31**  
**Cover Locations**

# Checking System Functions

## Important Notice

The following checks must be performed to complete the installation of the JB-70 Dental X-Ray System and as part of the recommended maintenance as indicated in the User Manual. Failure to perform these checks may result in an installation that does not comply with U.S. Radiation Performance Standards 21 CFR Subchapter J.

**If the JB-70 Dental X-Ray System does not perform the functions below, see the Troubleshooting section of this manual or contact Technical Support. Advise the owner that the system is NOT TO BE USED.**



JB-70 Operator Panel

Figure 32

| <b>System Function Checklist</b>                  |   | ✓ |
|---|---|---|
| <b>Wall Mounting</b>                              | Ensure that the wall support is adequate and that the system is properly mounted to the wall.   |   |
| <b>Labels</b>                                     | Ensure that all certified components bear labels that include the model and serial number, date of manufacture and a statement of certification as noted elsewhere in this manual.  |   |
| <b>Indication of Technique Factors</b>            | Verify that the "70 kV – 7 mA" is legible on the label of the Operator Panel.   |   |
| <b>Tubehead</b>                                   | Check for oil leaks or other evidence that could indicate internal damage. Replace the Tubehead, if necessary.  |   |
| <b>Tubehead Rotation</b>                          | Ensure that the Tubehead maintains its position around the horizontal axis while remaining easy to rotate and position. Also, check the vertical pivot of the Tubehead for easy movement while remaining in position after movement.  |   |
| <b>Suspension</b>                                 | Check that all movements are smooth and quiet. Verify that the Tubehead is properly counterbalanced for vertical drift and that the Horizontal and Articulating Arms do not drift horizontally.   |   |
| <b>Power Switch</b>                               | Verify that the switch is working properly and that the Ready Indicator is illuminated when the power switch is in the ON position.   |   |
| <b>Operator Panel Controls</b>                    | With the power switch, located at the base of the Control Unit, in the ON position, verify that a time indicates on the Operator Panel. Also, check the function of the selection buttons for Exposure Time, Tooth Selection, Image Receptor Type and Patient Size. Pressing a selection button should cause indicator lamps to indicate the selected item. |   |
| <b>Exposure Button</b>                            | Verify that the Exposure button on the Operator Panel is functioning properly. To make an exposure, press and hold the Exposure button until the Radiation Indicator is extinguished and the audible signal is no longer heard.   |   |
| <b>Exposure Indicators</b>                        | Make several exposures and verify that the Radiation Indicator illuminates and the audible signal is heard.   |   |
| <b>Premature Termination Indicator (Optional)</b> | Select the longest exposure time possible using the Exposure Time buttons. Initiate an exposure but release the Exposure button after a brief period of time before the timer terminates the exposure. Verify that the exposure time flashes, indicating a premature termination. Press the up or down time arrows to clear the flashing time display.      |   |
| <b>Coil-cord Hand Switch (Optional)</b>           | If a coil-cord hand switch is used, inspect the switch housing and coil cord for damage or wear. Replace if evidence of damage is present.  |   |
| <b>User Information</b>                           | Make certain that the user of the system has received a copy of the User Manual.  |   |

|                                     |  |  |
|-------------------------------------|--|--|
| <b>New Tube Seasoning Procedure</b> | <p>X-ray tubes which sit dormant for several months can become electrically unstable. To remedy this condition it is recommended to perform a “new tube seasoning procedure”. This process will establish stable high voltage operation and, will ultimately extend the life of the tube. Repeat this procedure before returning to normal operation any time the system has been unused for more than two months.</p> <ol style="list-style-type: none"> <li>1. Verify system operation.</li> <li>2. Energize the system.</li> <li>3. Select the exposure time of one second.</li> <li>4. Make ten exposures at this level, observing the normal cooling time.</li> <li>5. Proceed with the remainder of the installation.</li> </ol> |  |
|-------------------------------------|--|--|

### Your responsibilities as an installer and service engineer

**Verification of machine performance after installation** must be performed according to the guidelines identified in the “System Function Checklist” which may be found in the User Manual or, the Installation and Service Manual.

**Verification of machine performance after maintenance or repair** must be performed according to the guidelines identified in the “System Function Checklist” and the “Adjusting the Line Voltage Compensation Circuit” instructions which may be found in the Installation and Service Manual.

## Optional Installation Procedures

### Installing the Coil-cord Hand Switch Option (30-A2040)

#### Jumper Configuration for Coil-cord Hand Switch

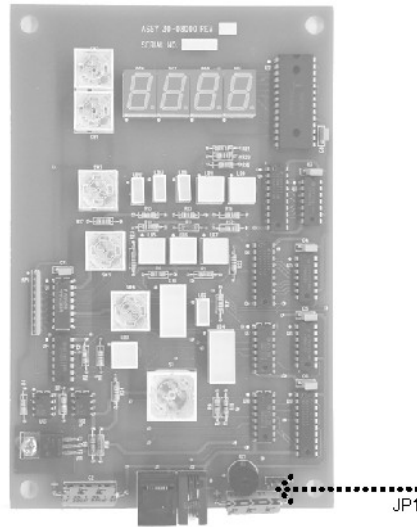
The JB-70 Dental X-Ray System can be installed with an optional coil-cord hand switch (30-A2040). The coil-cord hand switch is used to make exposures, in addition or replacing the use of the Exposure button. Installation of the coil-cord hand switch involves both connecting the hand switch into the connector on the bottom of the control panel.

**Note:** The coil-cord hand switch is not included with the standard system.

If the coil-cord hand switch is used, it may be required to disable the Exposure button on the control panel (consult your local laws). A jumper must be removed on the Operator Panel Board, PCB 30-08000, shown in Figure 33, to disable the operation of the hand switch.

1. Power the system off.
2. Remove the Operator Panel from its mounting on the Control Unit or wall plate.
3. Unplug the cable that connects the Operator Panel to the Control Unit.
4. With a Phillips screwdriver, remove the 4 screws from the back of the Operator Panel. Put the screws in a safe location for later use.
5. Remove the back cover from the Operator Panel. Lift out the Operator Panel Board, PCB 30-08000.
6. Locate point JP1 on the Operator Panel Board, PCB 30-08000.
7. To disable the use of the coil-cord hand switch, remove the shunt between 3 and 4.
8. To disable the use of the Exposure button on the operator panel, remove the shunt between 1 and 2.
9. To connect the coil-cord hand switch and the exposure button on the operator panel in series, remove both jumpers and place one of them on positions 2 and 3.
10. Put the Operator Panel Board, PCB 30-08000, back in position.
11. Put the cover on the back of the Control Panel using the 4 screws.

**Figure 33**  
**Operator Panel**  
**Board,**  
**PCB 30-08000**



**Connecting the**  
**Coil-cord Hand**  
**Switch—**  
**Operator Panel**  
**Located on**  
**Control Unit**

1. Remove the screw holding the front cover of the Control Unit in place. Place the screw in a safe location for later use.
2. Remove the front cover.
3. Cut out the notch on the base of the Control Unit front cover.
4. Route both the Operator Panel cable and the coil-cord hand switch through the hole in the bottom of the Control Unit front cover.
5. Place a loop of the coil cord into the notch.
6. Carefully reassemble the Control Unit front cover, keeping the coil-cord in the notch. Secure the front cover with the screw that was removed in step 1.
7. Locate the Operator Panel in the top portion of the shipping carton.
8. Connect the coil-cord hand switch to the right plug socket (as viewed from the back) on the bottom of the Operator Panel. Connect the short white cable to the left plug socket.
9. Carefully dress the two cables back into the front cover of the Control Unit.
10. Snap the Operator Panel into place on the front cover of the Control Unit.
11. Mount the bracket for the coil-cord hand switch in a convenient location.
12. Stow the coil-cord hand switch.

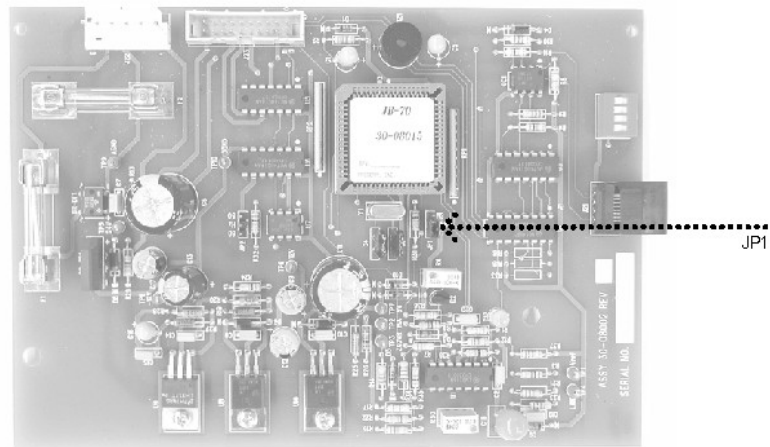
**Connecting the**  
**Coil-cord Hand**  
**Switch—**  
**Operator Panel**  
**in Remote**  
**Location**

1. Route the cable from the coil-cord hand switch through the hole in the wall mounting plate.
2. Place a loop of the coil cord into the notch.
3. Locate the Operator Panel in the top portion of the shipping carton.
4. Connect the coil-cord hand switch to the right plug socket (as viewed from the back) on the bottom of the Operator Panel. Connect the control cable to the left plug socket.
5. Carefully dress the two cables back into the wall.
6. Snap the Operator Panel into place on the wall mounting plate.
7. Mount the bracket for the coil-cord hand switch in a convenient location.
8. Stow the coil-cord hand switch.

## Installing the 12 inch Cone (30-A2033)

The JB-70 Dental X-Ray System is factory set for use with the standard supplied 8 inch (20 cm) Cone. The 12 inch (30 cm) Cone (30-A2033) is recommended when using parallel film positioning techniques. Using the longer Cone requires the use of longer exposure times, which are selected by the jumper setting JP1 on the Logic Board, PCB 30-08002, Figure 34. It is labeled "CONE LG SM". Ensure that the shunt for this jumper is in the SM position for the 8 inch (20 cm) Cone and in the LG position for the 12 inch (30cm) Cone.

When the system power is turned on, this jumper will be monitored to determine which Cone is in use.



**Figure 34**  
Logic Board, PCB  
30-08002



## Installing the Progeny Remote Exposure Switch (30-08101)

The lighted remote exposure switch (30-08101) is an option for the JB-70 Dental X-Ray System that allows the operator to make the exposure from a fixed location remote from the Control Unit. A single remote exposure switch can be used, or two switches can be used in series or in parallel. Two switches in series will require both switches to be pressed simultaneously in order to make an exposure. If two switches are used in parallel, only one needs to be pressed to make an exposure. Instructions for installing the remote exposure switch(es) are shipped with the remote exposure switch kits. Connect (2) 18 gauge wires from the remote switch to the terminal block J1, labeled "Remote Exposure Switch" on Logic Board 30-08002 (see Figure 36)

### Installing a Generic 2 Wire Remote Exposure Switch

Connect (2) 18 gauge wires from the remote switch to the terminal block J1, labeled "Remote Exposure Switch" on Logic Board 30-08002 (see Figure 36)

# Troubleshooting

## Performance Issues

### Light X-Ray

If the x-rays are lighter than desired, check the following:

1. Verify that the exposure time is appropriate for the examination. If using pre-programmed exposure times, make sure that the proper image receptor type is selected.
2. Verify proper operation of the film processor.

### No X-Ray

If no x-ray is produced, check the following:

1. Verify that the line cord (if one is in use) is properly connected.
2. Verify that the power switch is in the ON position.

## Checking System Power

If the system does not power on, perform the following steps.

1. With the power switch, located at the base of the Control Unit, in the ON position, check incoming power at L and N on the terminal block.
2. Power the system off.
3. Check the following system fuses:
  - a. Incoming line fuse located next to the power switch beneath the shield. Use a screwdriver to remove the fuse.
  - b. Fuse F1 on the Logic Board, PCB 30-08002.
  - c. Fuse F2 on the Logic Board, PCB 30-08002.
4. Replace any defective fuses with fuses of the same rating.

## Adjusting the Line Voltage Compensation Circuit

If the output to the Tubehead cannot be maintained at 130 VAC (250 VAC), adjust the line voltage compensation circuit. This circuit applies a constant voltage to the Tubehead on any input line voltage within 10% of the rated line voltage. If the incoming line varies from its nominal setting, the relays K1, K2, K3 and K4 on the Power Board, PCB 30-08004, will engage to adjust the voltage to the Tubehead. When the relays engage, their corresponding LEDs illuminate.

The relays add voltage to the incoming line to maintain a constant 130 VAC (250 VAC for the 230 volt unit) output, with a margin of +/- 3 VAC. The voltage added by the relays is as follows (230 volt unit values in parentheses):

- K1 adds 10 (20) volts
- K2 adds 6 (12) volts
- K3 adds 3 (6) volts
- K4 adds 1.5 (3) volts

For example, if the line is 110 VAC, K1, K2, and K3 may be on to create an output of  $110+10+6+3=129$  VAC.

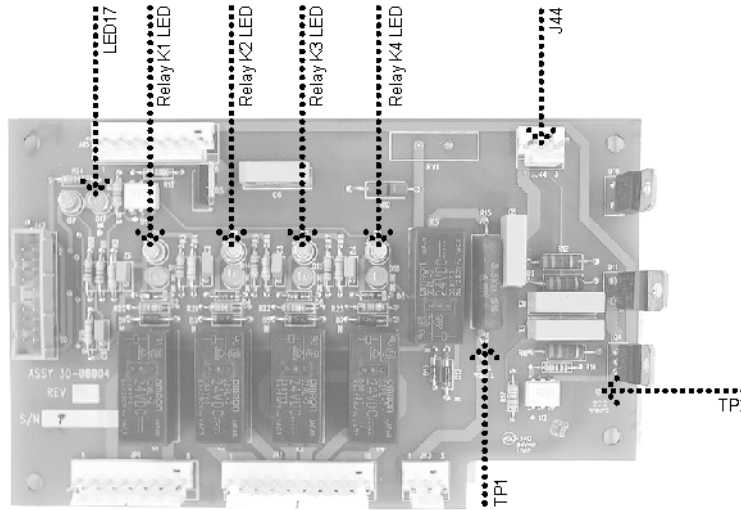
Perform the following steps to check and adjust this circuit.

1. Disconnect the cable coming from the Tubehead by removing the connector from point J44 on the Power Board, PCB 30-08004, shown in Figure 35. The cable is disconnected in order to prevent x-ray exposure during this procedure.
2. Power on the system.
3. Set the voltmeter to read AC volts.
4. Connect the voltmeter to the incoming AC Line Voltage at Line (L) and Neutral (N) on the terminal block. Note the voltage on the voltmeter.
5. Find the voltage in the table below. The corresponding Relays Engaged column indicates which relays should be engaged.
6. If the relays engaged do not correspond to the AC line voltage on the meter, adjust R30 on the Logic Board, PCB 30-08002 (Figure 36) in 1/4 to 1/8 turns. Allow your voltmeter +/- 2 volt variation.
7. After adjusting R30, press the Exposure button so that the software can communicate the adjustment to the circuit.
8. Recheck the LEDs for the relays to determine if the correct relays are engaged.
9. Repeat this process, if necessary, until the correct relays are engaged. If the correct relays are engaged and the output voltage is not 130 VAC +/- 3 volts (250 VAC +/- 6 volts), contact Progeny for technical support.
10. Reconnect the connector at point J44 on the Power Board, PCB 30-08004.
11. If the correct LEDs do not illuminate after performing this procedure, contact Technical Support.

The following table shows which relays are engaged for the corresponding input line voltages. The relays are engaged when the associated LED is illuminated.

| AC Line In  |             | Relays Engaged | Voltage Added |             |
|-------------|-------------|----------------|---------------|-------------|
| 120V System | 230V System |                | 120V System   | 230V System |
| 108         | 207         | K1, K2, K3, K4 | 20.5          | 41.0        |
| 109         | 209         | K1, K2, K3, K4 | 20.5          | 41.0        |
| 110         | 211         | K1, K2, K3, K4 | 20.5          | 41.0        |
| 111         | 213         | K1, K2, K3     | 19.0          | 38.0        |
| 112         | 215         | K1, K2, K4     | 19.0          | 38.0        |
| 113         | 217         | K1, K2, K4     | 19.0          | 38.0        |
| 114         | 219         | K1, K2         | 16.0          | 32.0        |
| 115         | 221         | K1, K3, K4     | 14.5          | 29.0        |
| 116         | 223         | K1, K3, K4     | 14.5          | 29.0        |
| 117         | 225         | K1, K3         | 13.0          | 26.0        |
| 118         | 227         | K1, K4         | 11.5          | 23.0        |
| 119         | 229         | K1, K4         | 11.5          | 23.0        |
| 120         | 230         | K1             | 10.0          | 20.0        |
| 121         | 231         | K2, K3         | 9.0           | 18.0        |
| 122         | 233         | K2, K4         | 10.5          | 21.0        |
| 123         | 235         | K2, K4         | 10.5          | 21.0        |
| 124         | 237         | K2             | 6.0           | 12.0        |
| 125         | 239         | K3, K4         | 4.5           | 9.0         |

|     |     |        |     |     |
|-----|-----|--------|-----|-----|
| 126 | 241 | K3, K4 | 4.5 | 9.0 |
| 127 | 243 | K3     | 3.0 | 6.0 |
| 128 | 245 | K4     | 1.5 | 3.0 |
| 129 | 247 | K4     | 1.5 | 3.0 |
| 130 | 249 | NONE   | 0   | 0   |
| 131 | 251 | NONE   | 0   | 0   |
| 132 | 253 | NONE   | 0   | 0   |



**Figure 35**  
**JB-70 Power Board,**  
**PCB 30-08004**

### Operator Panel Test

1. Locate the 4-position DIP switch, S1, on the Logic Board, PCB 30-08002, shown in Figure 36.
2. With power off, place position 1 in the ON position.
3. Turn power on and monitor the Operator Panel display.
4. The display will sequence through a series of test displays, as follows:
  - a. First, all the displayable characters are shown on the time display: 0000, 1111, 2222, 3333, 4444, 5555, 6666, 7777, 8888, 9999, HHHH, EEEE, LLLL, PPPP, ----.
  - b. The Tooth Selection button LED's will cycle in sequence for 10 cycles. Verify that each LED is illuminated in turn.
  - c. The Image Receptor Type LED's are cycled along with the Patient Size, Ready Indicator, and Exposure button LED's. Verify each LED is illuminated, in turn.
5. If the LEDs do not illuminate as described, replace the Logic Board, PCB 30-08002.
6. On completion of this procedure, turn the power off and return DIP switch, S1, position 1 to the OFF position.

---

## Power Board Tests

### Relay Check

1. Locate the 4-position DIP switch, S1, on the Logic Board, PCB 30-08002, shown in Figure 36.
2. With power off, place the DIP switch, S1, position 2 in the ON position.
3. Turn power on and monitor the LEDs above relays K1-K4 on the Power Board, PCB 30-08004, shown in Figure 35.
4. The LEDs will illuminate in turn.
5. If the LEDs do not illuminate as described, replace the Power Board, PCB 30-08004.
6. On completion of this procedure, turn the power off and return DIP switch, S1, position 2 to the OFF position.

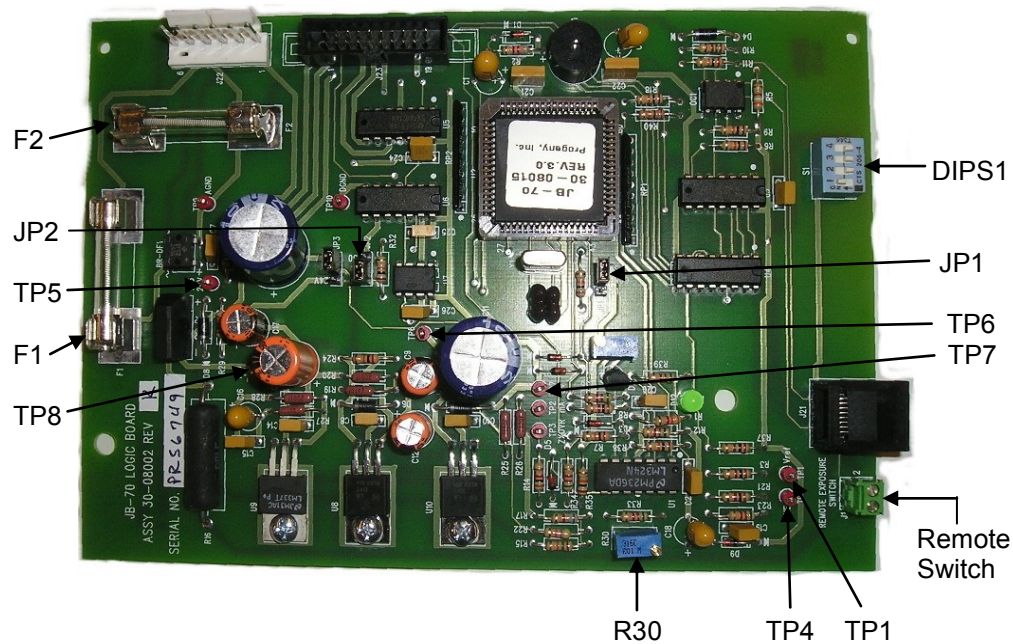
### Exposure Button Relay Check

1. With system power off, disconnect the cable coming from the Tubehead by removing the connector from point J44 on the Power Board, PCB 30-08004. The cable is disconnected in order to prevent x-ray exposure during this procedure.
2. Power on the system.
3. Press the Exposure button to verify that LED17 on the Power Board, PCB 30-08004, illuminates. The click of the relay should also be audible.
4. Power the system off.
5. Reconnect the connector at point J44 on the Power Board, PCB 30-08004.
6. If the LED does not illuminate or the relay does not click, replace the Power Board, PCB 30-08004.

## Logic Board Tests

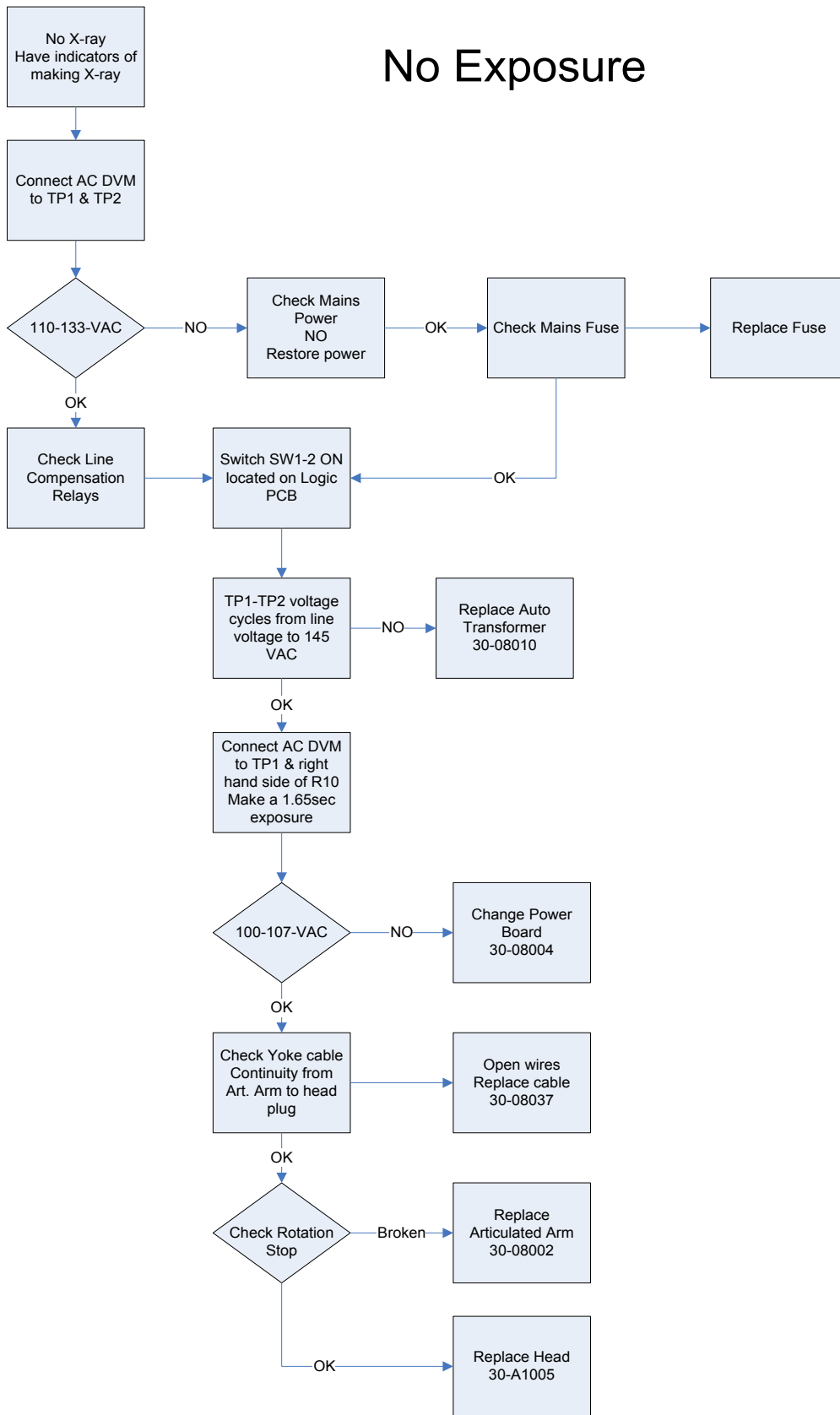
1. Verify that fuses F1 and F2 on Logic Board, PCB 30-08002, shown in Figure 36, are good.
2. Power the system on.
3. Locate the test points on the Logic Board, PCB 30-08002.
4. Set the voltmeter to the DC VOLTS scale
5. Place the reference black lead on DGND test point.
6. Place the red lead on the following test points and monitor the results.
7. If the reading is not within the range for the test point, follow the action indicated.

| Test Point | Verify reading      | Action  |
|------------|---------------------|---|
| TP7 5V     | 5V +/- .05V         | Check fuses. If the fuses are good, call Technical Support. |
| TP6 12V    | 12V +/- .1V         | Check fuses. If the fuses are good, call Technical Support. |
| TP8 -12V   | -12V +/- .1V        | Check fuses. If the fuses are good, call Technical Support. |
| TP5 24V    | 28V +/- 2V          | Check fuses. If the fuses are good, call Technical Support. |
| TP1 Vref   | 4.95V +/- 0.05V     | Adjust potentiometer R4.                                    |
| TP4 Line   | 4.5 volts +2V, - 1V | This voltage is dependant on the incoming line.             |

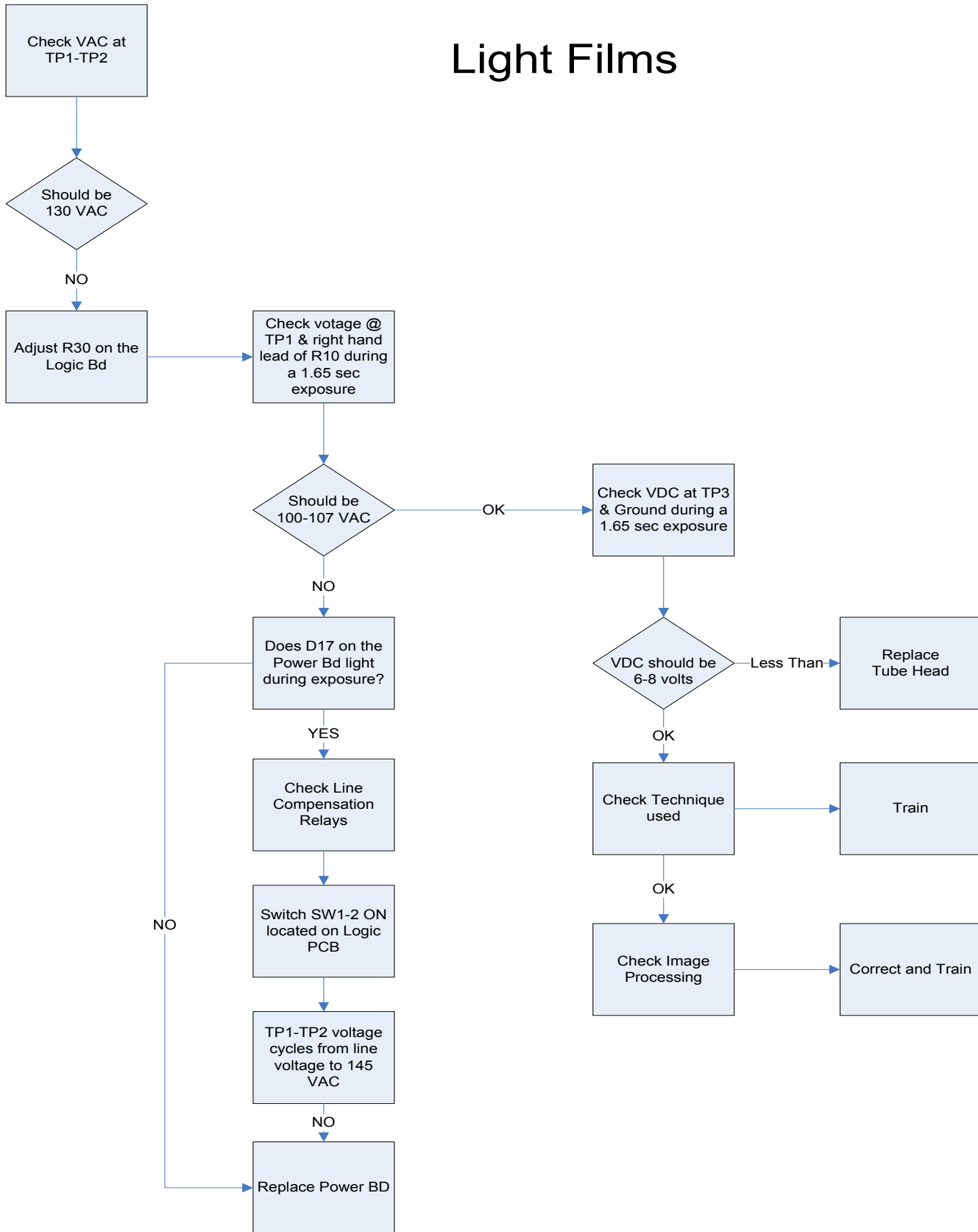


**Figure 36**  
Logic Board, PCB  
30-08002

# No Exposure

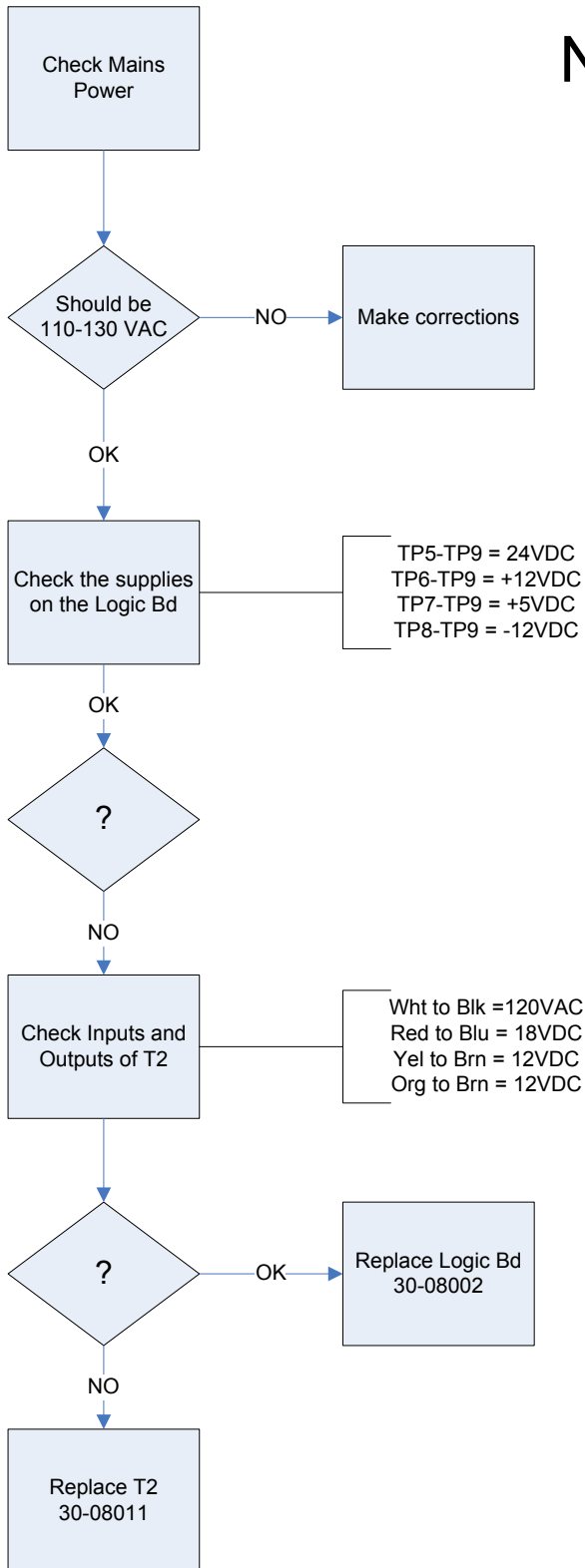


# Light Films





# No Display



**Your responsibilities as an installer and service engineer**

**Verification of machine performance after installation** must be performed according to the guidelines identified in the “System Function Checklist” which may be found in the User Manual or, the Installation and Service Manual.

**Verification of machine performance after maintenance or repair** must be performed according to the guidelines identified in the “System Function Checklist” and the “Adjusting the Line Voltage Compensation Circuit” instructions which may be found in the Installation and Service Manual.

## Mechanical Adjustments

### Determining the Necessary Adjustment

The balance and friction of the Articulating Arm and the friction of the Tubehead are set initially at the factory. During the installation process, check the balance and friction. When moving the Tubehead, the Articulating Arm should be steady in all positions and move before the Horizontal Arm.

**Note:** The mechanical adjustments should not be used to compensate for a system that is not properly leveled on the wall.

### Tubehead Movement

The movement of the Tubehead is set in the factory and cannot be adjusted.

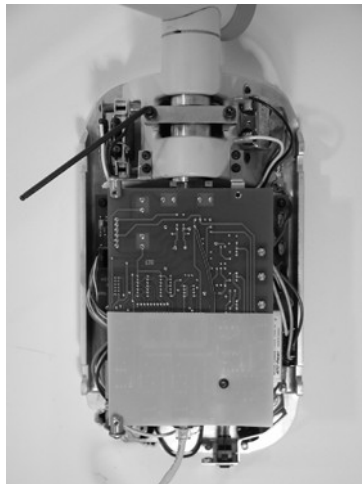
### Horizontal Arm Horizontal Movement

Note: If performing this adjustment as part of the initial installation of the JB-70, omit steps 1-3.

3. Remove the screw from the Control Unit front cover.
4. Carefully remove the front cover.

Note: If the Operator Panel is installed on the Control Unit, carefully keep the Operator Panel together with the front cover.

5. Unplug the cable connectors and set the front cover aside.
6. Locate the brake assembly at the top of the Control Unit. The brake assembly has a screw on either side of a clamping bar over the Horizontal Arm pivot post.
7. Using a 4 mm Allen wrench, as shown in Figure 37, tighten the screws equally to apply adequate braking to the pivot post so that Horizontal Arm begins to move after the Articulating Arm.
8. Replace and re-connect the front cover of the Control Unit. Replace the screw on the front cover.



**Figure 37**  
Tightening the Brake

**Articulating Arm  
Horizontal  
Movement**

1. Remove the plastic cover on the end of the Horizontal Arm nearest the Articulating Arm.
2. Locate the friction screw. Using a 3 mm Allen wrench, as shown in Figure 38, tighten or loosen as necessary to get proper movement without unwanted horizontal movement of the Articulating Arm.

**CAUTION: Do not attempt to adjust any other screws in the Horizontal Arm.**



**Figure 38  
Adjusting  
Articulating Arm  
Horizontal  
Movement**

**Alternative Horizontal Arm Brake Assembly**

3. Locate the friction assembly screws. Using a 3 mm Allen wrench, as shown in Figure 39, tighten or loosen screws as necessary to get proper movement without unwanted horizontal movement of the Articulating Arm.

**CAUTION: Do not attempt to adjust any other screws in the Horizontal Arm.**



Tighten screws evenly

**Figure 39  
Adjusting  
Articulating Arm  
Horizontal  
Movement  
(Alternative Version)**

**Outside  
Articulating Arm  
Vertical  
Movement**

1. Remove the plastic trim covers from the end of the Articulating Arm nearest to the Tubehead.
2. Position the Articulating Arm with the arm nearest the Tubehead fully upward.
3. Insert a 9-inch long 8 mm Allen wrench (T-handle) into the adjustment nut, as shown in Figure 40. Turning the wrench clockwise will cause the Control Unit side of the Articulating Arm to lift. Turning it counterclockwise will cause it to drop.
4. Adjust as necessary until the Control Unit side of the Articulating Arm no longer drifts.
5. Replace the plastic covers on the end of the Articulating Arm.



**Figure 40  
Adjusting Vertical  
Movement of the  
Articulating Arm**

**Control Unit Side  
of Articulating  
Arm Balance  
Adjustment**

1. Remove the plastic covers at the top of the Articulating Arm.
2. Position the Articulating Arm at a 45-degree angle.
3. Place a 9-inch long 8 mm Allen wrench (T-handle) into the adjustment nut inside the Articulating Arm, as shown in Figure 41. Turning the wrench clockwise will cause the Control Unit side of the Articulating Arm to lift. Turning it counterclockwise will cause it to drop.
4. Adjust as necessary until the Control Unit side of the Articulating Arm no longer drifts.
5. Replace the plastic covers on top of the Articulating Arm.



**Figure 41  
Adjusting  
Articulating Arm  
Balance**

### Articulating Arm Friction Adjustments

The JB-70 has four friction adjustment points located at the four pivot points of the Articulating Arm. These friction points can be adjusted to reduce/increase the force needed to position the Articulating Arm.

1. Remove the plastic covers on the Articulating Arm to reveal the adjustment points.
2. Using a 2 mm Allen wrench, as shown in Figure 42, tighten both screws evenly at each adjustment point until the movement of the Articulating Arm is as desired. Do not loosen adjustment points so far as to allow the Articulating Arm to drift.



Figure 42  
Friction Adjustments

## Obtaining Technical Support

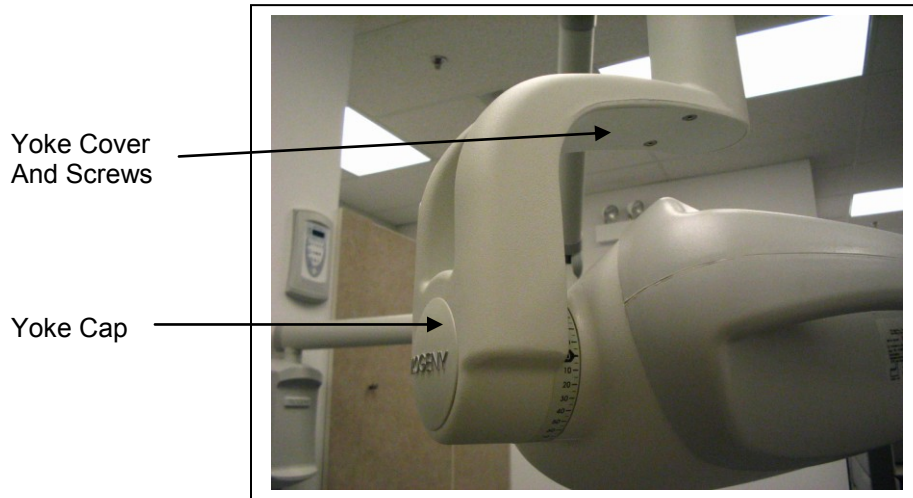
### Contact

Progeny - A Midmark Company  
675 Heathrow Dr.  
Lincolnshire, IL 60069  
Phone: 888-924-3800  
Fax: 847-415-9801

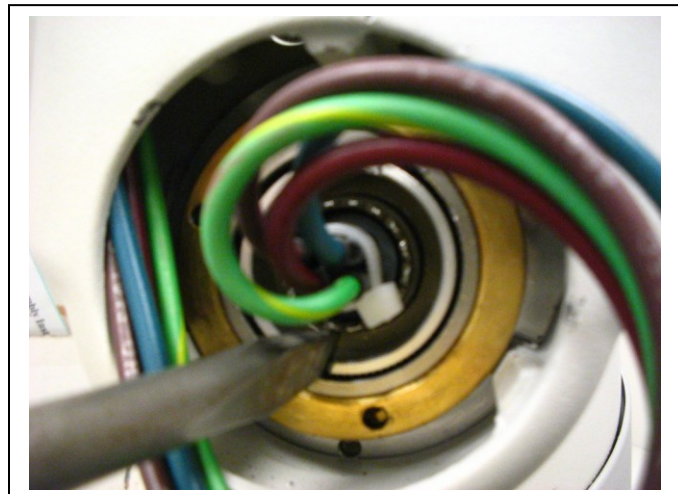
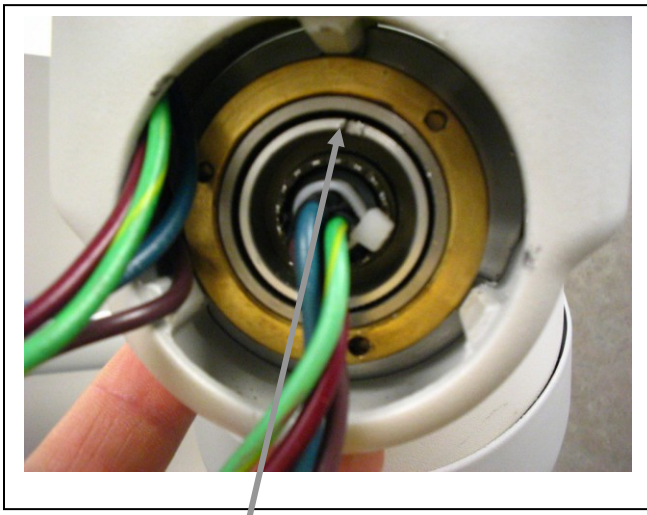
## JB70 Head and Harness Replacement

Tools required:  
 Screw drives – large flat blade and a #2 phillips  
 3/8" ratchet and extension  
 2.5mm and 3 mm allen wrenches  
 Long nose pliers and diagonal side cutters

Remove the yoke cap from the side and the cover from beneath the yoke arm. The cover is attached by two flat head allen screws.



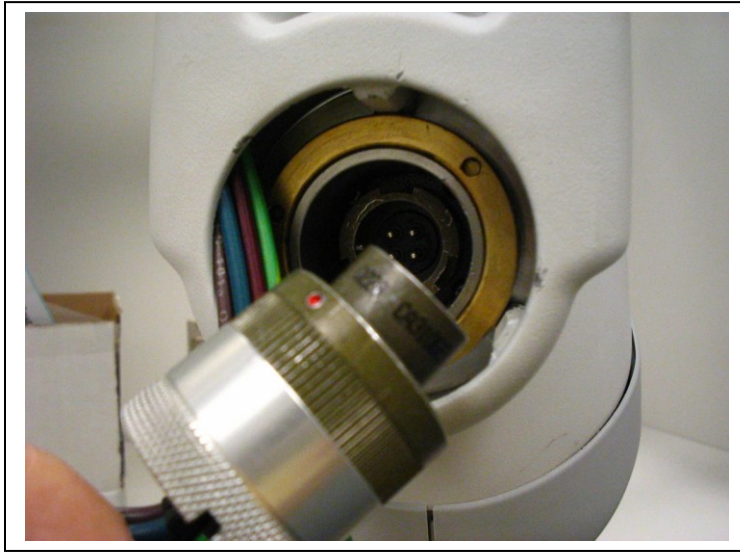
Remove the harness from the head using a large flat blade screw driver. Insert the screw driver in one of the slots provided in the plug nut at the tube. Twist and turn the screw drive counter-clockwise ¼ turn then pull the nut and harness away from the head.



Plug nut and slot



Unplug the harness from the articulating arm and discard.



Kit Contents

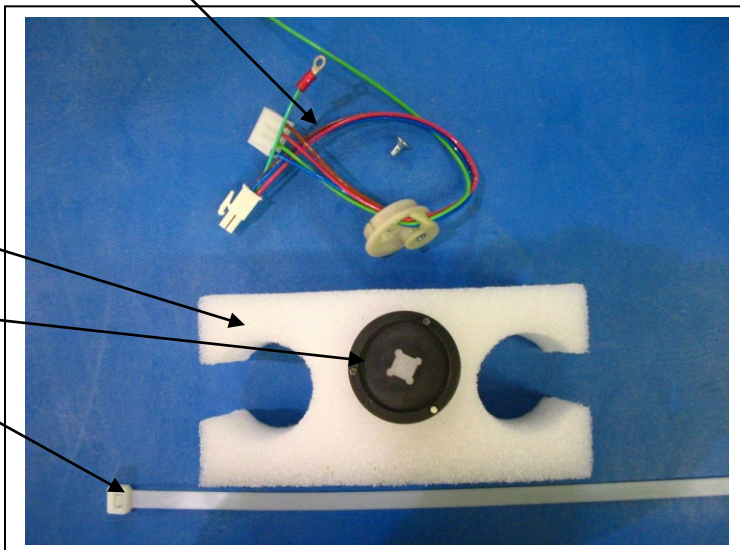
Instructions (not shown)

New harness, cam and screw

Foam block

Special tool

Ty-strap





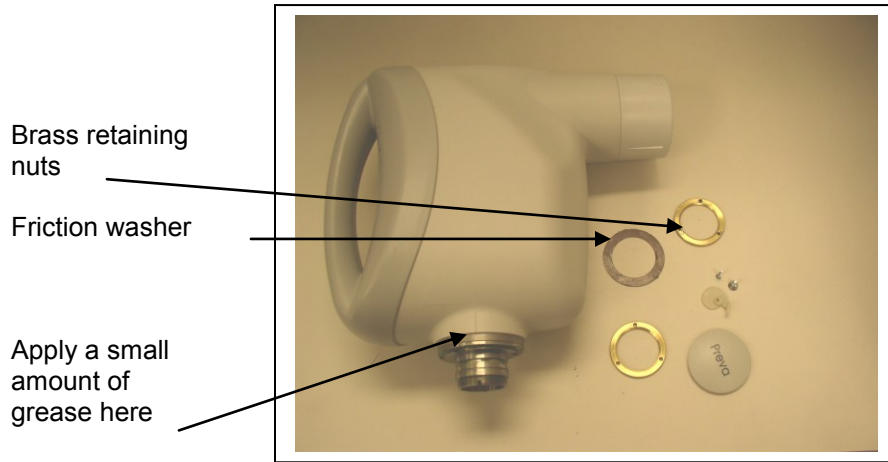
Close the articulated arm, using the foam block and try strap provided secure the arm in the closed position.



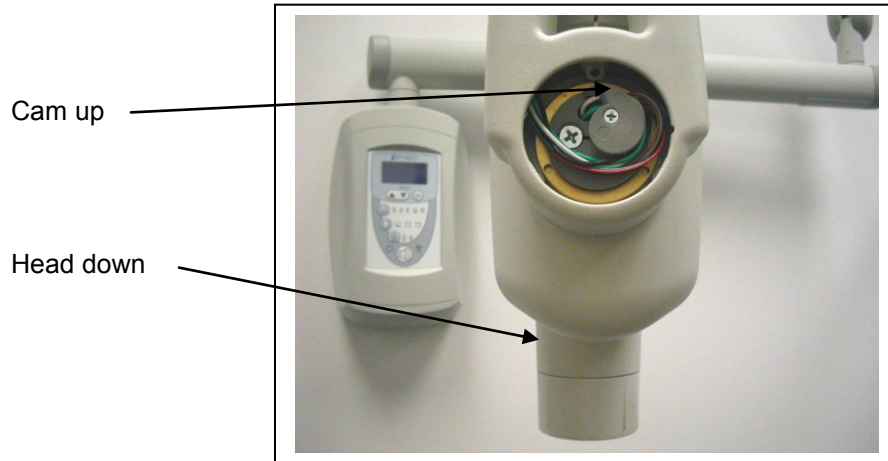
Remove the head from the articulated arm by loosening and removing both brass retaining nuts with the special tool 30-T0055. Pull the head away from the yoke to remove the head. Check the shaft of the head and the inside of the yoke for the friction washer; retain this washer for use when mounting the new head.



Apply grease to the shaft of the new head. Place the friction washer on the shaft and mount the head to the yoke. Re-install and tighten both brass nuts. Plug the new harness into the head and re-install the plastic cam harness. Replace the yoke cap.








Route the harness up through the yoke and plug it into the articulating arm harness. Replace the yoke cover using the screw previously removed.








## Setting Operator Panel Controls

### Power On Settings

When the JB-70 Dental X-Ray System is powered on, the Operator Panel selections are those that were in use when the system was last powered off.

| <b>Pre-programmed Exposure Times</b>  |                    |   |                  |                     |                  |                       |                  |
|---|--------------------|---|------------------|---------------------|------------------|-----------------------|------------------|
|   |                    | The table below shows the pre-programmed exposure times for each combination of Tooth, Image Receptor Type and Patient Size on the Operator Panel. These exposure times can be modified using the procedure that follows the table. |                  |                     |                  |                       |                  |
| <b>Times for 8 inch (20 cm) Cone in Seconds 60 Hz (50 Hz Times in Parenthesis)</b>  |                    |   |                  |                     |                  |                       |                  |
|   |                    | <b>Digital Receptor</b>   |                  | <b>D-speed Film</b> |                  | <b>E/F Speed Film</b> |                  |
| <b>Tooth Selection</b>  |                    | <b>Adult</b>  | <b>Child</b>     | <b>Adult</b>        | <b>Child</b>     | <b>Adult</b>          | <b>Child</b>     |
|  | <b>Incisor</b>     | 0.100<br>(0.120)  | 0.050<br>(0.060) | 0.300<br>(0.360)    | 0.150<br>(0.180) | 0.183<br>(0.220)      | 0.100<br>(0.120) |
|  | <b>Bicuspid</b>    | 0.133<br>(0.100)  | 0.067<br>(0.080) | 0.300<br>(0.360)    | 0.150<br>(0.180) | 0.183<br>(0.220)      | 0.100<br>(0.120) |
|  | <b>Bitewing</b>    | 0.100<br>(0.120)  | 0.050<br>(0.060) | 0.367<br>(0.440)    | 0.167<br>(0.200) | 0.200<br>(0.240)      | 0.117<br>(0.140) |
|  | <b>Lower Molar</b> | 0.100<br>(0.120)  | 0.050<br>(0.060) | 0.367<br>(0.440)    | 0.167<br>(0.200) | 0.200<br>(0.240)      | 0.117<br>(0.140) |
|  | <b>Upper Molar</b> | 0.167<br>(0.200)  | 0.083<br>(0.100) | 0.417<br>(0.500)    | 0.200<br>(0.240) | 0.233<br>(0.280)      | 0.133<br>(0.160) |

| Times for 12 inch (30 cm) Cone in Seconds 60 Hz (50 Hz Times in Parenthesis)        |                    |                  |                  |                  |                  |                  |                  |
|---|--------------------|------------------|------------------|------------------|------------------|------------------|------------------|
|   |                    | Digital Receptor |                  | D-speed Film     |                  | E/F Speed Film   |                  |
| Anatomy   |                    | Adult            | Child            | Adult            | Child            | Adult            | Child            |
|    | <b>Incisor</b>     | 0.233<br>(0.280) | 0.117<br>(0.140) | 0.600<br>(0.720) | 0.300<br>(0.360) | 0.367<br>(0.440) | 0.183<br>(0.220) |
|    | <b>Bicuspid</b>    | 0.300<br>(0.360) | 0.150<br>(0.180) | 0.600<br>(0.720) | 0.300<br>(0.360) | 0.367<br>(0.440) | 0.183<br>(0.220) |
|    | <b>Bitewing</b>    | 0.233<br>(0.280) | 0.117<br>(0.140) | 0.733<br>(0.880) | 0.333<br>(0.400) | 0.417<br>(0.500) | 0.200<br>(0.240) |
|    | <b>Lower Molar</b> | 0.233<br>(0.280) | 0.117<br>(0.140) | 0.733<br>(0.880) | 0.333<br>(0.400) | 0.417<br>(0.500) | 0.200<br>(0.240) |
|  | <b>Upper Molar</b> | 0.367<br>(0.440) | 0.183<br>(0.220) | 0.833<br>(1.00)  | 0.417<br>(0.500) | 0.467<br>(0.560) | 0.233<br>(0.280) |

1 impulse = 0.0167 sec = 16.7 ms (60 Hz)

1 impulse = 20.020 sec = 20 ms (50 Hz)

| impulses | = | time  |       | impulses | = | time  |       |
|----------|---|-------|-------|----------|---|-------|-------|
|          |   | 50Hz  | 60 Hz |          |   | 50Hz  | 60Hz  |
| 3        |   | 0.060 | 0.050 | 22       |   | 0.440 | 0.367 |
| 4        |   | 0.080 | 0.067 | 25       |   | 0.500 | 0.418 |
| 5        |   | 0.100 | 0.084 | 28       |   | 0.560 | 0.468 |
| 6        |   | 0.120 | 0.100 | 32       |   | 0.640 | 0.534 |
| 7        |   | 0.140 | 0.117 | 36       |   | 0.720 | 0.601 |
| 8        |   | 0.160 | 0.134 | 40       |   | 0.800 | 0.668 |
| 9        |   | 0.180 | 0.150 | 44       |   | 0.880 | 0.735 |
| 10       |   | 0.200 | 0.167 | 50       |   | 1.000 | 0.835 |
| 11       |   | 0.220 | 0.184 | 56       |   | 1.120 | 0.935 |
| 12       |   | 0.240 | 0.200 | 62       |   | 1.240 | 1.035 |
| 14       |   | 0.280 | 0.234 | 70       |   | 1.400 | 1.169 |
| 16       |   | 0.320 | 0.267 | 78       |   | 1.560 | 1.303 |
| 18       |   | 0.360 | 0.301 | 86       |   | 1.720 | 1.436 |
| 20       |   | 0.400 | 0.334 | 99       |   | 1.980 | 1.653 |

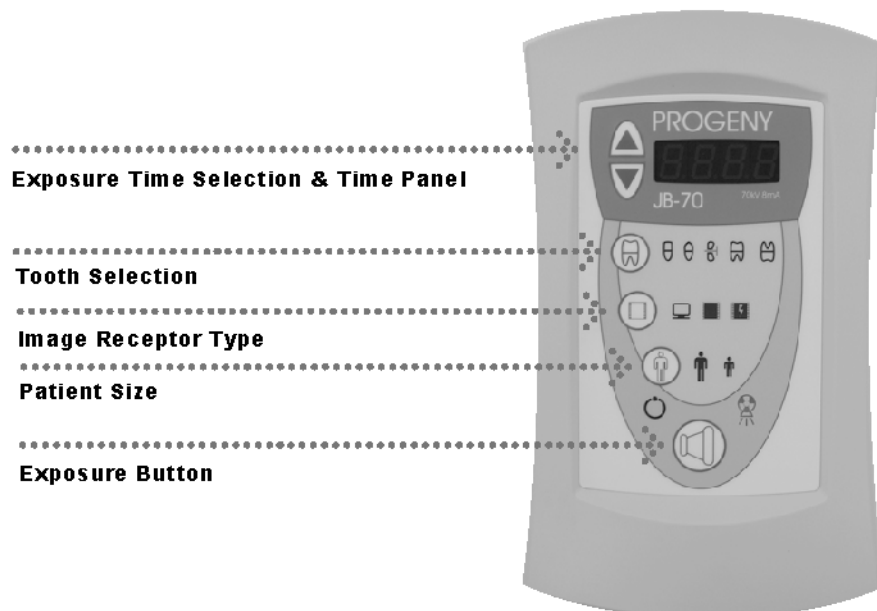
## Changing Programmed Exposure Times

The JB-70 Dental X-Ray System has a programming mode during which the exposure times can be modified.

**Note:** When the system is in programming mode, it ignores the x-ray exposure circuit such that when the Exposure button is pressed no x-ray is made. When in programming mode, pressing the Exposure button stores the current Operator Panel settings.

1. To enter programming mode, press and hold the Image Receptor Type, Tooth Type, or patient size buttons while turning ON the power. The Ready Indicator will flash to indicate that the system is in programming mode.
2. Select the combination of technique factors whose exposure time is to be changed.
  - a. Use the Image Receptor Type button to select the receptor type.
  - b. Use the Tooth Selection button to select a tooth.
  - c. Use the Patient Size button to select the patient size.
3. Use the Time Selection buttons to change the exposure time for the combination of tooth, image receptor type and patient size.
 

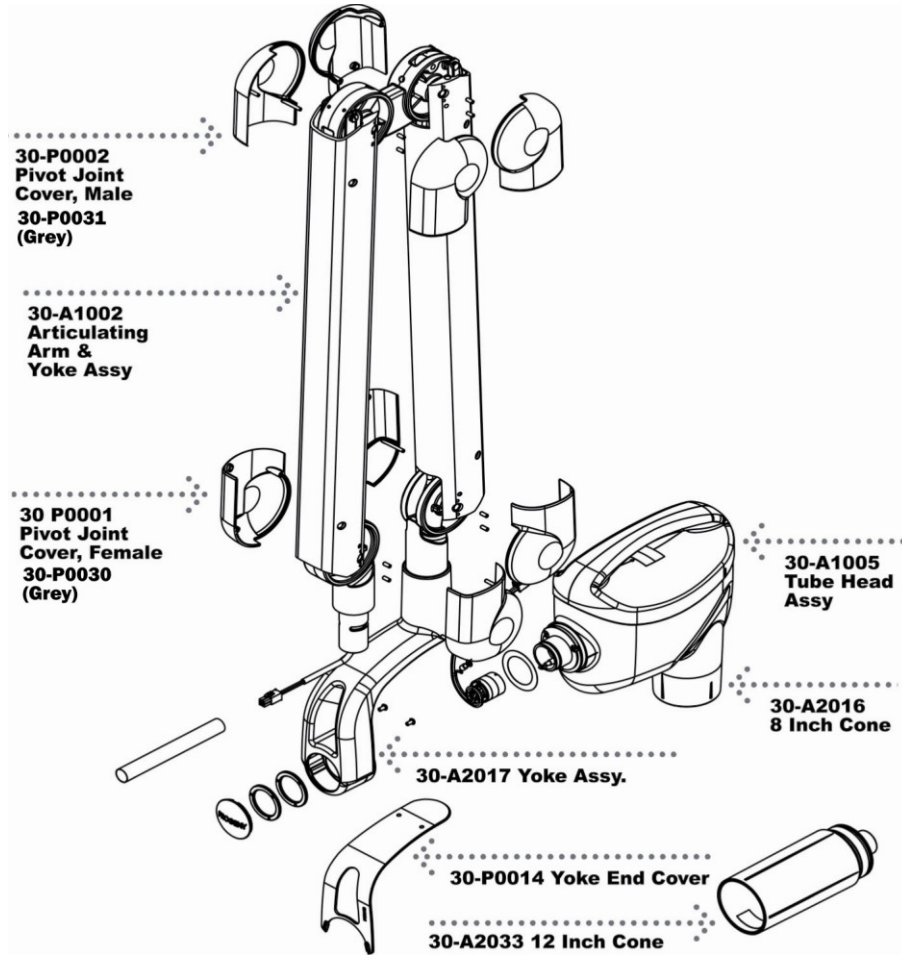
**Note:** When the Time Selection buttons are used, the Tooth Selection, Image Receptor Type and Patient Size buttons are turned off.
4. After the exposure times have been set, press the Exposure button to store the exposure times.
5. Repeat steps 2 and 4 until exposure times have been set for all combinations of image receptor, tooth and patient size.
6. When the exposure times have been stored, power off the system. To return the system to normal operational mode, power it on without holding any selection buttons.



**Figure 43**  
**Exposure Time**  
**Selection Buttons**

# Replacement Parts

## Arm and Tubehead



**Figure 44**  
**Arm and Tubehead**

**Spanner wrench 30-T0055**  
**Used to remove Tube Head retaining nuts.**

**Short cable (yoke) 30-08037**

# Horizontal Arm

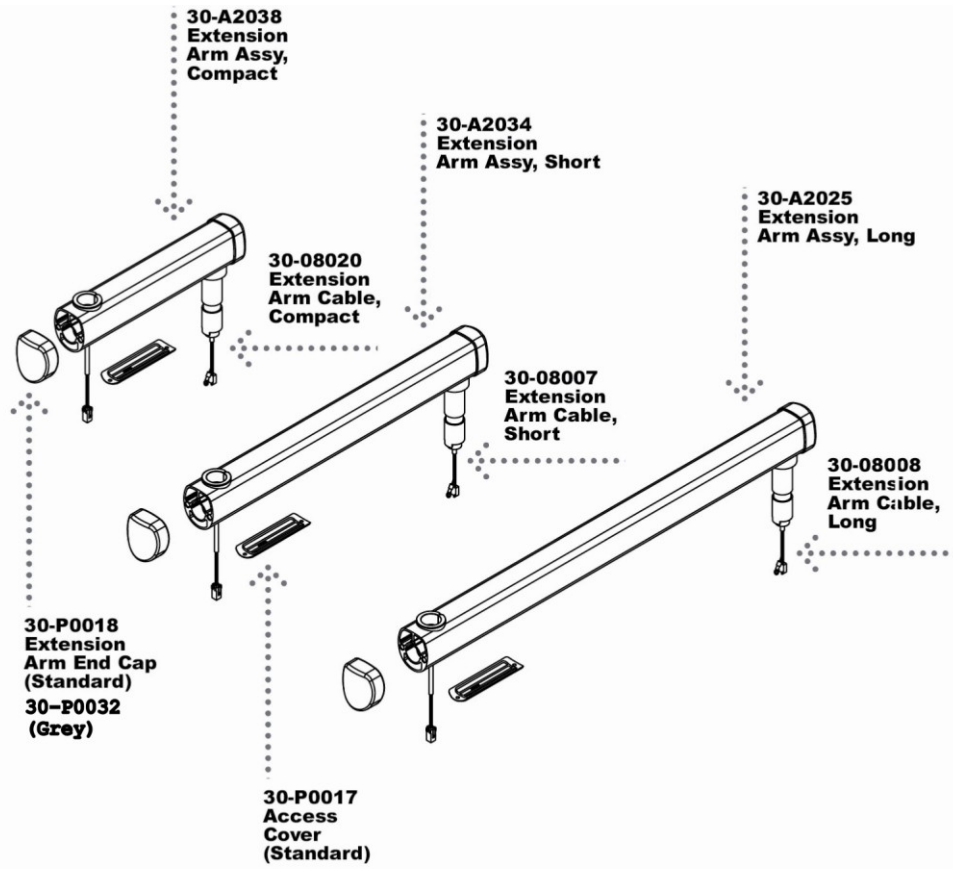


Figure 45  
Horizontal  
Arm

### Mounting Plates

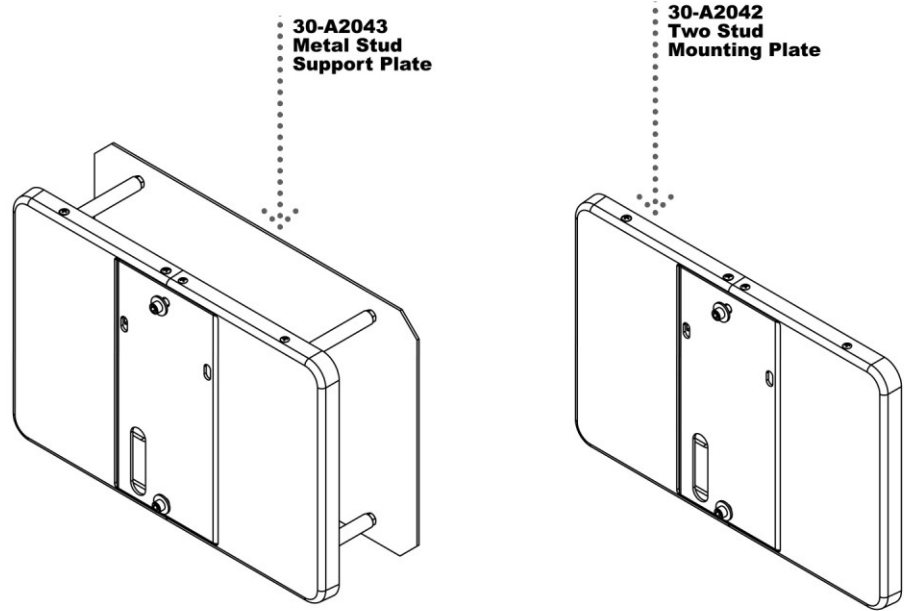


Figure 46  
Mounting Plates

### Operator Panel

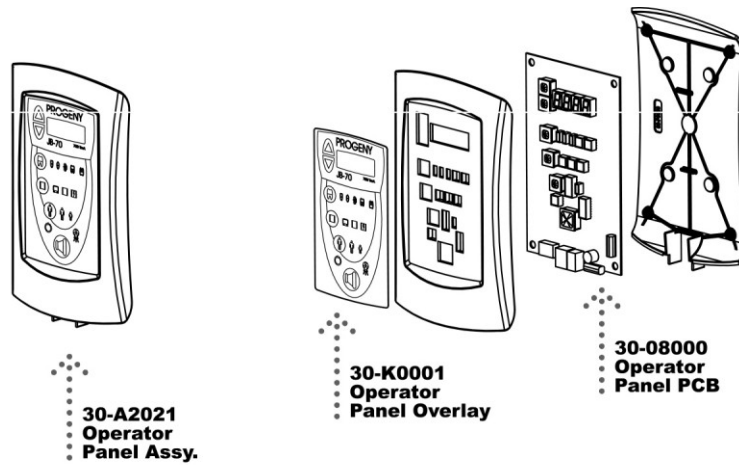


Figure 47  
Operator Panel



# Control Unit

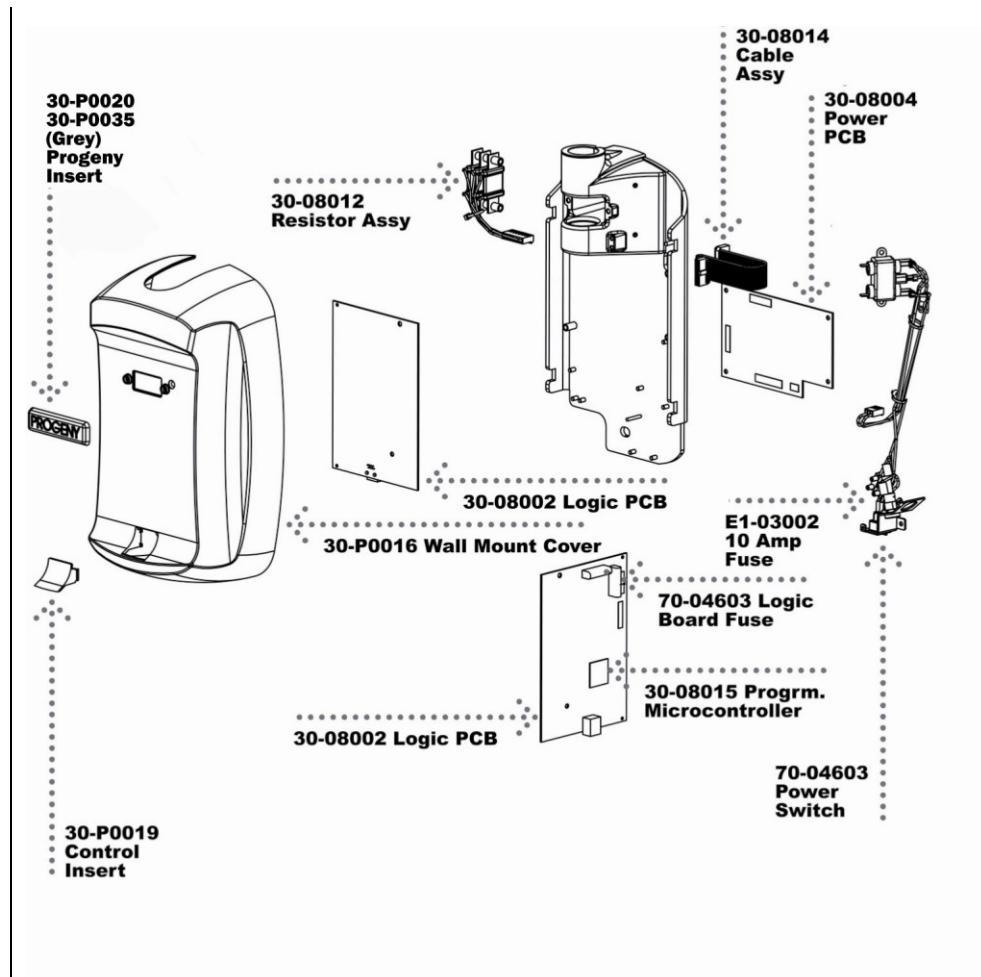


Figure 48  
Control Unit

# Hand Switch

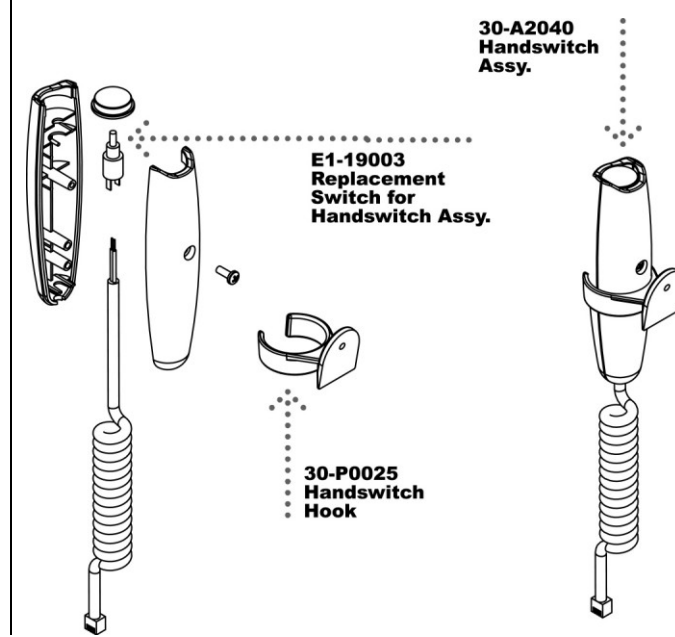


Figure 49  
Hand Switch

## Specifications

### JB-70 Dental X-Ray System

The following specifications contain information required to be provided to the user per Federal Regulation 21 CFR.

|  |   |
|--|---|
| <b>Line Voltage for Operation</b>                | 120 VAC +/- 10% 50/60 Hz  |
| <b>Line Load</b>                                 | 230 VAC +/- 10% 50/60 Hz  |
| <b>Maximum Rated Tube Potential kVp Accuracy</b> | Max. current 10 amps  |
| <b>Tube Current</b>                              | 70 KVp +/-10%   |
| <b>Exposure Time Selections</b>                  | 7 mA +/- 2 mA   |
| <b>Timer Accuracy</b>                            | 50 ms through 1.65 seconds for 60 Hz operation<br>60 ms through 2.0 seconds for 50 Hz operation.  |
| <b>Source to Skin Distance</b>                   | +/- 34 ms   |
| <b>Minimum Half Value Layer</b>                  | 8 inch (20 cm)<br>12 inch (30 cm)   |
| <b>Minimum Inherent Filtration</b>               | 1.7 mm Aluminum equivalent at 70 kVp  |
| <b>Focal Spot</b>                                | 2mm Aluminum equivalent @ 70 kVp  |
| <b>Automatic Cooling Time</b>                    | 0.7 mm (IEC 336)  |
| <b>Leakage Technique Factors</b>                 | 30 times the exposure time wait before the next exposure can begin  |
| <b>Target Angle</b>                              | 0.25 mA at 70 kVp   |
| <b>Operating Temperature</b>                     | 20 degrees  |
| <b>Storage Temperature</b>                       | +50 F/+113 F (+10 C/+45 C)  |
| <b>Maximum Altitude</b>                          | -31F/+150 F (-35 C/+66 C)   |
| <b>Cone Focal Length</b>                         | 12,000 ft   |
| <b>Diameter of X-Ray</b>                         | 8 inch(20 cm) for bisecting angle technique. Round and rectangular cone<br>12 inch(30 cm) for paralleling technique. . Round and rectangular cone |
|  | 2.7 inch (6.9 cm) at the end of the Cone  |

**Measurement Bias**

A filament warm up time of 0.217 seconds precedes each exposure. During this time, a very low level of radiation is produced. The peak tube potential varies during the filament warm up from approximately 60 kVp to 85 kVp. The amount of radiation produced during this time is very small and is not included in the kVp measurement or the exposure time measurement. The reason for this is that radiation meters will use the average peak kVp seen, even when extremely low amounts of radiation are produced. Also, the time for preheat to complete does not contribute to the time of radiation exposure.

For this reason, most non-invasive radiation meter manufacturers provide a dental measurement bias offset in a dental version of their instrument. For example, the Unfors 512 DENT, has a dental preheat bias offset of 5, 50, or 150 milliseconds. The 5 milliseconds setting is the default. Using the 150 msec offset, the trace amount of radiation produced at the beginning of preheat is ignored, resulting in accurate kVp measurement.

For time measurements using the Unfors 512 do not set an offset. After the exposure subtract 103 milliseconds from the overall time measurement.

Example:

Using the Unfors 512 DENT:

1. After power on, press the parameter key to display the kVp window. Press and hold the Parameter key for at least 4 seconds until the "d.5". Press the Parameter key one time to display "d.50". Press again to display "d.150". Press and hold the Parameter key until "0" is displayed. The 150 msec delay is now set. Then press the key to return to measurement mode. This will ignore 150 milliseconds of preheat.
2. Set the JB-70 exposure time on the control panel for 0.200. Make an exposure. Repeat to ensure consistency of measurement. Record the kVp reading from the meter.
3. For exposure times turn the Unfors 512 OFF then back ON, do not program an offset. Make several exposures to ensure consistency.

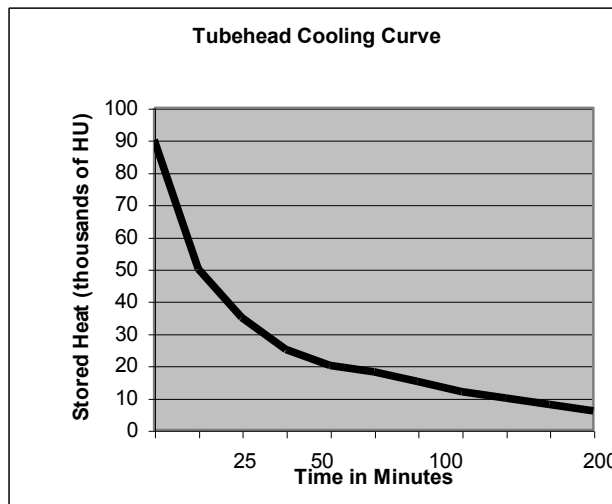
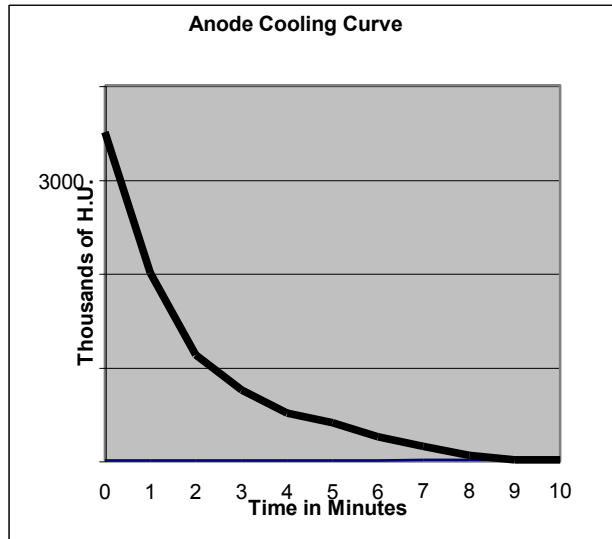
Time Display:  $0.303 - 0.103 = 0.200$ , the time to be recorded.

This is described in the Unfors manual under extended functions for kVp and time measurement.

Using the Radcal 4082:

See section labeled Dental Operation in the meter manual. Turn the meter on using the DENT button and scroll to threshold setting 5. Using this setting, the measurements should allow for preheat bias offset.

Tube Rating Charts



## Appendix A

### Assembly Instructions for JB-70 Mobile Unit

|   |   |
|---|---|
| <b>Tools</b>  | 3/8 square drive hex key 10 mm  |
| <b>Required</b>   | 3/8 square drive hex key x 6-inch extension   |
|   | 3/8 square drive ratchet  |
|   | No. 1 Phillips screwdriver  |
|   | 7 mm nut driver   |
|   | Small flat-blade screwdriver  |
|   | 4 mm hex key  |
|   | 5 mm hex key  |
|   | <b>Note:</b> It is recommended that 2 people assemble the unit.   |
|   | 1. Remove the five screws that hold the control cover. Carefully remove the cover.  |
|   | 2. Install the column into the base with the remote mount facing the control and install the special M12 socket cap screw into the hole under the control mounting plate and tighten. |
| 3. Loosen but <b>DO NOT REMOVE</b> the M6 button head screws that hold the bushing assembly into the column so that the arm assembly will not interfere with the screws during installation.  |   |
| 4. Plug the cable to the arm assembly, insert the arm assembly into the bushing, and gently pull the other end of the cable as you install the arm assembly.  |   |
| 5. With the Tubehead over the long legs, tighten the M6 button head screws.   |   |
| 6. Install the remote cradle and remote exposure button with the two M5 X 8 mm Phillips pan head screws. Route the remote cable through the rectangular hole and the remote exposure cable through the slot in the bottom of the cradle.  |   |
| 7. Remove the backing on the remote exposure holder and install the M3 X 12 mm Phillips pan head screw. Install on the back of the remote cradle on the left side and tighten the screw, ensuring the holder is straight.   |   |
| 8. Attach the remote cable to the remote, and install the remote to the cradle.   |   |
| 9. Attach the cable from the arm assembly to J1 on the power board, J4 on the Logic Board, and ground wire to the ground lug.   |   |
| 10. Attach the cable from the remote to J1 on the Logic Board.  |   |
| 11. Route both cables so that they do not interfere with installing the cover.  |   |
| 12. Attach the strain relief bracket diagonally across the studs on the chassis.  |   |
| 13. Route the power cord through the rubber grommet in the cover and through the strain relief bracket. Attach the black wire to L on the power block, the white wire to the N on the power block, and the ground wire to the ground lug. Install the Hayco into the strain relief. |   |
| 14. Plug in the power switch to the two connectors near the power block.  |   |
| 15. Reinstall the cover with the five M3 X 5 mm Phillips pan head screws and, tighten.  |   |
| 16. Install the Velcro strap around the pivot joint at the column and the loose ends around the pivot joint at the Tubehead.  |   |
| 17. Install handle on upper support bracket of the remote with two M6 X 20 mm socket head cap screws and M6 spring lock washer.   |   |

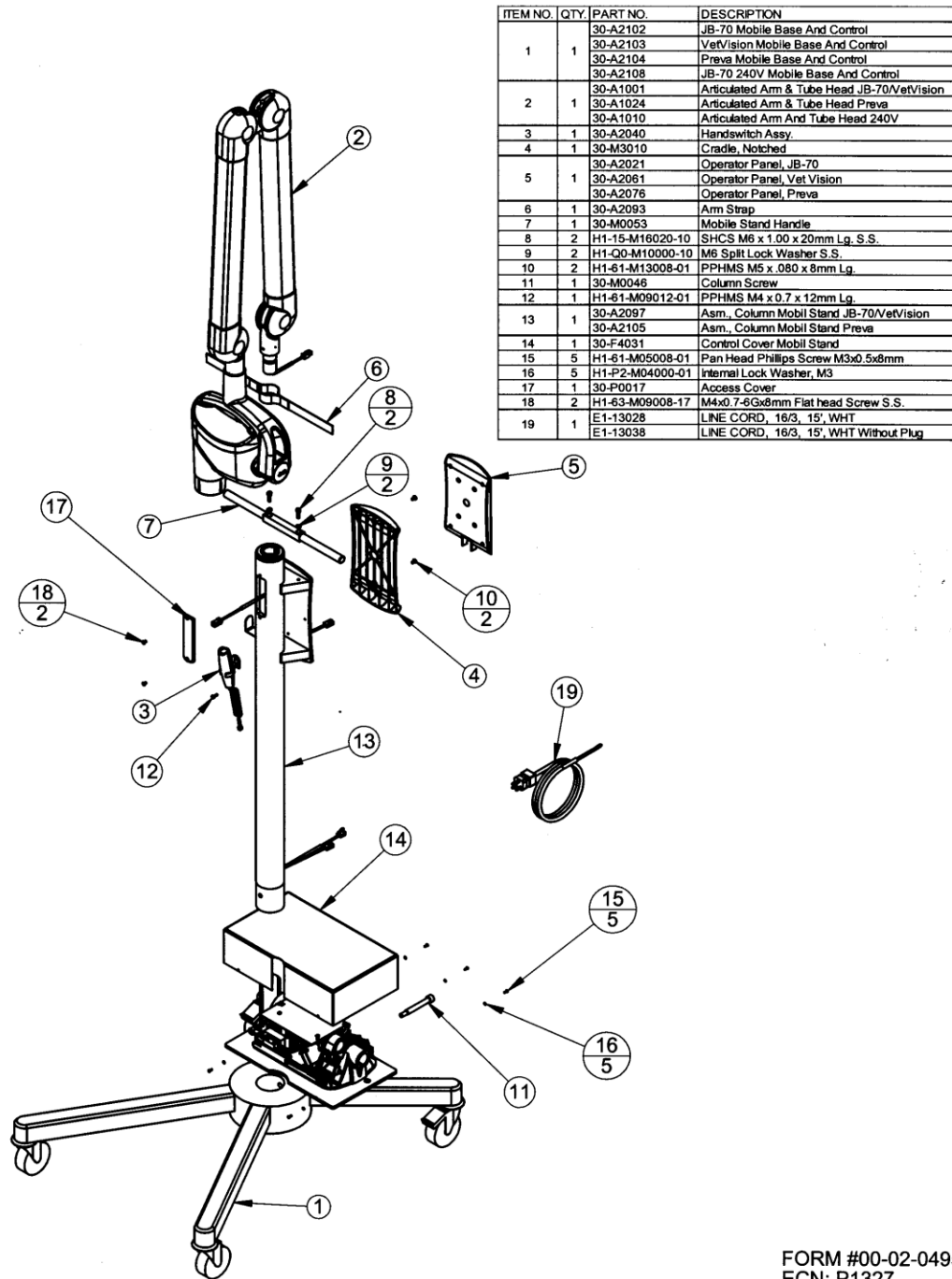


Figure 50  
Mobile Unit  
Assembly

FORM #00-02-0495  
ECN: P1327  
REV. B