

# MEITRACK MVT800 User Guide



## Change History

File Name	MEITRACK MVT800 User Guide	Created By	Renny Lee
Project	MVT800	Creation Date	2013-01-04
		Update Date	2015-08-20
Subproject	User Guide	Total Pages	17
Version	V2.1	Confidential	External Documentation

## Contents

1 Copyright and Disclaimer .....	- 4 -
2 Product Overview .....	- 4 -
3 Product Function and Specifications .....	- 4 -
3.1 Product Function .....	- 4 -
3.1.1 Position Tracking .....	- 4 -
3.1.2 Anti-Theft .....	- 4 -
3.1.3 Optional Accessory Function .....	- 5 -
3.1.4 Other Functions .....	- 5 -
3.2 Specifications .....	- 5 -
4 MVT800 and Accessories .....	- 6 -
5 Appearance .....	- 7 -
6 First Use .....	- 7 -
6.1 Installing the SIM Card .....	- 7 -
6.2 LED Indicator .....	- 8 -
6.3 Configured by Computer .....	- 8 -
6.4 Tracking by Mobile Phone .....	- 9 -
6.5 Common SMS Commands .....	- 10 -
6.5.1 Setting a Function Phone Number .....	- 10 -
6.5.2 Arming/Disarming .....	- 10 -
6.6 Advanced Settings .....	- 11 -
6.6.1 Setting the Vehicle Speed Coefficient Function .....	- 11 -
6.6.2 (Optional) Setting the RF Remote Control Code Matching Function .....	- 12 -
7 MS03 Tracking System .....	- 13 -
8 Installing the MVT800 .....	- 13 -
8.1 Installing GPS and GSM Antennas .....	- 13 -
8.2 Installing an I/O Cable .....	- 14 -
8.2.1 Port Definition .....	- 14 -
8.2.2 Port Pictures .....	- 14 -
8.2.3 Power Cable/Ground Wire .....	- 15 -
8.2.4 Level Detection Port .....	- 15 -
8.2.5 ACC and Door Detection .....	- 15 -
8.2.6 Signal Detection .....	- 16 -
8.2.7 Remote Fuel and Power Cut-off .....	- 16 -
8.2.8 (Optional) Buzzer .....	- 16 -
8.2.9 (Optional) Temperature and Fuel Detection Ports .....	- 16 -
8.2.10 (Optional) Loudspeaker and Microphone Ports .....	- 17 -
8.3 Mounting the MVT800 .....	- 17 -

## 1 Copyright and Disclaimer

Copyright © 2015 MEITRACK. All rights reserved.

 and  are trademarks that belong to Meitrack Group.

The user manual may be changed without notice.

Without prior written consent of Meitrack Group, this user manual, or any part thereof, may not be reproduced for any purpose whatsoever, or transmitted in any form, either electronically or mechanically, including photocopying and recording.

Meitrack Group shall not be liable for direct, indirect, special, incidental, or consequential damages (including but not limited to economic losses, personal injuries, and loss of assets and property) caused by the use, inability, or illegality to use the product or documentation.

## 2 Product Overview

The MVT800 is a brand new GPS tracker specially designed for private and commercial vehicles. The tracker can be used as an alarm device to implement the anti-theft function. It also has powerful features: remote arming and disarming by pressing a button and IP65 water resistant and dust-proof level.

## 3 Product Function and Specifications

### 3.1 Product Function

#### 3.1.1 Position Tracking

- GPS + GSM dual-module tracking
- Real-time location query
- Track by time interval
- Track by distance
- Track by mobile phone
- Speeding alarm
- Direction change alarm

#### 3.1.2 Anti-Theft

- SOS alarm
- GPS antenna cut-off alarm
- External power supply cut-off alarm
- GPS blind spot alarm
- Low power alarm
- Remote vehicle fuel/power cut-off alarm
- Towing alarm
- Arming/Disarming
- Engine or vehicle door status alarm
- Geo-fence

### 3.1.3 Optional Accessory Function

Accessory	Function
Loudspeaker and microphone	Listen-in or two-way calling
Buzzer	Report alarms.
Fuel analog detection input	High and low fuel alarms
Digital temperature sensor detection input	High and low temperature alarms
Wireless remote control	Remote arming and disarming by pressing a button
RF antenna	Enlarge the wireless remote control distance.

### 3.1.4 Other Functions

- Meitrack SMS/GPRS (TCP/UDP) protocol
- Built-in 8 MB buffer for recording driving routes
- Smart power-saving mode
- Mileage report
- Built-in 850 mAh standby battery
- Water resistant (IP65)
- One output and four digital inputs (one negative input, one positive input, and two inputs that can be flexibly configured by using software)
- Speed frequency check
- Support Over-the-Air (OTA)

### 3.2 Specifications

Item	Specifications
Dimension	90 mm x 65 mm x 32 mm
Weight	220g
Input voltage	DC 11 V to 36 V/1.5 A
Standby battery	850 mAh/3.7 V
Power consumption	85 mA standby current
Operating temperature	-20°C to 55°C
Humidity	5% to 95%
Working hour	36 hours in power-saving mode and 8 hours in normal mode
LED indicator	2 indicators showing GSM and GPS status
Button/Switch	1 SOS button (for sending SMSs or dialing) 1 power button
Microphone/Loudspeaker	(optional) External
Memory	8 MB byte
Sensor	3D acceleration sensor (for wake-up by vibration and towing alarms)
GSM frequency band	GSM 850/900/1800/1900 MHz
GPS sensitivity	-161 dB
Positioning accuracy	10m
GSM/GPS antenna	Connected to the SMA connector

I/O port	4 inputs (1 SOS button, 1 smart positive/negative input, 1 door triggering, and 1 ACC detection) 1 speed sensor frequency detection 2 outputs (1 buzzer and 1 remote fuel cut-off cable) 1 analog detection input 1 digital temperature sensor detection input 1 USB232 configuration port 1 wireless remote control (433 Mhz) port
----------	---

## 4 MVT800 and Accessories

MVT800 and standard accessories:



MVT800 with a built-in battery



GPS antenna



GSM antenna



I/O cable



Power extension cord



SOS button



USB cable



CD

Optional accessories:



Wireless remote control



Buzzer



Microphone



Loudspeaker



Fuel sensor



Temperature sensor



RF antenna

## 5 Appearance

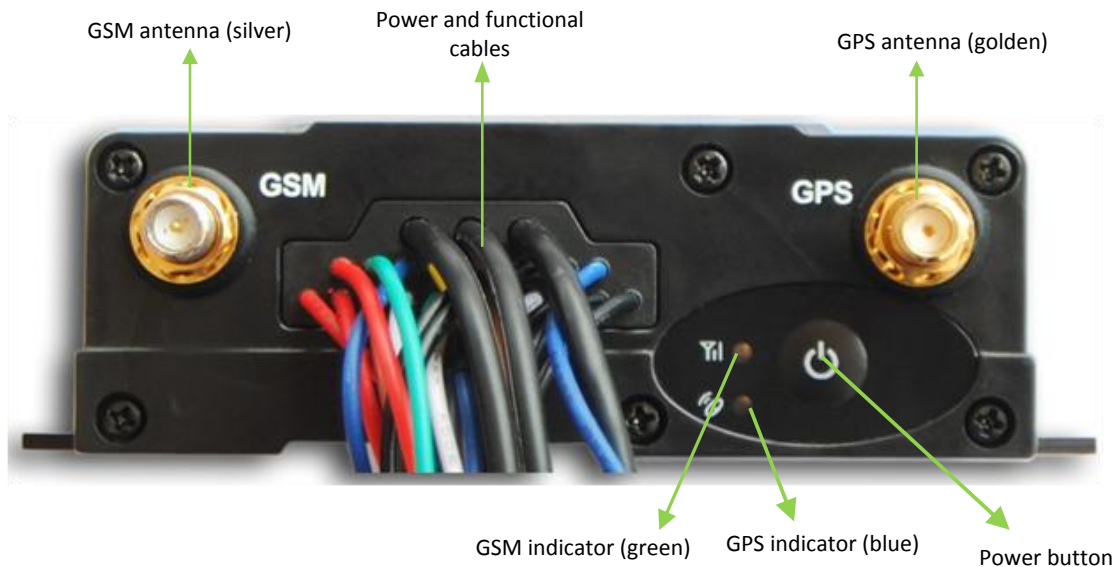

## 6 First Use

### 6.1 Installing the SIM Card

To install the SIM card, perform the following operations:

1. Loosen the screw, and remove the cover.
2. Insert the SIM card into the card slot with its gold-plated contacts facing towards the Printed Circuit Board (PCB).
3. Close the cover, and tighten the screw.

Note:

- Ensure that the SIM card has sufficient balance.
- Ensure that the phone card PIN lock has been closed properly.
- Ensure that the SIM card in the MVT800 has subscribed the caller ID service if you want to use your authorized phone number to dial the MVT800.
- Power off the MVT800 before installing the SIM card.





## 6.2 LED Indicator

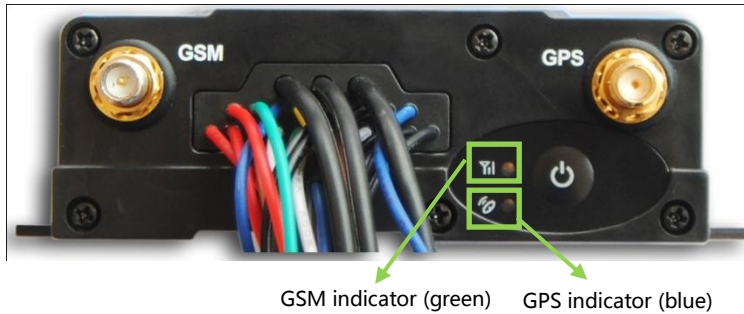

To start the MVT800, press and hold down the power button for 3s to 5s, or connect the MVT800 to external power supply.

GPS Indicator (Blue)	
Steady on	One button is pressed or one input is activated.
Blink (every 0.1s)	The MVT800 is being initialized or the battery power is low.
Blink (0.1s on and 2.9s off)	A GPS signal is received.
Blink (1s on and 2s off)	No GPS signal is received.
GSM Indicator (Green)	
Steady on	A call is coming in or busy.
Blink (every 0.1s)	The MVT800 is being initialized.
Blink (0.1s on and 2.9s off)	A GSM signal is received.
Blink (1s on and 2s off)	No GSM signal is received.

## 6.3 Configured by Computer

This section describes how to use MEITRACK Manager to configure the MVT800 on a computer.

Procedure:

1. Install the USB driver and Meitrack Manager.
2. Connect the MVT800 to a PC by using a USB cable.



3. Run Meitrack Manager. The following dialog box is displayed:





Meitrack Manager will automatically detect the device, and the **Device** tab page for default parameters is displayed. For details about Meitrack Manager, see the *MEITRACK Manager User Guide*.

### 6.4 Tracking by Mobile Phone

Call or send the **0000,A00** command by SMS to the MVT800 SIM card number. The device will reply an SMS with a map link. Click the SMS link. The location will be displayed on Google Maps on your mobile phone.

Note: Ensure that the MVT800 SIM card number has subscribed the caller ID service. Otherwise, you cannot call the device.



SMS example:

Now,110727 02:48,V,16,23Km/h,61%,http://maps.google.com/maps?f=q&hl=en&q=22.540103,114.082329

The following table describes the SMS format:

Parameter	Description	Remarks
Now	Indicates the current location.	SMS header: indicates the alarm type.
110727 02:48	Indicates the date and time in <b>YYMMDD hh:mm</b> format.	None
V	The GPS is invalid.	A = Valid V = Invalid
16	Indicates the GSM signal strength.	Value: 1–32 The larger the value is, the stronger the signal is. If the value is greater than 12, GPRS reaches the normal level.
23Km/h	Indicates the speed.	Unit: km/h
61%	Indicates the remaining battery power.	None
http://maps.google.com/maps?f=q&hl=en&q=22.540103,114.082329	This is a map link. Latitude: 22.540103 Longitude: 114.082329	None

If your mobile phone does not support HTTP, enter the latitude and longitude on Google Maps to query a location.

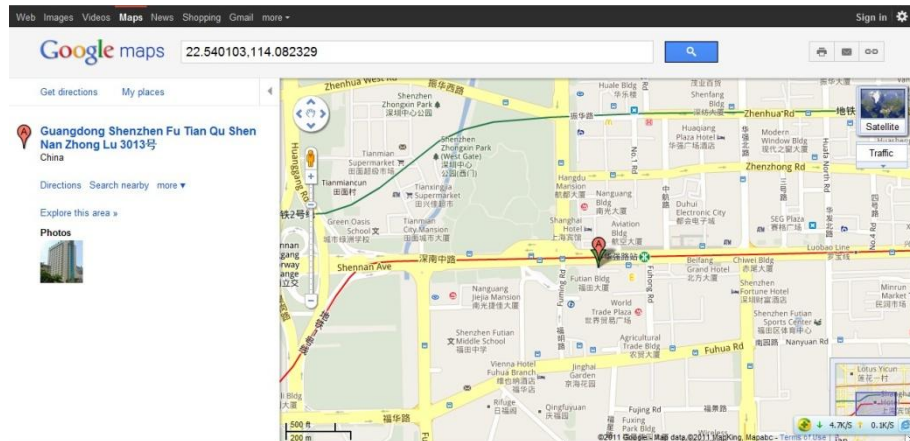

## 6.5 Common SMS Commands

### 6.5.1 Setting a Function Phone Number

SMS sending: 0000,A71,Phone number 1,Phone number 2,Phone number 3

SMS Responding: IMEI,A71,OK

Description:

Phone number: A function phone number has a maximum of 16 bytes. If no phone numbers are set, leave them blank. Phone numbers are empty by default.

Phone number 1/2/3: Set phone number 1/2/3 to the SOS phone number. When you call the tracker by using the phone number, SMSs of locations, geo-fence alarms, and low power alarms are received, and calls and SMSs of unauthorized door opening and ignition are received.

If all function phone numbers need to be deleted, send **0000,A71**.

When the SOS button is pressed, the tracker dials phone numbers 1, 2, and 3 in sequence. The tracker stops dialing when a phone number responds.

Example: 0000,A71,13811111111,13822222222,13833333333

Responding: 353358017784062,A71,OK

### 6.5.2 Arming/Disarming

A wireless remote control or SMS command can be used to set the anti-theft function.

You are advised to use a wireless remote control and buzzer to strengthen protection. Set an authorized phone number to ensure that SMSs and calls can be received when a vehicle is stolen.

- Set by wireless remote control: Press the **Lock** key on the remote control to enter the arming state. If a buzzer is installed and makes a sound, arming is implemented successfully. If no buzzer is installed, check whether the preset phone number receives a call or an SMS. Press **Unlock** to enter the disarming state. (For details about code matching of the remote control, see the section 6.6.2 "(Optional) Setting the RF Remote Control Code Matching Function.")
- Set by SMS command: Set arming or disarming by SMS command.

SMS command: 0000,B21,Status

Response: IMEI,B21,OK

Note:

- When **Status** is **1**, enable the arming function. In arming state, opening the vehicle door and starting the ACC are

unauthorized operations. If these operations are performed, the tracker will send an alarm SMS and make a call to the preset authorized phone number.

- When **Status** is **0**, disable the arming function. In disarming state, all anti-theft alarms will be cleared.

Function	Call	SMS	Engine Cut	Buzzer	Remarks
Opening the vehicle door	√	√		√	When the vehicle door is opened without permission, the buzzer does not make sounds until the anti-theft state is cancelled. The tracker will dial three authorized phone numbers in sequence and send SMSs.
Starting the engine	√	√	√	√	When the engine is started, the engine will be cut off, and the buzzer does not make sounds until the anti-theft state is cancelled. The tracker will dial three authorized phone numbers in sequence and send SMSs.
Setting arming while driving (Intercepting the driving vehicle )		√	√		When the vehicle is stolen and driving, you can run GPRS or SMS commands only to intercept the driving vehicle. When the vehicle speed is lower than 5 km/h, the engine is cut off, and the tracker sends alarms to authorized phone numbers.
Towing alarm	√	√			When the ACC is off and the vehicle vibrates continuously, a towing alarm is generated. The tracker will dial three authorized phone numbers in sequence and send SMSs.

For details about SMS commands, see the *MEITRACK SMS Protocol*.

Note:

1. The default SMS command password is **0000**. You can change the password by using Meitrack Manager and SMS commands.
2. The device can be configured by SMS commands with a correct password. After an authorized phone number is set, only the authorized phone number can receive the preset SMS event report.

## 6.6 Advanced Settings

### 6.6.1 Setting the Vehicle Speed Coefficient Function

Connect tracker input 5 to the vehicle speed sensor, and set the vehicle speed coefficient to calibrate the vehicle speed. After the calibration is successful, calculate the vehicle speed and mileage based on the vehicle speed coefficient. The following two methods are used to set the function:

1. **Automatically calibrate the vehicle speed coefficient.**
  - a) The vehicle has been driving for 60s when the GPS speed is greater than 60 km/h.
  - b) The tracker has recorded the number of sensor pulses within 60s.
  - c) No sound prompt
  - d) The calibration cannot be performed if there is no pulse.
2. **Manually calibrate the vehicle speed coefficient.**
  - a) Send SMS or GPRS command B23 to enter the calibration state. After the tracker receives the command, the buzzer will make a long sound, and the green indicator is steady on.

**SMS command:** 0000,B23,Status

**Description:** When **Status** is **1**, enter the calibration state. The SMS command is **0000,B23,1**.

When **Status** is **0**, exit the calibration state.

**Response:** 0000,B23,OK

- b) When the vehicle is driven at the speed of 40 km/h, press the SOS button over 2s, the tracker starts to count the number of pulses within 2s. After the calibration is performed successfully, the buzzer makes two short sounds and then two long sounds. The green indicator recovers to the normal state.
- c) The current calibration value will be saved automatically after the calibration is performed successfully. In other words, the vehicle speed detected by the tracker will not be calibrated by using GPS positioning.
- d) When the tracker enters the calibration state and you do not press the SOS button five minutes after timeout, the tracker exits the calibration state.

## 6.6.2 (Optional) Setting the RF Remote Control Code Matching Function

If the remote control does not match the tracker, match the code manually. To identify code matching status, a buzzer needs to be used together with the remote control and tracker. There are the following two code matching modes:

### 1. ACC code matching mode

The code matching method can be used when input 4 is connected to the ACC. Perform the following operations to match the code:

- a) Turn 8 times from ACC OFF to ACC ON, and stay on the ACC ON state.
- b) After 3s, the buzzer makes two short sounds and then one long sound. It indicates that the tracker enters the code matching state. Meanwhile, the tracker green indicator is steady on.
- c) During the code matching state, press any key of the remote control to be matched within 20s. If the buzzer makes two sounds, the code is matched successfully. If you want to match another remote control, the operations are the same as that of the first remote control.
- d) When only one remote control needs code matching and no operations will be performed later, the system automatically exits the code matching mode 20s after the code is matched successfully.

Note:

- The interval between two times of ACC ON states cannot exceed 3s. Otherwise, the conversion times will be cleared.
- Complete the code matching within 20s. Otherwise, the system automatically exits the code matching state.
- After the code of one remote control is matched successfully, press a key on the remote control, and then the code matching mode exits.

### 2. Command code matching mode

- a) **SMS command:** 0000,B24,*Status*

**Description:** When **Status** is **1**, enter the code matching state. The SMS command is **0000,B24,1**.

When **Status** is **0**, exit the code matching state.

**Response:** 0000,B24,OK

- b) After the code matching mode is entered, operations are the same as that of the ACC code matching method.

### Defining RF Remote Control Keys

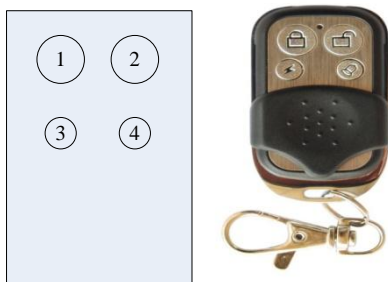

- Key 1: Press the key, the arming state is enabled, and then the buzzer will make a sound.
- Key 2: Press the key, the arming state is disabled, and then the buzzer will make two sounds.
- Key 3: Press and hold down the key for over 2s, and then an SMS or a GPRS alarm is generated (same as the function of the SOS button). When you dial the authorized phone number, the tracker automatically enters the silent listen-in state, and the buzzer and loudspeaker make no sound.
- Key 4: Press the key to look for a vehicle. Then, the buzzer will make five sounds.

Note: For details about how to enable the anti-theft function, see section 6.5.2 "Arming/Disarming."

## 7 MS03 Tracking System

Visit <http://ms03.meiligao.com>, enter the user name and password, and log in to the MS03. (Purchase the login account from your provider.)

For more information about how to add a tracker, see the *MEITRACK GPS Tracking System MS03 User Guide* (chapter 4 "Getting Started").

**The MS03 supports the following functions:**

- Track by time interval or distance.
- Query historical traces.
- Set polygon geo-fences.
- Bind driver and vehicle information.
- View various reports.
- Send commands in batches.
- Support OTA updates.

For details, see the *MEITRACK GPS Tracking System MS03 User Guide*.

## 8 Installing the MVT800

### 8.1 Installing GPS and GSM Antennas



Connect the GSM antenna to the connector which is labeled "GSM". The GSM antenna is non-directional, so you can hide it in any place of a vehicle.

Connect the GPS antenna to the connector which is labeled "GPS". It is recommended that the antenna should face up to the sky and the antenna side with words should face downwards. Secure the antenna by using double sided tapes.

Note: Do not install the GPS antenna at a place with metals.

## 8.2 Installing an I/O Cable

### 8.2.1 Port Definition

The I/O cable includes the power cable, analog input, positive and negative input, and output.

Port	Color	Description
Digital input 1 (SOS)	Input: white Ground wire: black	An alarm is generated when input 1 is triggered (or the SOS button is pressed).
Digital input 2	White	Input 2 can be a high or low level input. It is a low level input by default for door detection.
Digital input 3 (door)	Grey	Input 3 can be a high or low level input. It is a high level input by default for door detection.
Digital input 4 (ACC)	Brown	High level input (3 V to 60 V) Used for ACC detection by default.
Digital input 5 (RPM)	Green	Detect the speed sensor signal cable.
Digital output	Yellow	Open drain output Output power: 1 W 0 V to 100 V
Ground wire	Black	Ground wire
Power	Positive power cable: red Ground wire: black	Tracker main power DC 11 V to 36 V Undervoltage/Overvoltage protection
Buzzer output (PWM)	Output: brown Output: white	Buzzer plug: connects to the buzzer. The positive power cable is brown, and the ground wire is white.
Fuel AD detection port	Positive power cable: red Ground wire: black AD cable: blue	AD detection: 0 V to 5 V The output positive power voltage is the tracker input voltage The port must match the existing fuel sensor.
Temperature detection port	Positive power cable: red Ground wire: black USB cable: green	The positive power voltage is the tracker output voltage (5 V). The port must match the existing temperature sensor.
Microphone and loudspeaker	Green and red	The loudspeaker cable is green. The microphone cable is red.
Remote control antenna	Black	None

### 8.2.2 Port Pictures



Digital input 1 (SOS)



Buzzer plug



Temperature detection port



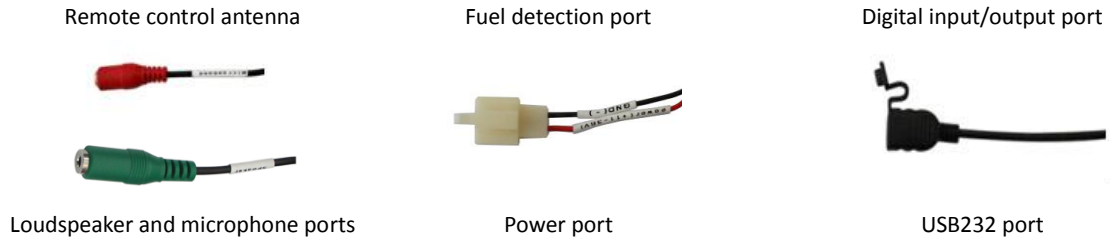

### 8.2.3 Power Cable/Ground Wire

Connect the power cable (red) and ground wire (black) to the positive and negative electrodes of the vehicle battery respectively.

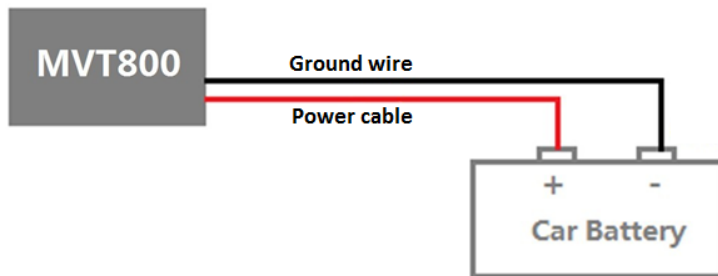

### 8.2.4 Level Detection Port



### 8.2.5 ACC and Door Detection

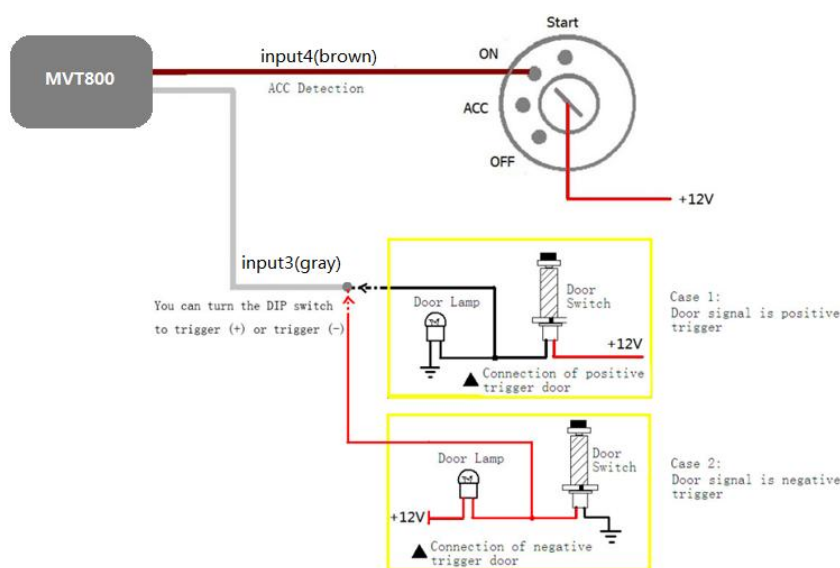

### 8.2.6 Signal Detection

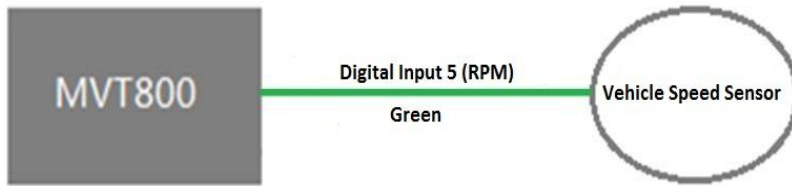

### 8.2.7 Remote Fuel and Power Cut-off

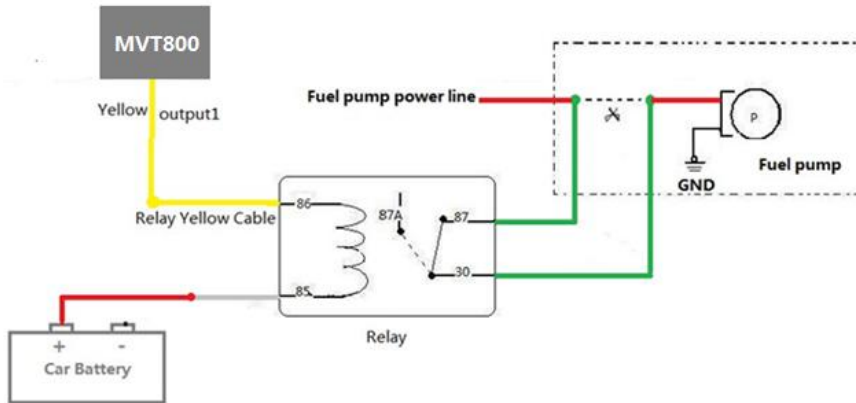

### 8.2.8 (Optional) Buzzer



### 8.2.9 (Optional) Temperature and Fuel Detection Ports

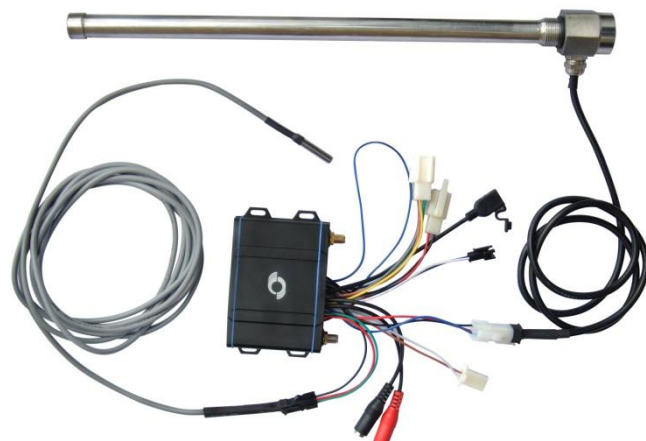



Note: For details about how to install and use the temperature and fuel sensors, see the *MEITRACK Temperature Sensor User Guide* and *MEITRACKER Fuel Sensor User Guide*.

### 8.2.10 (Optional) Loudspeaker and Microphone Ports



## 8.3 Mounting the MVT800

Tighten the four screws shown in the following figure.



If you have any questions, do not hesitate to email us at [info@meitrack.com](mailto:info@meitrack.com).