

Installation and Setting-Up Instructions

Contents:

1. INSTALLATION	
1.1 Mounting location	s. 2
1.2 Installing the transmitter	s. 3
1.3 Dimensions of the transmitter	s. 5
1.4 Electrical connections	
s. 6	
2 SETTING-UP	
2.1 Setting-up with Satron VoAdvisor Service Software	s. 8
2.2 Setting-up with local switches	s. 8
2.3 Setting-up with remote unit	s. 9
3 USER GUIDE FOR MENUS	
3.1 Configuration	s. 10
3.2 New sample	s. 12
3.3 Calibration	s. 12
3.4 Diagnostics	s. 13
4 SETTINGS	
4.1 Basic settings	s. 15
4.2 Collect sample	s. 15
4.3 Laboratory values	s. 15
4.4 Start-Up calibration	s. 16
4.5 1-point calibration	s. 16
4.6 2-point calibration	s. 16
4.7 Offset adjustment	s. 17
4.8 Gain adjustment	s. 17
4.9 Time and Date settings	s. 17



DOCUMENTS

Technical Specifications: BCs220

Installation and Setting-Up Instructions: BCs220AV

We reserve the right for technical modifications without prior notice.
HART® is the registered trademark of Hart Communication Foundation.
Hastelloy® is the registered trademark of Haynes International.
Teflon® E.I. is the registered trademark du Pont de Nemours & Co.
Viton® is the registered trademark DuPont Down Elastomer.



Satron Instruments Inc.

P.O.Box 22, FI-33901 Tampere, Finland

Tel. +358 207 464 800, Telefax +358 207 464 801

www.satron.com, info@satron.com

1. INSTALLATION

1.1 Mounting location

Installation recommendations: Figure 1-1

- transmitters should be installed as a general rule turbulence flow.
- Recommended installation location ①
- An alternative mounting location ②

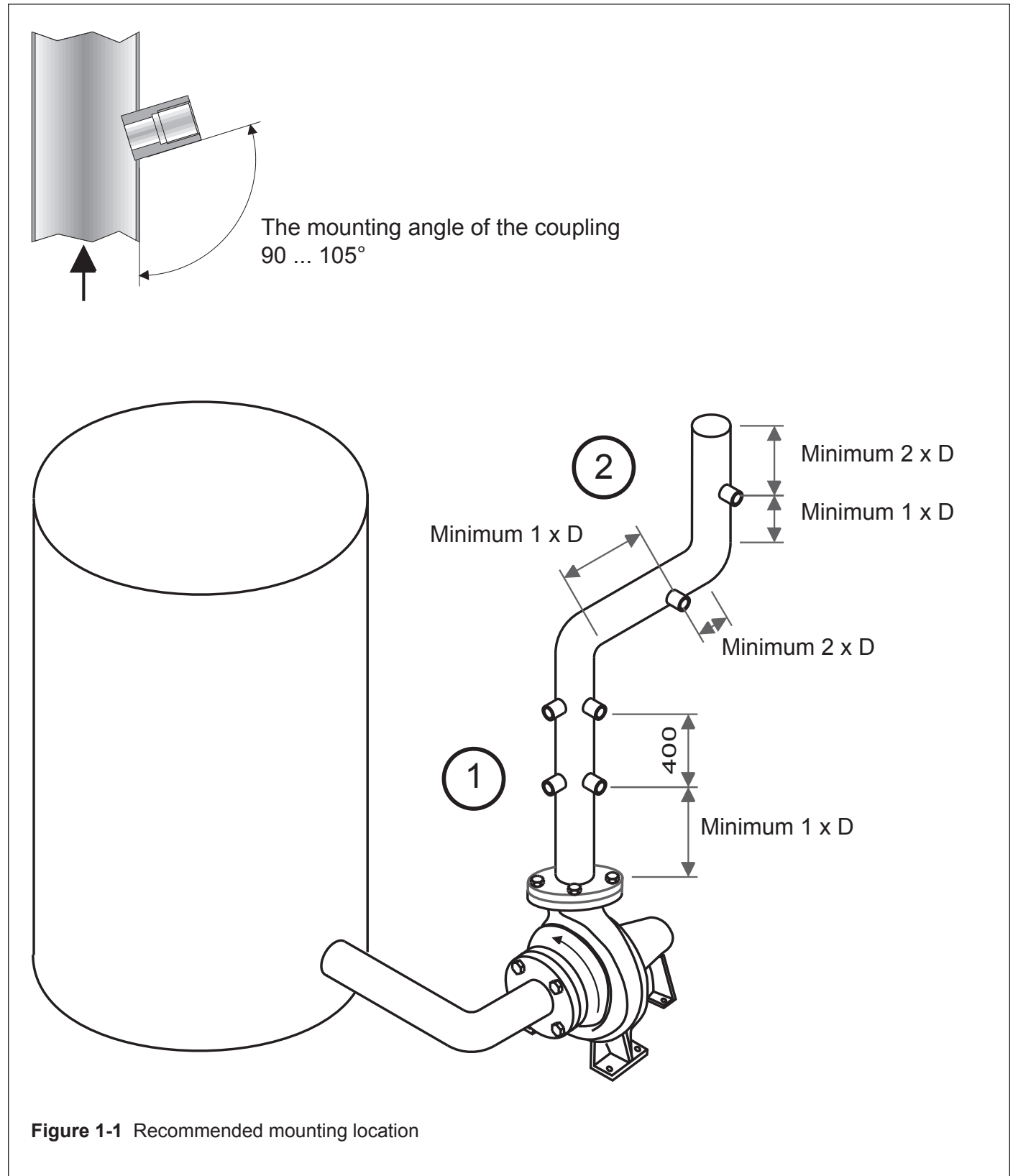

1.2 Installing the transmitter

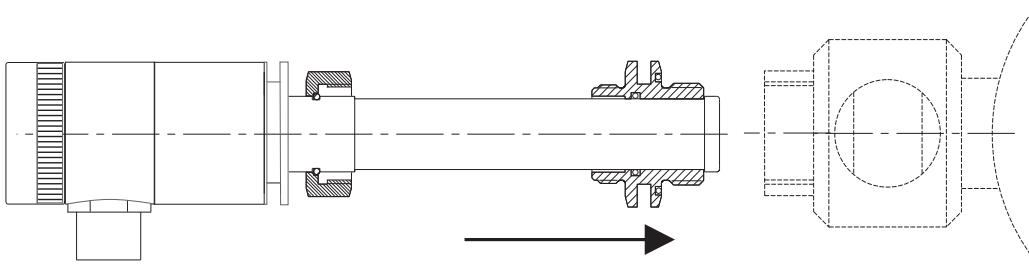

1. Ensure that the installation valve is clean from process media which could damage the transmitter prior to inserting the transmitter into it.

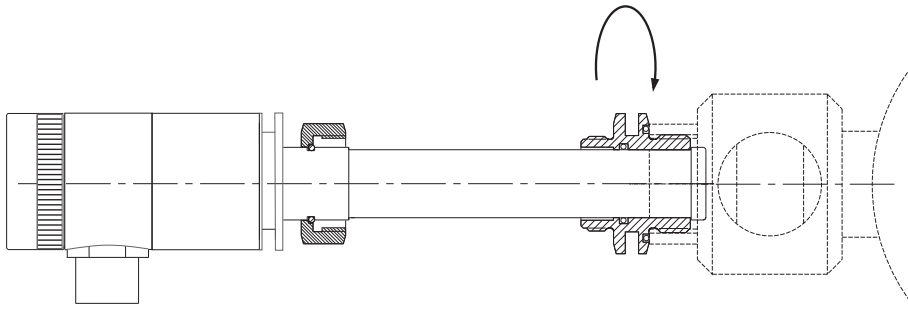

2. Insert the transmitter into the valve and turn to fasten the valve coupler. Tightening torque 40 Nm.

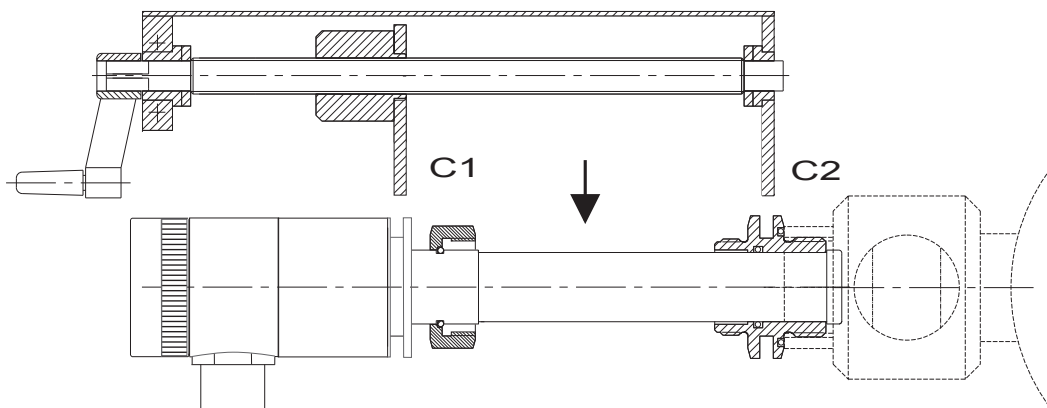

3. Align the installation tool slots (C1 and C2) with the transmitter slots and connect the installation tool.

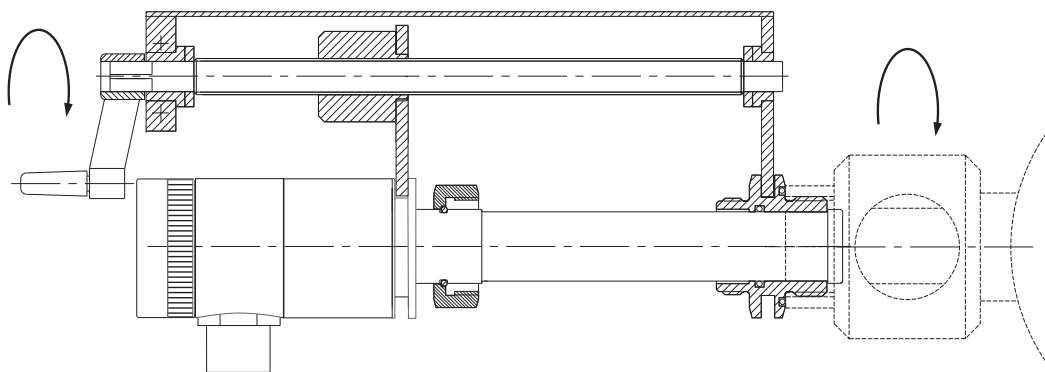

4. Turn the installation ball valve fully open and insert the transmitter into the process, by turning the installation tool lever clockwise.

Figure 1-2a Mounting the transmitter on the coupling

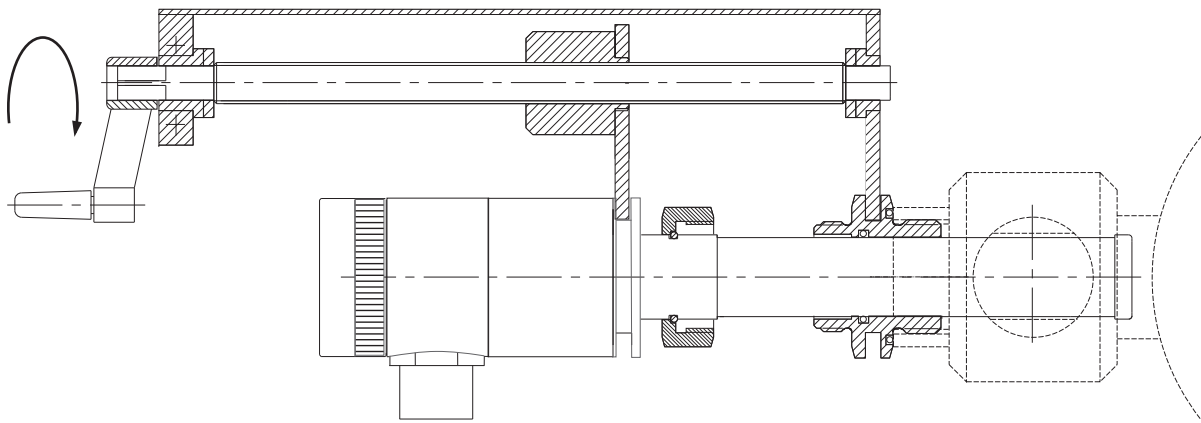

5. Turn the installation tool level until the transmitter is fully inserted into the process.

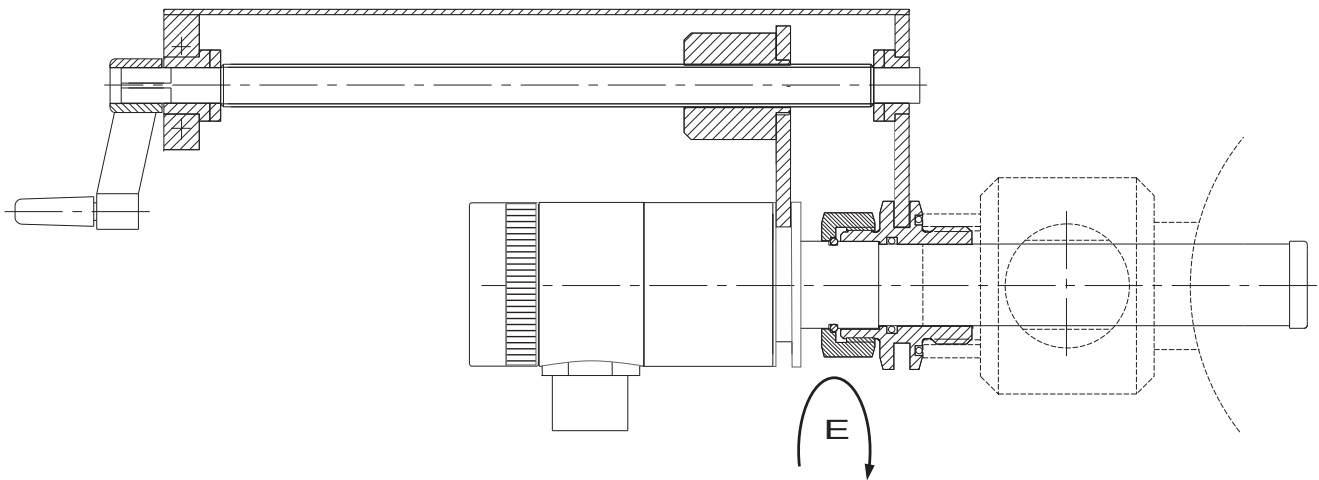

6. Fasten the transmitter in place with the locking nut E, Tightening torque 40Nm.

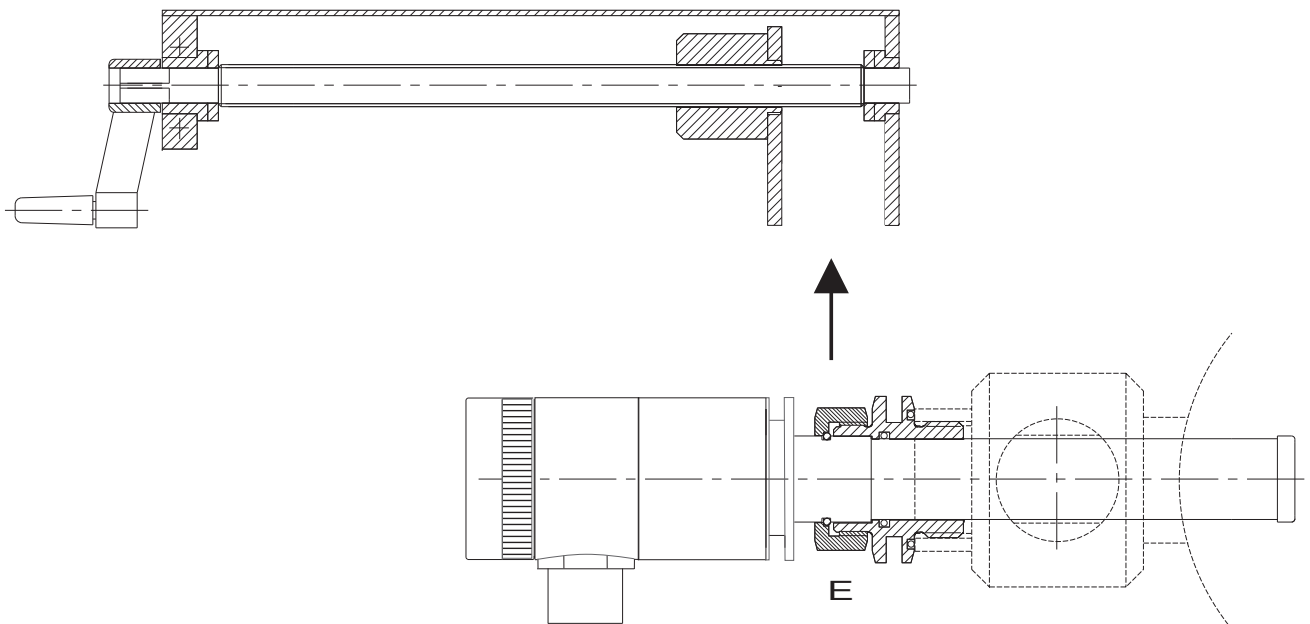

7. Remove the installation tool.
8. To remove the transmitter from the process, reverse the steps shows for inserting the transmitter.

Figure 1-2b Mounting the transmitter on the coupling

SATRON VC Optical Consistency Transmitter

BCs220AV
Revision 1
15.3.2014

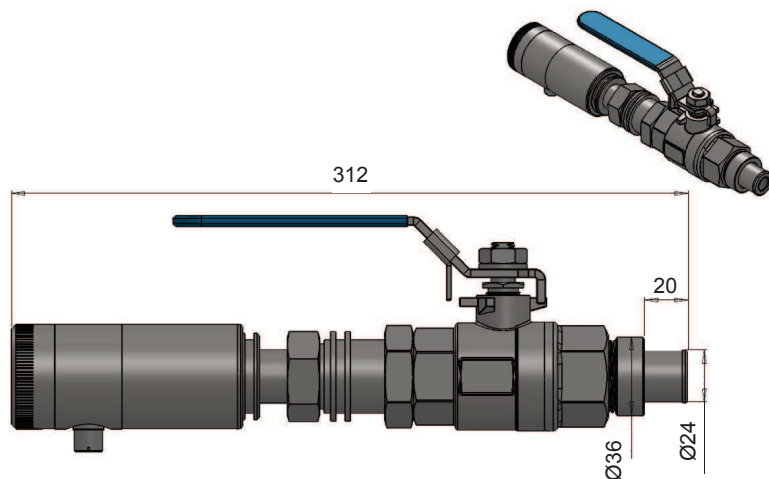

Dimensions Satron VCT

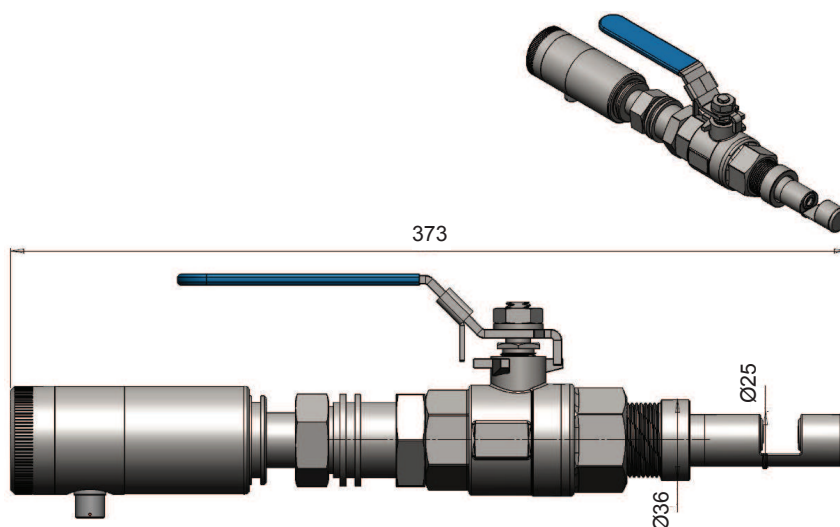

Dimensions Satron VCF

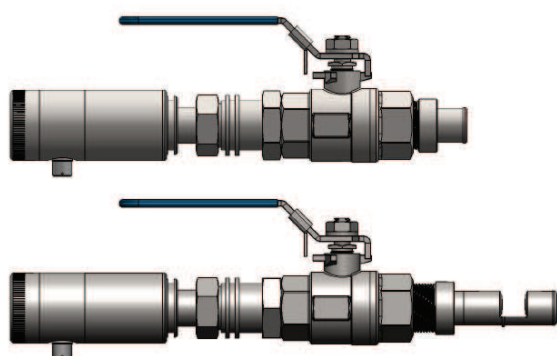

Standard 5 m
Optional 10 m

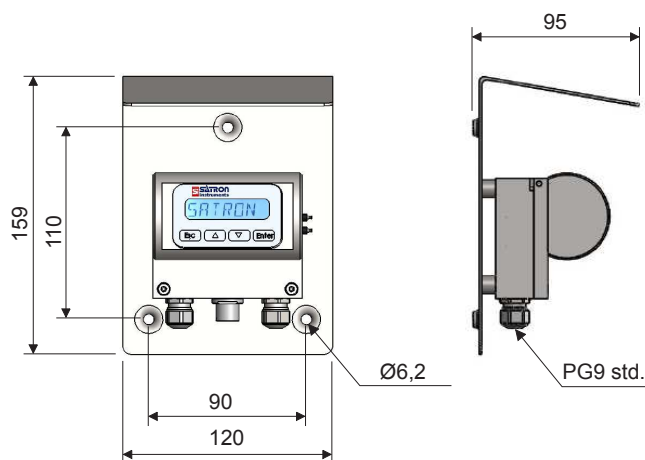
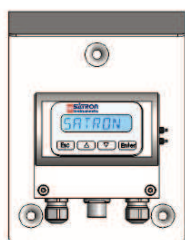

Satron VC with L-housing

1.2 Electrical connections

Supply voltage and load of the transmitter according to the Figure 1-10.

We recommend shielded twisted-pair cable as signal cable.

The signal cable should not be installed near high-voltage cables, large motors or frequency converters.

The shield of the cable is grounded at the power supply end or according to the recommendations of the manufacturer of the used control system.

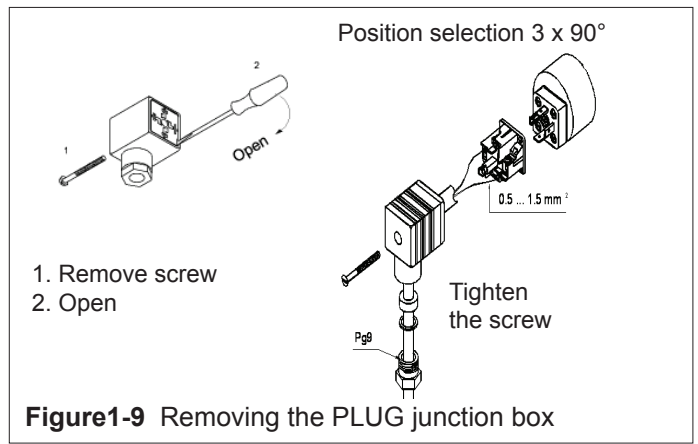

Figure1-9 Removing the PLUG junction box

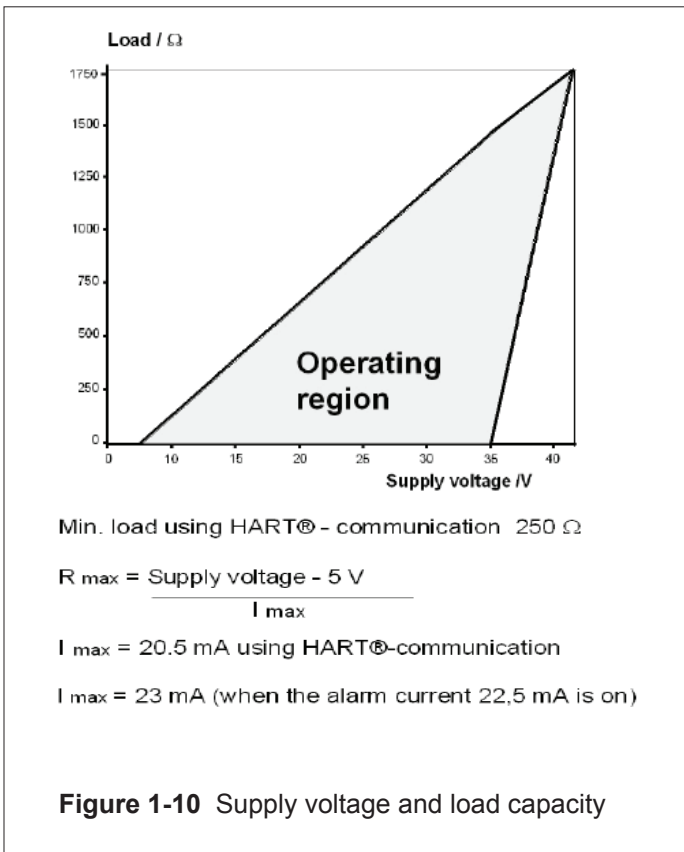

Figure 1-10 Supply voltage and load capacity

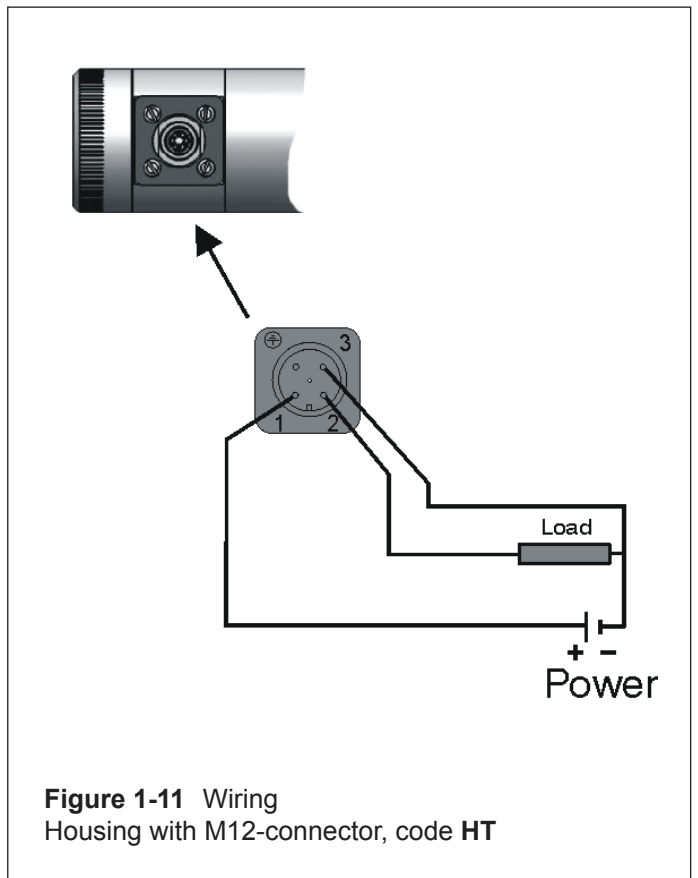

Figure 1-11 Wiring Housing with M12-connector, code HT

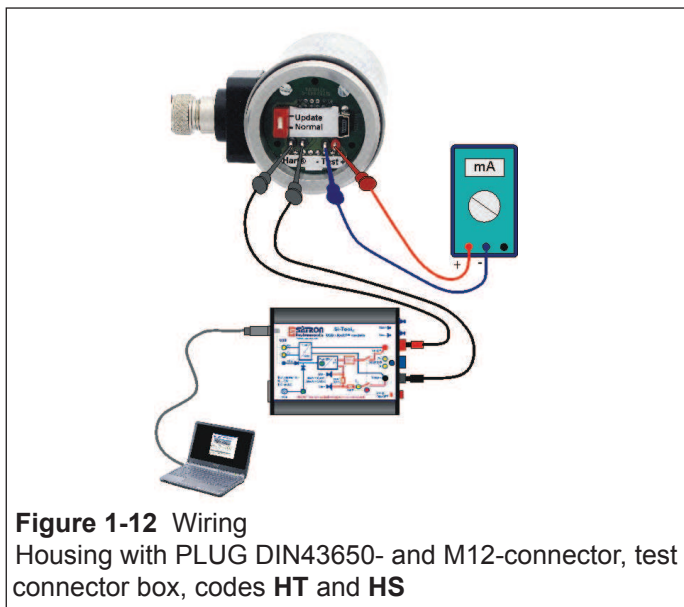

Figure 1-12 Wiring Housing with PLUG DIN43650- and M12-connector, test connector box, codes HT and HS

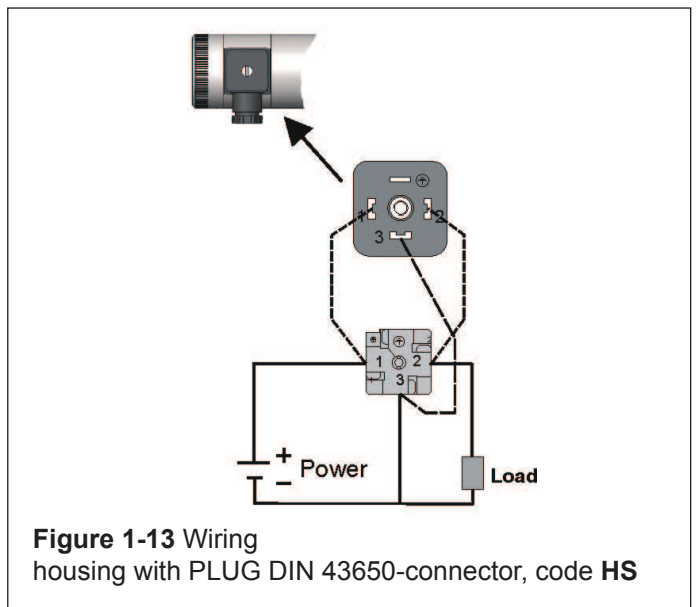
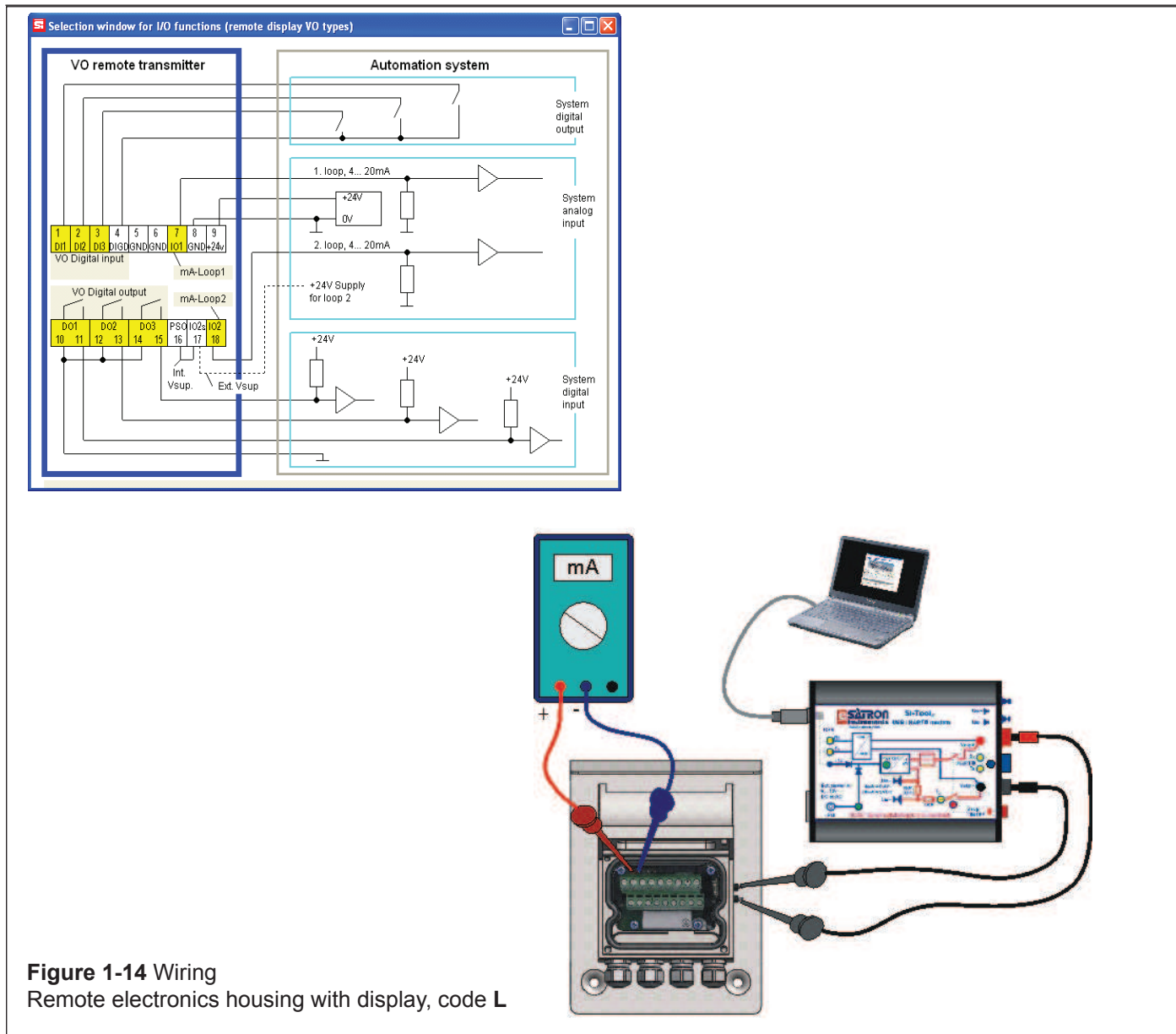

Figure 1-13 Wiring housing with PLUG DIN 43650-connector, code HS

SATRON VC Optical Consistency Transmitter

BCs220AV
Revision 1
15.3.2014



2 SETTING-UP

2.1 Setting-up with Satron-VoAdvisor Service Software

When you want to have all the operations of the Smart transmitter, we recommend the use of Satron-VOadvisor Service Software program. Satron Instruments Inc. will deliver you the program, HART-modem and HP-2133 Mini Note PC according the order.

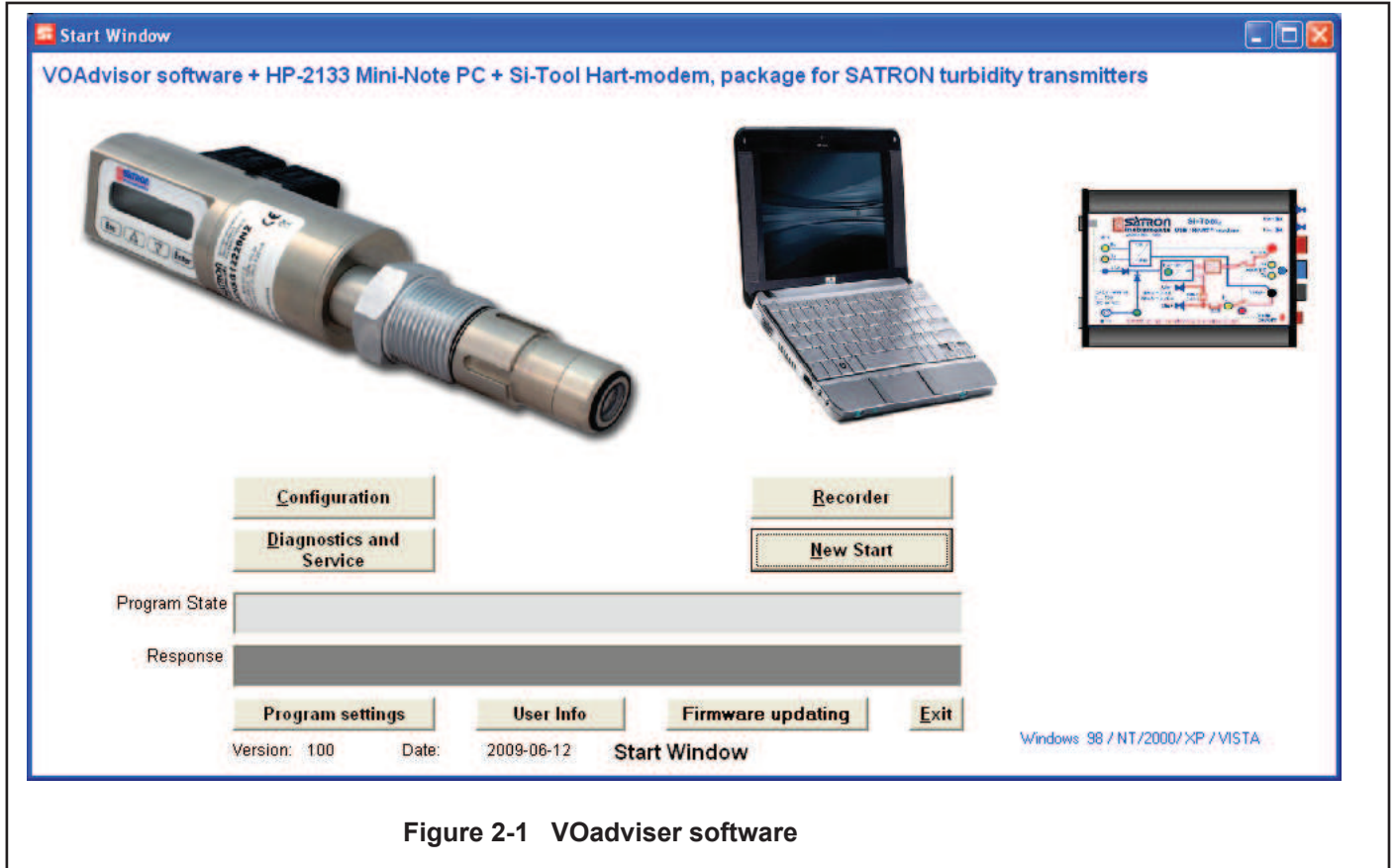

2.2 Setting-up with local switches

The additional instruction of display menus is enclosed to this manual. See chapter 4

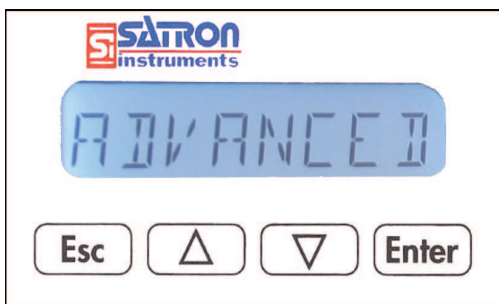

Housing with display, code N

Keyboard :

- Esc = Press **Esc** move back towards the top of the main menu.
- ▲ = Use the **UP** arrow key to move up on the current menu level or to increase the selected parameter value.
- ▼ = Use the **DOWN** arrow key to move down on the current menu level or to decrease the selected parameter value.
- Enter = Press **ENTER** to move to a lower level in a menu or to accept a command or parameter value

Figure 2-2 VC transmitter with display

2.3 Setting-up with remote unit.

The Satron VC transmitter remote unit can be provided with a wall box which is capable of having a 20m cable between the Sensing unit and the Display unit. Inside the Display unit is a terminal where up to 3 binary inputs, 3 relay outputs and 2 analog milliamp loops can be connected. All connections can be used simultaneously. The signal cable between the Display unit and Sensing unit should not be installed near high-voltage cables, large motors or frequency converters.

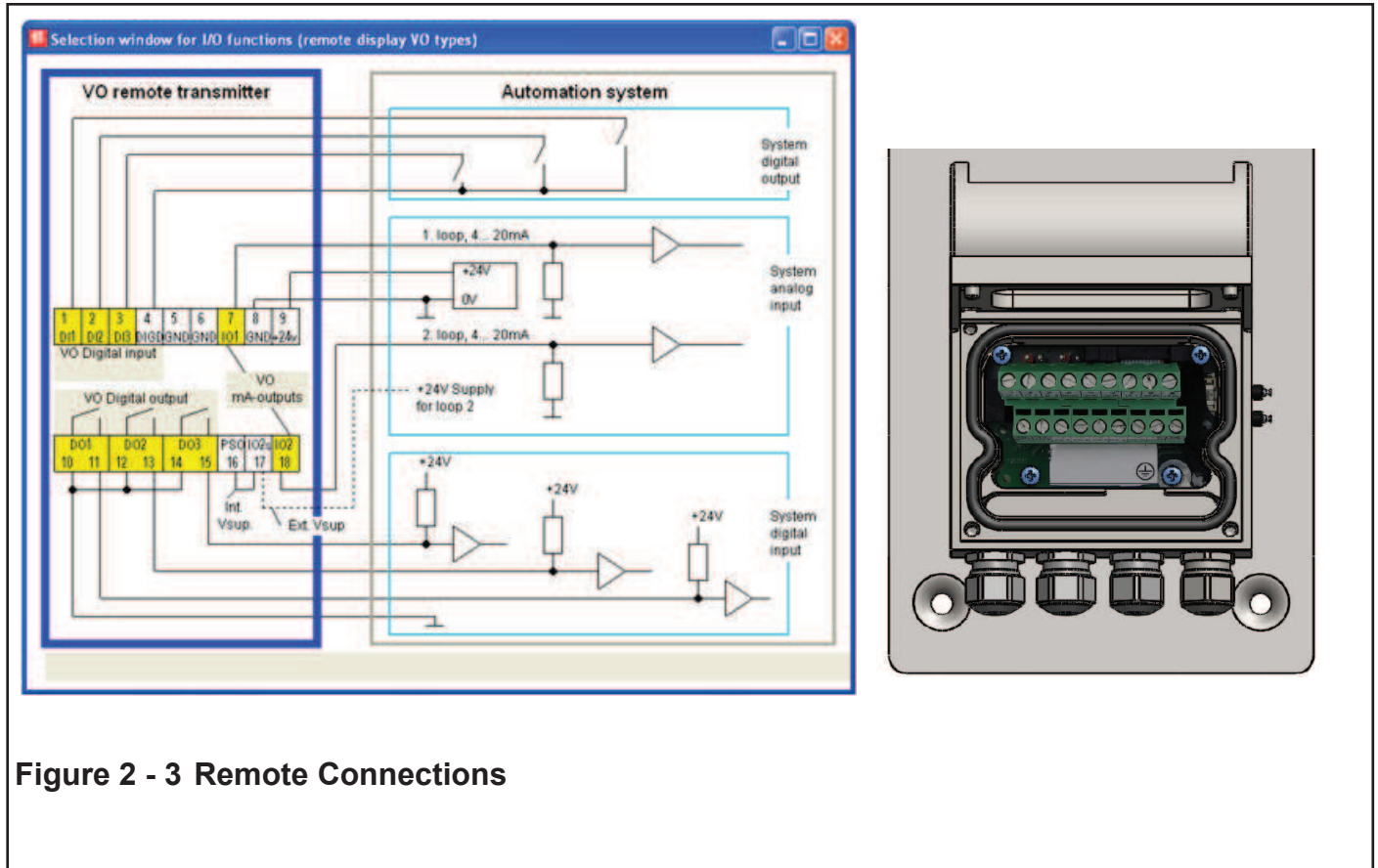

Figure 2 - 3 Remote Connections



Figure 2 - 4 VC Sensing connections.

Inside the Sensing element is a dipswitch and a USB port. This is only used for updating the firmware.

DO NOT USE THE USB PORT UNLESS THERE NEEDS TO BE A NEW FIRMWARE INSTALLED.

3. USER GUIDE FOR MENUS

The user interface for the series VO analyzers, housing option N, consists of display and operating keys. Among other things, the user interface allows you to set process variables in the desired units on the display and to configure the analyzer e.g. by setting the lower and upper range-values. In addition, you can perform diagnostic routines and view device information through the user interface.

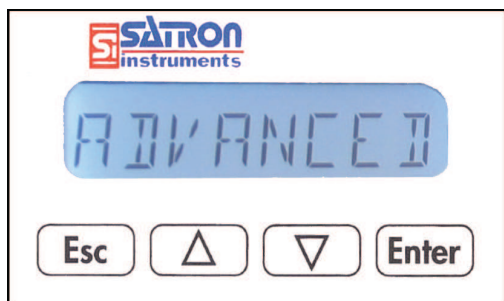

The 8-character liquid crystal display (LCD) with backlight allows you to display information with letters and numbers.

OPERATING KEYS:

With the UP/DOWN arrow keys and the ENTER and ESC you can move in the menus.

ENTER:

Press ENTER to move to a lower level in a menu or to accept a command or parameter value.

UP:

Use the UP arrow key to move up on the current menu level or to increase the selected parameter value.

DOWN:

Use the DOWN arrow key to move down on the current menu level or to decrease the selected parameter value.

ESC:

Press the ESC to move back towards the top of the main menu or cancel the current action.

3.0 MEASUREMENTS VALUES MENU:

When the analyzer is powered up, it immediately shows the MEASUREMENT VALUES.

Use the UP/DOWN keys to move in the menu. The menu does not have any variables adjustable by the user.

Pressing DOWN shows you the following parameters in order.

	the user calibrated information (% Cs)
	the value of the first mA loop
	the temperature of the sensor head
	the temperature of the electronics
	active recipe name

Under the main menu are 6 submenus: Configuration, New Sample, Calibration, Diagnostics and Advanced. To enter these submenu press ESC for 3 seconds.

3.1 Configuration

The transmitter configuration settings

RCP SEL

Active recipe selection menu.

RECIPE 1

Recipe selected options RECIPE (1 ... 4).

The basic factory tuning is stored in the recipe 1.

To perform a new calibration is recommended to use a new recipe.

MAOUTPUT

The current output (mA circuit) settings.

LRV

Lower range value (4 mA)

URV

Upper range value (20 mA)

DAMPING:

Time constant, in seconds for output damping. The range is 0.000s to 60s. Set the value with the UP/DOWN keys and accept it with ENTER or press ESC if you do not want to change the value.

AVERAGE:

Time constant in Hz for averaging the output. The range is 1Hz to 50Hz. Set the value with the UP/DOWN keys and accept it with ENTER or press ESC if you do not want to change the value.

ALARMTYP:

The alarm current (3,7 mA or 22,5 mA).

SYSTEM CONFIGURATION

(configure parameters that have an effect on the system like e.g. language and date.)

TAG:

Tag code. You can enter free-format text one character at a time. When you select this option with ENTER the cursor will be at the left. Select characters with ENTER (to the right) and ESC (to the left). You can view the selectable characters one character at a time with the UP/DOWN keys until the desired character is found. When the cursor is at the right edge you can go back to the SYSTEMCONF menu either by accepting the new tag code with ENTER or by pressing exiting without changing the tag code by pressing the ESC key when asked to accept your entry. Apostrophe indicates the cursor position; at point, however, the cursor will disappear. A great deal of special characters are available besides letters and numbers.

SETCLOCK: **SETCLOCK**

Aika ja pvm(pp.kk.vvvv -hh.mm.ss) asetukset

HART: **HART**

Tässä valikossa tehdään Multidrop-toiminnan asetukset. Multidrop-toiminnassa kaikkien multidrop-väylään asetettujen lähettimien lähtöviesti asettuu 4 mA:iin. Osoitteella 0 on käytössä 4...20 mA:n virtasilmukka, jolloin lähetin toimii normaalisti 4...20 mA signaalilla.

DISPLAY: **DISPLAY**

In this menu you can select the looks in which the display will be read.

BACKLGHT: Select the intensity of the backlighting from **OFF, LOW, MEDIUM** and **HIGH**.

ANGLE: lets you select the angle of the text.

NORMAL: From left to right. Transmitter mounted horizontally with process connection directed to the right.

ROTATED: Rotates the text 180 degrees from **NORMAL**.

PASSWORD: **PASSWORD**

From this menu you can set a password (0...999) for the analyzer. If a password has been specified, you cannot set any parameters or make any other settings on the analyzer unless you enter the correct ID number in this menu. Password is not in use when **PASSWORD** is 000 after reset. You enter the **PASSWORD** in the same way as **TAG**. **PASSWORD** will be on when you define a value between 1 and 999. If you forget password get on to Satron Instruments Inc.

FACTORY

FACTORY:

Restore Factory settings. After entering this menu you will get a warning message that the configurations will be lost after this point. To cancel the procedure press **ESC**.

LANGUAGE: **LANGUAGE**

Select the Display language.
ENGLISH, FRENCH.

T UNIT: **T UNIT**

Selected the temperature unit from this menu. The unit can be Celsius (°C) or Fahrenheit (°F).

PV UNIT: **PV UNIT**

Selected the unit for process value in the display from this menu. (mg/l, % CS ...)

LED CURR: **LED CURR**

(the LED intensity settings)

Select the amount of current, which is used for LED (%)

INFO **INFO**

You can select the device information menu from the Main Menu level with the ENTER key. Use the UP/DOWN keys to view these items. Press ESC key to return to the Main Menu level. You cannot change the data displayed in this menu.

MANUFACTURER: **MANUFACTR**

Manufacturer's name. (SATRON) Cannot be changed.

DEVICE TYPE: **DEV TYPE**

The type code of device. Cannot be changed.

VERSION: **VERSION**

Version numbers of the transmitter's electronics and software. Press ENTER to select this item. Press ESC to exit. With the UP/DOWN keys you can select either CPU HW, CPU SW, ADC HW, ADC SW or MAN REV (manual revision) revision number or CPU ID-number from this submenu.

ASSEMBLY NUMBER: **ASSM NUM**

The analyzers assembly number. Press ENTER to select this item. Press ESC to exit. For instance, assembly number 0901 shows that the transmitter was made in week 01 of the year 2009.

SERIAL NUMBER: **SER NUM**

Serial number. Cannot be changed.

OPERATION TIME: **OP TIME**

The value of the operation time save at 1 hour intervals. When the value of the counter is < 100 hours so value save 1- minute intervals. The value of the operation time counter on the display :

HH :MM :SS when the value of counter is <100 hours

HHHH : MM when the value of counter is <100000 hours

HHHHHHHH when the value of counter is ≥100000

hours

I/O CONFIGURATION **I/O CONF**

Configure parameters that have an effect on the INPUT and OUTPUT relays (VC transmitters with N- and L-housing) Satron highly recommends the use of the software package VOadviser to alter these settings!

I/O 1

Settings menu for input / output, I/O 1...3 (housing type N) or input PIN 1...3, output DOUT 1...3 and IO2 (housing type L)

TYPE: **TYPE**

Select the function (housing type N)

When "NONE" is selected in the I / O is turned off.

To use the digital input to select DIN1. To use the digital outputs, select the DOUT1. To use the second current output configurable external input IO2 select EXT (only I / O 2). To use the second current outputs configurable to select IO2 (only I / O 3)

FUNCTION: **FUNCTION**

The digital input / output function settings

HI LIMIT the digital output will change its state depending on the HI VALUE.

LO LIMIT the digital output will change its state depending on the LO VALUE.

- ERROR AL the digital output will change its state when there is an error.
- WRNG AL the digital output will change its state when there is a warning.
- ERWNG AL the digital output will change its state when there is a error and/or warning.
- HOLD when the digital input is ON the whole unit will be in a hold until the input is OFF.
- NONE no function.
- OFT ACKN the digital input mode [ON] setting off a timer to overfeed.
- RECIPE+1 digital input status [ON]
- RECIPE+2 increase the number of active pre-scription for one (RECIPE 1) or two (RECIPE 2) if the recipe is I / O SEL.
- TRB ZERO the digital input mode [ON] to reset the value of the consistency of the factory.
- DATA LOG the digital input mode is [ON] storing data logging is permitted if the DATA LOG parameter is set to DIGITAL I / O.
- FLSH ON the digital input mode [ON] to set the flush mode to [ON].
- FLSH OFF the digital input mode [ON] to set the flush mode [OFF].
- FLSH OVT digital output is for flushing guidance.

SOURCE: SOURCE

Select the source to which the digital output will change its state.

- PV is the process value selected by the user. (value which is behind "U" on the display).
- MA is the 1st current loop
- ST is the sensor temperature located 5 millimeter behind the optical lens
- RANGE-% this will show a 0 to 100 % value correlating to 4...20mA.

ON DELAY: ON DELAY

On delays can be used to delay digital output state from OFF > ON transitions. The time can be selected in seconds in the range of 0...300s. By default the off delay is not used.

OF DELAY: OF DELAY

Off delays can be used to delay digital output state from ON > OFF transitions. The time can be selected in seconds in the range of 0...300s. By default the off delay is not used.

OF TIMER: OF TIMER

Overfeed timer limits the time that the digital output can be continuously in ON state. The time can be selected in seconds in the range of 1...60000s. By default the overfeed timer is not used. Note: overfeed timer does not function if digital output is overridden by HOLD function, when performing a I/O test in the DIAGNOST menu or with HART CPU Control/ DOOverride.

IO2 SOURCE: IO2 SRC

The source for 2 nd mA out (PV,ST, ET, ...).

IO2 LRV: IO2 LRV

The lower range value for 2 nd mA out (4 mA).

IO2 URV: IO2 URV

The upper range value for 2 nd mA out (20 mA).

IO2 DAMPING: IO2 DAMP

The time constant for 2 nd mA out (0 ... 60 s).

3.2 NEW SAMPLE NEW SAMP

The new sample menu

START: START ?

Store a new sample to memory.

SAMPLE H₂O: SAMPLH2O

Restore the water point to memory.

3.3 CALIBRATION CALIBRAT

The calibration menu.

RECIPE: RECIPE

The settings for active recipe.

OFFSET: OFFSET

The offset correction for calibration (default 0.0)

GAIN: GAIN

The gain correction for calibration (default 1.0)

USER.PNTS: USERPNTS

The number of points for multipoint calibration. POINT.CNT calibrated count the number of points 1 ... 16.

Their point of entry is given a number in either the keyboard (EDIT) or by saving the real-time measurement (SAMPLE).

Point out the value of the pair (user selectable unit) is given a number in the keypad.

See the section of this manual for an example of tuning to get more information on the complete re-calibration.

USER MODE: USERMODE

Select the method of interpolation between the points.

INTERPL Select a linear interpolation.

SPLINE Select the spline curve with interpolation.

TEXT: TEXT

Select the user name for the recipe.

SAMPLES: SAMPLES

The history of the sample (10). Laboratory values input.

SAMPLE 01: **SAMPL 01**
Upload a sample 1.

SAMPLE 09: **SAMPL 09**
Upload a sample 9.

SAMPLE H₂O: **SAMPLH2O**
The water value

CALIBRATE: CALIBRAT

Calibration with sample (1/2-point).

SAMPLE 01: **SAMPL 01**

SAMPLE 09: **SAMPL 09**

SAMPLE H₂O: **SAMPLH2O**
The calibration list of suitable samples (samples recorded fed laboratory value).

CALIBRATION HISTORY: CALIBRAT

Transmitter calibration history.

01 2013--

The date / time stamped list of calibrations.

3.4 DIAGNOSTICS **DIAGNOST**

(This submenu allows you to examine the transmitter's internal errors and faults, to set the transmitter to give out a fixed current, and to calibrate the transmitter.)

STATUS: STATUS

Here you can display and reset accumulated errors one at a time. The text OK will be displayed if there are no errors. Possible error messages (alarm means a serious fault/error that also puts the current signal in fault status and makes the display blink).

Table 1, the content of error word 1, page 18.

LOOPTEST: LOOPTEST

The transmitter can be set to give out a fixed current signal for testing the mA output. The first ENTER will switch the transmitter off from normal mode (AUTO OFF), the second ENTER will set it for 4 mA output, and the third ENTER for 20 mA output. The next ENTER after that will give default value 12 mA, which can be changed as desired with the UP/DOWN keys. The last ENTER will switch the transmitter back to normal mode (AUTO ON). The purpose of this test is to test the accuracy of the transmitter's current output with a reference meter.

TRB TRIM: TRB TRIM

The transmitter calibration factory units (FU).

- TRB ZERO measurement of zero
- Calibration of measurement by two points
- LRW.TRIM calibration of the lower point
- UPR.TRIM calibration of the upper point
- REMOVE delete of calibration

SENSOR TEMPERATURE TRIM: ST TRIM

Sensor Temperature Trim. Here you are able to calibrate the temperature probe which is placed in the head of the analyzer. (Maximum by 10 degrees.)

LOOP CALIBRATION: LOOPCAL

Here you can calibrate the current signal given by the transmitter. The first ENTER will switch the transmitter off from normal mode (AUTO OFF). The next ENTER will make the transmitter give out a signal which it assumes to be 4 mA. Use the UP/DOWN keys to change this value in accordance with the reading on the reference meter. Then press ENTER for 20 mA output, which you must also set in accordance with the reference meter. Press ENTER to accept the new reading.

Note: Use a sufficiently accurate reference meter.

I/O TEST: I/O TEST

The digital inputs and outputs, as well as the power output of the second test. Income status is displayed on the screen and change the status of the outputs

HARDWARE: HARDWARE

- VOLTAGES the voltage diagnostics
- I/O COMM device I / O communication diagnostic diagnostics (only housing type L)

LOG: LOG

- ADD TXT text (8 characters) increase in the event log
- DATA LOG data log mode:
- CYCLIC continuous (default)
- DIC I/O selected with digital inputs
- OFF off

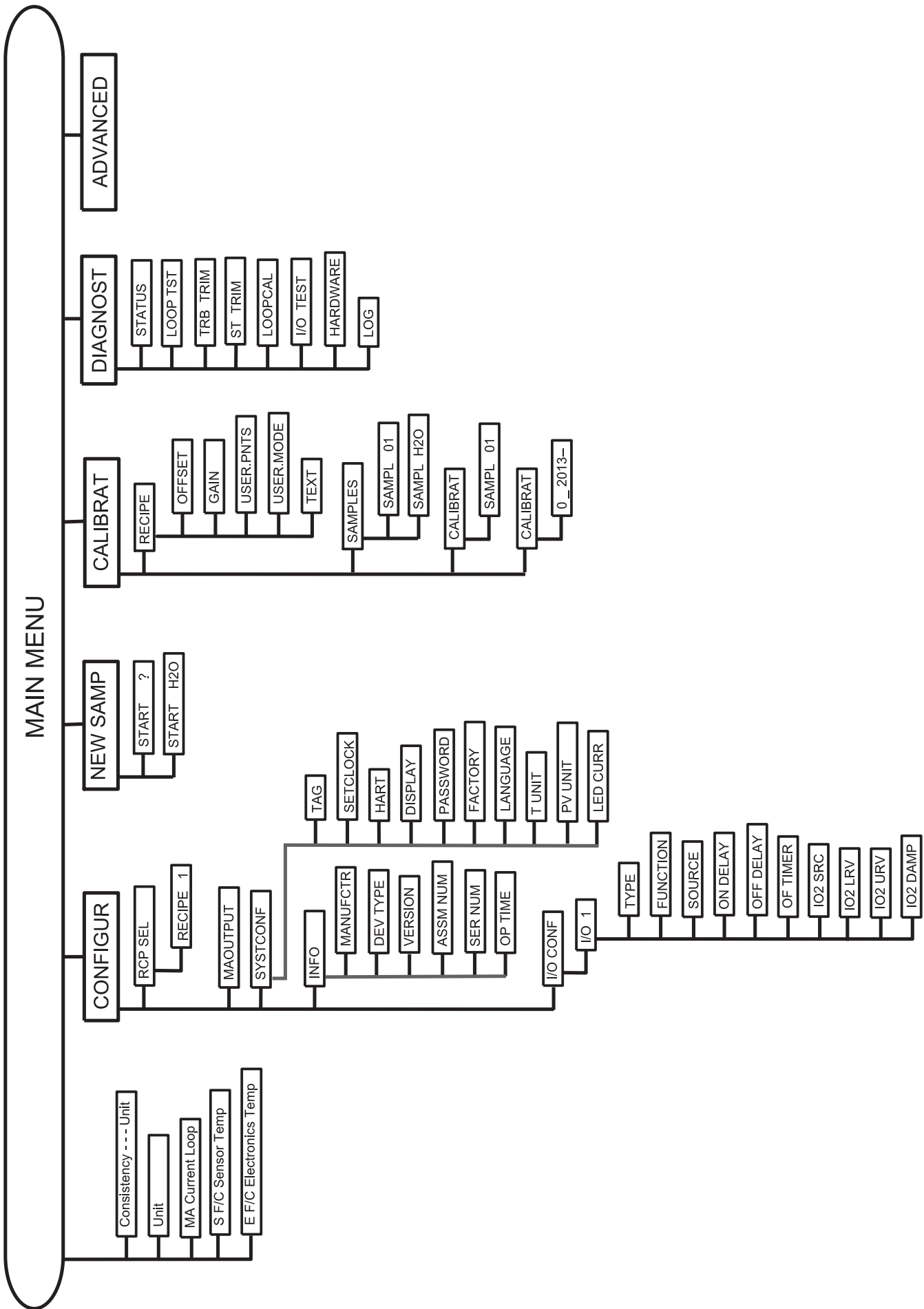

MAIN MENU

4. SETTINGS

4.1 Basic settings

100 %CS Press the ESC-button to enter the menu.

Esc

CONFIGUR Select CONFIGURATION and press the ENTER-button.

Enter

RCP SEL Press [▼]-button and select MAOUTPUT and press the ENTER-button.

▼

MAOUTPUT

Enter

LRV Select LRV (mA-output lower range value 4mA) and press the ENTER-button.

Enter

00000000 Place the decimal separator with the [▼][▲] and press the ENTER-button.

Enter

20000000 Insert lower range value (4 mA) with the [▼][▲] and press ENTER-button, until upper separator reaches the right end of display.

▼ ▲ Enter

Enter

SAVE ? Press ENTER-button to store the lower range value for mA-output.

Enter

LRV Press the [▼]-button and select URV (mA-output upper range value 20mA) and press ENTER-button.

▼

URV

Enter

Place the decimal separator with [▼][▲]-buttons and press ENTER-button.

70000000

Enter

40000000 Insert upper range value (20 mA) with the [▼][▲] and ENTER-buttons, until upper separator reaches the right end of display.

▼ ▲ Enter

Enter

SAVE ? Press ENTER-button to store the upper range value for mA-output.

Enter

URV

▼

DAMPING Press the [▼]-button and select DAMPING (time constant for mA-output damping) and press the ENTER-button.

Enter

05 5 Set the time constant with the [▼][▲]-button and press the ENTER-button.

▲ ▼ Enter

SAVE ? Press the ENTER-button to store the time constant for mA-output damping.

Enter

DAMPING

▼ ▼

ALARMTYP Press [▼]-button and select ALARMTYP and press the ENTER-button.

Enter

3.7 MA Set alarm current with the [▼][▲]-buttons (3.7 or 22.5mA) and press the ENTER-button

▲ ▼ Enter

SAVE ?

Enter

ALARMTYP Press the ENTER-button to store the alarm current value.

Esc

Press the ESC-button to return to the main measuring screen.

Esc

100 %CS

4.2 Collect sample

100 %CS Press the ESC-button to enter the menu.

Esc

CONFIGUR

▼

NEW SAMP Press the [▼]-button and select NEW SAMPLE and press the ENTER-button.

Enter

START ? Press the ENTER-button and activate sampling.

Enter

SAMPLING The screen will blink SAMPLING text during sampling process. Press the ENTER-button when sample has been taken to end sampling.

Enter

SAVE ? The sampling time stamp, average and min and max cs-values during the sampling process are shown on display. Press the ENTER-button to store the sample or press ESC to cancel.

Enter

SAMPL 01

4.3 Laboratory values

100 %CS Press the ESC-button to enter the menu.

Esc

CONFIGUR

▼

NEW SAMP Press the [▼]-button and select CALIBRATION and press the ENTER-button.

▼

CALIBRAT Press the [▼]-button and select SAMPLES and press the ENTER-button.

Enter

RECIPE

▼

SAMPLES Select with the [▼][▲]-buttons the desired sample point to which laboratory value will be inserted and press the ENTER-button.

Enter

SAMPL 01 Place the decimal separator with [▼][▲]-buttons and press the ENTER-button.

▼ Enter

00000000

▲ Enter

1.2200000 Insert the laboratory value with the [▼][▲] and the ENTER-buttons and press the ENTER-button until upper separator reaches the right end of display.

▲ Enter

0 k

Esc Esc

100 %CS Press the ESC-button to return to the main measuring screen.

4.4 Start-up calibration

2-point calibration with water and one sample point

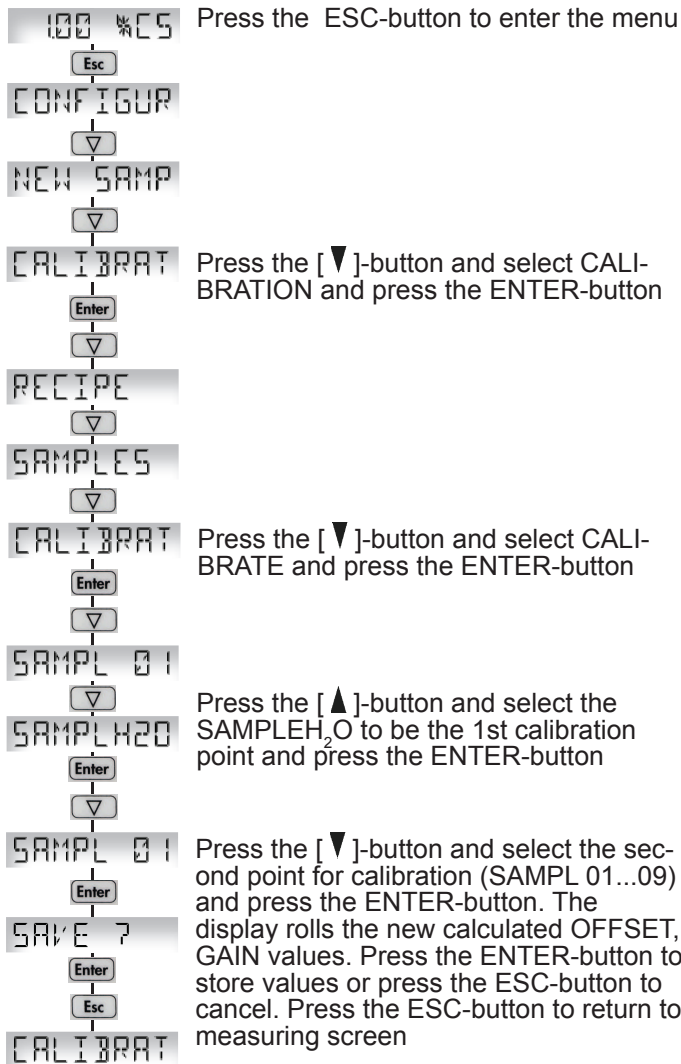

4.5 1-Point calibration

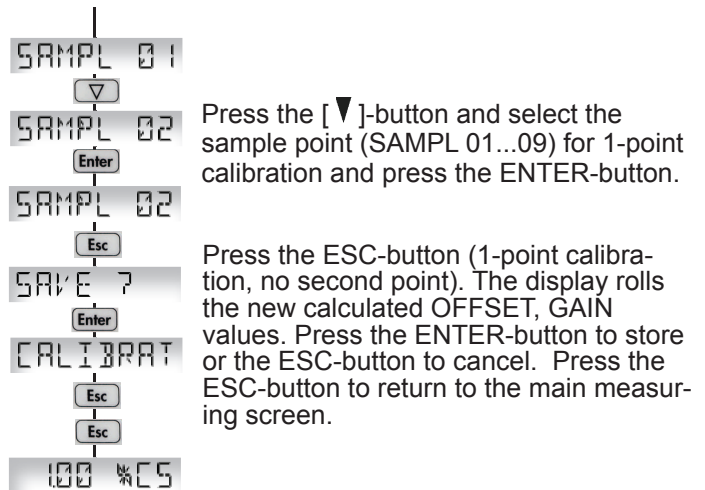
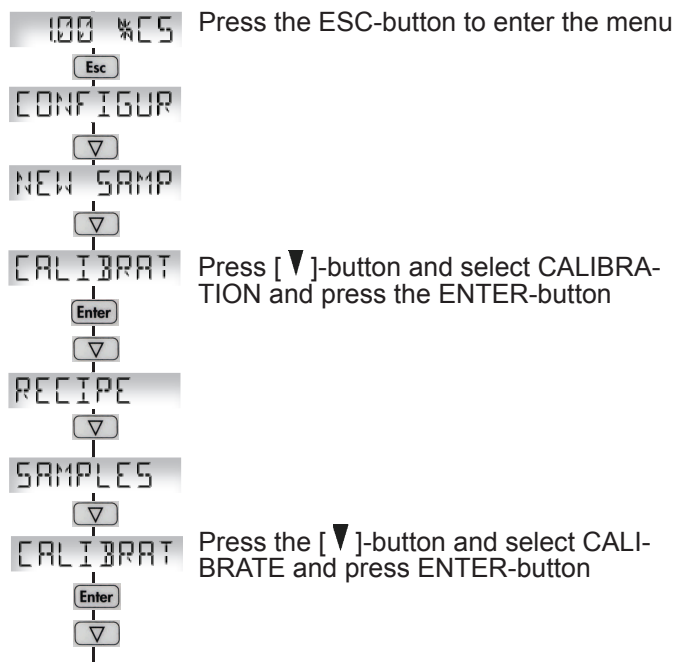

4.6 2-Point calibration

2-point calibration with two sample points

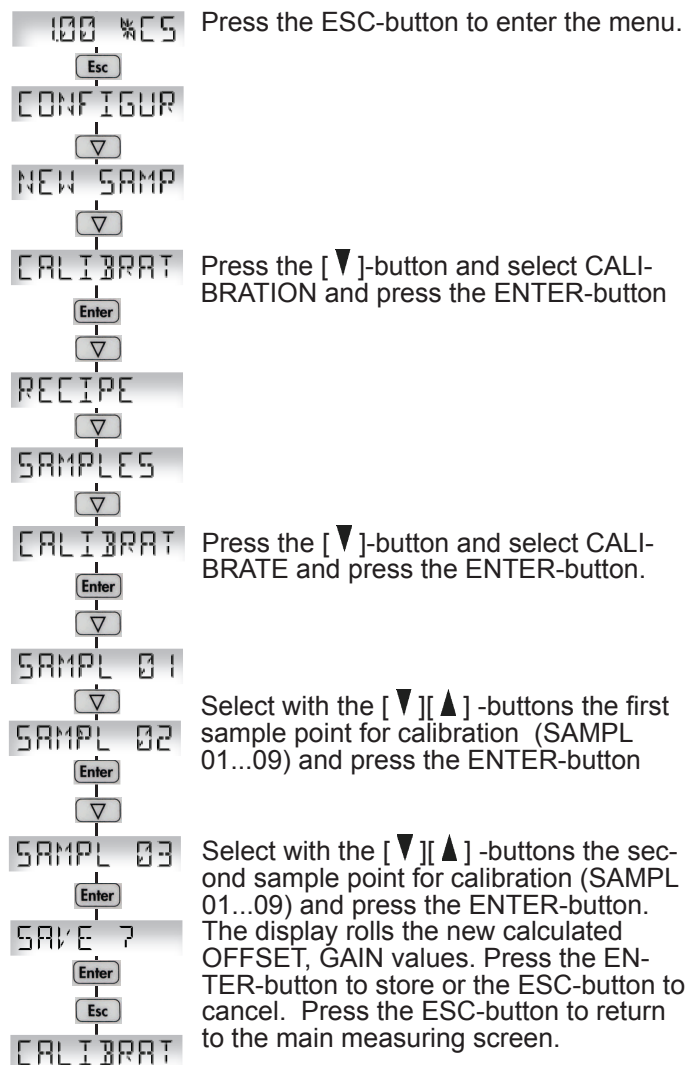

4.7 OFFSET adjustment

100 %CS Press the ESC-button to enter the menu.

Esc

CONFIGUR

NEW SAMP

CALIBRAT Press the [▼]-button and select CALIBRATION and press the ENTER-button.

Enter

RECIPE Select RECIPE and press the ENTER-button.

Enter

OFFSET Select OFFSET and press the ENTER-button.

Enter

0.00000000 Place the decimal separator with [▼][▲]-buttons and press ENTER-button.

0.00000000

1.22000000 Insert the OFFSET value with the [▼][▲] and ENTER-buttons, until upper separator reaches the right end of display.

Enter

SAVE ? Press the ENTER-button to store the OFFSET value.

Enter

OFFSET

Esc

Esc

Esc

100 %CS Press the ESC-button to return to main measuring screen.

4.8 GAIN adjustment

100 %CS Press the ESC-button to enter the menu.

Esc

CONFIGUR

NEW SAMP

CALIBRAT Press the [▼]-button and select CALIBRATION and press the ENTER-button.

Enter

RECIPE Select RECIPE and press the ENTER-button.

Enter

OFFSET

GAIN Press the [▼]-button and select GAIN and press the ENTER-button.

Enter

0.00000000 Place the decimal separator with [▼][▲]-buttons and press ENTER-button.

▼ ▲ Enter

0.00000000

▼ ▲

1.22000000 Insert the GAIN value with the [▼][▲] and ENTER-buttons, until upper separator reaches the right end of display.

Enter

SAVE ? Press the ENTER-button to store the GAIN value.

Enter

OFFSET

Esc

Esc

Esc

100 %CS

4.9 TIME and DATE settings

100 %CS Press the ESC-button to enter the menu.

Esc

CONFIGUR Press the [▼]-button and select CONFIGURATION and press the ENTER-button.

Enter

REP SEL

MAOUTPUT

SYSTCONF Press the [▼]-button and select SYSTCONF and press the ENTER-button.

Enter

TAG

SETCLOCK Press the [▼]-button and select SETCLOCK and press the ENTER-button.

Enter

0 10 12008 Insert date with the [▼][▲]-buttons (dd.mm.yyyy), press the ENTER-button to move dd->mm->yyyy and press the ENTER-button.

▼ ▲ Enter

17052013

Enter

00:00:00 Insert time with the [▼][▲]-buttons (hh.mm.ss), press the ENTER-button to move hh->mm->ss and press the ENTER-button.

▼ ▲ Enter

10:10:10

Enter

SETCLOCK

Esc

Esc

Esc

100 %CS Press the ESC-button to return to main measuring screen.

Table 1.
The content of error word 1
(EW1=0...15)

Bit	Error message	Description
0	TU ER	Process value error
1	ST ER	Sensor temperature (ST) error
2	ET ER	Electronics temperature (ET) error
3	RANGE ER	Percentage of output under -10% or over 110% error
4	OUTSA WA	Output current saturated
5	ADCR ER	ADC converter runtime error
6		
7		
8	ADCS ER	ADC converter startup error
9	EEPRR ER	EEPROM checksum error
10	EEPRW ER	EEPROM write error
11	EECAL ER	EEPROM calibration error
12	HART ER	HART communication error
13	INTRN ER	Internal system error
14	OFTMR WA	Overfeed timer warning
15		



Satron Instruments Inc.
www.satron.com
P.O.Box 22, FI-33901 Tampere, Finland
Tel. +358 207 464 800, Telefax +358 207 464 801