

ultimateSteam

short absorption
steam manifolds

CAREL

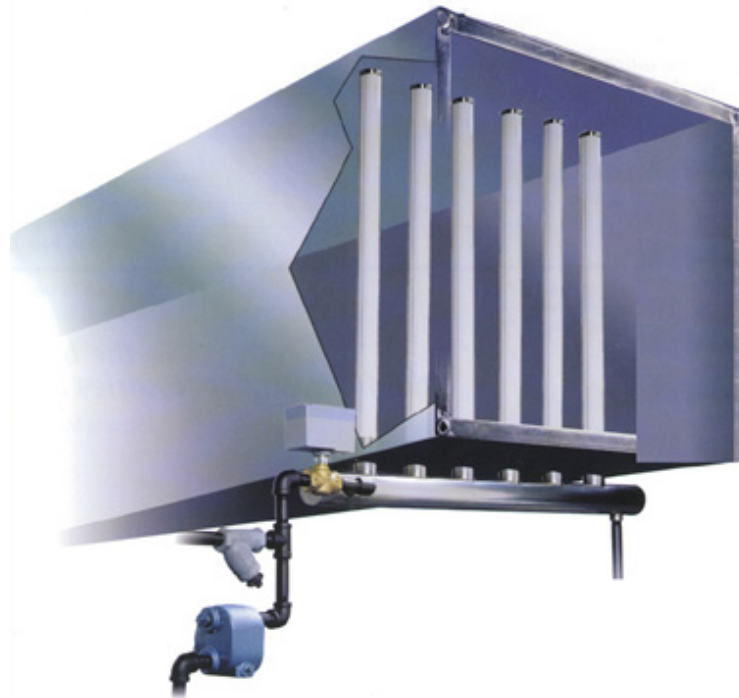

ENG User manual

➔ READ AND SAVE
THESE INSTRUCTIONS ➔

TABLE OF CONTENTS

1. MODEL SELECTIONS	5
2. INSTALLATION	6
LOCATE THE ULTIMATESTEAM MANIFOLD	7
TO DETERMINE THE ULTIMATESTEAM EVAPORATION DISTANCE (ENGLISH):	8
NOMOGRAPH FOR DETERMINING ULTIMATESTEAM EVAPORATION DISTANCE:	8
TO DETERMINE THE ULTIMATESTEAM EVAPORATION DISTANCE (METRIC):	9
NOMOGRAPH FOR DETERMINING ULTIMATESTEAM EVAPORATION DISTANCE:	9
ASSEMBLE AND MOUNT THE ULTIMATESTEAM MANIFOLDS	10
DSO SINGLE MANIFOLD MODELS	10
DSB BOTTOM FED MANIFOLD MODELS	11
ASSEMBLE VERTICAL MANIFOLDS	11
VERTICAL UPRIGHT INSERTION	12
MOUNTING THE MANIFOLDS	13
INSTALLATION CLAMPS FOR DST & DSB	14
AIR HANDLER MOUNTING	15
DST TOP-FED MODELS	15
AIR HANDLER INSTALLATION	16
ASSEMBLE CONTROL VALVE ASSEMBLY	17
ASSEMBLE STRAINER & TRAP ASSEMBLY AND VALVE ASSEMBLY	19
1" STRAINER & TRAP ASSEMBLY	19
2" STRAINER & TRAP ASSEMBLY	20
CONNECT CONTROL VALVE & TRAP TO STEAM SUPPLY AND MANIFOLD	21
DSO SINGLE MANIFOLD MODELS	21
DSB/DST MULTIPLE MANIFOLD MODELS	21
FINAL PLUMBING OF STEAM	22
SUPPLY AND CONDENSATE DRAINS	22
MOUNT VALVE ACTUATOR	22
THE DSA004E001 ELECTRONIC VALVE ACTUATOR	22
THE DSA004E002 ELECTRONIC VALVE ACTUATOR:	23
THE DSA004P001 PNEUMATIC VALVE ACTUATOR	23
THE DSA004P002 PNEUMATIC VALVE ACTUATOR	24
THE DSA004P003 PNEUMATIC VALVE ACTUATOR	24
CONTROLS INSTALLATION	25
CONTROLS WIRING	26
INSTALLATION CHECKLIST	30
3. STARTUP	30
4. OPERATION	31
5. MAINTENANCE	31
6. TROUBLE-SHOOTING	31
7. TECHNICAL SPECIFICATIONS	33
8. LIMITED WARRANTY	33

IMPORTANT: BEFORE beginning installation:

- Check for shipping damage to cartons. Mark the shipping waybill accordingly
- Open cartons and check for any hidden damage. Mark the shipping waybill accordingly.
- Check packing slip to ensure all items have been received. Notify Carel LLC of any shortages or damaged parts. **You must notify Carel LLC within 5 working days of any shortages.**

IMPORTANT: The black coating on the *ultimateSteam* manifolds is insulation, NOT packing material. DO NOT SCRAPE IT OFF.

1. MODEL SELECTIONS

DS								00000
DS = ultimateSteam	Type	Width = In. (mm) <i>Actual dimensions listed</i>			Height = In. (mm) <i>Actual dimensions listed</i>			Version
		DSO**	DSB**	DST**	DSO**	DSB**	DST**	
	0=single pipe	A=11 (280)				A=12 (305)		Internal Use Only
	B=bottom fed	B=17 (432)	B=24(610)			B=18 (450)		
	T=top fed	C=23 (585)	C=30(762)			C=24 (610)	C=20(508)	
		D=35(889)	D=42(1067)	D=42(1067)		D=28 (711)	D=32(813)	
		E=47 (1194)	E=54(1372)	E=54(1372)		E=40(1016)	E=44(1118)	
		F=59 (1499)	F=66(1676)	F=66(1676)		F=52(1320)	F=56(1422)	
		G=71 (1803)	G=78(1981)	G=78(1981)		G=64(1626)	G=68(1727)	
			H=90(2286)	H=90(2286)		H=84 (2100)	H=80(2032)	
			I=102(2591)	I=102(2591)		I=88(2235)	I=92(2337)	
			L=114(2896)	L=114(2896)		L=100(2540)	L=104(2642)	
			M=126 (3200)	M=126 (3200)		M=112(2845)	M=116(2946)	

NOTE: DSB width starts at "B" length and DST width starts at "D" length.
Each UltimateSteam unit is provided with a data label:

****NOTE: ACTUAL DIMENSIONS SHOWN.**

CAREL	
ultimateSteam	
ORDER CODE	DSTGH00000
MAX. CAPACITY	2200 LBS/HR (1000 KG/HR)
SERIAL NUMBER	U000036
MFG DATE	04/18/2006

NOTE: MAX CAPACITY is the maximum capacity of the ultimateSteam manifold assembly. The actual capacity for any project is controlled by the valve orifice Cv.

2. INSTALLATION

To install an UltimateSteam humidifier, you should have:

- The UltimateSteam humidifier manifolds, distribution pipes and escutcheon plates
- Steam valve body and plumbing kit
- Steam valve actuator (pneumatic or electronic)
- Steam trap, strainer and plumbing kit
- Humidistats and controls

Tools needed:

- Sheet metal shears
- Self-tapping sheet metal screws
- Phillips screwdriver and flat blade screwdriver for self-tapping sheet metal screws
- 2 - monkey or pipe wrenches
- Iron pipe thread sealant

Three Systems For Flexibility

DS0* - Single pipe - up to 100 lbs/hr (45 kg/h) per pipe

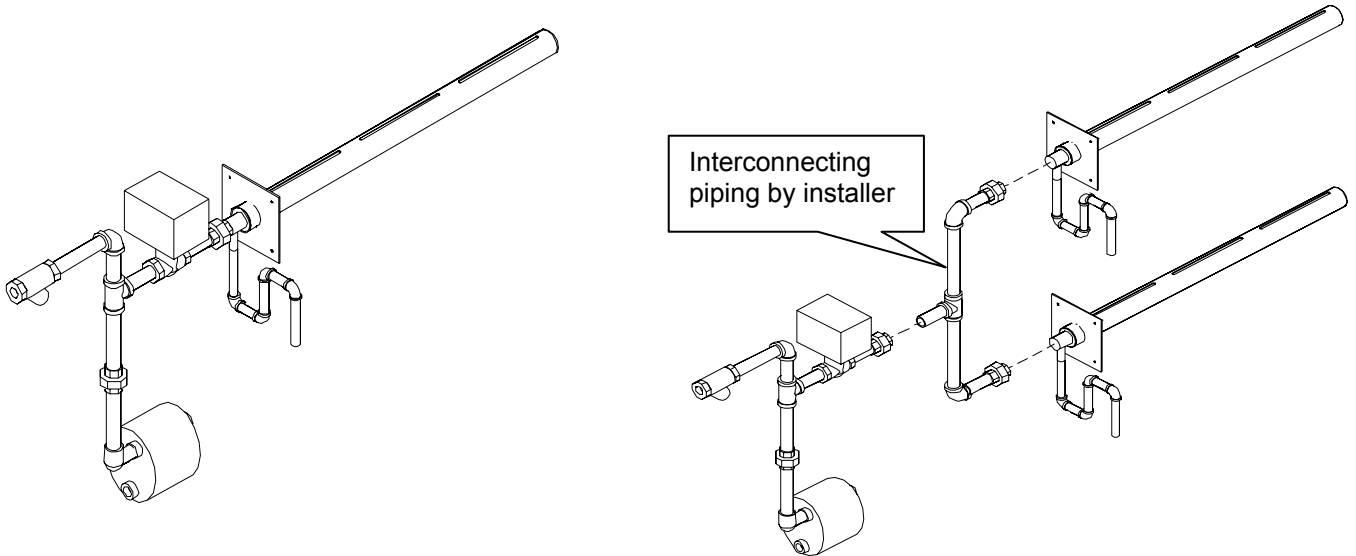

DSB* - Multi-pipe/bottom feed - up to 541 lbs/hr (246 kg/h)

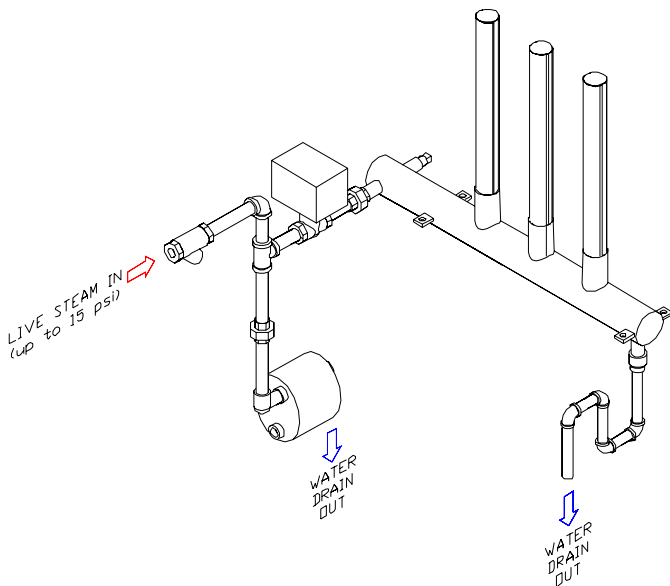

DST* - Multi-pipe/top feed - up to 2,200 lbs/hr (1000 kg/h)

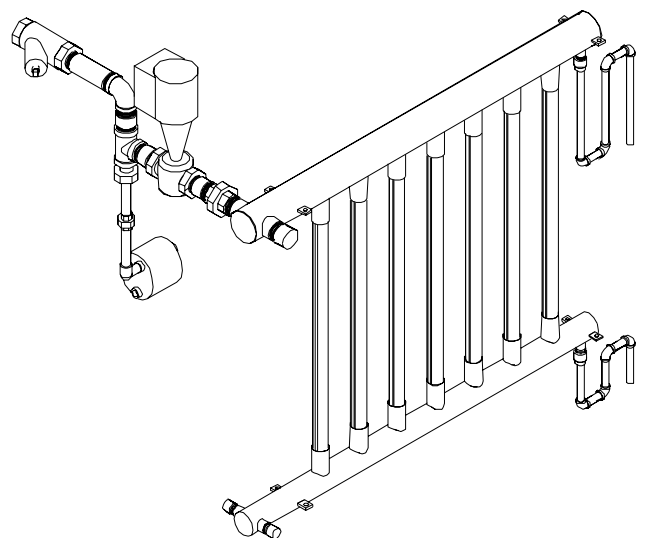

2.1 LOCATE THE ULTIMATESTEAM MANIFOLD

Properly locating the UltimateSteam humidifier and its controls in your air handler or duct is very important - most steam absorption problems are the result of improper installation.

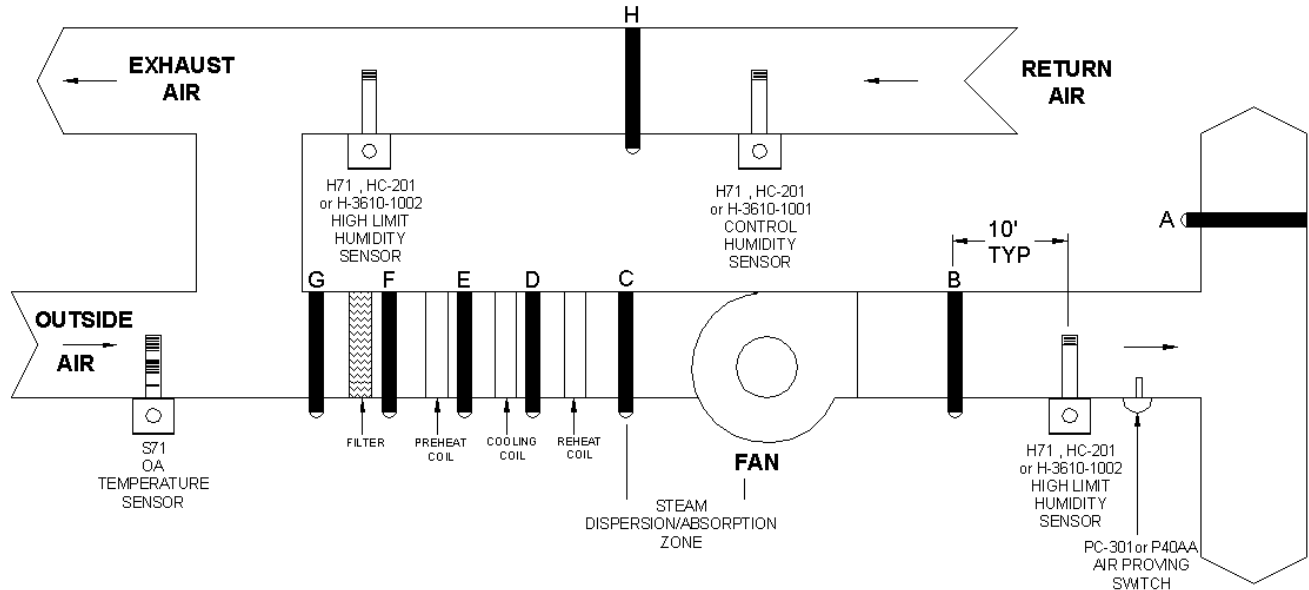

Locations:

- A. BEST: locate far enough from elbow to be in laminar air flow. Maintain evaporation distance.
- B. BEST: locate with enough distance for proper evaporation and to avoid turbulence from the fan.
- C. GOOD: providing there is enough distance for proper evaporation from the humidifier manifold to the fan inlet (back of fan doesn't really matter).
- D. OK: providing there is enough distance for proper evaporation from the humidifier manifold to the heating coil (particularly if the heating coil is electric)
- E. POOR: workable if the cooling coil is inactive during humidifier operation. An active cooling coil will remove the moisture the humidifier is trying to put in.
- F. POOR: same problems as C&D plus the air may be very cold, increasing evaporation distance or causing condensation.
- G. POOR: same problems as C, D, & E plus the filters may get wet producing an unsafe condition with growth of biologicals.
- H. POOR: only workable if the system is 100% recirculated air with no exhaust.

The following pages have nomographs and formulas for evaporation distance.

TO DETERMINE THE ULTIMATE STEAM EVAPORATION DISTANCE (ENGLISH):

1. Formula for Calculating Ultimate Steam Evaporation Distance:

The following formula is for approximating evaporation distances (range: 35 - 90°F, 10-99%RH).

$$\frac{(\text{Leaving \%RH} - \text{Entering \%RH}) \times ((\text{duct width} \times \text{duct height}) / (\text{humidifier width} \times \text{humidifier height})) \times ((100 - \text{duct temperature}) / 100)}{}$$

Accordingly, if you have a 48" x 36" humidifier in a 48" x 36" duct with entering condition of 30%RH and leaving condition of 70%RH and duct temperature of 55°F:

$$(70 - 30) \times ((48 \times 36) / (48 \times 36)) \times ((100 - 55) / 100) = 18 \text{ inches evaporation distance}$$

If the actual humidifier was a smaller size (36" x 24" in a 48" x 36" duct):

$$(70 - 30) \times ((48 \times 36) / (36 \times 24)) \times ((100 - 55) / 100) = 36 \text{ inches evaporation distance}$$

Since duct velocity has a self-canceling effect, this formula works on velocities up to 2,000 fpm. Be sure to use accurate entering and leaving conditions at the worst point, i.e.: highest differential.

Nomograph for Determining Ultimate Steam Evaporation Distance:

To use nomograph, move horizontal from the Entering %RH to the vertical intersection of the Leaving %RH. Then move diagonally left and down to the duct intersection of the horizontal temperature line, and horizontal across to the vertical intersection of the Duct temperature.

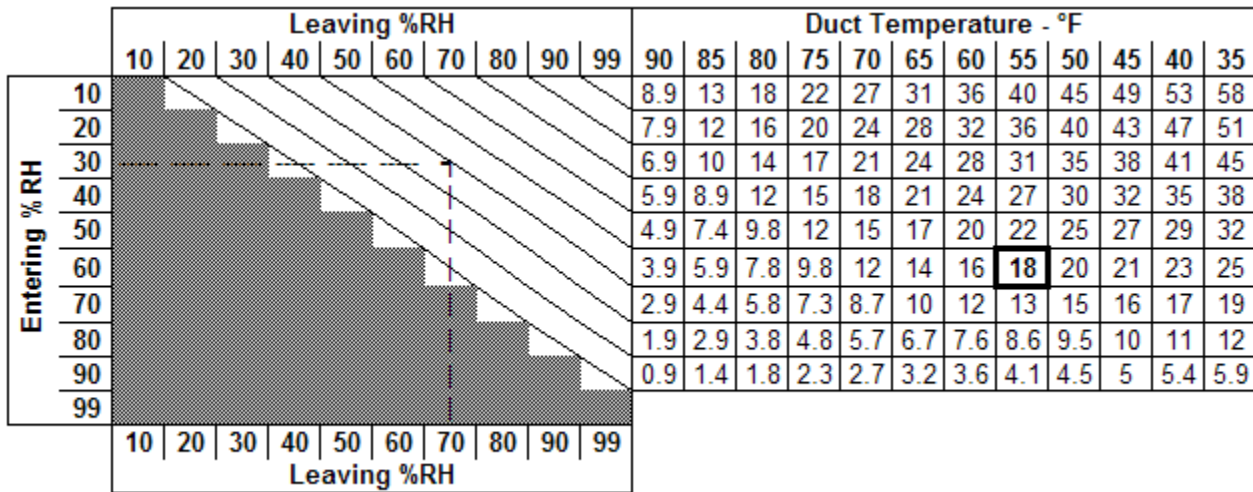

Example: Entering 30%RH, Leaving 70%RH, Temperature 55°F = 18 inches

NOTES:

1. Nomograph assumes an UltimateSteam manifold sized properly to the duct size.
2. Carel considers evaporation distance to be the point where the average droplet size is below 0.5 microns (invisible). "Non-wetting distance" as used by some competitors is undefined.
3. DSO single pipe UltimateSteam units are generally 2 times the above evaporation distances, but adding multiple DSO pipes reduces the evaporation distance by the square.

TO DETERMINE THE ULTIMATESTEAM EVAPORATION DISTANCE (METRIC):

1. Formula for Calculating UltimateSteam Evaporation Distance:

The following formula is for approximating evaporation distances (range: 1 - 32°C, 10-99%RH).

$$\frac{(\text{Leaving \%RH} - \text{Entering \%RH}) \times ((\text{duct width} \times \text{duct height}) / (\text{humidifier width} \times \text{humidifier height})) \times ((100 - (1.8 \times \text{duct temperature} + 32)) / 100) \times 25.4}{1}$$

Accordingly, if you have a 1200mm x 900mm humidifier in a 1200mm x 900mm duct with entering condition of 30%RH and leaving condition of 70%RH and duct temperature of 13°C:

$$(70 - 30) \times ((1200 \times 900) / (1200 \times 900)) \times ((100 - (1.8 \times 13 + 32)) / 100) \times 25.4 = 453\text{mm evaporation distance}$$

If the actual humidifier was a smaller size (900mm x 600mm in a 1200mm x 900mm duct):

$$(70 - 30) \times ((1200 \times 900) / (900 \times 600)) \times ((100 - (1.8 \times 13 + 32)) / 100) \times 25.4 = 906\text{mm evaporation distance}$$

Since duct velocity has a self-canceling effect, this formula works on velocities up to 10 mps.

Be sure to use accurate entering and leaving conditions at the worst point, i.e.: highest differential.

Nomograph for Determining UltimateSteam Evaporation Distance:

To use nomograph, move horizontal from the Entering %RH to the vertical intersection of the Leaving %RH. Then move diagonally left and down to the duct intersection of the horizontal temperature line, and horizontal across to the vertical intersection of the Duct temperature.

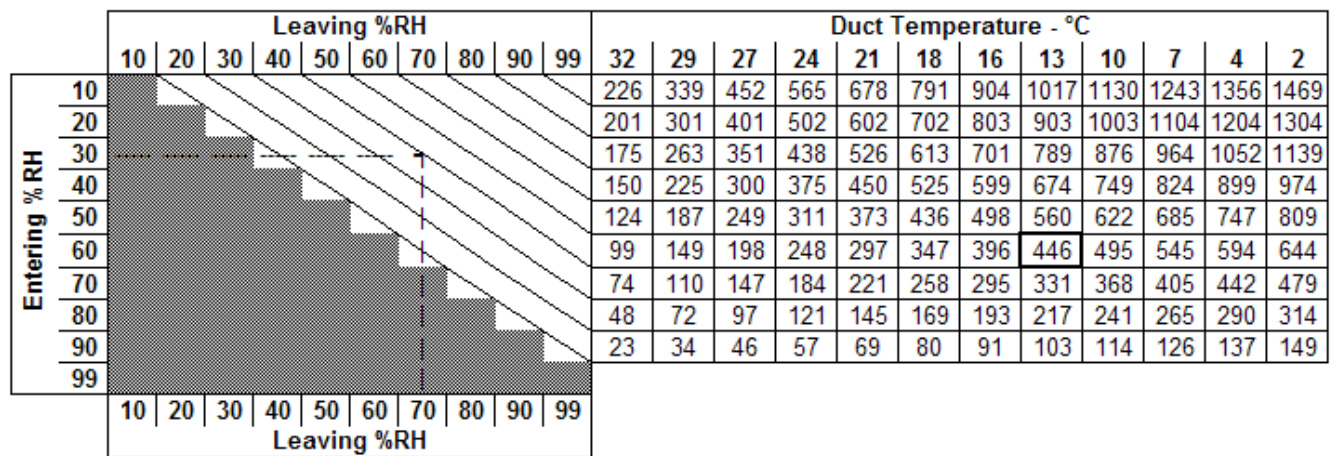

Example: Entering 30%RH, Leaving 70%RH, Temperature 13°C = 446mm

NOTES:

1. Nomograph assumes an UltimateSteam manifold sized properly to the duct size.
2. Carel considers evaporation distance to be the point where the average droplet size is below 0.5 microns (invisible). "Non-wetting distance" as used by some competitors is undefined.
3. D50 single pipe UltimateSteam units are generally 2 times the above evaporation distances, but adding multiple D50 pipes reduces the evaporation distance by the square.

ASSEMBLE AND MOUNT THE ULTIMATESTEAM MANIFOLDS

DSO SINGLE MANIFOLD MODELS

The **DSO** single manifold models do not require any manifold assembly.

Generally the distributor manifolds should be mounted in the center of the air stream. Multiple pipes need to be evenly spaced to cover the duct surface area.

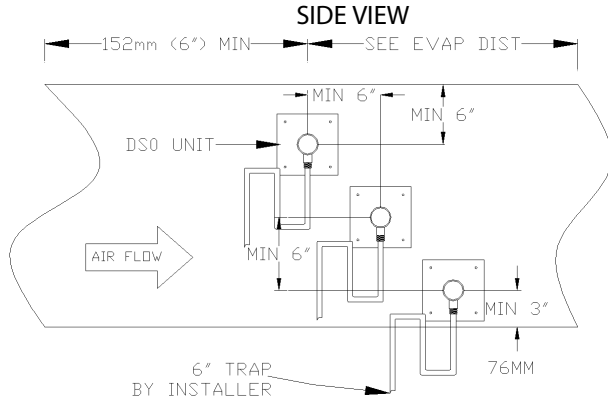

In vertical ducts, the distributor manifolds are mounted in the center with the slots facing up. The airflow may be up or down, but when the airflow is down, maximum velocity is 1,500 fpm (7.6 m/s).

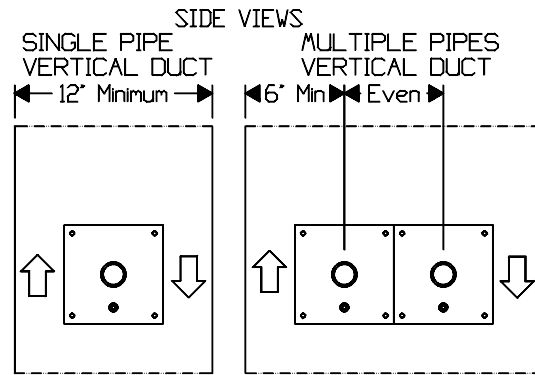

300 mm 150 mm

Installation of the manifold into the duct is simple:

1. Bore a 2-1/2" (63.5 mm) diameter hole in the side of the duct;
2. Caulk the mounting plate facing the duct;
3. Insert the manifold through the hole and secure the mounting plate with sheet metal screws;
4. Secure the opposite end either by piercing the duct with a threaded rod, or by a hanging strap. End mounting stud is 3/8"-16. 12" & 18" (300 & 450 mm) models do not have an end mounting stud) Drain connection is 1/2" MPT.

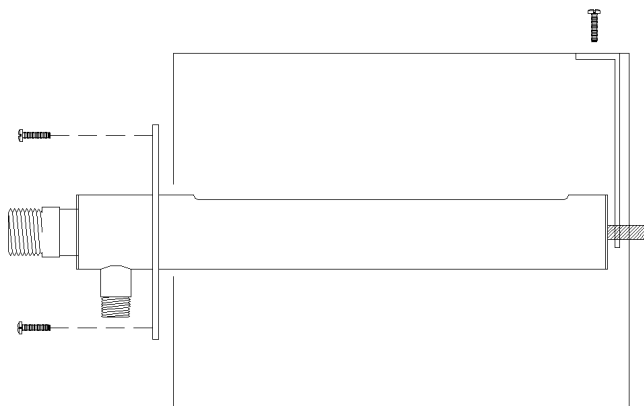
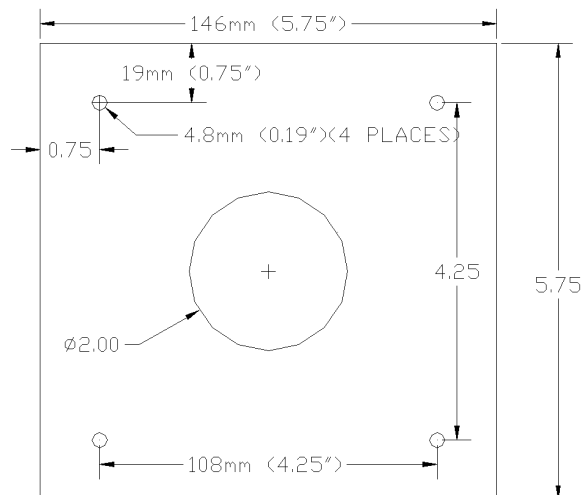

DSB BOTTOM FED MANIFOLD MODELS

Assemble Vertical Manifolds

The vertical distribution manifolds are inserted into the bottom feed header by hand (slip fit) and then into the top header if any.

- Vertical slotted discharge manifolds must be installed with the internal fishbone wick ends sloping up as in a "Y".
- Do not force the vertical manifolds into the headers beyond the insulation.
- Do not use any lubricants. Manually reform the ends slightly if necessary.
- Insure discharge slots are perpendicular to the air flow.
- On DST models, run a bead of RTV silicone caulk around the junction of the vertical manifolds and top header.

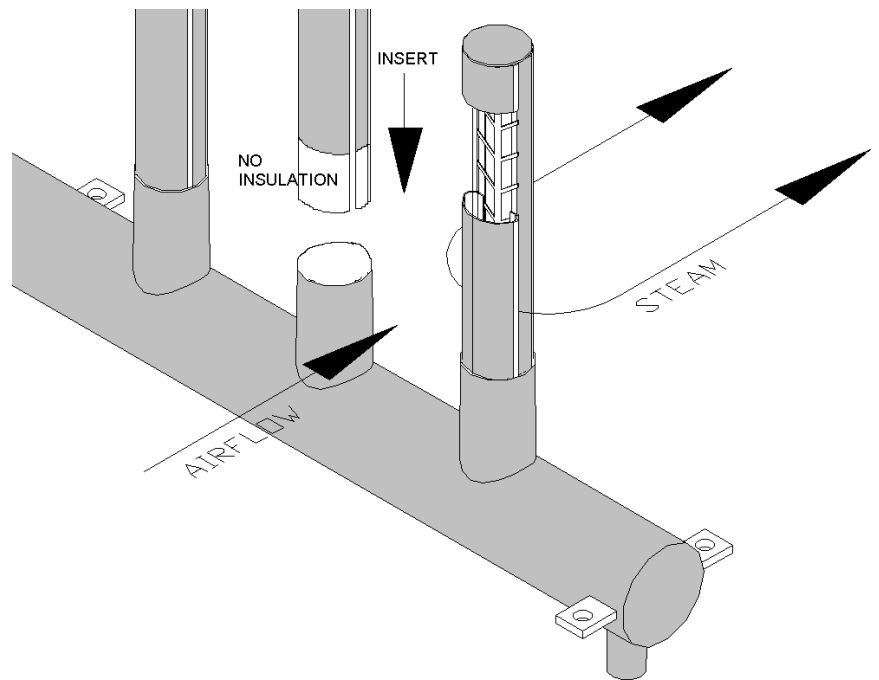

The DSB models have the flexibility of being installed 2 different ways:

1) with the header underneath the duct and only the vertical manifolds in the duct, OR

2) with the entire assembly inside the duct. In air handler installations, clearance must be allowed at the bottom for the steam trap assembly as well as the p-trap draining the header.

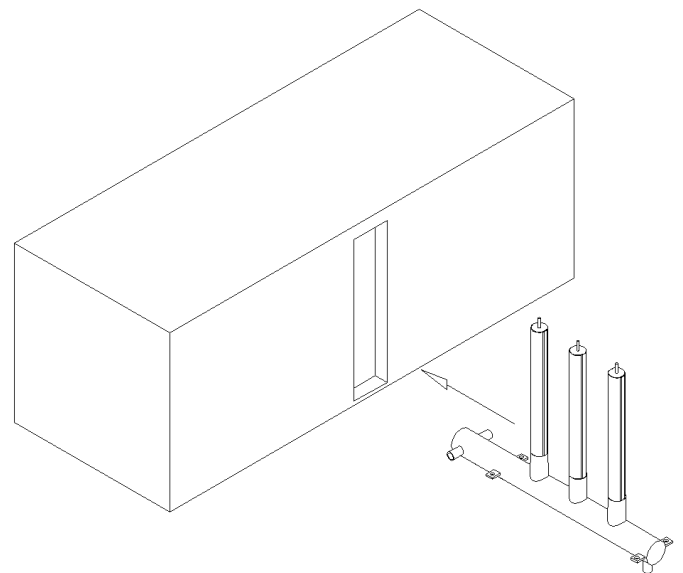
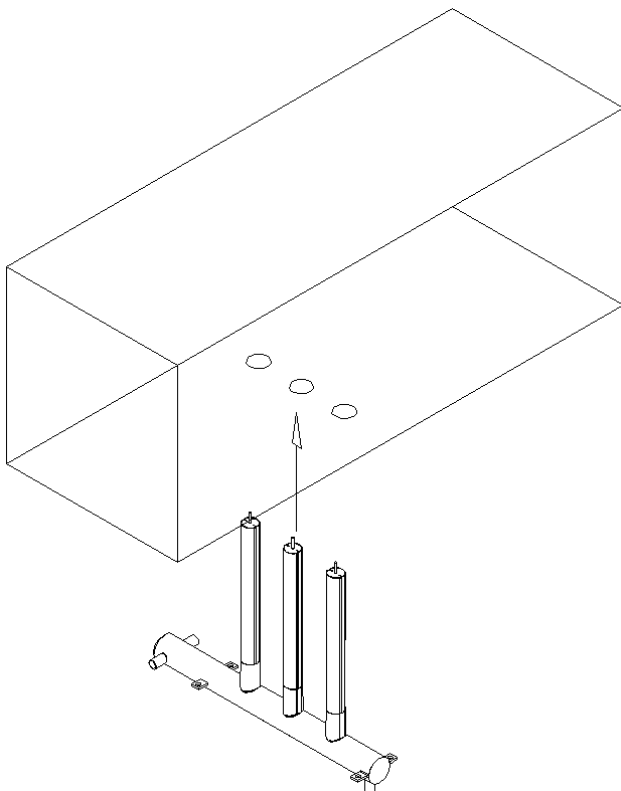

Vertical Upright Insertion

- A** The vertical uprights must be inserted 2.5" to 3" into the collar. A stop has been welded to the upright to prevent over-insertion.

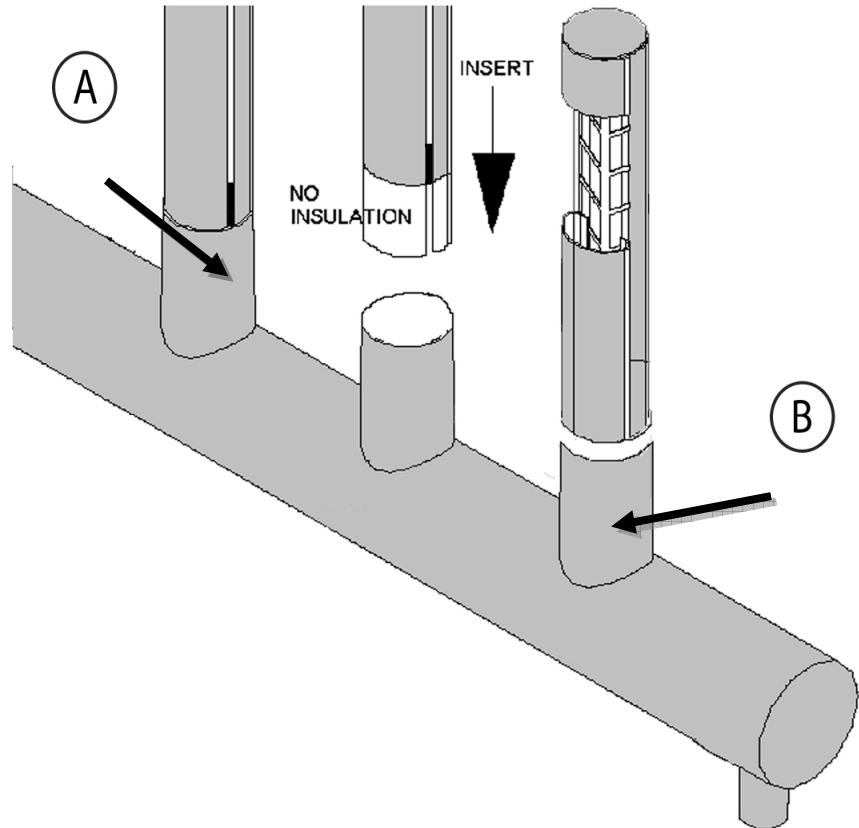

Exposure up to 1/2" of bare metal on the uprights at the collar will not affect the performance of the unit.

- B** For aesthetic purposes, black high temperature RTV silicone can be used to seal the upright to the collar and cover the bare metal.

MOUNTING THE MANIFOLDS

The DSB and DST systems are mounted to the duct or overhead support using bolts or threaded rod through the mounting clamps supplied with the humidifiers.

A top support strap could also be used (for units with height of 36" (900 mm) or more), which fastens across the vertical manifolds and to the duct top or sides. (Strap not supplied by CAREL.)

MAKE SURE HEADER IS LEVEL

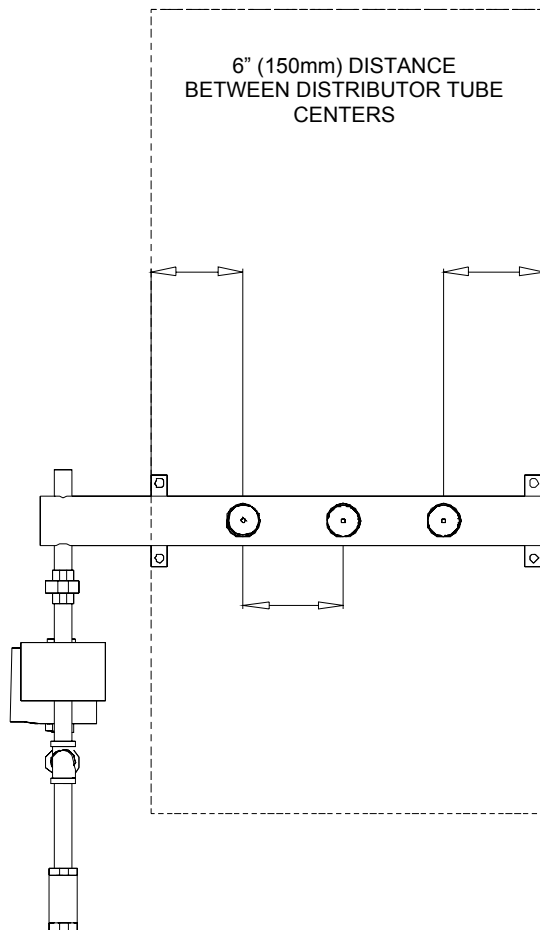

The humidifier is generally installed in ducts so that the end of the header sticks out of the duct on the feed side. In air handlers, the entire assembly will be inside the air handler plenum.

Keep a minimum of 6" (150 mm) from the last vertical discharge manifolds to the sides of the duct or air handler.

INSTALLATION CLAMPS FOR DST & DSB

DST UltimateSteam System contains:
(Qty 4) 4" clamps and (Qty 4) 3" clamps

DSB Ultimate Steam System contains:
(Qty 4) 3" clamps



3" or 4" Clamp

Note: Threaded rod, nuts and other mounting hardware are provided by the installer.

This design allows the UltimateSteam unit to be mounted from the bottom (as shown in the pictures below) or the clamps can be rotated and the unit can be mounted from the face of a coil.

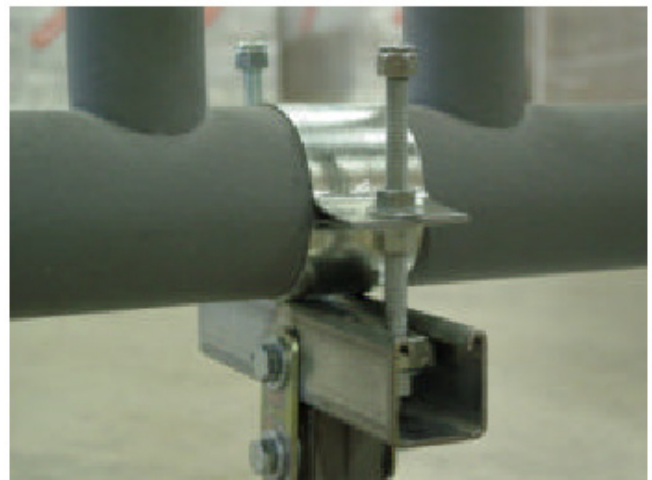
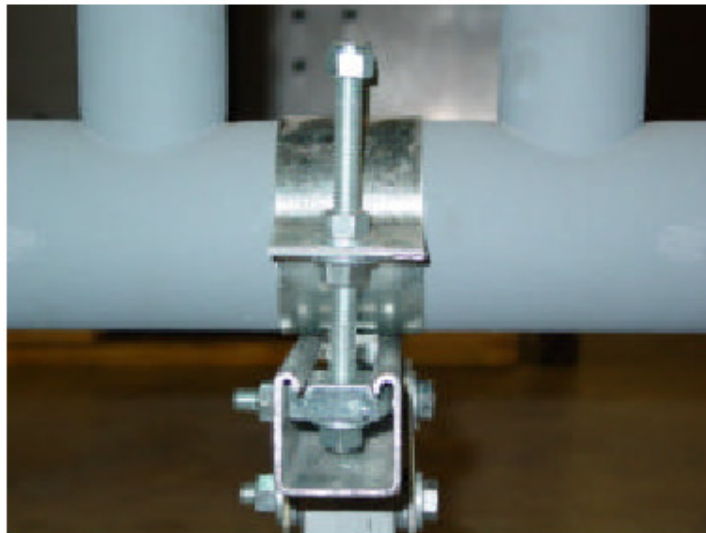

AIR HANDLER MOUNTING

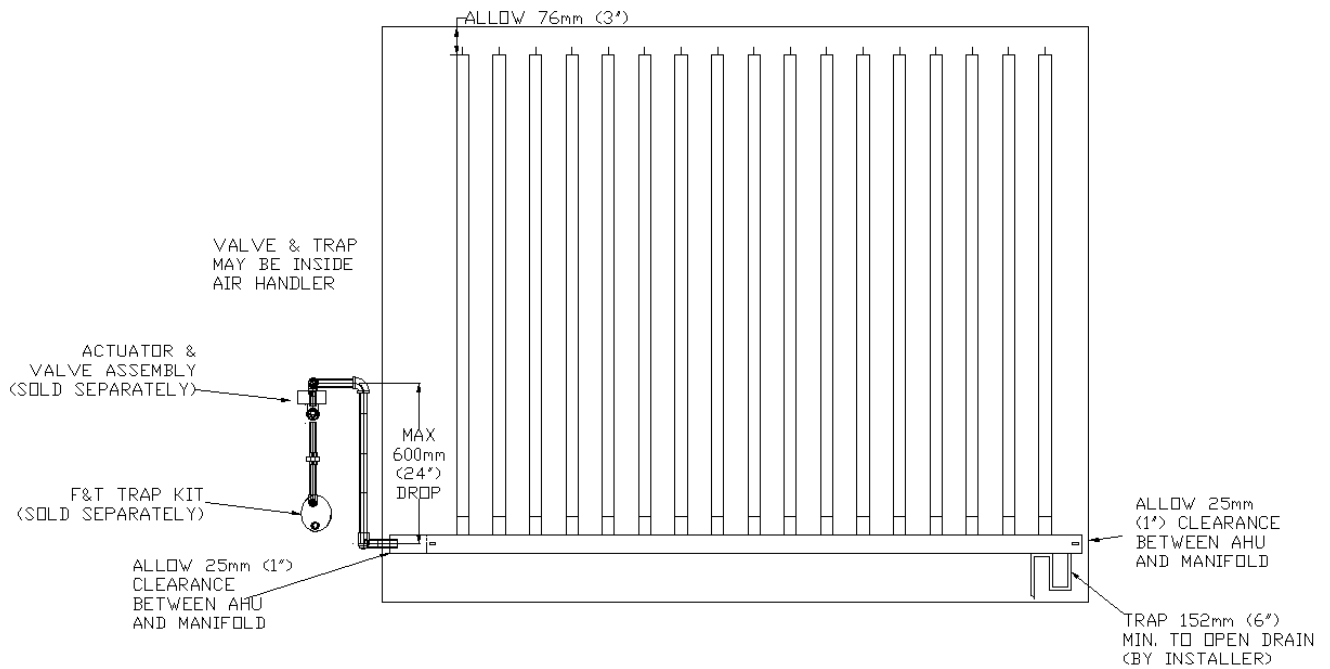

DSB Model

DST TOP-FED MODELS

The **DST** models are assembled inside the duct or air handler if necessary, by mounting the bottom header first, then inserting the upright manifolds, then installing the top header and securing the assembly.

The top and bottom headers are secured, as with the DSB models, either to the plenum top and bottom, or to unistrut or hanging rods. Unit must be secured so that air velocity does not move it.

NOTE: When the vertical upright steam discharge manifolds (slotted) are installed into the top header, you must run a bead of high temperature RTV silicone around the junction to seal it from dripping.

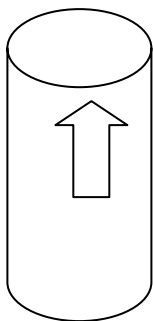
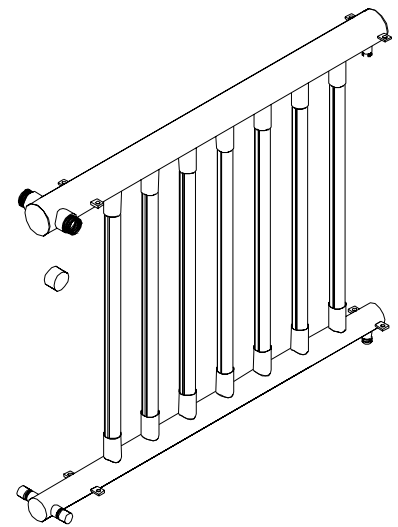

NOTE: When assembling the upright distributors into the bottom and top headers, always insert so that the attached arrow faces UP.

AIR HANDLER INSTALLATION

Installation of the UltimateSteam inside an air handler requires that the system be sized slightly smaller to allow for proper fall to the steam trap and clearances for the valves and actuators.

DST Model

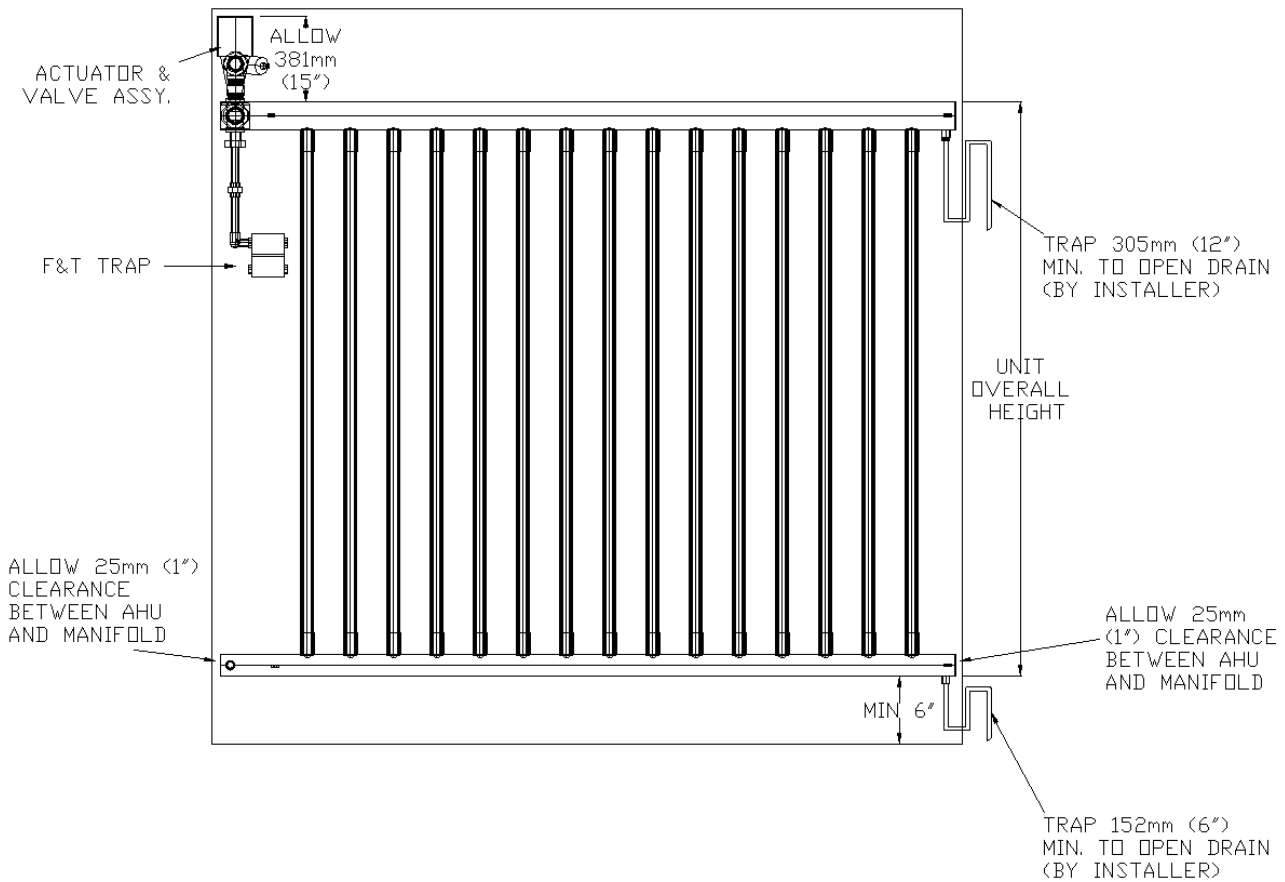

ASSEMBLE CONTROL VALVE ASSEMBLY

DS Valve kits are sold as separate items and include: (shipped unassembled)

Part Number	Description	Components
DSAK24V00A	1/2" valve size CV= 0.4	(2) 1/2" MPT x 3" nipples (2) 1/2" FPT x 1" MPT hex bushings 1" union
DSAK24V00B	1/2" valve size CV= 0.63	(2) 1/2" MPT x 3" nipples (2) 1/2" FPT x 1" MPT hex bushings 1" union
DSAK24V00C	1/2" valve sizes CV= 1	(2) 1/2" MPT x 3" nipples (2) 1/2" FPT x 1" MPT hex bushings 1" union
DSAK24V00D	1/2" valve sizes CV= 1.6	(2) 1/2" MPT x 3" nipples (2) 1/2" FPT x 1" MPT hex bushings 1" union
DSAK24V00E	1/2" valve sizes CV=2.5	(2) 1/2" MPT x 3" nipples (2) 1/2" FPT x 1" MPT hex bushings 1" union
DSAK24V00F	1/2" valve sizes CV=4	(2) 1/2" MPT x 3" nipples (2) 1/2" FPT x 1" MPT hex bushings 1" union
DSAK34V00G	3/4" valve size CV= 6.3	(2) 3/4" MPT x 3" nipples (2) 3/4" FPT x 1" MPT hex bushings 1" union

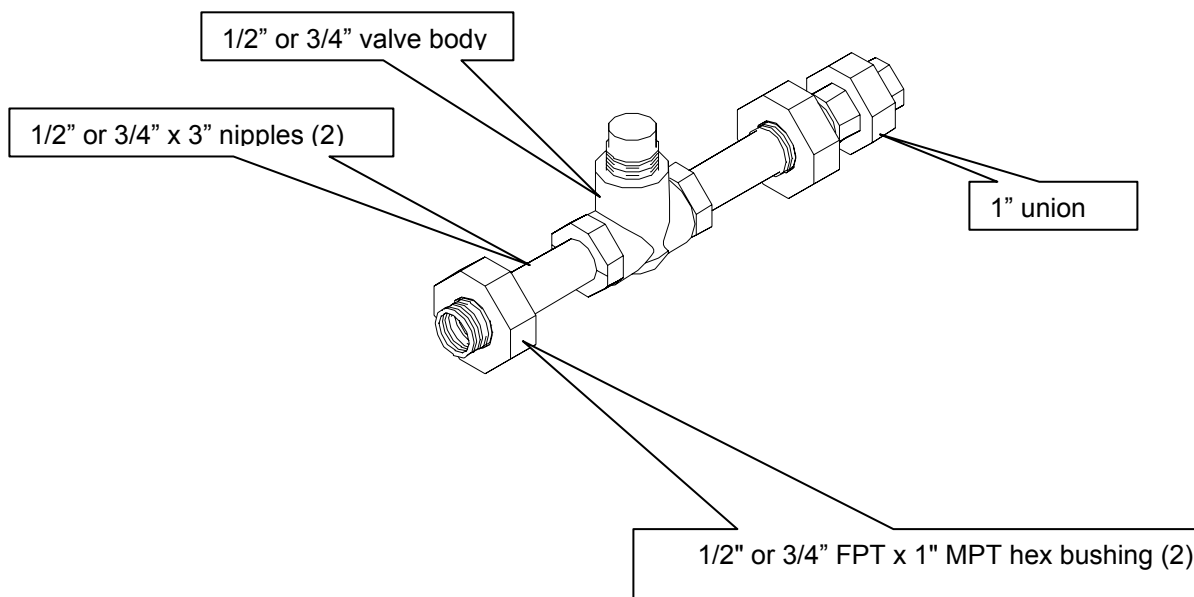

**** NOTE:**

DSAK24V00* = brass body, SS trim, and iron components up to 15 psi

DSAK24VS0* = brass body, SS trim, and iron components up to 15 psi

DSAK24V0H* = bronze body, SS trim, and SS components for 20 to 60 psi

DSAK24VSH* = bronze body, SS trim, and SS components for 20 to 60 psi

Part Number	Description	Components
DSAK44V00H	1" valve size CV=10	(2) 1" MPT x 3" nipples 1" union

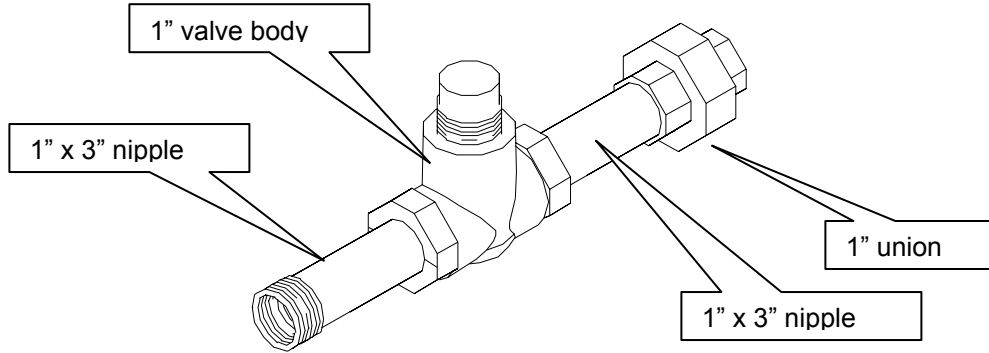

Part Number	Description	Components
DSAK54V00I	1 1/4" valve size CV= 16:	(2) 1-1/4" MPT x 3" nipples (2) 1 1/4" FPT x 2" MPT hex bushings 2" union
DSAK64V00J	1 1/2" valve size CV= 25:	(2) 1-1/2" MPT x 3" nipples (2) 1 1/2" FPT x 2" MPT hex bushings 2" union

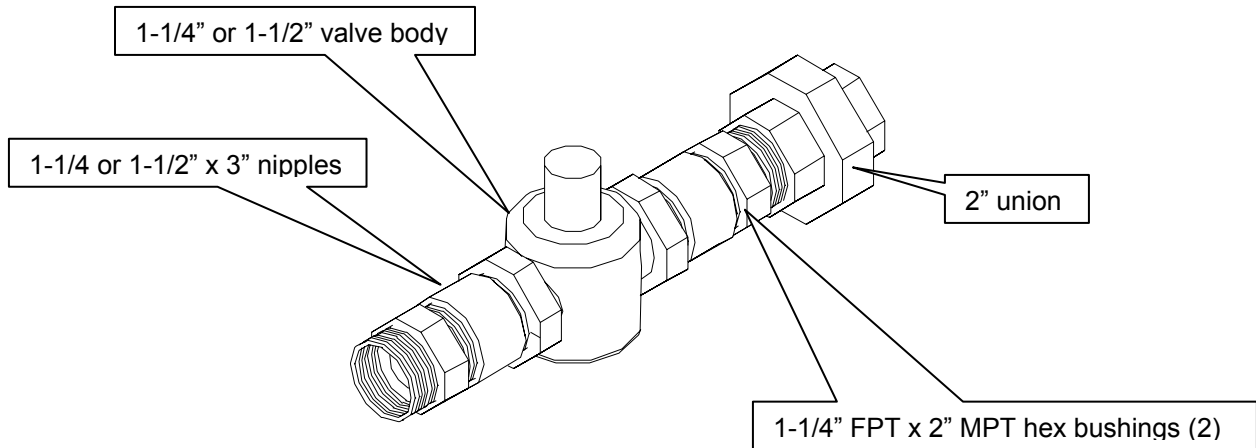

Part Number	Description	Components
DSAK84V00K	2" valve size CV= 40:	(2) 2" MPT x 3" nipples 2" union

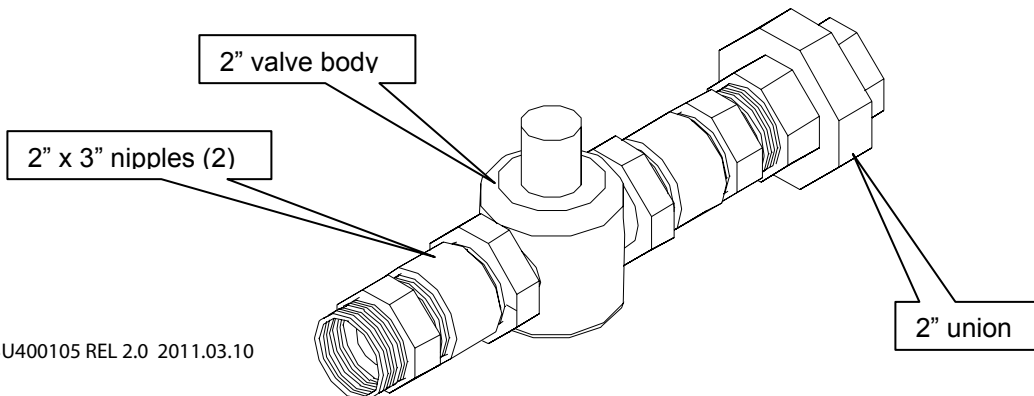

ASSEMBLE STRAINER & TRAP ASSEMBLY AND VALVE ASSEMBLY

Using proper pipe thread sealant, assemble the supplied parts as shown.

1" STRAINER & TRAP ASSEMBLY

Part Number	Description	Components
DSAK44T000 DSAK44TS00 (Stainless steel)	1" Steam trap & strainer with plumbing kit	1" Y-strainer 1" x 6" nipple 1" x 90° FPT elbow 1" x 3" nipple 1" FPT tee 3/4" x 1" hex bushing (2) 3/4" x 6" nipples 3/4" FPT union 3/4" 90° street elbow 3/4" float & thermostatic trap

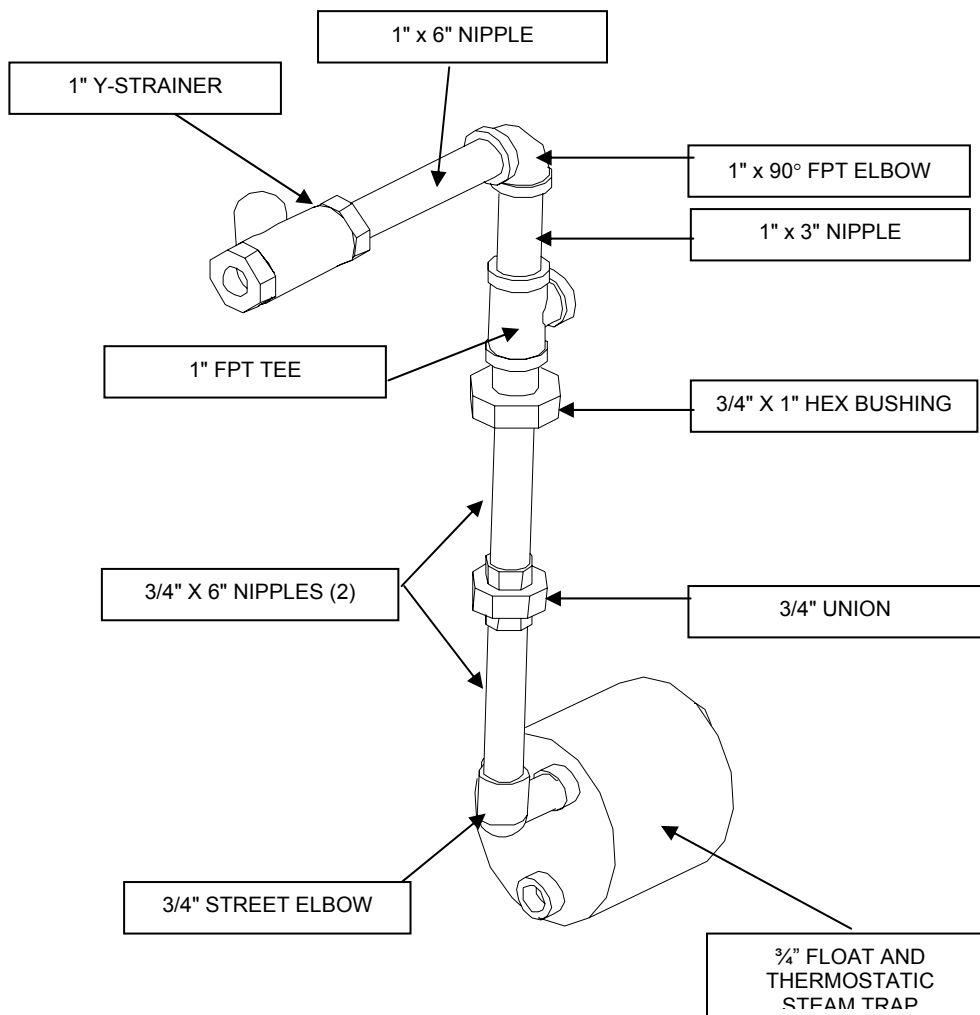

2" STRAINER & TRAP ASSEMBLY

Part Number	Description	Components
DSAK84T000 DSAK84TS00 (Stainless steel)	2" Steam trap & strainer with plumbing kit	2" Y-strainer (3) 2" x 6" nipple (2) 2" x 90° FPT elbow (2) 2" x 3" nipple 2" FPT tee 2" FPT union 2" float & thermostatic trap

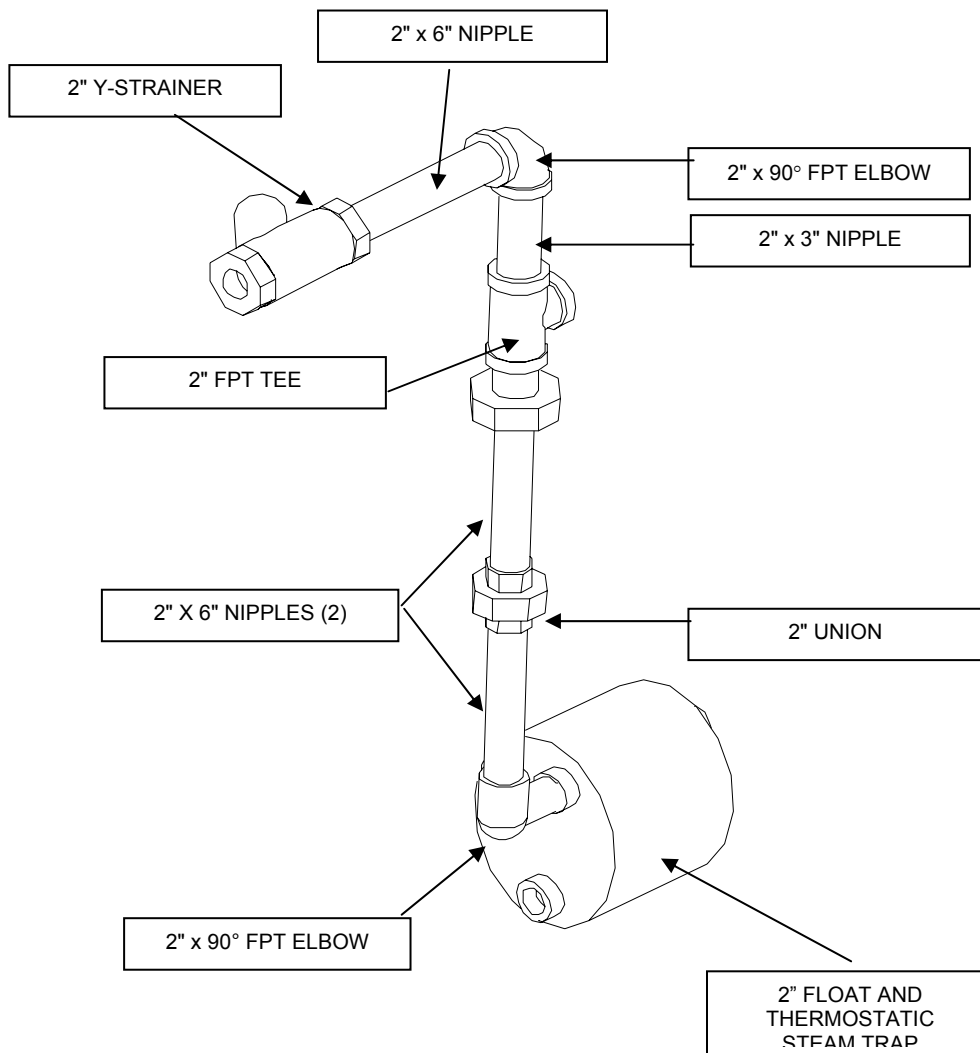

CONNECT CONTROL VALVE & TRAP TO STEAM SUPPLY AND MANIFOLD

DS0 SINGLE MANIFOLD MODELS

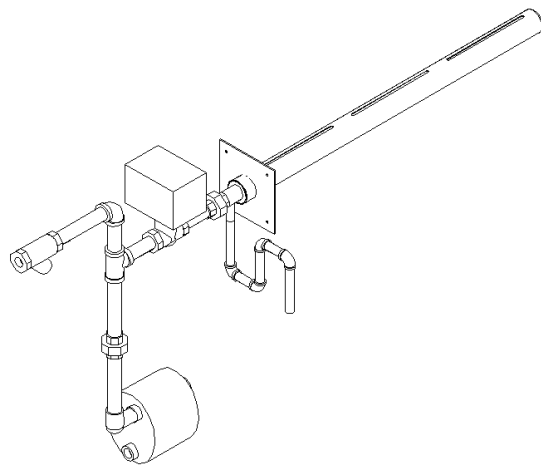

Multiple Single Pipe System

Single Pipe System

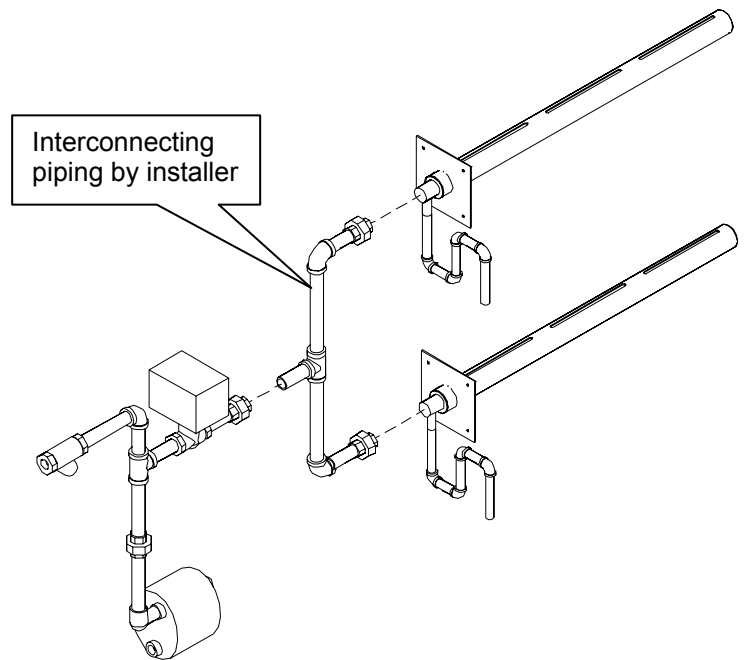

DSB/DST MULTIPLE MANIFOLD MODELS

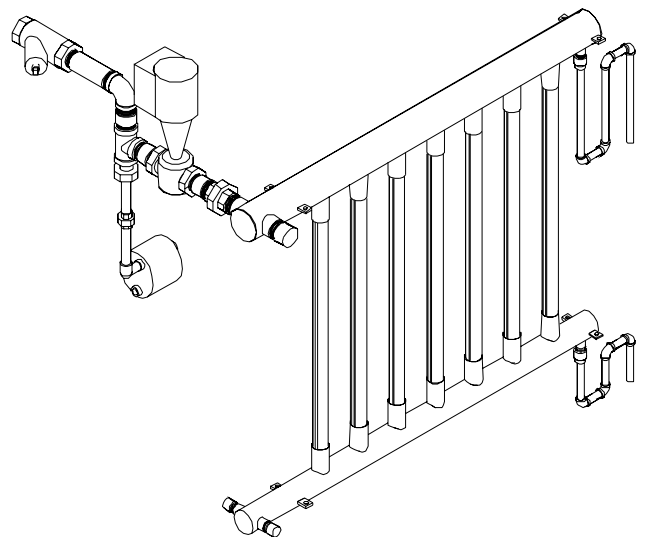
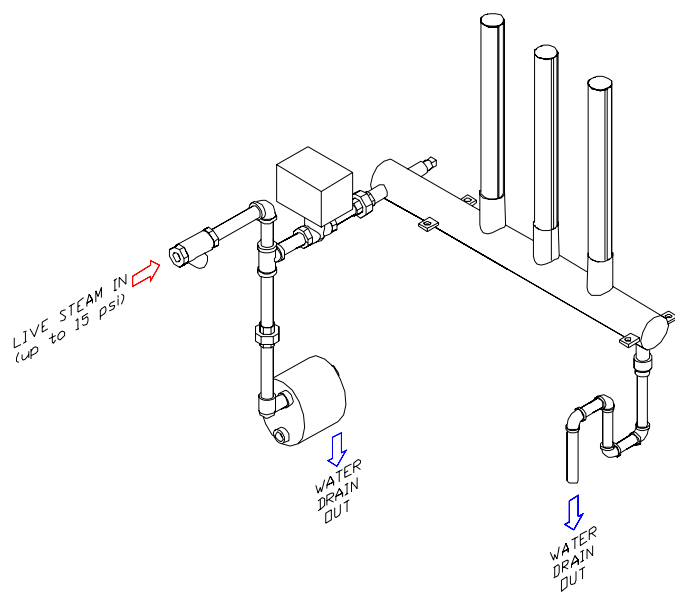

FINAL PLUMBING OF STEAM

SUPPLY AND CONDENSATE DRAINS

Run a steam line from the top of the steam supply header to the inlet strainer on the strainer/valve assembly. Be sure to install an isolation valve in the steam line leading to the humidifier. Follow standard steam piping codes and procedures, maintaining proper slopes.

NOTE: Keep steam control valves as close to the distribution manifolds as possible. CAREL is not responsible for spitting due to excessive piping runs.

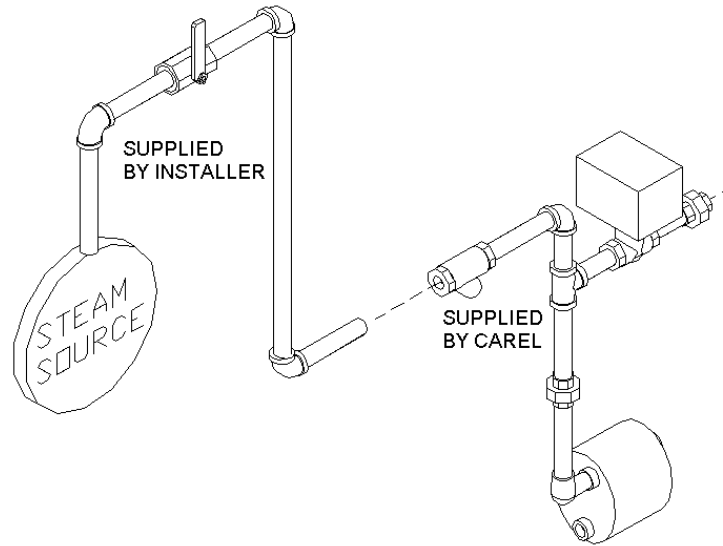

MOUNT VALVE ACTUATOR

THE DSA004E001 ELECTRONIC VALVE ACTUATOR

The DSA004E001 electronic valve actuator is designed to work with the steam control valves to provide proportional control of steam output.



WARNING: If mounting the actuator to a valve already in line, close the valves in the piping (upstream first, then downstream).

Mounting the actuator to the valve:

- 1) Mount the actuator vertically above the valve. Mounting on either side is also acceptable, but *do not mount the actuator upside-down below the valve.*
- 2) If you are attaching the actuator to a new valve, remove the protective plastic cap from the valve stem.
- 3) Place the actuator on the valve.
- 4) Use a 1-1/4 inch open end wrench to tighten the coupling piece.
- 5) Use either a Phillips head screwdriver or a flat blade screwdriver to remove the actuator cover for access to the terminal block, selector plug, and jumper.
- 6) Attach wires, set the selector plug, and remove the R-M jumper, if necessary. Refer to wiring diagrams for your control scheme wiring.
- 7) Place the cover on the actuator. The position indicator must be at the "0" to fit into the shaft. If the cover does not fit easily, rotate it 180 degrees.

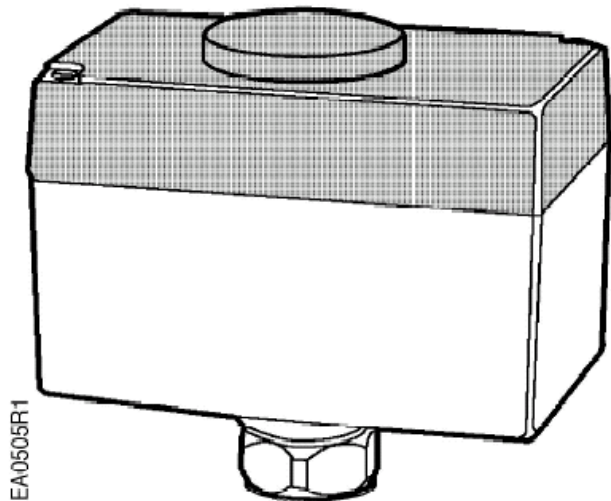

All wiring must conform to NEC and local codes and regulations. **Use earth ground isolating step-down Class 2 transformers. Do not use autotransformers.**

Determine the supply transformer rating by summing the VA of all actuators used. The maximum rating for Class 2 step-down transformer is 100 VA. It is recommended that no more than 10 actuators be powered by one transformer.

To use a 4-20 mA signal, the circuit board jumper between R and M must be cut. If the circuit jumper between R and M is cut, you cannot wire the R and M terminals on the terminal block to re-establish the connection.

THE DSA004E002 ELECTRONIC VALVE ACTUATOR:

Is designed to work with the steam control valves to provide proportional control of steam output.



WARNING: If mounting the actuator to a valve already in line, close the valves in the piping (upstream first, then downstream).

Mounting the actuator to the valve:

- 1) Remove the plastic cover from the top of the valve stem and bonnet.
- 2) Turn the control knob on top of the actuator to the MAN position; the small red tab pops out when in this position. Make sure the yoke nuts are loose enough to allow the actuator to slip over the bonnet.
- 3) Place the actuator onto the valve, putting the valve stem through the bottom of the actuator.
- 4) Guide the valve stem into the stem retainer of the actuator.
- 5) Hold the stem retainer in place as you tighten it around the valve stem.
- 6) Position the actuator to accommodate the wiring. Hold the actuator in place while tightening the yoke nuts.
- 7) Turn the control knob back to the AUTO position.

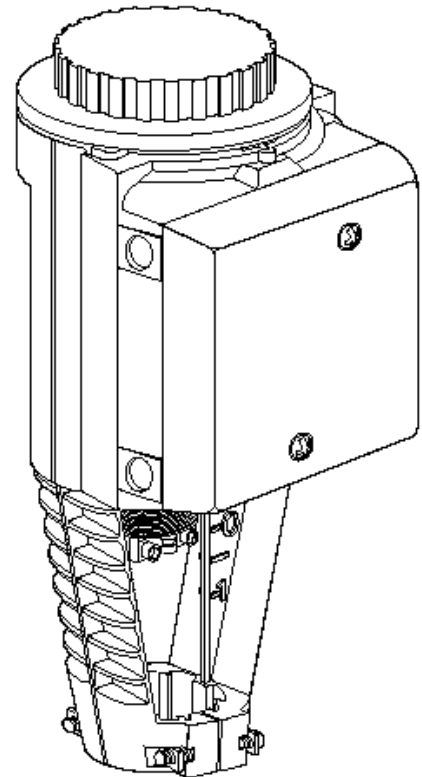

THE DSA004P001 PNEUMATIC VALVE ACTUATOR

The DSA004P001 pneumatic valve actuator is designed to work with the steam control valves to provide proportional control over relative humidity.



WARNING: If mounting the actuator to a valve already in line, close the valves in the piping (upstream first, then downstream).

Mounting the actuator to the valve:

- 1) Remove the cardboard from the retaining ring in the lower housing.
- 2) Place the actuator on the valve bonnet and hand tighten.
- 3) If you need to change the orientation of the actuator, remove the retaining clip in the lower housing and rotate the actuator to the desired position.
- 4) Attach 1/4" (6 mm) poly tubing to the actuator.

(Shown attached to valve)



THE DSA004P002 PNEUMATIC VALVE ACTUATOR

Is designed to work with steam valves from 1 1/4 to 2 inches in size to provide proportional control over humidity.



WARNING: If mounting the actuator to a valve already in line, close the valves in the piping (upstream first, then downstream).

Do not install the actuator upside down:

Mounting the actuator to the valve:

- 1) Remove the cardboard from the retaining ring in the lower housing.
- 2) Place the actuator on the valve bonnet and hand tighten.
- 3) If you need to change the orientation of the actuator, remove the retaining clip in the lower housing and rotate the actuator to the desired position.
- 4) Attach 1/4" (6mm) O.D. poly tubing to the actuator.

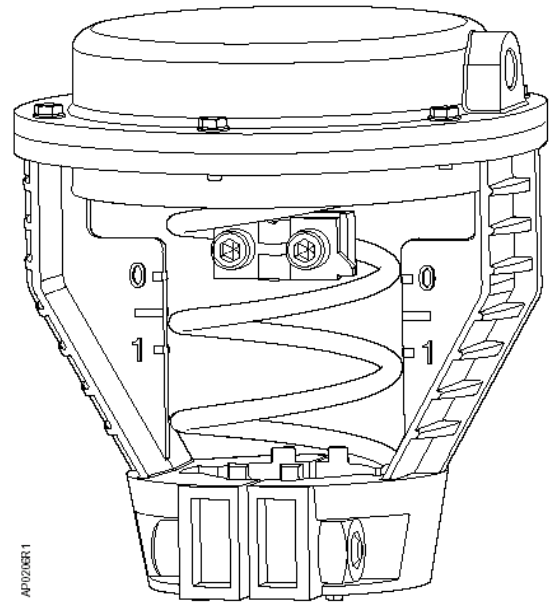

THE DSA004P003 PNEUMATIC VALVE ACTUATOR

Is designed to work with steam valves from 1 1/4 to 2 inches in size to provide proportional control over humidity.



WARNING: If mounting the actuator to a valve already in line, close the valves in the piping (upstream first, then downstream).

Do not install the actuator upside down:

Mounting the actuator to the valve:

- 1) Remove the cardboard from the retaining ring in the lower housing.
- 2) Place the actuator on the valve bonnet and hand tighten.
- 3) If you need to change the orientation of the actuator, remove the retaining clip in the lower housing and rotate the actuator to the desired position.
- 4) Attach 1/4" (6mm) O.D. poly tubing to the actuator.

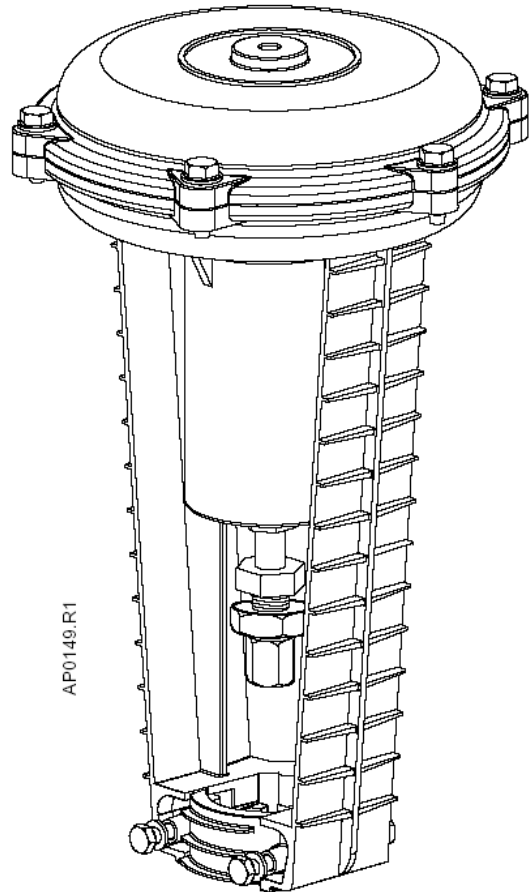

CONTROLS INSTALLATION

A typical humidifier control system includes a wall or return duct sensor or controller, a high limit duct humidistat, and an air proving switch. Placement of these devices is critical to proper operation of the overall system.

The return air RH sensor must always be located BEFORE any outside air intake, in order to insure accurate sensing of the air from the space. Alternatively, a room RH sensor or humidistat can be used. Room sensors should be located on an inside wall or post and should not be hit by any discharge air streams from ducts. In a 100% outside air system, the RH sensor may be placed in the supply duct, at least 10 feet (3 m) downstream of the distributor pipe to act as both hi-limit and control.

The airflow switch must be positioned to accurately open on a loss of air flow, to prevent the humidifier from running when there is no air to absorb the moisture.

The hi-limit humidistat must be positioned far enough downstream of the steam distributor pipe(s) to prevent it from getting wet, but still allow it to accurately prevent over-humidification of the duct that could result in condensation.

Cross Reference of CAREL part numbers to Siemens part numbers:

VALVES							
CAREL Part No. Standard 2-15 psi (0.14-1 Bar)	Siemens Part No. Standard 2-15 psi (0.14-1 Bar)	CAREL Part No. Standard 20-60 psi (1.4-4 Bar)	Siemens Part No. Standard 20-60 psi (1.4-4 Bar)	CAREL Part No. Stainless Steel 2-15 psi (0.14-1 Bar)	Siemens Part No. Stainless Steel 2-15 psi (0.14-1 Bar)	CAREL Part No. Stainless Steel 20-60 psi (1.4-4 Bar)	Siemens Part No. Stainless Steel 20-60 psi (1.4-4 Bar)
DSAK24V00A	599-02015C			DSAK24VS0A	599-02015C		
DSAK24V00B	599-02017C			DSAK24VS0B	599-02017C		
DSAK24V00C	599-02019C	DSAK24V0HC	599-03072C	DSAK24VS0C	599-02019C	DSAK24VSHC	599-03072C
DSAK24V00D	599-02021C	DSAK24V0HD	599-03073C	DSAK24VS0D	599-02021C	DSAK24VSHD	599-03073C
DSAK24V00E	599-02023C	DSAK24V0HE	599-03074C	DSAK24VS0E	599-02023C	DSAK24VSH E	599-03074C
DSAK24V00F	599-02025C	DSAK24V0HF	599-03075C	DSAK24VS0F	599-02025C	DSAK24VSHF	599-03075C
DSAK34V00G	599-02027C	DSAK34V0HG	599-03076C	DSAK34VS0G	599-02027C	DSAK34VSHG	599-03076C
DSAK44V00H	599-02029C	DSAK44V0HH	599-03077C	DSAK44VS0H	599-02029C	DSAK44VSHH	599-03077C
DSAK54V00I	599-03024	DSAK54V0HI	599-03078	DSAK54VS0I	599-03024	DSAK54VSHI	599-03078
DSAK64V00J	599-03025	DSAK64V0HJ	599-03079	DSAK64VS0J	599-03025	DSAK64VSHJ	599-03079
DSAK84V00K	599-03026			DSAK84VS0K	599-03026		
ACTUATORS							
CAREL Part No.	Siemens Part No.						
DSA004E001	SQS65.5U						
DSA004E002	SKD62U						
DSA004P001	599-01088						
DSA004P002	599-01083						
DSA004P003	599-01050						

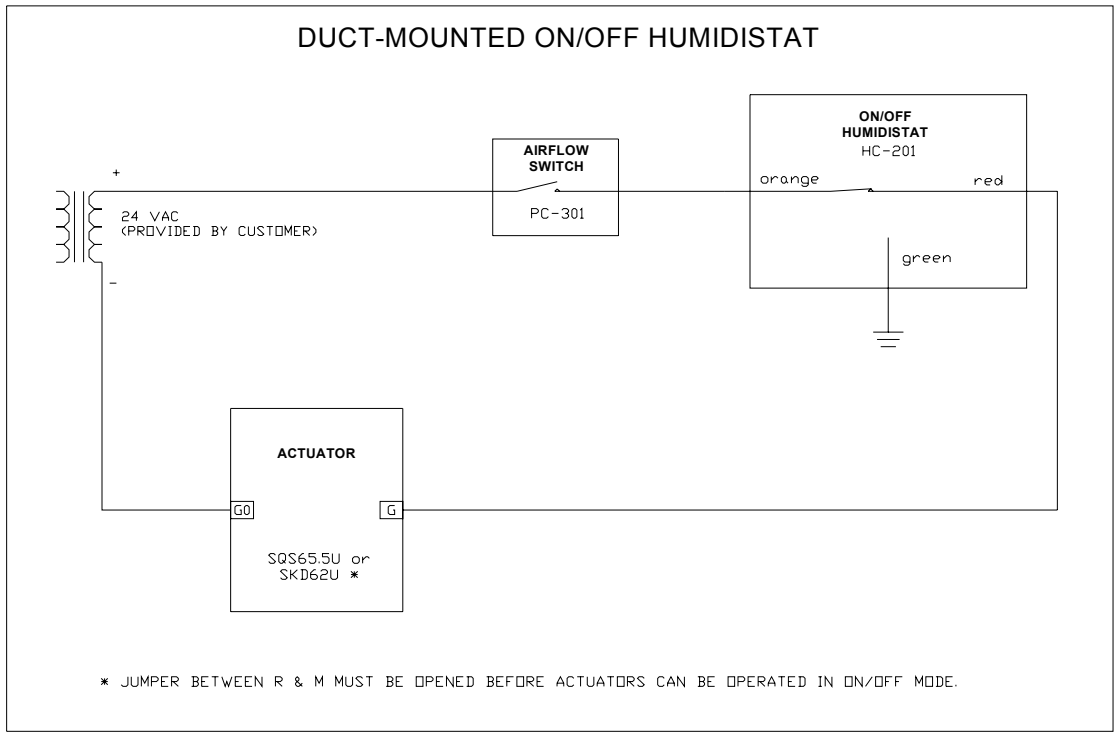
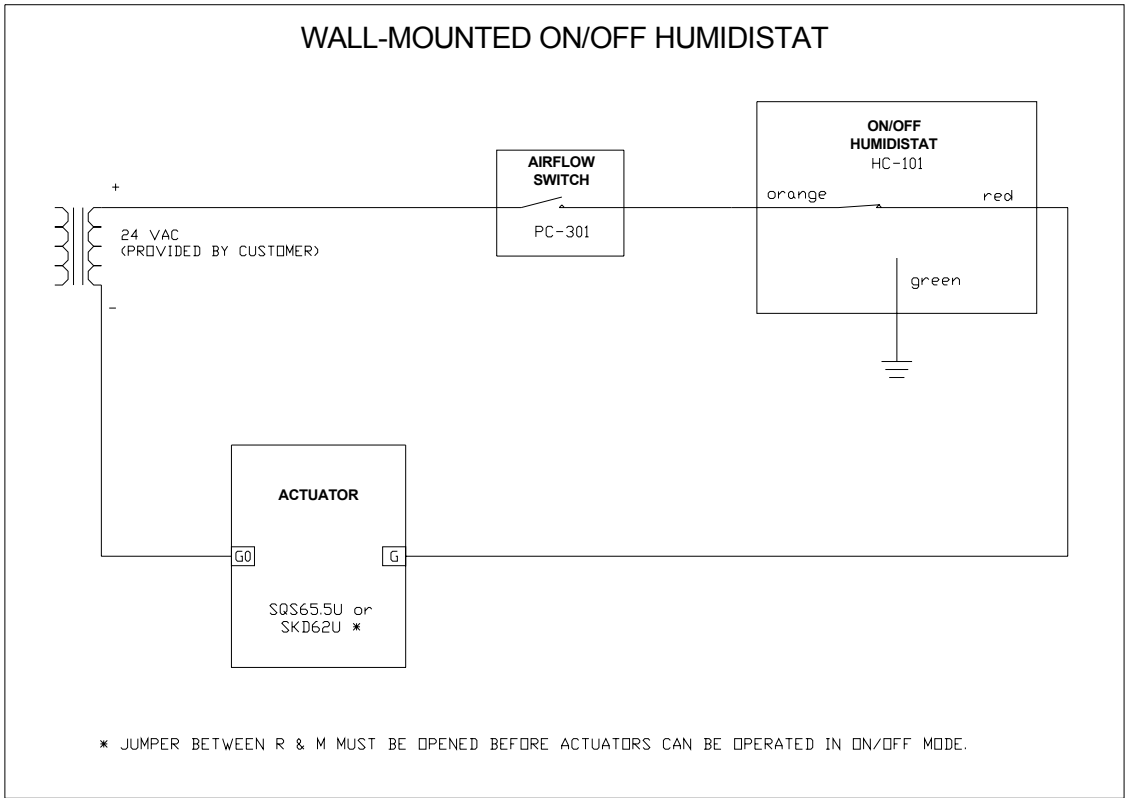

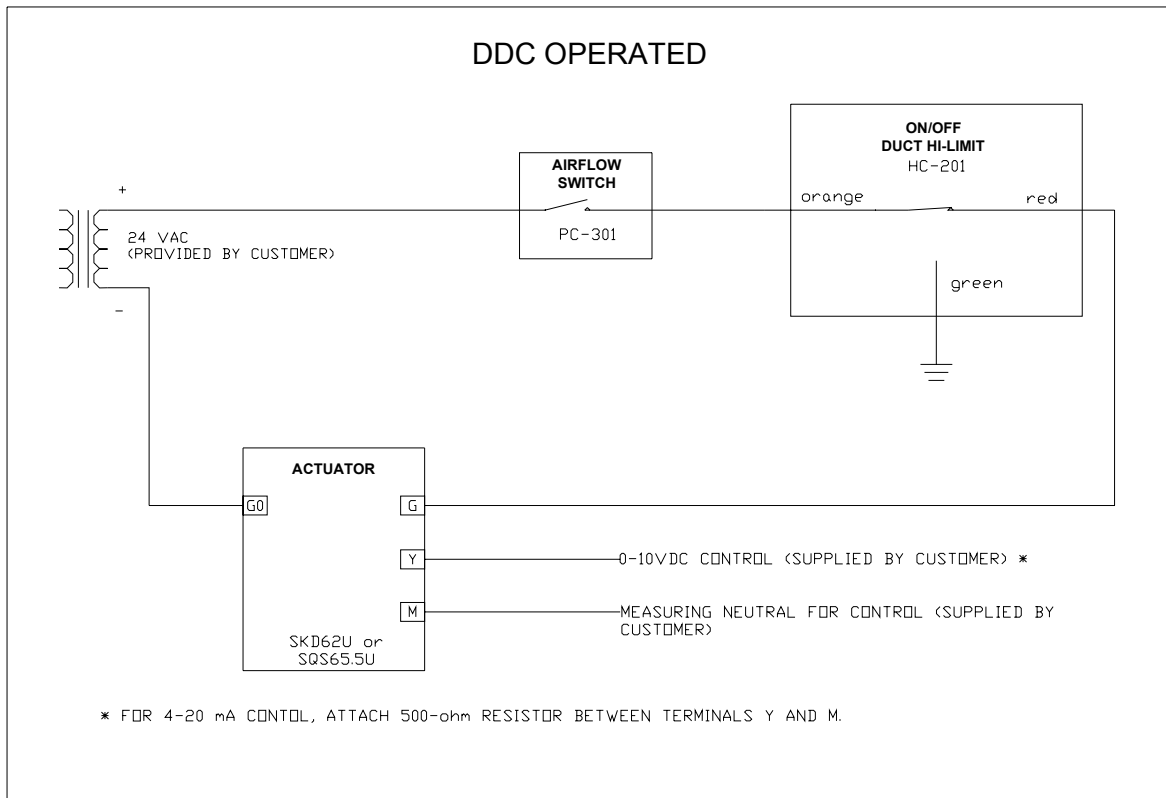

PC-301 Air Proving Switch

Mounting the PC-301 air flow switch:

Mount the airflow switch in the supply or return duct using the screws supplied. Mount the device so that the diaphragm is in a vertical position as shown at right.

If the airflow switch is to be mounted on the return duct (vacuum), then mount it in a vertical position by the small plate. Drill a 7/16" (11 mm) hole in the side of the duct and connect the supplied tubing to the low pressure tap on the airflow switch and then run it through the drilled hole in the duct. Put no more than 2" (50 mm) of tubing into the duct. Caulk around the tubing where it enters the duct. The high-pressure tap is left open to atmosphere.

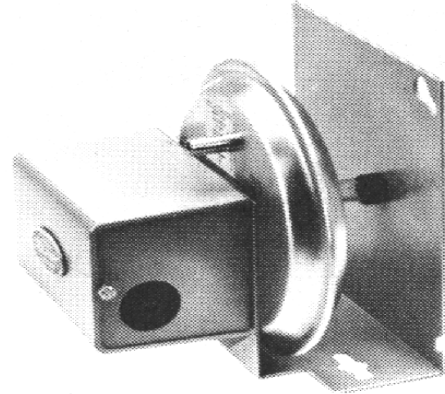

If the airflow switch is to be mounted to the supply duct (pressure), then simply drill a 7/16" (11 mm) hole in the side of the duct, apply caulking to the large plate, and mount the device with the large plate to the duct and the high-pressure tap/tubing mated the hole. The low-pressure tap is left open to atmosphere.

MOUNTING DIAGRAMS (English units)

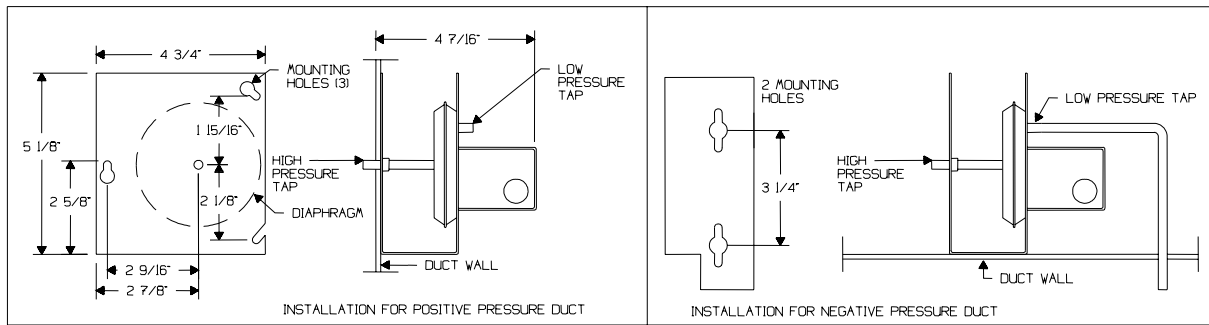
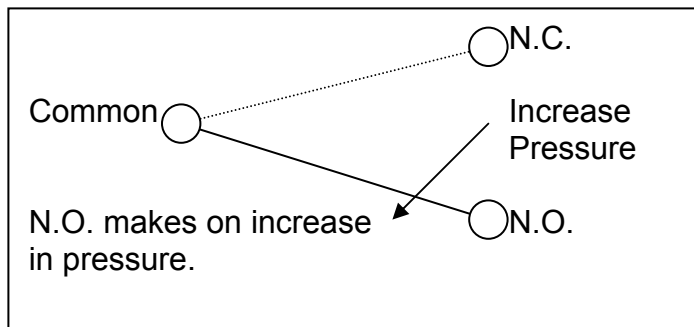

TABLE 1. MAXIMUM ELECTRICAL SWITCH RATINGS

Vac	Full Load Amps	Locked Rotor Amps	Pilot Duty (VA)	Non-Inductive Amps
24V	-	-	60	10
120V	6.25	37.5	300	10
240V	3.1	18.6	300	10
277V	2.7	16.2	300	10

WIRING DIAGRAM



HC-101 and HC-201 Wall and Duct ON/OFF Humidistat

Mounting the HC-101 room humidistat: Mount the HC-101 humidistat to an inside wall or post in the area to be humidified. Position it so that no drafts from registers or outlets are blowing on it. Be sure that it is not placed over a device that could generate heat or vapor i.e.: stove, machinery, cleaning vat. The unit has three wire leads, Orange, Brown and Red. Use the Orange and Brown leads for control operation. Use the Orange and Red leads for hi-limit operation.

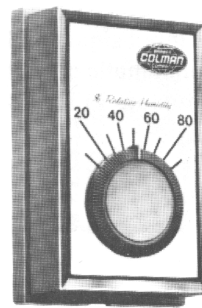

HC-101

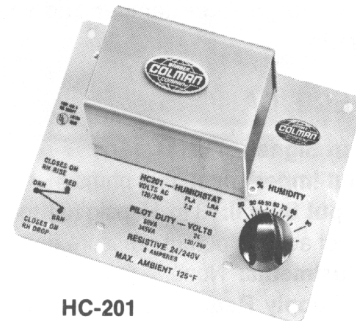

HC-201

Mounting the HC-201 duct humidistat: Cut a hole in the side of the duct and mount the HC-201 humidistat to the duct, using the screws provided, at least 6 feet downstream of any live steam or mist. The unit has three wire leads, Orange, Brown and Red. Use the Orange and Brown leads for hi-limit operation.

Wiring Diagram

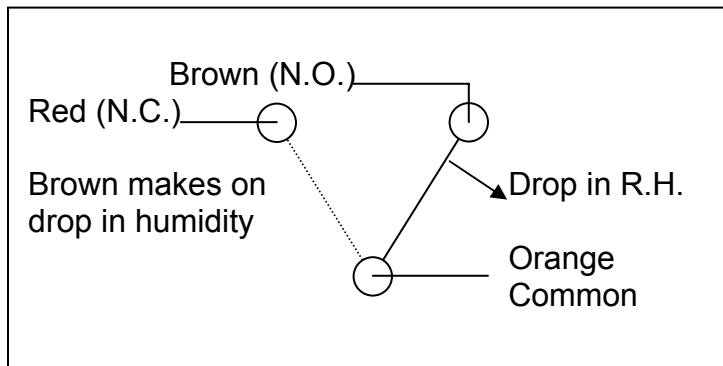

TABLE 1. SPECIFICATIONS

Part No.	Type	Scale Range %RH	Diff. %RH	Operating Limits °F (°C)	Shipping & Storage °C (°F)	Connection	Cover	Dimensions mm (in.)
HC-101	Wall	10 to 90	5	40 to 125 (4 to 2)	-40 to 140 (-40 to 60)	6" (150 mm) color coded leads	Beige plastic	4-3/8 x 2-7/8 x 1-5/8 111 x 73 x 41
HC-201	Duct	15 to 95	5	40 to 125 (4 to 2)	-40 to 140 (-40 to 60)	Coded screw terminals	Metal	4-3/4 x 6-1/2 x 2-1/4 121 x 165 x 57

TABLE 2. MAXIMUM ELECTRICAL RATINGS

Part No.	AC Volt 50/60 Hz	FLA	LRA	Resistive Amps	Pilot Duty VA
HC-101	24	-	-	8	60
HC-201	120	7.2	43.2	8	345
	240	3.6	21.6	8	345

INSTALLATION CHECKLIST

- _____ 1. Humidifier properly assembled with all discharge slots facing the proper direction.

(Multipipe systems have the vertical slots in line with the manifolds, 90° to the air flow. Single pipe systems always have the slot facing up on top.)
- _____ 2. Humidifier headers secured and level.
- _____ 3. Humidifier upright discharge manifolds plumb.
- _____ 4. Valve and trap assembly properly assembled and connected to the humidifier header.
- _____ 5. P-trap installed on discharge of each header.
- _____ 6. Steam feed line properly run, sloped and connected to the valve and trap assembly inlet.
- _____ 7. Controls properly wired.

3. STARTUP

1. Slowly open the steam isolation valve from the steam supply line. You should be able to hear steam running through the valve. Wait a few minutes for the steam to heat up the entire line to the humidifier and for all condensate to clear through the trap.
2. Verify that the steam trap on the valve/trap assembly of the humidifier is working properly - condensate discharge line should be hot.
3. With air flowing in the duct or air handler, create a humidification demand by increasing the humidity control set point until it exceeds the actual humidity reading.
4. The valve on the humidifier should begin to open and steam should enter the humidifier manifolds.
5. Initially most of the steam will condense as it heats the manifolds. Insure that the P-traps on the manifolds are clear and running to drain without leaking steam. NOTE: On first startup, some steam may leak from the P-traps on the manifolds if they have not been primed (filled with water).
6. Steam should begin exiting the humidifier manifolds.
7. Return the humidity control set point to the desired level.

Startup is complete.

4. OPERATION

The operation of the humidifier is simply to discharge steam into the duct or air handler as permitted by the opening and closing of the control valve. Control of the valve is from either the supplied humidistats and controls or from the Building Automation System.

5. MAINTENANCE

There is no maintenance on the humidifier manifold itself.

Follow maintenance instructions for the control valve and actuator, supplied with those devices.

Follow maintenance instructions for the traps, supplied with those devices.

6. TROUBLE-SHOOTING

Water is spitting from the discharge manifolds.

1. The steam trap on the valve/trap assembly is not functioning. Clean or replace.
2. The header P-traps are not draining. Clean and check plumbing - must run to gravity drain. Check that height of trap exceeds the static pressure of the duct/AHU, especially if under negative pressure.
3. The steam line has been taken from the bottom of the steam source or is not sloped properly. Change line to take off from the top and check proper slopes.
4. The steam main is overloaded with water. Locate cause and correct.
5. Vertical discharge manifolds are not plumb. Make plumb.
6. Horizontal headers are not level. Make level.
7. Vertical discharge manifolds are installed upside down. Reinstall correctly.
8. Check valve sizing to maximum manifold capacity. Resize valve within manifold capacity.

Steam does not discharge from the manifolds when the valve is open.

1. Verify that valve is open. Correct.
2. Verify that steam is available and valves are open. Correct.
3. Verify that the steam pressure has not changed. Too high pressure could jam the valve.
4. Carefully place a mirror or metal object close to one of the steam discharge slots. If it fogs, steam is discharging, but evaporating very quickly. No problem. **DO NOT EVER PLACE YOUR HAND OVER OR NEAR THE STEAM DISCHARGE SLOTS.**
5. Y-strainer may be clogged. Clean or replace.

Steam valve will not open.

1. Verify power or air pressure to the valve actuator. Correct.
2. Verify control signal or pressure range to the valve actuator. Correct.
3. Verify control signal polarity to the valve actuator. Correct.
4. Remove actuator and test to see if it operates. Valve may be jammed - clean or replace.
6. Verify that the steam pressure has not changed. Too high pressure could jam the valve.
7. Verify proper valve orientation - electric valves must face up.

Steam valve will not close.

1. Verify control signal to the valve actuator. Correct.
2. Verify control signal polarity to the valve actuator. Correct.
3. Remove actuator and test to see if it operates. Valve may be jammed - clean or replace.
4. Verify that the steam pressure has not changed. Too high pressure could jam the valve.
5. Verify proper valve orientation - electric valves must face up.

Steam valve is leaking.

1. Verify full range control signal to the valve actuator. Correct.
2. Verify control signal polarity to the valve actuator. Correct.
3. Remove actuator and test to see if it operates. Valve may be jammed - clean or replace.
4. Verify that the steam pressure has not changed. Too high pressure could jam the valve.

Humidity exceeds set point.

1. Verify full range control signal to the valve actuator is compatible. Correct.
2. Verify control signal polarity to the valve actuator. Correct.
3. Check calibration of controller. Correct.
4. Insure humidity sensors are installed correctly and not located in drafts (wall). Correct.
5. Remove actuator and test to see if it operates. Valve may be jammed - clean or replace.
6. Verify that the steam pressure has not changed. Too high pressure could cause valve to leak.
7. Verify stable boiler pressure. Wide swings in pressure could be fighting the humidity controls.
8. From BAS system, change to P type control (not PI or PID).

Humidity remains below set point.

1. Verify full range control signal to the valve actuator is compatible. Correct.
2. Verify control signal polarity to the valve actuator. Correct.
3. Check calibration of controller. Correct.
4. Insure humidity sensors are installed correctly and not located in drafts (wall). Correct.
5. Remove actuator and test to see if it operates. Valve may be jammed - clean or replace.
6. Verify that the steam pressure has not changed. Too high pressure could jam valve. Too low will not meet capacity.
7. Verify stable boiler pressure. Wide swings in pressure could be fighting the humidity controls.
8. From BAS system, change to P type control (not PI or PID).
9. Check that air flow switch is not fluttering. Correct.
10. Check that hi-limit controller is not located too close to steam discharge manifolds. Correct.
11. Humidifier is undersized. Check humidity load calculations.

Condensate in duct.

1. Verify humidifier capacity versus air volume.
2. See first item in trouble-shooting section of this manual.
3. Verify that hi-limit controller is working. Correct.
4. Verify evaporation distance to obstructions or elbows. Correct.
5. Verify steam valve is not leaking. Correct.
6. Uninsulated duct may be running through an area where ambient temperature is below internal duct dew point. Insulate duct externally.

Steam leaks from P-traps.

1. Check that height of trap exceeds the static pressure of the duct/AHU, especially if under negative pressure. Correct.
2. Check valve sizing to maximum manifold capacity. Resize valve within manifold capacity.
3. Check that inlet steam pressure does not exceed what the humidifier was ordered for.

7. TECHNICAL SPECIFICATIONS

Distributor Construction: Type 316 Stainless Steel

Insulation: Proprietary high R value pliable coating, plenum safe, non-toxic

Maximum temperature: 500°F (260°C)

Maximum manifold pressure: 1 psi (6.9kpa)

Control valves (standard = brass body, SS trim, and iron components up to 15 psi):

Electric: Siemens or other, full pressure drop

Pneumatic: Siemens or other, full pressure drop

(Carel uses Siemens valves as standard with maximum 15 psi (1 bar) inlet pressure

Steam traps: float & thermostatic standard, inverted bucket when inlet pressure exceeds 15 psi (1 bar)

(Carel uses Barnes & Jones traps as standard) (Standard components are black iron)

NOTE: high pressure components are by special order only.

8. LIMITED WARRANTY

All products manufactured by Carel USA, LLC are warranted to the original purchaser to be free from defects in materials and workmanship in the course of normal and reasonable use for a period of 2 years and 1 month from the date of shipment (The OEM controls warranty is 2 years from date of manufacture), humidifier replacement parts warranty is 90 days from date of Invoice. Warranty replacement parts are warranted for remainder of original unit warranty or 90 days, whichever is longer, so long as the product has been installed and operated in accordance with all appropriate manuals and wiring diagrams, and started up by a qualified Carel USA technician. Any product or part that is found to be defective will, at the option of Carel USA, LLC be replaced or repaired. Carel USA, LLC reserves the right to inspect any part or installation before replacing or repairing defective parts. After startup of the product, labor for repairs or replacement of parts is not covered by this warranty. Products not included in this warranty are NTC and PTC probes, transformers (TRA series), and routinely replaceable parts such as steam cylinders and gaskets. Carel USA, LLC assumes no liability for consequential or inconsequential damage, or damage due to negligence or improper use. Under the terms of this warranty, the original purchaser may have certain legal rights and other rights, which may vary from state to state. The Warranty will not be considered valid if a product is damaged due to negligence, mishandling or misapplication, or if the product label is missing. Carel USA will attempt to repair or replace the products within two (2) months of the receipt of the returned goods.

CAREL USA

385 S. Oak Street
Manheim, PA 17545
Phone: (800) 344-4649
Fax: (717) 664-0449
Email: sales@carelusa.com
Website: www.carelusa.com