

Inline Terminal: ILT AI/TEMP4 RTD

Device Description

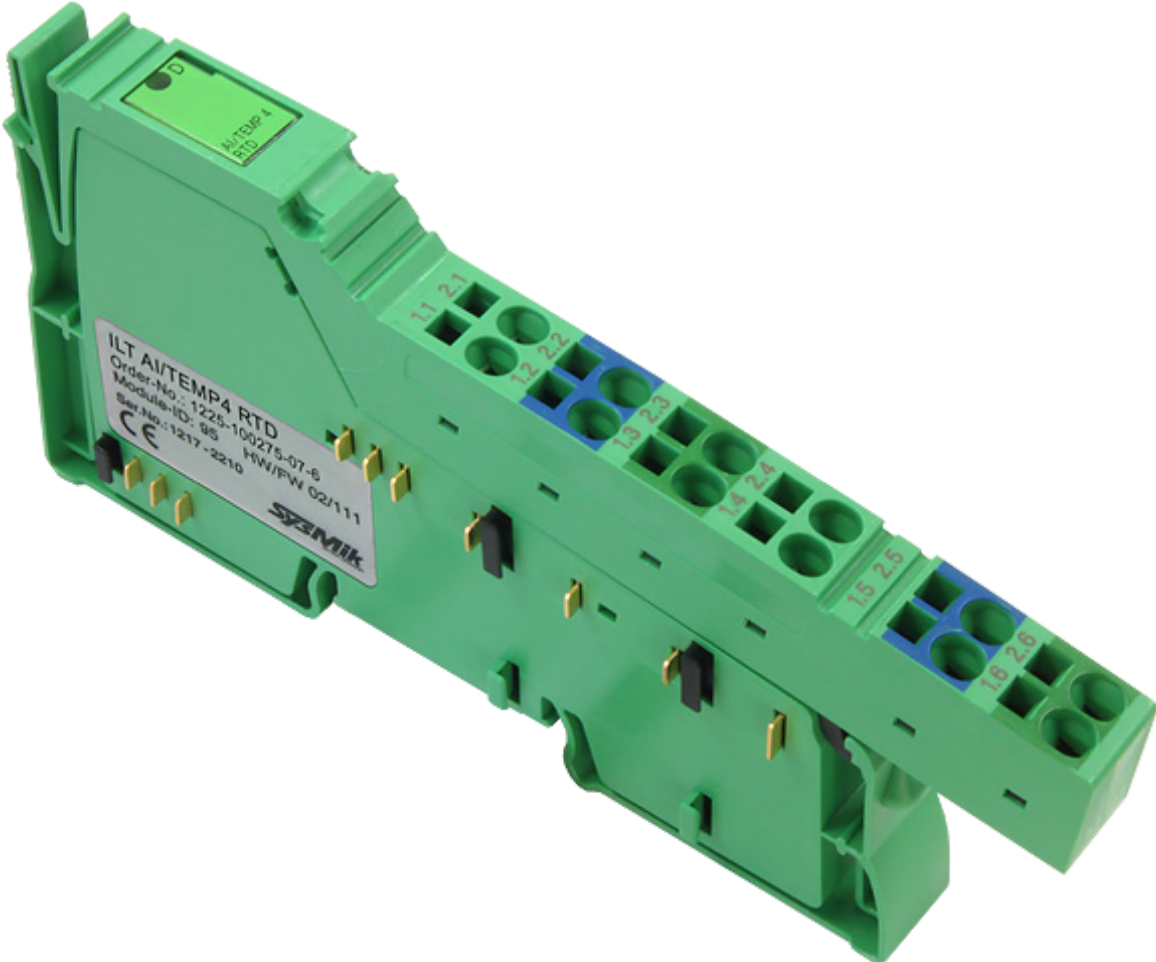

This manual is intended to provide support for installation and usage of the device. The information is believed to be accurate and reliable. However, SysMik GmbH Dresden assumes no responsibility for possible mistakes and deviations in the technical specifications. SysMik GmbH Dresden reserves the right to make modifications in the interest of technical progress to improve our modules and software or to correct mistakes.

We are grateful to you for criticism and suggestions. Further information (device description, available software) can be found on our homepage www.sysmik.de. Please ask for latest information.

SysMik disclaims all warranties in case of improper use or disassembly and software modifications not described in this document or when using improper or faulty tools. Commissioning and operation of the device by qualified personnel only. All applicable regulations have to be observed.

SysMik® and the SysMik logo are registered trademarks of SysMik GmbH Dresden. IPOCS™ is trademark of SysMik GmbH Dresden. "Networking Together!"® is subject to copyright of SysMik GmbH Dresden.

All other trademarks mentioned in this document are registered properties of their owners. These and further trademarks are used in this document but not marked for better readability.

No part of this document may be reproduced or modified in any form without prior written agreement with SysMik GmbH Dresden.

Copyright © 2014 by SysMik GmbH Dresden

SysMik GmbH Dresden	Tel	+ 49 (0) 351 – 4 33 58 – 0
Bertolt-Brecht-Allee 24	Fax	+ 49 (0) 351 – 4 33 58 – 29
01309 Dresden	E-Mail (Sales)	sales@sysmik.de
	E-Mail (Support)	service@sysmik.de
Germany	Homepage	www.sysmik.de

Contents

Device Description	1
Contents	3
1 Overview	4
2 Order Information	4
3 Connections	5
3.1 Wiring Example	7
3.2 Installation Instructions	7
4 Selecting Measuring Mode and Sensors	8
1.1 Systematic Errors	8
1.2 Tolerance and Drift	8
5 Technical Data	11
6 Literature	12

1 Overview

The terminal IB IL AI/TEMP 4 RTD-PAC is designed for use within an Phoenix Contact Inline station. It provides 4 analog input channels, which can be configured independently from each other either as voltage or resistance and/or resistive temperature detector (RTD) inputs.

The sensor interface uses 2-wire technology, hence a nominal sensor resistance of at least 1000 Ω is being advised in case of sensors with comparatively small temperature coefficient (e.g. platinum sensors).

For temperature measurement with NTC sensors, whose big advantage is a large temperature coefficient, use resistance measurement with temperature calculation by means of characteristics interpolation performed by the bus controller.

The terminal with its 4 channels and a width of 12.2 mm is very compact built.

Features:

- 4 analoge inputs, configurable as
- 0-10 V voltage inputs
- resistor inputs from 10 Ω up to 300 k Ω , values either as Ohm or percent
- Platinum sensors according to DIN EN 60751 and/or IEC 751 and SAMA
- Nickel sensors according to DIN 43760 and SAMA
- KTY81-110, KTY81-210, KTY84
- Viessmann Ni500, Viessmann NTC10 k
- Siemens LG-Ni1000
- Temperature output as Celsius [$^{\circ}\text{C}$] or Fahrenheit [$^{\circ}\text{F}$]
- width only 12.2 mm (0.48 inch)
- 2-wire technology

Note: This data sheet is only valid in association with the IL SYS INST UM E user manual of Phoenix Contact (see [1]) or the Inline system manual for your bus system.

2 Order Information

Device	Part number
IL AI/TEMP 4 RTD	1225-100275-07-6

Table 2.1: Order information

3 Connections

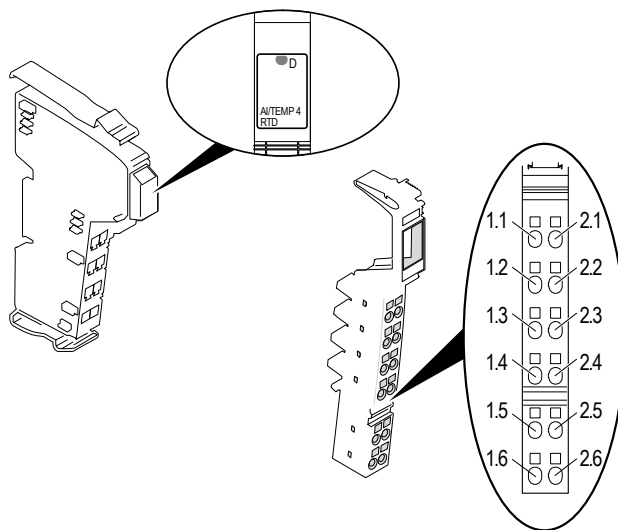

Fig. 3.1: Terminal connections

Indicator	Color	Description
D	green	bus diagnostics

Table 3.1: Local diagnostic and status indicator

Terminal point	Signal	Assignment
1.1	+AI ₁	sensor (both resistance and voltage) input channel 1
1.2	AGND ¹⁾	sensor ground channel 1
1.3	Shield ¹⁾	shield channel 1
1.4	+AI ₃	sensor (both resistance and voltage) input channel 3
1.5	AGND ¹⁾	sensor ground channel 3
1.6	Shield ¹⁾	shield channel 3
2.1	+AI ₂	sensor (both resistance and voltage) input channel 2
2.2	AGND ¹⁾	sensor ground channel 2
2.3	Shield ¹⁾	shield channel 2
2.4	+AI ₄	sensor (both resistance and voltage) input channel 4
2.5	AGND ¹⁾	sensor ground channel 4
2.6	Shield ¹⁾	shield channel 4

¹⁾ Connectors AGND and Shield are internally connected to each other

Table 3.2: Terminal assignment

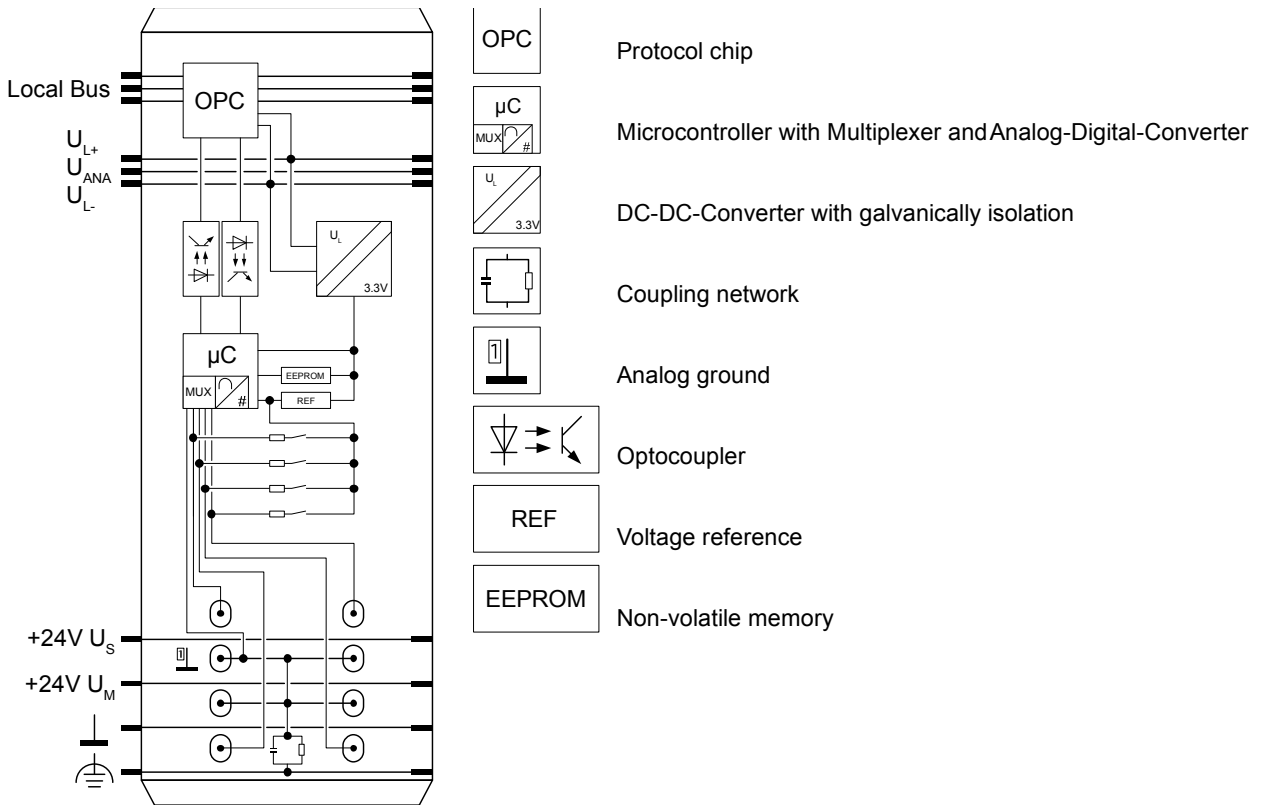

Fig. 3.2: Functional overview (without plug)

3.1 Wiring Example

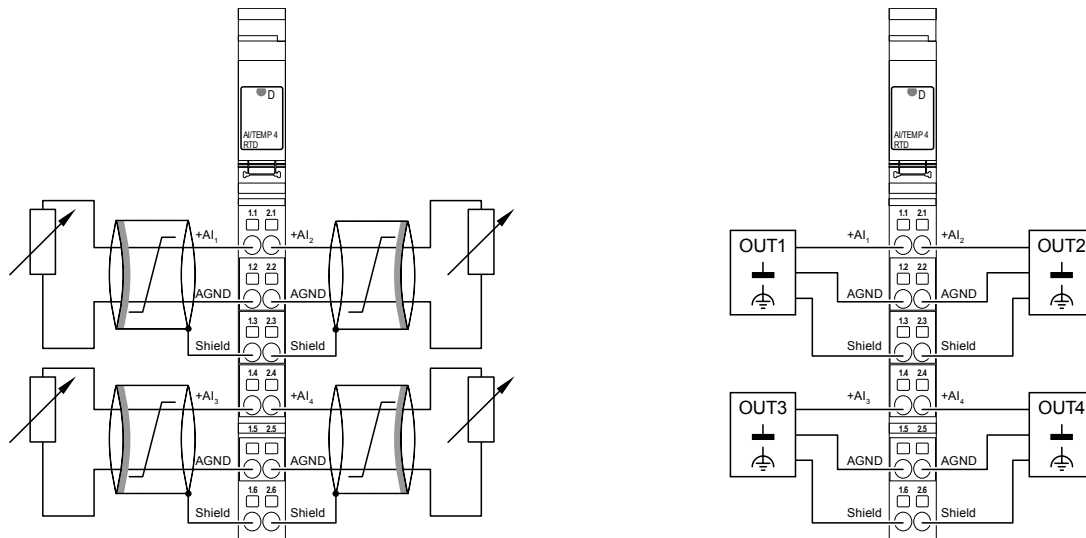

Fig 3.1.1: Wiring example of resistive sensors (left) and voltage measurement (right)

Note: Always connect sensors using twisted pair cabling.

Note: Shielding may reduce the influence of electromagnetic interferences. Connect the shield with the shield connector of the terminal and isolate it at the sensor.

Note: Short-circuit unused channels to sensor ground.

3.2 Installation Instructions

Currents flowing through the potential jumpers U_M and U_S cause a temperature rise inside the terminal. Note the following instruction to minimize this influence:

Instruction: Create a separate main circuit for the analog terminals or place the analog circuits after all other terminals at the end of a main circuit!

4 Selecting Measuring Mode and Sensors

1.1 Systematic Errors

When measuring resistance and temperature by means of resistive temperature sensors, systematic errors may cause significant errors.

With 2-wire technology, the biggest systematic error is caused by the resistance of the sensor cable and the contact resistances.

The measuring error is proportional to the relation between resistance of sensor cables and contacts and coefficient of the sensor. This error cannot completely be compensated by calibration, because it is depending from the temperature of the cable.

The temperature coefficient of Pt100 sensors is approximately $0.385 \Omega/K$. The resistance of a 10 m sensor cable with a cross section of 0.5 mm^2 is about 0.712Ω and distorts the measuring result by nearly 2 K. The temperature depending change of the cable resistance and the contact resistance have to be additionally considered.

The temperature coefficient of Pt1000 is 10 times higher in comparison to Pt100. According to that, the influence of cable and contact resistance is 10 times smaller. There are resistive temperature sensors with even higher temperature coefficients, e.g. NTC sensors.

Note: Chose temperature sensors with temperature coefficients as high as possible in order to minimize the influence of systematic errors. We recommend sensors of appropriate type (preferable NTC) and/or with a nominal resistance of at least 1000Ω (with Ni or Pt).

1.2 Tolerance and Drift

The influence of measuring errors, which are caused by tolerance and drift of the measuring device, can be reduced by proper choice of measuring mode and sensor type. Basically, the same recommendations as with systematic errors have to be considered.

Table 5.2.1 shows an overview of tolerance and drift of the several measuring modes. Table 5.2.2 contains an overview of the temperature coefficients of selected sensor types. With this information, it can be estimated, which errors can be caused by a certain combination of measuring mode and sensor type.

Note: Regard 3.2 in order to reduce temperature rise of the terminal within the Inline station and the resulting temperature drift of the terminal.

Measuring mode	Range ¹⁾	Tolerance			
		Typical		Maximal	
		Absolute	Relative ²⁾	Absolute	Relative ²⁾
T_U = 25 °C (77 °F)					
0-10 V	0-10 V	±20 mV	±0.2 %	±50 mV	±0.5 %
0-3 kΩ	0-2.2 kΩ ³⁾	±1 Ω	±0.1 %	±3.0 Ω	±0.2 %
0-500 kΩ	0-5 kΩ	±5 Ω	±0.1 %	±10 Ω	±0.2 %
	5-20 kΩ	±20 Ω	±0.1 %	±40 Ω	±0.2 %
	20-100 kΩ	±300 Ω	±0.3 %	±600 Ω	±0.6 %
	20-300 kΩ	±2500 Ω	±0.8 %	±5000 Ω	±1.7 %
T_U range of -25 °C to +55 °C (-13 °F to 131 °F)					
0-10 V	0-10 V	±50 mV	±0.5 %	±150 mV	±1.5 %
0-3 kΩ	0-2.2 kΩ ³⁾	±2 Ω	±0.1 %	±8 Ω	±0.4 %
0-300 kΩ	0-5 kΩ	±10 Ω	±0.2 %	±20 Ω	±0.4 %
	5-20 kΩ	±80 Ω	±0.4 %	±160 Ω	±0.8 %
	20-100 kΩ	±1500 Ω	±1.5 %	±3000 Ω	±3.0 %
	100-300 kΩ	±12000 Ω	±4.0 %	±24000 Ω	±8.0 %

¹⁾ A measuring mode can comprise multiple virtual ranges, each of which has to be considered separately, because the accuracy of measuring mode varies over its full range.

²⁾ Relative specifications are related to the upper limit of the respective range.

³⁾ Tolerance specifications only valid up to 2.2 kΩ

Table 4.1: Tolerance of measuring modes

Sensor type	Temperature range		Resistance range		Temperature coefficient at 25 °C (77 °F)
	from	to	from	to	
NTC10 k, B=3988	0 °C	70 °C	32650.0 Ω	1752.0 Ω	-461.00
NTC20 k, B=4300	0 °C	70 °C	71126.0 Ω	3061.0 Ω	-996.00
Pt1000 DIN	-100 °C	850 °C	603.4 Ω	3904.8 Ω	3.88
Pt1000 SAMA	-200 °C	600 °C	166.6 Ω	3118.7 Ω	3.88
Ni1000 DIN	-60 °C	180 °C	695.2 Ω	2232.2 Ω	5.81
Ni1000 SAMA Type I	-40 °C	200 °C	779.0 Ω	2490.2 Ω	6.11
KTY81-110	-55 °C	150 °C	490.0 Ω	2211.0 Ω	7.80
KTY81-210	-55 °C	150 °C	980.0 Ω	4280.0 Ω	15.60
KTY84	-40 °C	300 °C	359.0 Ω	2624.0 Ω	4.40
Siemens LG Ni 1000	-30 °C	160 °C	871.7 Ω	1863.6 Ω	4.70
Viessmann Ni 500	-40 °C	40 °C	412.0 Ω	576.0 Ω	2.40
Viessmann NTC 10 k	10 °C	110 °C	20000.0 Ω	400.0 Ω	-625.00

Table 4.2: Selected sensor parameters

5 Technical Data

General data		
Dimensions (width x height x depth)	without connectors	12.2 mm x 120 mm x 71.5 mm
	with connectors	12.2 mm x 142 mm x 71.5 mm
Weight	without connectors	46 g
	with connectors	68 g
Operating mode		process data operation with 2 words
Permissible temperature	operation	-25 °C to +55 °C (-13 °F to +131 °F)
	storage / transport	-25 °C to +85 °C (-13 °F to +185 °F)
Permissible humidity		75 % on average, 85 % occasionally (non condensing)
Permissible air pressure	operation	80 kPa to 106 kPa (up to 2000 m / 6562 ft. above sea level)
	storage / transport	70 kPa to 106 kPa (up to 3000 m / 9843 ft. above sea level)
Degree of protection		IP20 according to IEC 60529

Interfaces	
Local bus	
Connection	through data routing
Transmission speed	500 kBaud

Power consumption	
Communications power UL	7.5 V DC
Current consumption at UL	≤ 60 mA (typical)
Total power consumption	≤ 0.45 W (typical)

Analog inputs	
Number	4
Signal connection	2-wire, shielded
Sensor types	Pt, Ni, KTY, voltage 0-10 V
Characteristic curves	according to DIN, according to SAMA
Conversion time of the A/D converter	150 ms
Process data update of all 4 channels	600 ms

Electrical isolation	
Electrical potentials	
<p>The device is solely supplied by the logic circuit (logic voltage $U_L = 7.5 \text{ V}$). The analog inputs relate to a common electrical potential, which is galvanically isolated from all other circuits (U_L, main circuit U_M, segment circuit U_S, analog circuit U_{ANA}).</p> <p>Functional earth FE is a separate electrical potential and is connected to shield and analog ground via a coupling network, composed of an 1 MΩ resistor and a 1 nF capacitor in parallel.</p>	
Isolated voltages	
Analog inputs $\leftrightarrow U_L / U_M / U_S / U_{ANA}$	500 V AC, 50 Hz, 1 min

Table 5.1: Technical data

6 Literature

- [1] User manual IL SYS INST UM E: "Automation Terminals of the Inline Product Range", Phoenix Contact
Phoenix Contact order no. 2698737
- [2] www.phoenixcontact.com
- [3] www.sysmik.de