

# User Manual

Version V1.1

March 2010

## ***INEOS 600***

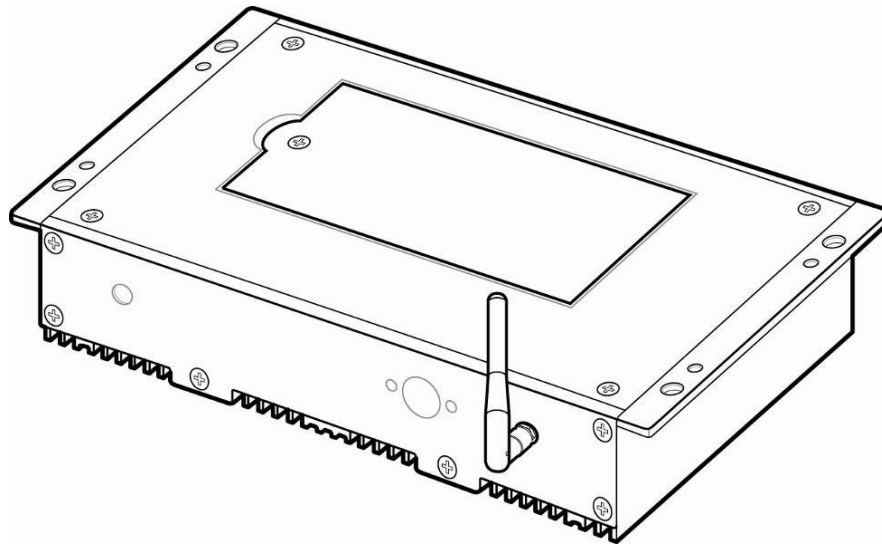

Copyright 2009~2010  
All Rights Reserved  
Manual Version 1.1

The information contained in this document is subject to change without notice.

We make no warranty of any kind with regard to this material, including, but not limited to, the implied warranties of merchantability and fitness for a particular purpose. We shall not be liable for errors contained herein or for incidental or consequential damages in connection with the furnishing, performance, or use of this material.

This document contains proprietary information that is protected by copyright. All rights are reserved. No part of this document may be photocopied, reproduced or translated to another language without the prior written consent of the manufacturer.

## **TRADEMARK**

Intel®, Pentium® and MMX are registered trademarks of Intel® Corporation. Microsoft® and Windows® are registered trademarks of Microsoft Corporation.

Other trademarks mentioned herein are the property of their respective owners.

# Safety

## IMPORTANT SAFETY INSTRUCTIONS

1. To disconnect the machine from the electrical power supply, turn off the power switch and remove the power cord plug from the wall socket. The wall socket must be easily accessible and in close proximity to the machine.
2. Read these instructions carefully. Save these instructions for future reference.
3. Follow all warnings and instructions marked on the product.
4. Do not use this product near water.
5. Do not place this product on an unstable cart, stand, or table. The product may fall, causing serious damage to the product.
6. Slots and openings in the cabinet and the back or bottom are provided for ventilation to ensure reliable operation of the product and to protect it from overheating. These openings must not be blocked or covered. The openings should never be blocked by placing the product on a bed, sofa, rug, or other similar surface. This product should never be placed near or over a radiator or heat register or in a built-in installation unless proper ventilation is provided.
7. This product should be operated from the type of power indicated on the marking label. If you are not sure of the type of power available, consult your dealer or local power company.
8. Do not allow anything to rest on the power cord. Do not locate this product where persons will walk on the cord.
9. Never push objects of any kind into this product through cabinet slots as they may touch dangerous voltage points or short out parts that could result in a fire or electric shock. Never spill liquid of any kind on the product.

## CE MARK



This device complies with the requirements of the EEC directive 2004/108/EC with regard to “Electromagnetic compatibility” and 2006/95/EC “Low Voltage Directive”.

## FCC

This device complies with part 15 of the FCC rules. Operation is subject to the following two conditions:

- (1) This device may not cause harmful interference.
- (2) This device must accept any interference received, including interference that may cause undesired operation.

# CAUTION ON LITHIUM BATTERIES

There is a danger of explosion if the battery is replaced incorrectly. Replace only with the same or equivalent type recommended by the manufacturer. Discard used batteries according to the manufacturer's instructions.

## LEGISLATION AND WEEE SYMBOL

2002/96/EC Waste Electrical and Electronic Equipment Directive on the treatment, collection, recycling and disposal of electric and electronic devices and their components.

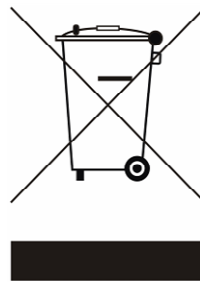

The crossed dustbin symbol on the device means that it should not be disposed of with other household wastes at the end of its working life. Instead, the device should be taken to the waste collection centers for activation of the treatment, collection, recycling and disposal procedure.

To prevent possible harm to the environment or human health from uncontrolled waste disposal, please separate this from other types of wastes and recycle it responsibly to promote the sustainable reuse of material resources.

Household users should contact either the retailer where they purchased this product, or their local government office, for details of where and how they can take this item for environmentally safe recycling.

Business users should contact their supplier and check the terms and conditions of the purchase contract.

This product should not be mixed with other commercial wastes for disposal.

# Revision History

Changes to the original user manual are listed below:

<b>Version</b>	<b>Date</b>	<b>Description</b>
1.0	Oct. 2009	<ul style="list-style-type: none"><li>• Initial release</li></ul>
1.1	Mar. 2010	Chapter 4.2 <ul style="list-style-type: none"><li>• Delete Boot Display Device Setting</li><li>• Update LCD ID setting</li></ul>

# Table of Contents

<b>1 Package Checklist .....</b>	<b>1</b>
1-1 Standard items.....	1
1-2 Optional items.....	2
<b>2 System View .....</b>	<b>3</b>
<b>3 System Assembly &amp; Disassembly .....</b>	<b>5</b>
3-1 Replace the HDD.....	5
3-2 Open the Box PC.....	6
3-3 Install a WLAN.....	7
3-4 Install a pSSD Card .....	9
3-5 Install a Cash Drawer .....	10
3-6 Replace the Motherboard .....	12
3-7 Install an Audio Cable .....	13
<b>4 Specification.....</b>	<b>15</b>
<b>5 Jumper Settings.....</b>	<b>17</b>
5-1 C36A V1.1 Motherboard Layout .....	17
5-2 Connectors Description .....	18
5-3 Jumper Settings.....	19
<b>6 BIOS Settings .....</b>	<b>22</b>
<b>Appendix.....</b>	<b>24</b>

# 1 Package Checklist

## 1-1 Standard items

a.

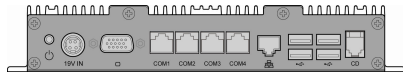

b.

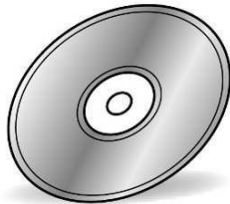

c.



d.

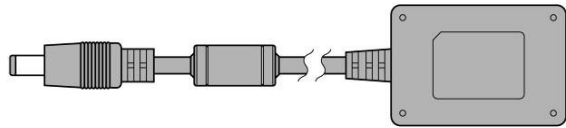

e.



f.



- a. Fanless Box PC
- b. Driver bank
- c. User Manual
- d. power adapter
- e. power cord
- f. RJ45 to DB9 cable (x2)

# 1-2 Optional items

a.

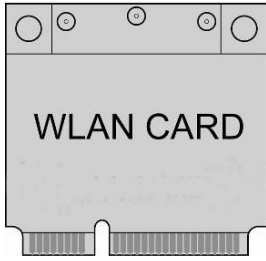

c.

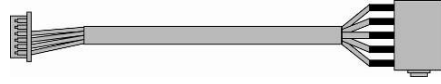

b.

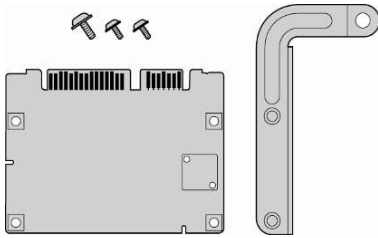

- a. WLAN Card (with external antenna)
- b. pSSD Card
- c. Audio Cable



# 2 System View

Top View

Bottom View

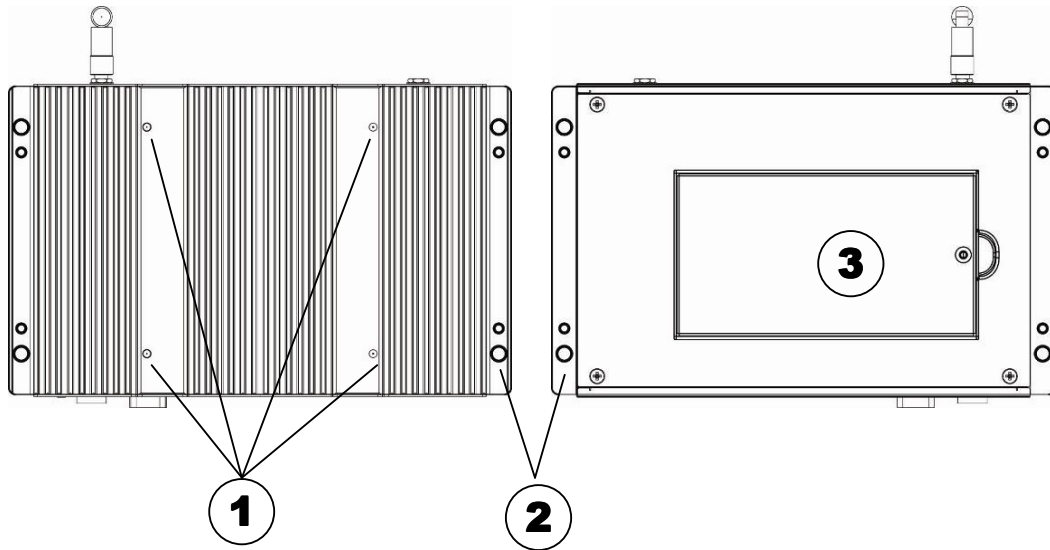

No.	Description
1	Standard VESA Holes 100x100mm
2	Wall Mounting Holes
3	HDD Door

## Front I/O View

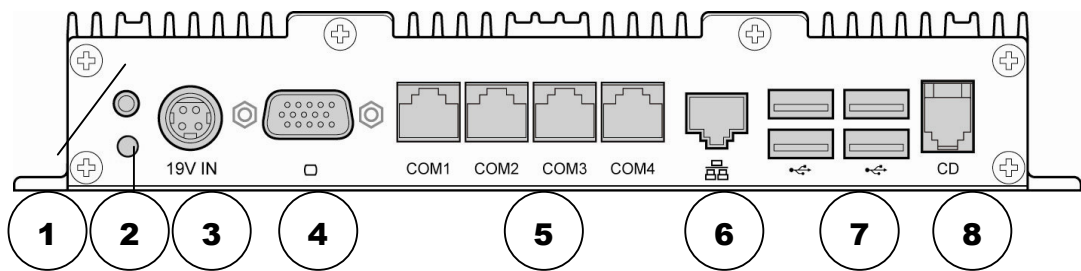

## Rear I/O View

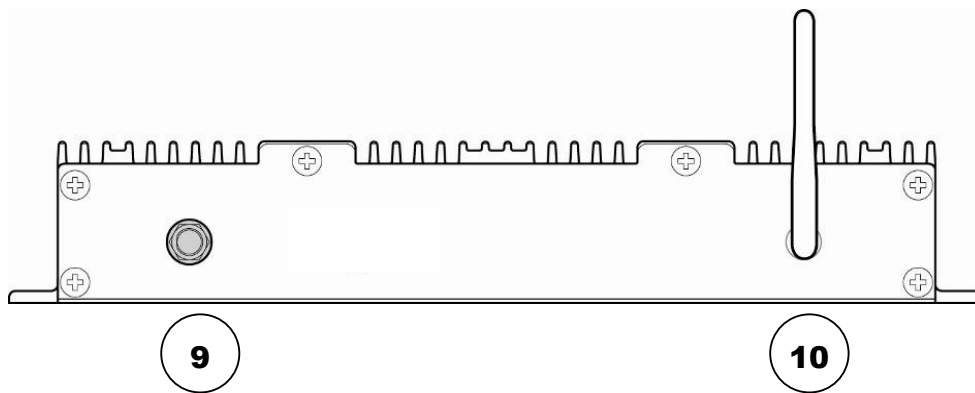

No.	Description
1	Power Button
2	Power LED Indicator
3	DC Jack
4	2nd VGA
5	Serial/COM (x4)
6	LAN (10 / 100/1000)
7	USB (x4)
8	Cash Drawer Port
9	Audio-out (Option)
10	Antenna (Option)

# 3 System Assembly & Disassembly

## 3-1 Replace the HDD



1. Remove the HDD door screw (x1) to remove the HDD cover.



2. Disconnect the HDD cable (x1) and take out the HDD.

## 3-2 Open the Box PC

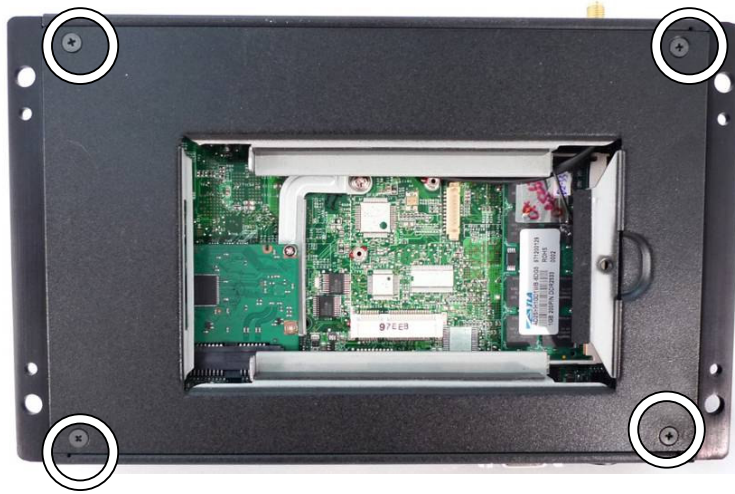

1. Remove the HDD first (see chapter 3-1).
2. Remove the screws (x4) to separate the metal rear cover from the box PC.

## 3-3 Install a WLAN

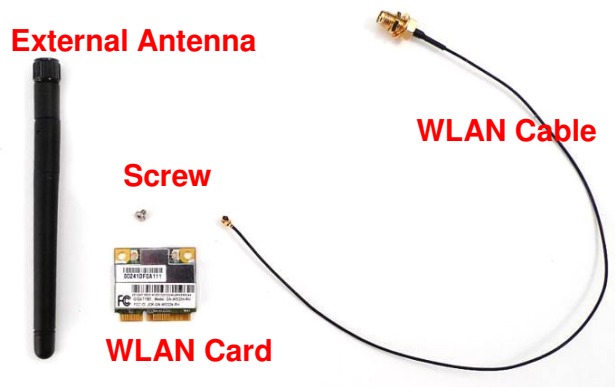

### WLAN Card Module Accessory:

- (1). External Antenna x 1
- (2). WLAN Card x 1
- (3). Screw x 1
- (4). WLAN Cable x 1



1. Remove the HDD (see Chapter 3-1).
2. Open the box PC (see Chapter 3-2).
3. Connect the WLAN Cable to the “Main Connector” of the WLAN Card.

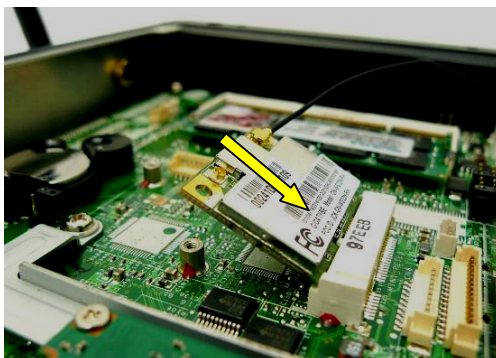

4. Slide the WLAN Card into the WLAN card slot.

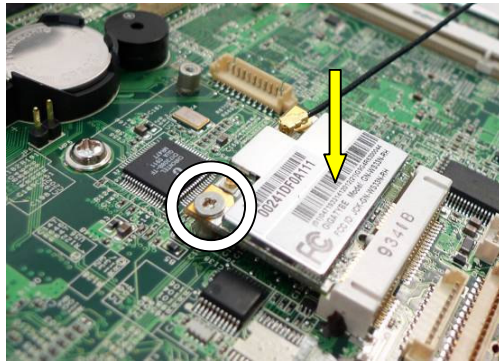

5. Press down the WLAN and fasten the screw (x1) to fix the WLAN Card to the motherboard.



6. Open the blind hole on the box PC.
7. Align and thread the other end of antenna cable through the blind hole.



8. Assemble the antenna cable and rotate the washer to fix the antenna cable to the box PC.



9. Screw the external antenna.

# 3-4 Install a pSSD Card



### pSSD Card Module Accessory:

- (1). pSSD card x 1
- (2). Screws x 2
- (3). Metal bracket x 1

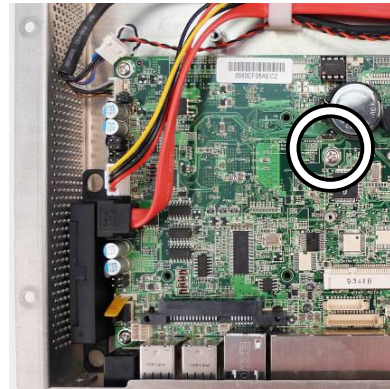
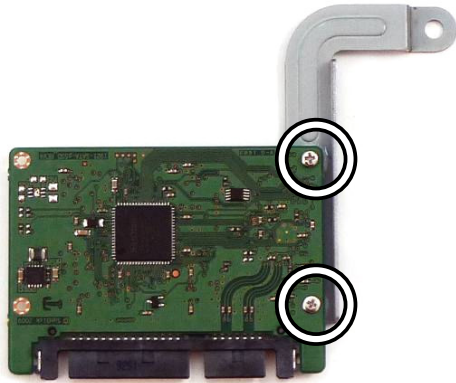

- 1. Open the box PC first (Chapter 3-1).
- 2. Assemble the metal bracket and the pSSD card by fastening the screws (x2).
- 3. Remove the screw (x1) fixing on the Motherboard.

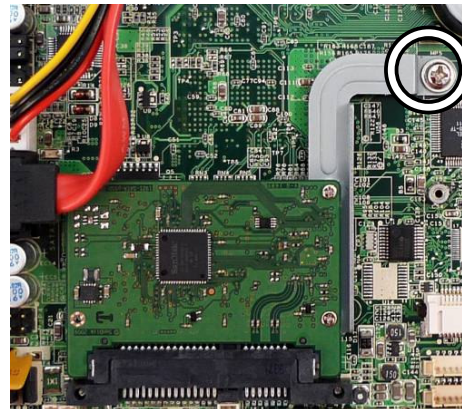
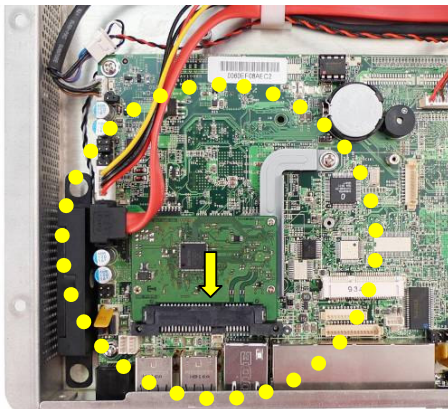

- 4. Slide the pSSD card module into the SSD/HDD slot as the position and location as above left picture shows.
- 5. Screw back the screw (x1) to fix the pSSD module to the Motherboard.

# 3-5 Install a Cash Drawer

You can install a cash drawer through the cash drawer port. Please verify the pin assignment before installation.

## Cash Drawer Pin Assignment

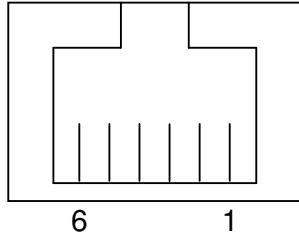

Pin	Signal
1	GND
2	DOUT bit0
3	DIN bit0
4	12V / 19V
5	DOUT bit1
6	GND

## Cash Drawer Controller Register

The Cash Drawer Controller use one I/O addresses to control the Cash Drawer.

**Register Location:** 48Ch

**Attribute:** Read / Write

**Size:** 8bit

BIT	BIT7	BIT6	BIT5	BIT4	BIT3	BIT2	BIT1	BIT0
Attribute	Reserved		Read	Reserved	Write		Reserved	

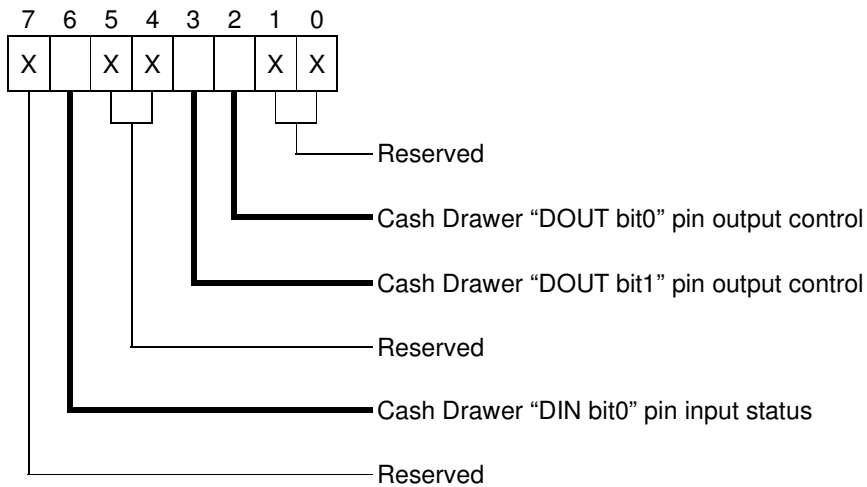



Bit 7: Reserved

Bit 6: Cash Drawer "DIN bit0" pin input status.

= 1: the Cash Drawer closed or no Cash Drawer

= 0: the Cash Drawer opened

Bit 5: Reserved

Bit 4: Reserved

Bit 3: Cash Drawer "DOUT bit1" pin output control.

= 1: Opening the Cash Drawer

= 0: Allow close the Cash Drawer

Bit 2: Cash Drawer "DOUT bit0" pin output control.

= 1: Opening the Cash Drawer

= 0: Allow close the Cash Drawer

Bit 1: Reserved

Bit 0: Reserved

Note: Please follow the Cash Drawer control signal design to control the Cash Drawer.

### Cash Drawer Control Command Example

Use Debug.EXE program under DOS or Windows98

Command	Cash Drawer
O 48C 04	Opening
O 48C 00	Allow to close
<ul style="list-style-type: none"><li>➤ Set the I/O address 48Ch bit2 =1 for opening Cash Drawer by "DOUT bit0" pin control.</li><li>➤ Set the I/O address 48Ch bit2 = 0 for allow close Cash Drawer.</li></ul>	

Command	Cash Drawer
I 48C	Check status
<ul style="list-style-type: none"><li>➤ The I/O address 48Ch bit6 =1 mean the Cash Drawer is opened or not exist.</li><li>➤ The I/O address 48Ch bit6 =0 mean the Cash Drawer is closed.</li></ul>	

## 3-6 Replace the Motherboard

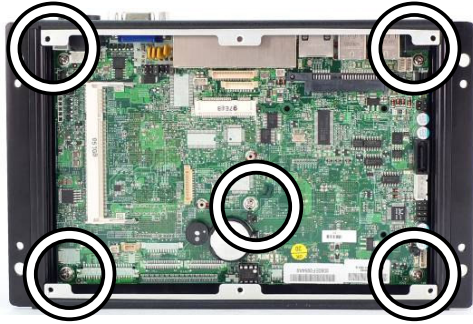

1. Disconnect the HDD cable and remove the HDD (see Chapter 3-1)
2. Open the box PC (see Chapter 3-2).
3. Disconnect all the connectors from the motherboard.
4. Unfasten the screws (x5) that fix the motherboard to the sheet metal bracket.
5. Slide out the motherboard with metal I/O bracket from the motherboard tray.

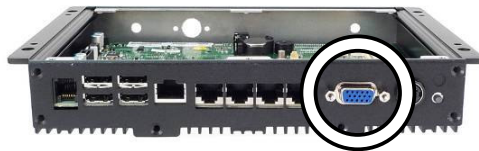

6. Unfasten the hex nuts (x2).
7. Separate the metal I/O panel from the motherboard.

## 3-7 Install an Audio Cable

To install an audio cable, you need to follow the steps:

- (1) Remove the HDD (see Chapter 3-1)
- (2) Open the control box (see Chapter 3-2)
- (3) Open the blind hole and assemble the Audio cable to the system (see below)

### Audio Cable

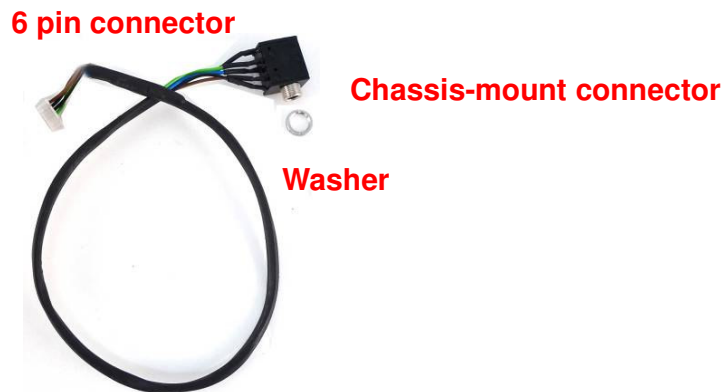

1. Open the blind hole.
2. Insert the chassis-mount connector of audio cable through the hole.



3. Fasten the washer to the connector to fix the audio cable to the system metal chassis.



4. Connect the cable to connector CN3 on the motherboard

# 4 Specification

<b>Model Name</b>	<b>Control Box</b>
<b>Motherboard</b>	<b>C36A v1.1</b>
Processor	Intel® Atom™ N270 processor 1.6GHz L2 512K FSB 533MHz
Chipset	Intel® 945GSE + ICH7M
System Memory	1 x DDR2 667MHz SO-DIMM up to 2GB
Graphic Memory	Intel® GMA 950 share system memory up to 224MB
<b>Storage Device</b>	
Hard Drive	1 x 2.5" slim SATA HDD
Flash Memory	1 x pSSD (option)
<b>Expansion</b>	
Mini PCI Slot	1
<b>Front I/O</b>	
Line-out	1 (option)
Antenna Jack	1
<b>Rear I/O</b>	
USB Port	4 x USB 2.0
Serial Port	4 x RJ-45 (COM3 / COM4 with 5V / 12V power)
LAN Port	1 x RJ-45 (10/100/1000Mbps Giga LAN)
VGA	1 x DB-15F
Cash Drawer Port	Support cash drawer 1 x (12V / 24V)
DC Jack	1 x DC-19V
Power LED Indicator	1
Power Button	1
<b>Power</b>	Adapter (DC 65W, 19V, 3.4A)
<b>Certificate</b>	
EMC & Safety	FCC Class A / CE Mark / LVD
<b>Environment</b>	
Operating Temperature	5°C ~ 35°C (41°F ~ 95°F)
Storage Temperature	-20°C ~ 55°C (-4°F ~ 140°F)
Operating Humidity	20% ~ 80% RH non-condensing
Storage Humidity	20% ~ 85% RH non-condensing

<b>Communication</b>	
Wireless LAN	mini PCI-E wireless LAN card 801.11 b/g with external antenna (option)
<b>Dimension (W x D x H)</b>	222 x 138 x 36.8 mm / 8.7" x 5.4" x 1.4"
<b>Weight</b>	1.2kg (2.6lbs)
<b>Mounting</b>	100mm x 100mm Standard VESA
<b>OS Supported</b>	Windows® XP Pro, Windows® XP Embedded, Windows® CE, Linux

# 5 Jumper Settings

## 5-1 C36A V1.1 Motherboard Layout

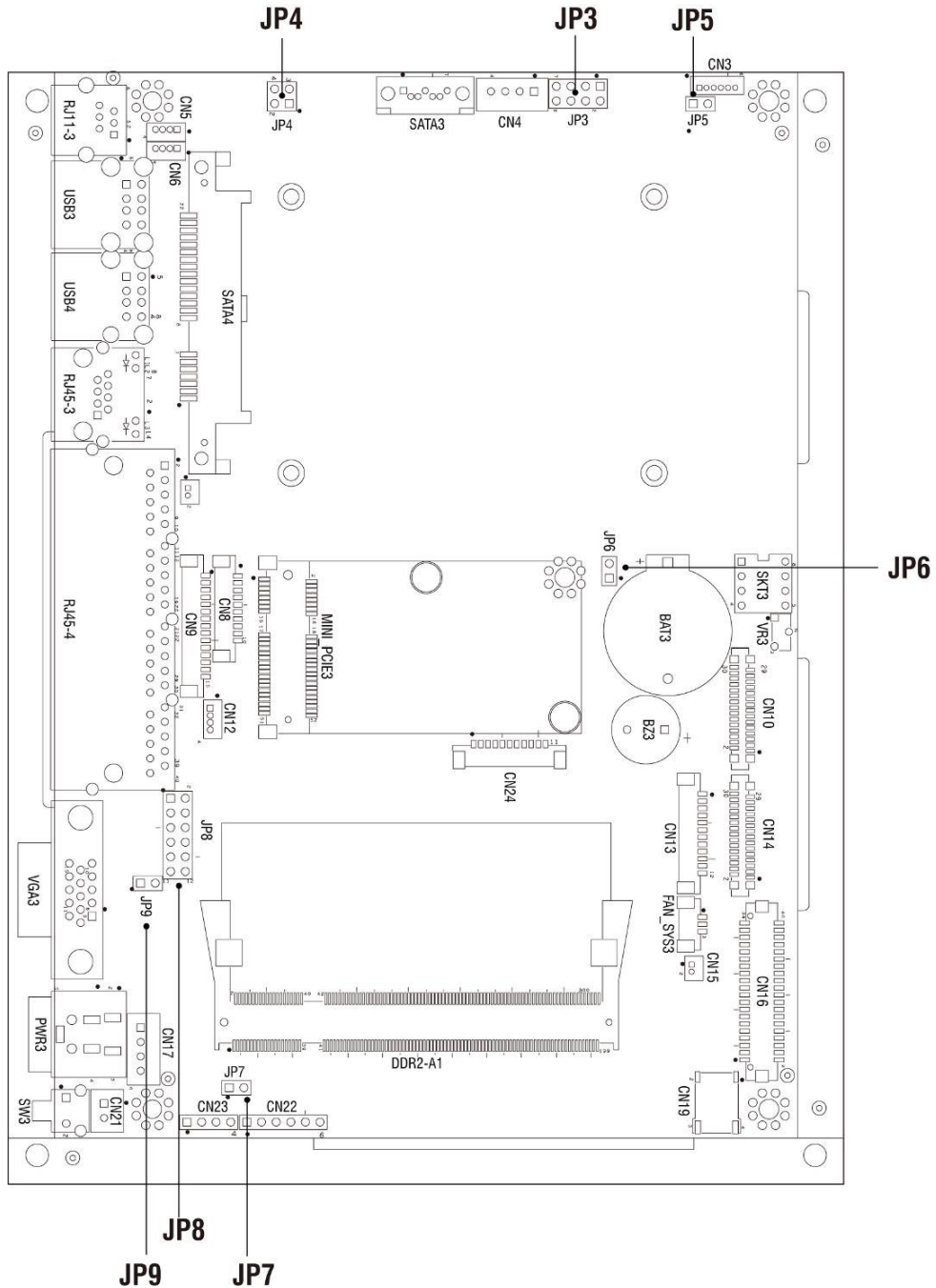

## 5-2 Connectors Description

Connector	Purpose
BAT3	CMOS Battery Base ( Use CR2023)
CN3	Speaker & MIC Connector
CN4	Power Connector For HDD
CN5	USB5
CN6	USB7
CN7	LAN LED
CN9	Card Reader Connector
CN12	IrDA Connector
CN13	Inverter Connector
CN15	Power LED
CN16	LCD Interface Connector
CN17	Internal DC-JACK connector
CN21	Internal Power On Switch Connector
CN22	5 Wire Touch
CN24	FT Status Interface
DDR2_A1	DDR2 SO-DIMM
PWR3	+19V Power Adaptor
RJ11_3	Cash Drawer Connector
RJ45_3	LAN (On Board)
RJ45_4	COM1, COM2, COM3, COM4
FAN_SYS3	System FAN Connector
MINI_PCIE3	Mini PCI-E Socket
SATA3	SATA Connector
SKT3	SPI ROM
SW3	Power On Button
USB3	USB1, USB2
USB4	USB3, USB4
VGA3	VGA Port





## 5-3 Jumper Settings



### 5-3-1 Cash Drawer Power Settings: JP4

Function	JP4 (1-2) (3-4)
+12V	1 3  2 4
⊙+19V	1 3  2 4

### 5-3-2 Power Mode Settings: JP5

Function	JP5 (1-2)
⊙ATX Power	
AT Power	

### 5-3-3 CMOS Operation Mode: JP6

Function	JP6 (1-2)
⊙CMOS Normal	
CMOS Reset	

⊙ = Factory default settings

### 5-3-4 System Reset Settings: JP7



Function	JP7 (1-2)
⊙Normal	
Reset	

### 5-3-5 COM3 & COM4 Power Settings: JP8

Function		JP8 (1-2) (3-4) (5-6) (7-8) (9-10) (11-12)																												
COM3 Pin10	RI	<table border="1"> <tr><td></td><td>1</td><td>3</td><td>5</td><td>7</td><td>9</td><td>11</td></tr> <tr><td>■</td><td>□</td><td>□</td><td>□</td><td>□</td><td>□</td><td>□</td></tr> <tr><td>■</td><td>□</td><td>□</td><td>□</td><td>□</td><td>□</td><td>□</td></tr> <tr><td></td><td>2</td><td>4</td><td>6</td><td>8</td><td>10</td><td>12</td></tr> </table>		1	3	5	7	9	11	■	□	□	□	□	□	□	■	□	□	□	□	□	□		2	4	6	8	10	12
		1	3	5	7	9	11																							
	■	□	□	□	□	□	□																							
■	□	□	□	□	□	□																								
	2	4	6	8	10	12																								
⊙+5V	<table border="1"> <tr><td></td><td>1</td><td>3</td><td>5</td><td>7</td><td>9</td><td>11</td></tr> <tr><td>□</td><td>■</td><td>□</td><td>□</td><td>□</td><td>□</td><td>□</td></tr> <tr><td>□</td><td>■</td><td>□</td><td>□</td><td>□</td><td>□</td><td>□</td></tr> <tr><td></td><td>2</td><td>4</td><td>6</td><td>8</td><td>10</td><td>12</td></tr> </table>		1	3	5	7	9	11	□	■	□	□	□	□	□	□	■	□	□	□	□	□		2	4	6	8	10	12	
	1	3	5	7	9	11																								
□	■	□	□	□	□	□																								
□	■	□	□	□	□	□																								
	2	4	6	8	10	12																								
+12V	<table border="1"> <tr><td></td><td>1</td><td>3</td><td>5</td><td>7</td><td>9</td><td>11</td></tr> <tr><td>□</td><td>□</td><td>■</td><td>□</td><td>□</td><td>□</td><td>□</td></tr> <tr><td>□</td><td>□</td><td>■</td><td>□</td><td>□</td><td>□</td><td>□</td></tr> <tr><td></td><td>2</td><td>4</td><td>6</td><td>8</td><td>10</td><td>12</td></tr> </table>		1	3	5	7	9	11	□	□	■	□	□	□	□	□	□	■	□	□	□	□		2	4	6	8	10	12	
	1	3	5	7	9	11																								
□	□	■	□	□	□	□																								
□	□	■	□	□	□	□																								
	2	4	6	8	10	12																								
COM4 Pin10	RI	<table border="1"> <tr><td></td><td>1</td><td>3</td><td>5</td><td>7</td><td>9</td><td>11</td></tr> <tr><td>□</td><td>□</td><td>□</td><td>■</td><td>□</td><td>□</td><td>□</td></tr> <tr><td>□</td><td>□</td><td>□</td><td>■</td><td>□</td><td>□</td><td>□</td></tr> <tr><td></td><td>2</td><td>4</td><td>6</td><td>8</td><td>10</td><td>12</td></tr> </table>		1	3	5	7	9	11	□	□	□	■	□	□	□	□	□	□	■	□	□	□		2	4	6	8	10	12
		1	3	5	7	9	11																							
	□	□	□	■	□	□	□																							
□	□	□	■	□	□	□																								
	2	4	6	8	10	12																								
+5V	<table border="1"> <tr><td></td><td>1</td><td>3</td><td>5</td><td>7</td><td>9</td><td>11</td></tr> <tr><td>□</td><td>□</td><td>□</td><td>□</td><td>■</td><td>□</td><td>□</td></tr> <tr><td>□</td><td>□</td><td>□</td><td>□</td><td>■</td><td>□</td><td>□</td></tr> <tr><td></td><td>2</td><td>4</td><td>6</td><td>8</td><td>10</td><td>12</td></tr> </table>		1	3	5	7	9	11	□	□	□	□	■	□	□	□	□	□	□	■	□	□		2	4	6	8	10	12	
	1	3	5	7	9	11																								
□	□	□	□	■	□	□																								
□	□	□	□	■	□	□																								
	2	4	6	8	10	12																								
⊙+12V	<table border="1"> <tr><td></td><td>1</td><td>3</td><td>5</td><td>7</td><td>9</td><td>11</td></tr> <tr><td>□</td><td>□</td><td>□</td><td>□</td><td>□</td><td>□</td><td>■</td></tr> <tr><td>□</td><td>□</td><td>□</td><td>□</td><td>□</td><td>□</td><td>■</td></tr> <tr><td></td><td>2</td><td>4</td><td>6</td><td>8</td><td>10</td><td>12</td></tr> </table>		1	3	5	7	9	11	□	□	□	□	□	□	■	□	□	□	□	□	□	■		2	4	6	8	10	12	
	1	3	5	7	9	11																								
□	□	□	□	□	□	■																								
□	□	□	□	□	□	■																								
	2	4	6	8	10	12																								

⊙ = Factory default settings

### 5-3-6 VGA Power Settings: JP9

Function	JP9 (1-2)
Ⓞ No Power	
+12V	

### 5-3-7 LCD ID Setting

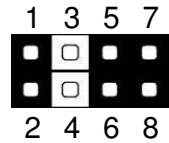
Panel Number	Resolution	LVDS		JP3 (5-6) (7-8)
		Bits	Channel	
1	1024 x 768	24	Single	

Ⓞ = Factory default settings

Note:



OPEN



SHORT

# 6 BIOS Settings

## BIOS Main Menu

When the BIOS Main Menu is displayed, the following items can be selected. Use the arrow keys to select items and the Enter key to accept and enter the sub-menu.

**Note:** The BIOS setup menus shown in this section are for reference only and may not exactly match the items of your BIOS version.

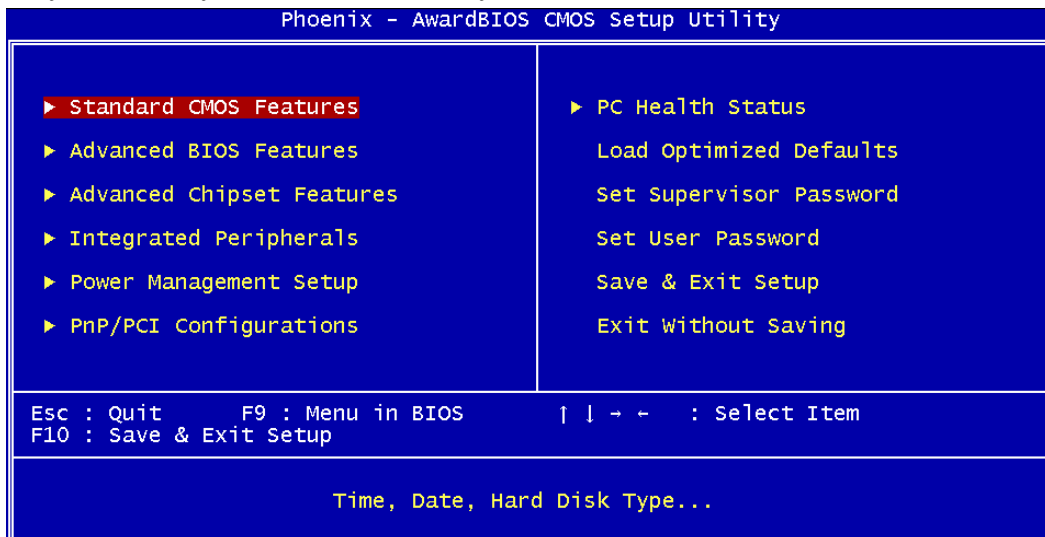

## Standard CMOS Features

Use this menu for basic system configuration.

## Advanced BIOS Features

Use this menu to set the Advanced Features available on the system.

## Advanced Chipset Features

Use this menu to change the values in the chipset registers and optimize the system's performance.

## Integrated Peripherals

Use this menu to specify your settings for integrated peripherals.

**Power Management setup**

Use this menu to specify your settings for power management.

**PnP/PCI Configurations**

This entry appears if your system supports Plug and Play and PCI Configuration.

**PC health status**

Displays CPU, System Temperature, Fan Speed, and System Voltages Value.

**Load Optimized Defaults**

Use this menu to load the BIOS default values, i.e., factory settings for optimal performance system operations. While Award has designed the custom BIOS to maximize performance, the factory has the option to change these defaults to meet their needs.

**Set Supervisor Password**

Enables you to change, set, or disable the supervisor or user password.

**Set Password**

Change, set, or disable the password. It allows you to limit access to the system and to the setup, or just to the setup.

**Save & exit setup**

Save CMOS value changes to CMOS and exits setup.

**Exit without saving**

Ignores all CMOS value changes and exits setup.

# Appendix

## **Drivers Installation:**

The shipping package includes a Driver CD. You can find every individual driver and utility that enables you to install the drivers in the Driver CD.

Please insert the Driver CD into the drive and double click on the "index.htm" to pick up the models. You can refer to the drivers installation guide for each driver in the "Driver/Manual List".