



*Commercial Series*

*Installation*

*Instructions*

*Health*

*Relaxation*

*Exhilaration*



STEAM ~ WHIRL



## MODELS: SW-10, SW-12 and SW-15 COMMERCIAL SERIES

### *GUIDELINES FOR STEAM ROOMS*

1. Walls, ceiling and floor must be completely covered with waterproof finish; tile, marble, stone or slate.
2. Any smooth surface flooring that is used such as tile or marble, should include an anti-skid finish to avoid slipping and injury.
3. Any exposed plaster, plasterboard or sheet rock surface must be well sealed with a commercial quality waterproof sealer urethane or epoxy, at least 3 coats.
4. Use cement board, **DO NOT** use green board.
5. Ceiling should be pitched away from the door 1-1/2" per foot or constructed in a gable configuration to prevent condensation from dripping.
6. Built-in seat should be slightly pitched to allow for condensation run-off.
7. Steam room must be completely enclosed with walls, door, floor and ceiling, but should not be vapor proof. A slight opening of approximately 1/4" is desired to create movement of the steam.
8. A standard glass shower door is sufficient, a special door is not necessary.
9. Make sure there is a floor drain for condensation run-off and cleaning.
10. Do not install a fan inside steam room. Hot steam rises and will escape through flapper.
11. Windows that are part of the steam room enclosure should be double paned.
12. If using lights inside steam room they must be vapor proof.
13. A deionizer or filter hooked up on incoming water line is helpful in hard/corrosive water areas.
14. Install the steam generator to hot side of water to reduce heating time, unless a water softener is hooked up. Water softeners are usually hooked up to hot side.
15. Check local utility line voltage and choose appropriate steam generator voltage; 208 Volt or 240 Volt.
16. Make sure the steam generator is installed in an upright and level position and is in a location that is **ACCESSIBLE** for Water Level Sensor Probe maintenance.
17. Steam generator should never be located where it is exposed to outside weather conditions, freezing temperatures, near flammable materials or inside the steam room.



**CONFIRM THE CORRECT MODEL HAS BEEN SELECTED**

1.	Multiply the length x width x height of the steam room enclosure <b>(A)</b>	<b>A</b>  Cubic Feet
2.	** If enclosure walls are constructed of glass, marble, concrete, stone or slate: Copy the Figure from box <b>(A)</b> to box <b>(B)</b>	<b>B</b>  Cubic Feet
3.	Total <b>(A)</b> and <b>(B)</b> for total Cubic Feet <b>(C)</b>	<b>C</b>  Cubic Feet
4.	<b>INCREASE (C) FOR EACH OF THE FOLLOWING FEATURES OF STEAM ROOM ENCLOSURE</b>	
	Add 15% for an exterior outside wall	<b>D</b>
	Add 15% for each additional foot for rooms over 8' high	<b>E</b>
	Add 15% for an extra glass panel in addition to the door	<b>F</b>
5.	Add boxes <b>(C)</b> through <b>(F)</b> for total Cubic Feet <b>(G)</b> Select recommended model from the <b>GENERATOR SIZING GUIDE</b> on Page 3	<b>G</b>  Cubic Feet

**\*\* Certain materials used in the construction of steam rooms may require a larger unit to produce the desired conditions. Consult an Architect, Designer, Contractor or the factory to determine all factors necessary to build a suitable and safe steam room. Larger Generators are available.**

- Steam-Whirl's revolutionary LED self analysis system in the Standard Series generator simplifies installation and monitors for proper electrical and water feed at all times.
- All stainless steel tanks and components.
- Extensive factory testing for all conditions.
- 6 year limited manufacturing warranty.
- Factory assistance provided from blueprint to finished product.



**GENERATOR SIZING GUIDE**

MODEL	MAXIMUM CUBIC FEET CAPACITY	KW	VOLTS	PHASE	AMPS	BREAKER SIZE	WIRE SIZE @ 100'
SW-10BD	400	10.0	240	1	42	60A	6AWG
SW-10-3BD				3	24	30A	10AWG
SW-10-8BD			208	1	48	60A	6AWG
SW-10-83BD				3	28	40A	10AWG
SW-12BD	500	12	240	1	50	70A	6AWG
SW-12-3BD				3	29	40A	10AWG
SW-12-8BD			208	1	58	80A	4AWG
SW-12-83BD				3	32	50A	8AWG
SW-15BD	650	15	240	1	63	80A	4AWG
SW-15-3BD				3	36	45A	8AWG
SW-15-8BD			208	1	72	90A	4AWG
SW-15-83BD				3	42	60A	6AWG

**BD = Blowdown (Factory Installed)**

**OPTION:** Wire two units in tandem to accommodate up to 1300 Cubic Feet capacity.

**Commercial Series** models contain (1) Steam Generator w/Pressure Gauge and Site Glass; (1) Automatic Blowdown w/24Hr Time Clock., Probe Maintenance Instructions and Installation Instructions. New Installations must also installan Accessory Kit in choice of finish. Replacement Installations Accessory Kit is optional.



## IMPORTANT SAFETY INSTRUCTIONS



When installing and using this electrical equipment, basic safety precautions should always be followed, including the following:

### 1. READ AND FOLLOW ALL INSTRUCTIONS

#### 2. WARNING

To reduce the risk of injury, do not permit children to use this product unless they are closely supervised at all times.

#### 3. WARNING

To reduce the risk of injury:

- A. The wet surfaces of steam enclosures may be slippery. Use care when entering or leaving.
- B. The steam head, steam line, plumbing and other components become extremely hot (+/- 212°F) during operation. The steam head and plumbing must be installed in a location so that contact by user cannot occur. Insulate plumbing lines for additional protection. The steam head is hot. Do not touch the steam head and avoid the steam near the steam head.
- C. After the system is shut down the components will remain hot. Do not come into contact with the steam head or components until the system has returned to a normal temperature.
- D. Prolonged exposure to steam may cause hyperthermia. Hyperthermia occurs when the internal temperature of the body reaches a level several degrees above the normal body temperature of 98.6°F. The symptoms of hyperthermia include an increase in the internal temperature of the body, dizziness, lethargy, drowsiness and fainting. The effects of hyperthermia include: Failure to perceive heat; failure to recognize the need to exit the steam room; unawareness of impending risk; fetal damage in pregnant women; physical inability to exit the steam room; and unconsciousness.
- E. Excessive temperatures have a high potential for causing fetal damage during the early months of pregnancy. Pregnant or possibly pregnant women should consult a physician regarding correct exposure.
- F. Obese persons and persons with a history of heart disease, low or high blood pressure, circulatory system problems, or diabetes should consult a physician before using a steambath.
- G. Persons using medication should consult a physician before using a steambath since some medication may induce drowsiness while other medications may affect heart rate, blood pressure and circulation.
- H. The use of alcohol, drugs, or medication can greatly increase the risk of hyperthermia.
- I. Some aroma therapy oils may cause an allergic reaction - USE WITH CAUTION.
- J. The installation of a Steam Diffuser is recommended. This device will enable the user to move comfortably around the steam shower and may help prevent burning or scalding.
- K. Always shut electricity off at the main breaker panel.

### 4. SAVE THESE INSTRUCTIONS



## PRE-INSTALLATION

1. Verify correct model has been sized for the cubic feet and type of steam room using the **GENERATOR SIZING GUIDE on Page 3**.
2. Check that the electrical power supply available is adequate for the voltage, amps and phase of the generator



### **WARNING ELECTRICAL SHOCK HAZARD**

3. All installations and service must be performed by a qualified electrician and/or plumber and conform to all local and national codes. The generator must be installed and operated according to the instructions. Failure to do so will void the warranty and could lead to injury or death due to the live electrical components involved with installation.
4. Physical size of the unit and accessibility for plumbing service and Water Level Sensor Probe maintenance must be considered.

## INSTALLATION

1. Place the steam generator, optional Thermostat Controller (TC-2) and optional 24 Hr 7 Day Timer in a location **NOT ACCESSIBLE TO CLIENTS** but that is **ACCESSIBLE TO MAINTENANCE** and not more than 40' from steam room. All steam generators are suitable for operation in ambient not exceeding 60°C/140°F. **ALL** steam generators require maintenance.
2. The steam generator should never be located where it is exposed to outside weather conditions or freezing temperatures, near flammable materials, inside the steam room or where access cannot be gained to Water Level Sensor Probe for maintenance.
3. Install in an upright and level position.
4. The serial number label should be visible and accessible for service.
5. A minimum of 2' of open unobstructed space must be left around the top and sides of the generator to allow for heat dissipation and accessibility for service.

**SEE SEPARATE INSTRUCTIONS/INSTALLATIONS FOR OPTIONAL TC-2 TEMPERATURE CONTROLLER AND 24 HR/7 DAY TIMER**

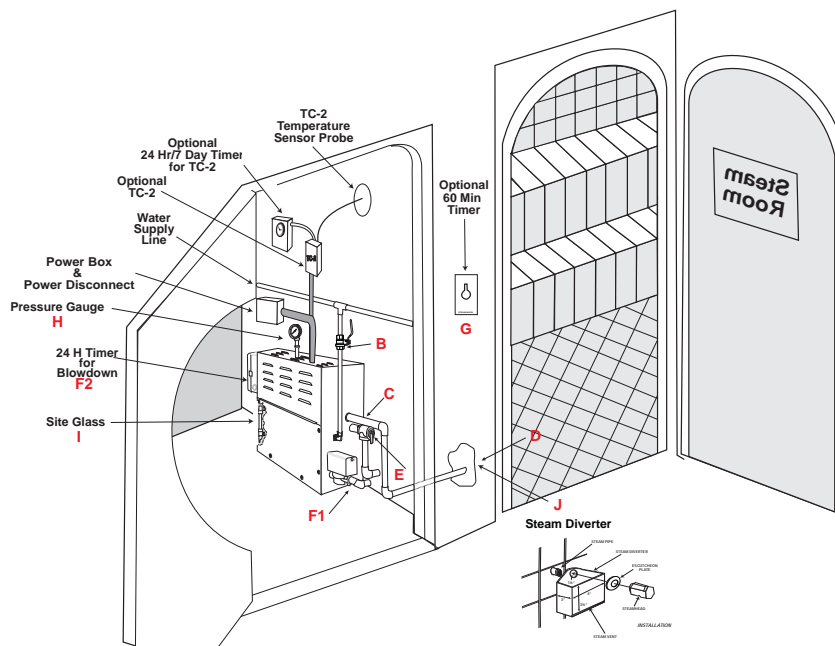

## PLUMBING

**IMPORTANT:** All plumbing should be done by a qualified plumber and must conform to all local and national plumbing codes.



### **WARNING ELECTRICAL SHOCK HAZARD**

**POWER MUST BE DISCONNECTED AT THE MAIN ELECTRICAL SUPPLY BEFORE MAKING ANY CONNECTIONS**

1. Use copper or brass fittings only. DO NOT use galvanized or black iron.  
**DO NOT USE PLUMBERS PUTTY ON ANY WATER CONNECTIONS**
2. A union must be installed close to the generator to facilitate easy removal, if necessary.
3. Tap off any existing water supply line, hot or cold, with 1/2" copper tubing or 1/2" NPT pipe. If hot water line is used temperature should not exceed 160°F. The maximum water pressure should not exceed 120psi.
4. Flush at least 1 gallon of water to clear line prior to connecting to the 1/4" compression water inlet fitting **(A in Plumbing Diagram)** on generator. When tightening this fitting, use two wrenches to avoid strain on Water Solenoid Valve inside generator.
5. Install a shut-off valve **(B in Plumbing Diagram)** on the water supply line as close to the generator as possible.  
**DO NOT USE A SADDLE VALVE**
6. For best results Install an inline filter between shut-off valve and generator.
7. For best results, steam generator should be higher than the steam head. If this is not possible, steam line must slope 1/4" per foot minimum to steam room.
8. Connect 3/4" copper tubing or 3/4" NPT pipe to steam outlet **(C in Plumbing Diagram)** and run to approximately 8-12" off finished floor in shower or just above deck of bathtub on any wall not interfering with user, seat, bench or shower entrance. For areas with acrylic or other non-heat resistant floors, install steam head 20-30" off finished floor in shower.  
**DO NOT PLACE A SHUT-OFF VALVE ON STEAM OUTLET LINE. ONLY ON WATER SUPPLY LINE.**  
**WARNING: DO NOT PLUMB VALLEYS AND DIPS WHERE WATER FROM STEAM CONDENSATION IN THE LINE COULD COLLECT AND CAUSE BLOCKAGE.**
9. Leave approximately 1/2" of threads protruding from finished wall. Place escutcheon on threads and screw on steam head **(D in Plumbing Diagram)**. Take care not to scratch the steam head with wrench. Rotate steam head until open slot is facing down.
10. **IMPORTANT:** Steam head must be installed to prevent users from coming into direct contact with the steam head and the steam coming from it. While in use the steam head and steam coming directly from it will become extremely hot (+/- 212°F).

The installation of a Steam Diffuser is recommended. This device will enable the user to move comfortably around the steam shower and may help prevent burning or scalding. **(J in Installation Diagram)**

11. Connect 3/4" copper tubing or NPT pipe to the pressure relief valve **(E in Plumbing Diagram)** and 1/2" copper tubing or NPT pipe to the Blowdown **(F in Plumbing Diagram)**. Both of these items must be installed with a union and plumbed to drain to an approved location.  
**DO NOT PLUMB THE PRESSURE RELIEF VALVE OR BLOWDOWN LINE TO THE STEAM LINE OR INTO THE STEAM ROOM. CHECK WITH LOCAL PLUMBING CODES FOR RECEPTOR, TRAP OR VENTING REQUIREMENTS.**



**PLUMBING DIAGRAM**

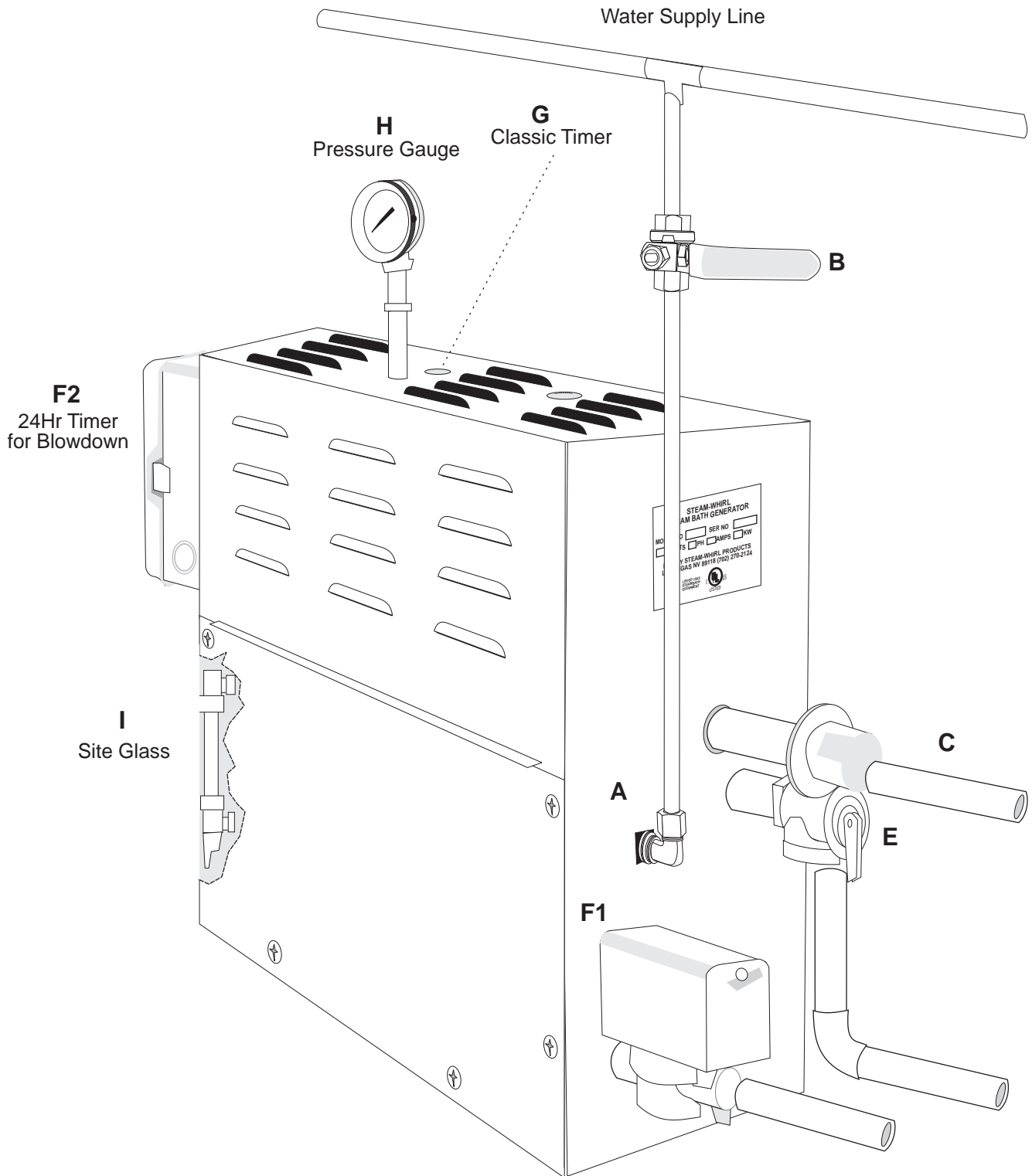





## ELECTRICAL

**IMPORTANT:** All wiring should be done by a qualified electrician and must conform to all local and national electrical codes.



### **WARNING ELECTRICAL SHOCK HAZARD**

**POWER MUST BE DISCONNECTED AT THE MAIN ELECTRICAL SUPPLY BEFORE MAKING ANY CONNECTIONS**

1. Supply wiring should be sized in accordance with the voltage and amps of the unit and suitable for 90°.
2. A separate circuit breaker must be installed and sized according to the **GENERATOR SIZING GUIDE (Page 3)**. A GFCI is not required, however if generators quick disconnect is going to be located in a damp or moist area, then a GFCI protected breaker is recommended.
3. Locate the electrical supply line knockout on top of generator enclosure. If this knockout is not going to be used, **DO NOT** drill a knockout on the left side of the enclosure (drop down door facing out). Running a electrical supply line through the left side of the enclosure could potentially damage the low voltage circuit board.
4. Strip 1/2" insulation from the two (2) power wires and the one (1) ground wire.
5. Bring the two (2) incoming electrical supply wires to L1 and L2 and the one (1) ground wire to the ground terminal.
6. If unit is a 3 Phase, bring the three (3) incoming electrical supply wire to L1, L2 and L3 and the one (1) ground wire to the ground terminal.
7. Install a power disconnect near unit.
8. Install Timer (**G in Plumbing Diagram**) according to Timer Installation Instructions.

## AUTOMATIC BLOWDOWN

1. All commercial series generators are equipped with factory installed automatic blowdown (**F1 in Plumbing Diagram**), a two position spring return valve designed to electronically drain the water from the heating tank.
2. Also installed with all commercial generators is a 24 hour time clock (**F2 in Plumbing Diagram**) wired in series with the automatic blowdown. The 24 hour timer allows the business establishment to regulate when the blowdown function is performed. It is recommended to set the timer to operate for 15 minutes when the steam room is not in high demand.
3. The automatic blowdown feature removes the water from the tank every time the generator shuts off. This keeps stagnant water from sitting in the tank between uses, giving the generator a longer life and reducing the amount of required maintenance.

**DO NOT PLUMB THE BLOWDOWN TO THE STEAM LINE OR INTO THE STEAM ROOM. CHECK WITH LOCAL PLUMBING CODES FOR RECEPTOR, TRAP OR VENTING REQUIREMENTS.**

## PRESSURE GAUGE AND SITE GLASS

1. The Pressure Gauge (**H in Plumbing Diagram**) is factory installed and requires no on site plumbing or electrical connections. The purpose of the Pressure Gauge is to detect that the unit is not building up any pressure on the steam line ie: no crimps or obstructions that would create a blow back. The Pressure Gauge should never read above 13 psi.
2. The Site Glass (**I in Plumbing Diagram**) is factory installed and requires no on site plumbing or electrical connections. The Site Glass is to ensure that the water level is above the heating element when the unit is in use, the water should fill the Site Glass more than half way.

## GENERATOR DIAGRAM

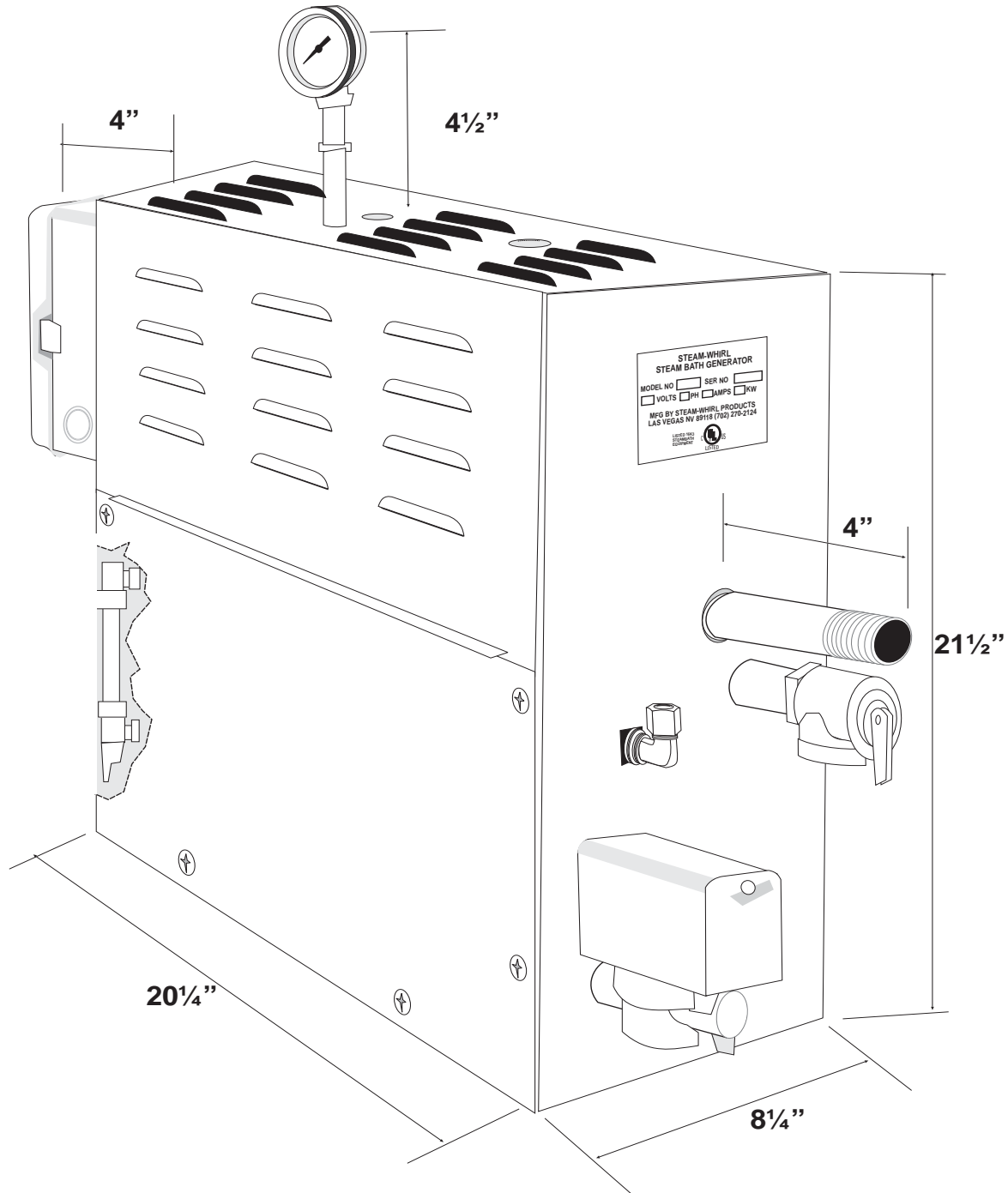

Water Supply Line	1/2" Copper Line, 1/2" NPT Female Thread
Steam Output Line	3/4" Copper Line, 3/4" NPT Female Thread
Pressure Relief Valve	3/4" Copper Line, 3/4" NPT Female Thread, Valve Supplied



# COMMERCIAL SERIES WIRING DIAGRAM - SINGLE PHASE SW-10

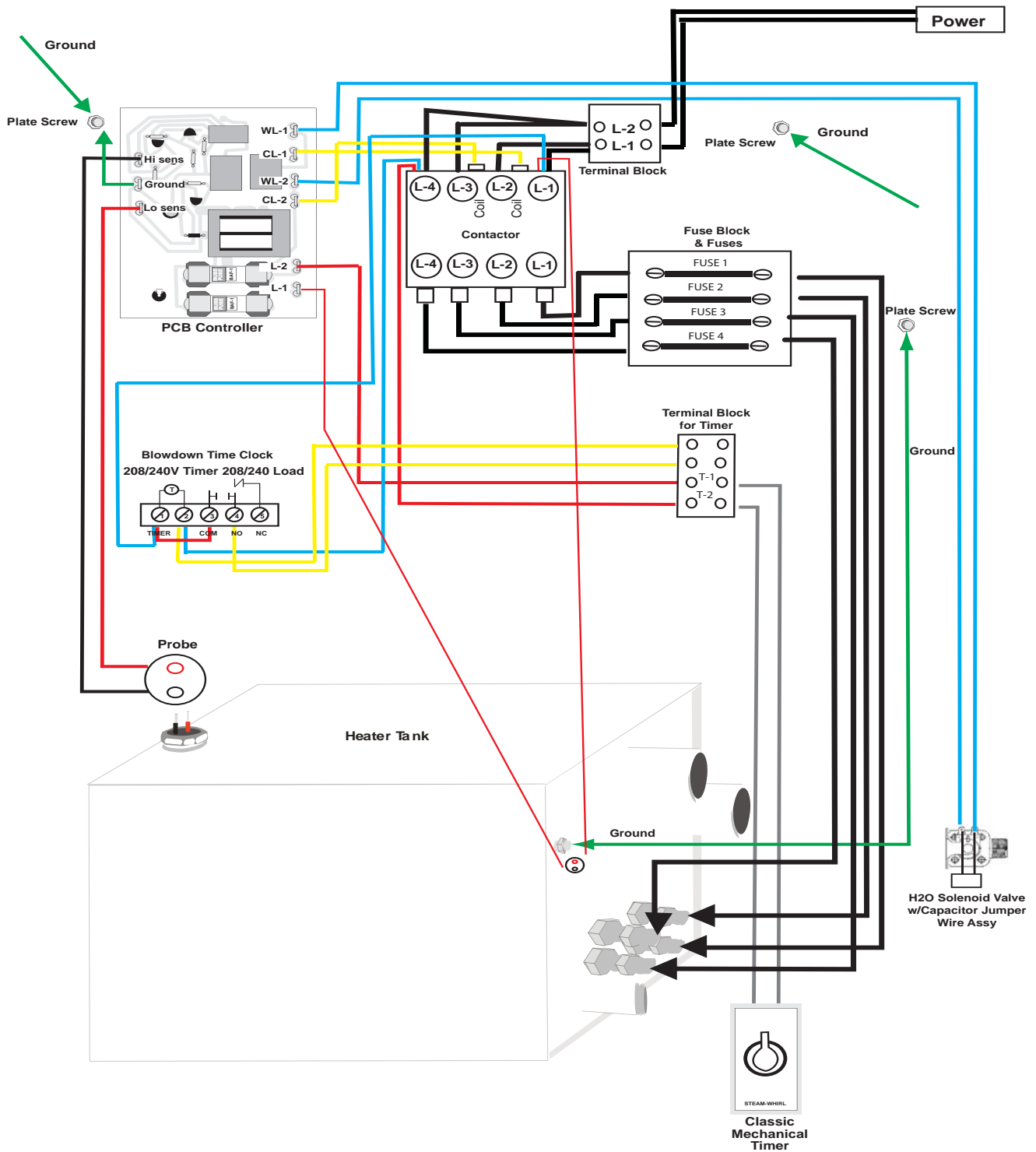

**COMMERCIAL SERIES WIRING DIAGRAM - SINGLE PHASE  
SW-12 & SW-15**

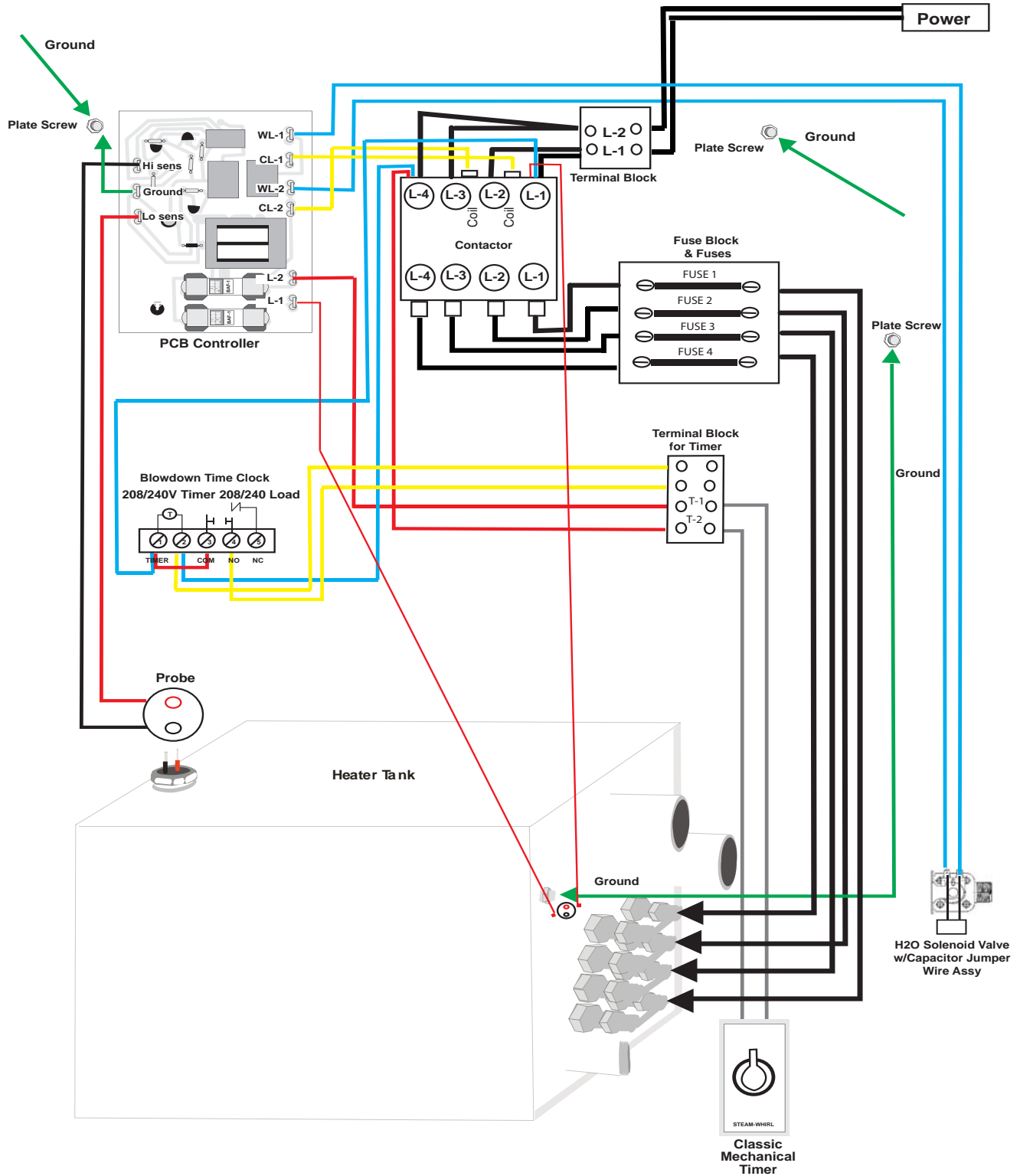



**COMMERCIAL SERIES WIRING DIAGRAM - THREE PHASE  
SW-10, SW-12 and SW-15**

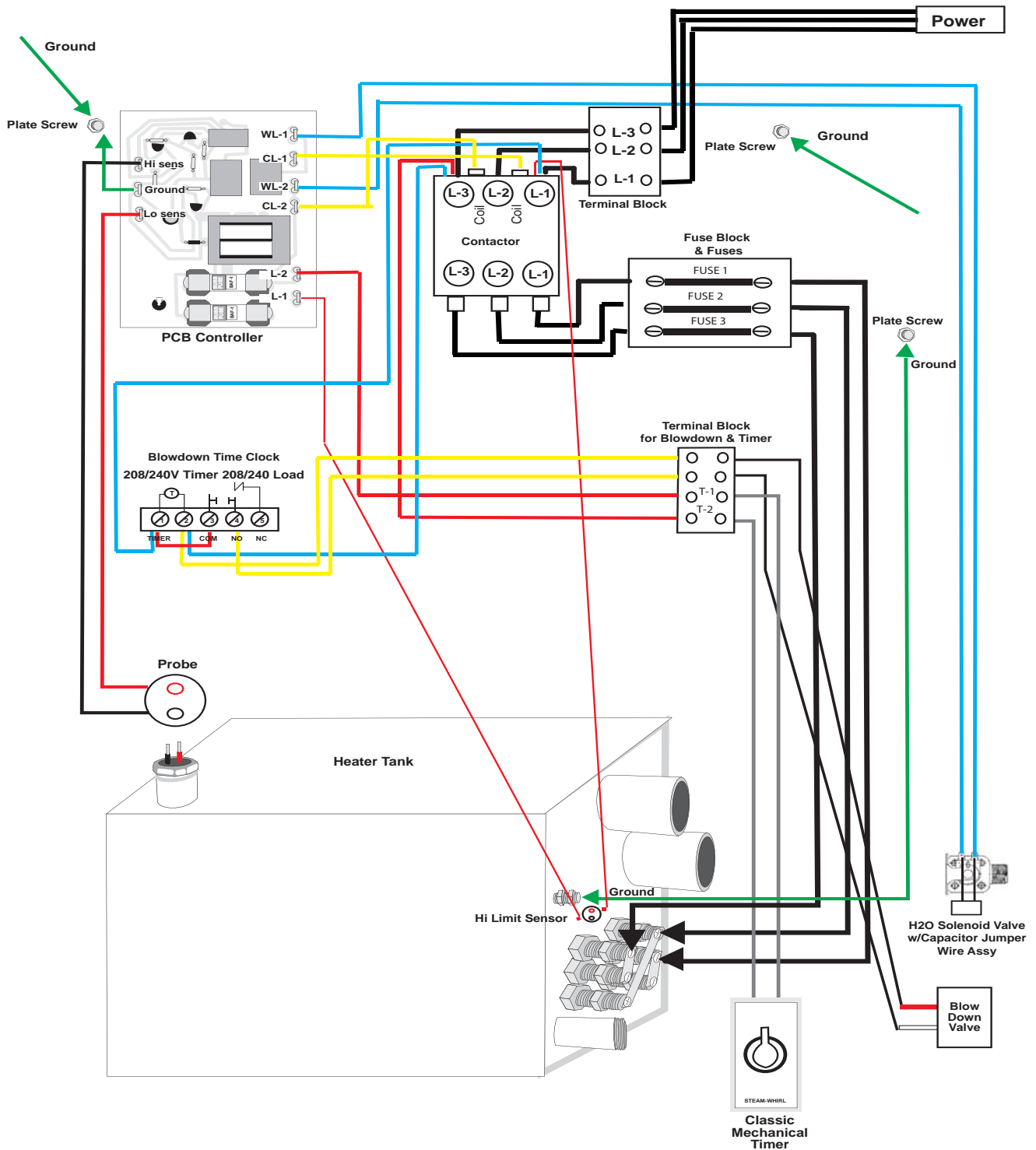



## CLASSIC SERIES TIMER INSTALLATION

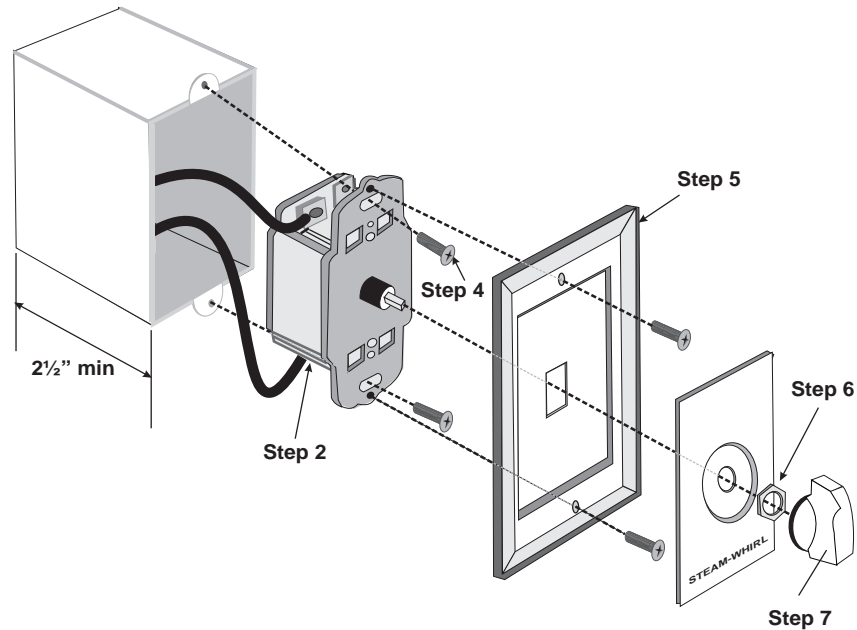

1. Turn power off at circuit breaker or fuse panel.
2. Timer should be located on a wall outside the steam room, 5' away.
- \*3. Run 14 AWG wire from back of timer 1-NO and 1-C to T1 & T2 on terminal block inside steam generator.
4. Insert wired timer into a 2-1/2" (min) deep wall box with "TOP" indicated on front cover in proper position.
5. Fasten to wall box using the two (2) screws supplied.
6. Fasten the wall plate to the timer using the two (2) screws supplied with the plate. The screws must be self-tapped into the timer body and will require gentle inward pressure while firmly turning the screw.
7. Position small plastic timer dial so that "OFF" is in the up position. Install the hex nut and tighten.
8. Push knob onto timer shaft, handle facing down.

\* **Dual Hook-Up: T1 & T2 from both units hook up to single timer.**

## SYSTEM INITIALIZATION

1. After connections are completed, make sure power and water are on.
2. Turn on timer and allow sufficient time for unit to react.
3. Timer can be turned off manually before set time has elapsed.

**TC-2 TEMPERATURE CONTROL to 60 MIN TIMER WIRING DIAGRAM**

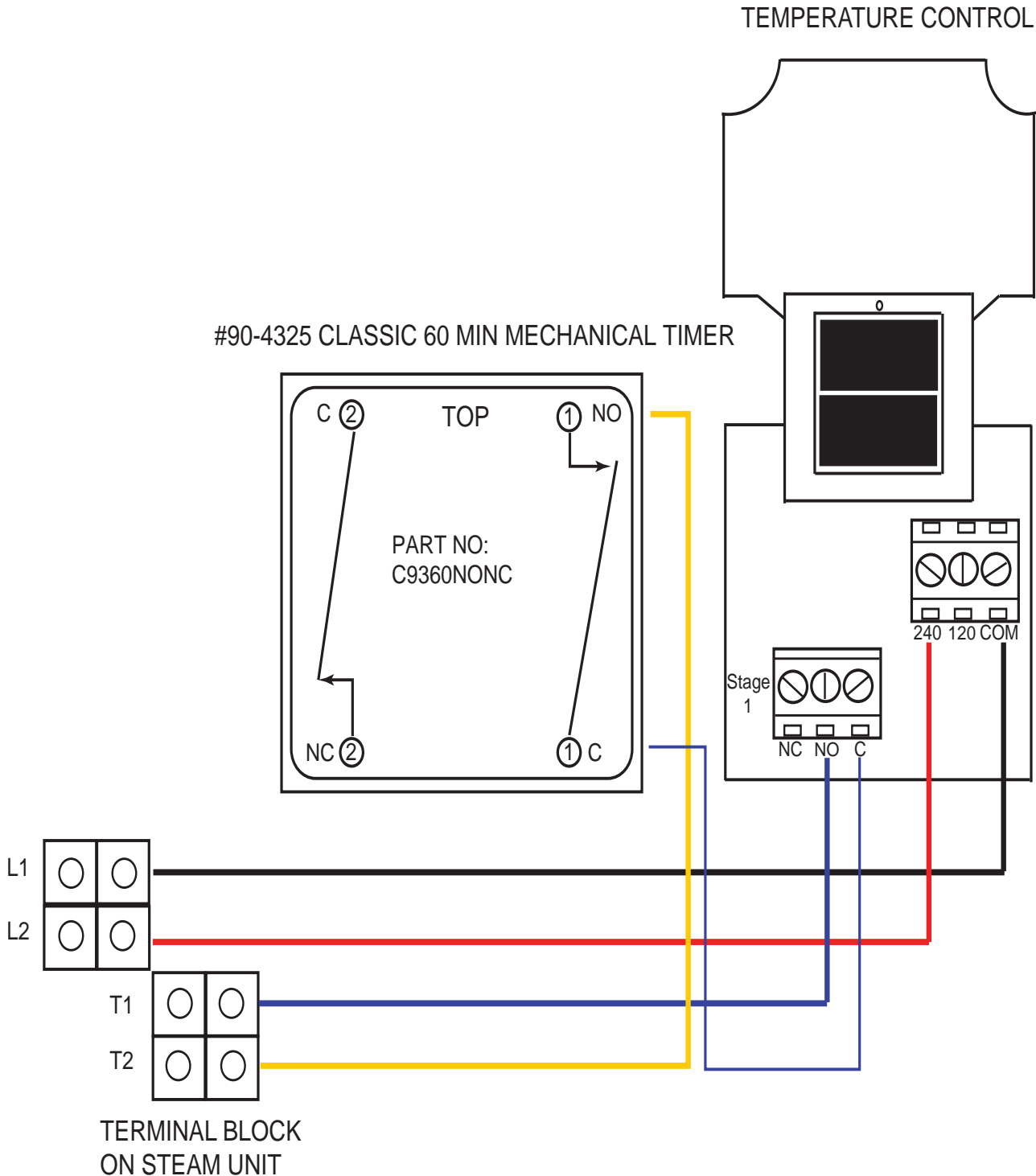

**FOLLOW SEPARATE TC-2 INSTALLATION and OPERATING INSTRUCTIONS TO PROGRAM TEMPERATURE SET POINTS.**

**TC-2 TEMPERATURE CONTROL TO TIME CLOCK WIRING DIAGRAM**

TEMPERATURE CONTROL

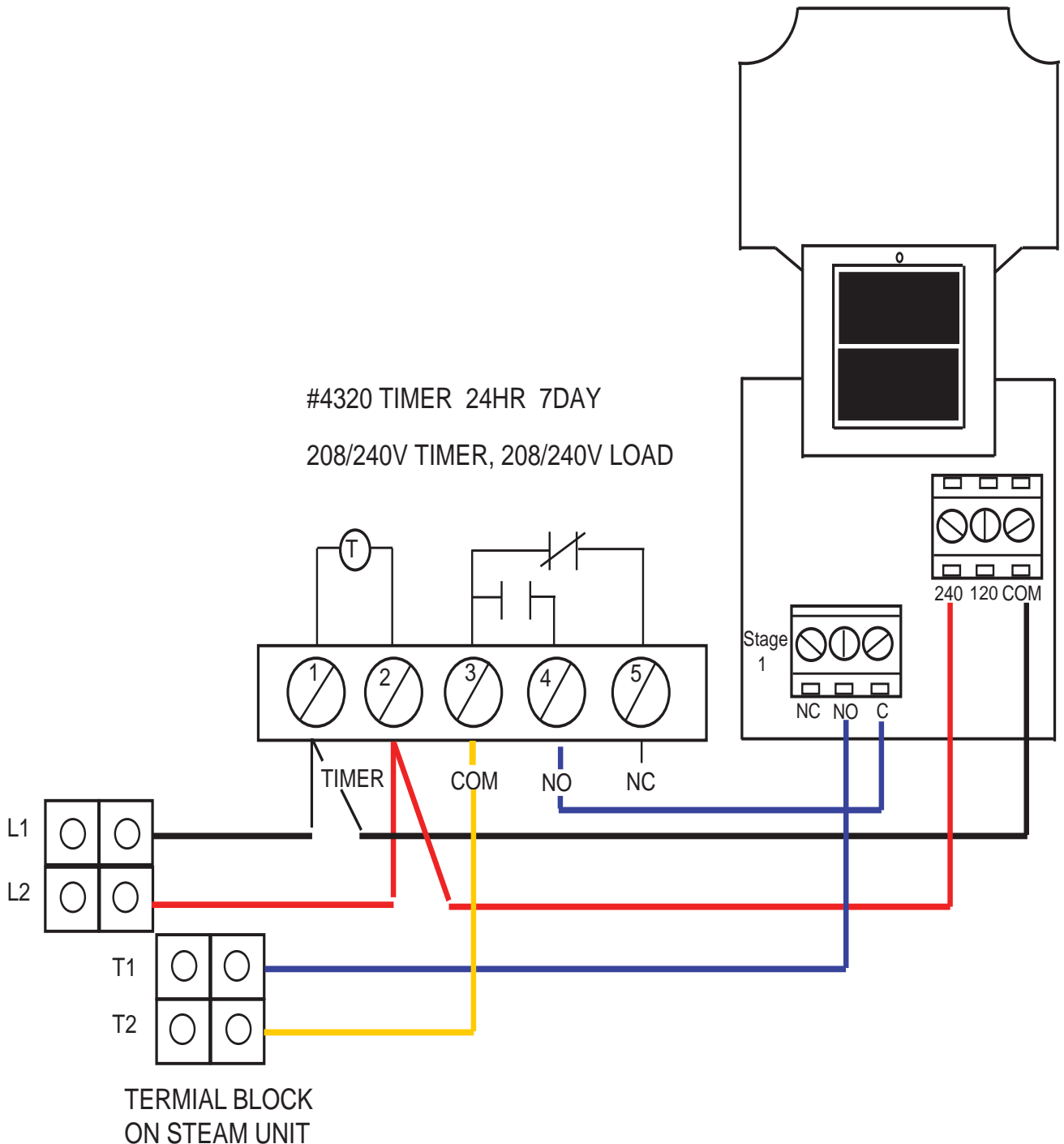

**FOLLOW SEPARATE TC-2 INSTALLATION and OPERATING INSTRUCTIONS TO PROGRAM TEMPERATURE SET POINTS AND SEPARATE #430 TIMER INSTRUCTIONS TO PROGRAM TIME SET POINTS.**





## MAINTENANCE



### **WARNING ELECTRICAL SHOCK HAZARD**

**POWER MUST BE DISCONNECTED AT THE MAIN ELECTRICAL SUPPLY BEFORE PERFORMING ANY MAINTENANCE**

1. The steam generator is designed for unattended operation and requires little maintenance.
2. Water Level Sensor Probe maintenance is as follows:
  - Shut off main electrical breaker.
  - Open drop down door in front panel of generator enclosure and with a volt meter test that there is not voltage on power side of the Terminal Block L1 and L2. (See DIAGRAMS on Pages 10, 11 and 12)
  - On left side of heater tank locate the Water Level Sensor Probe and disconnect red and black wires from the top.
  - Carefully unscrew Water Level Sensor Probe.
  - Sand off any calcium build-up or debris on sensor tips.
  - **DO NOT CUT OR TRIM SENSOR WIRES.**
  - Apply white teflon tape around thread.
  - Carefully screw Water Level Sensor Probe back in.
  - Reinstall red and black wires to top of sensor.
  - Turn on main electrical breaker.



WATER LEVEL SENSOR PROBE

### **NOTE:**

**This maintenance is suggested for any service specialist. Iron content in local water will determine the frequency of probe service. Start out at least once a month and if the probe is clean and not coated, then try every two months, etc. More frequent servicing of the probe may be needed if the unit is in an extremely hard water area or the water is supplied by a well.**

**If there is a problem with your unit please check the following before continuing on to the troubleshooting steps.**

1. Double check the correct size generator and breakers size were installed. See page 3 in your installation instructions.

**Before calling the factory or a service technician, please know the answers to the following questions.**

1. What model generator do you have and what is the serial number?  
This information can be found on the last page of the installation instructions, on your original invoice, or on the silver label on the side of the generator.
2. Do you have a classic (blue) or standard (red) unit?  
See the bottom of page 3 in your installation instructions.
3. Is your unit equipped with automatic blowdown?
4. If you have a Standard unit which timer set up do you have, Standard, Deluxe, or Combo?

**SYMPTOM**
**DIAGNOSIS**
**ACTION**

<b>Light on Timer comes on but generator does not turn on</b>	Sensor Probe Needs to be cleaned	Follow sensor probe cleaning directions. These can be found in your installation instructions.
	Sensor Probe too corroded to clean	Order new probe call 800-232-7832
	Cleaned probe but still does not work. Heater may be bad	Send unit to factory for repair or call a Service Center
<b>No Light on Timer when button pushed</b>	Heater may be bad	Send unit to factory for repair or call a Service Center
	Moisture inside of Timer	Do visual check uninstall and check for moisture damage
	Visual check OK	Send Timer to factory for testing or call a Service Center
<b>Unit Comes on by Itself</b>	Moisture inside of Timer	Do visual check uninstall and check for moisture damage
	Visual check OK	Send Timer to factory for testing or call a Service Center
<b>Unit comes on for a couple of minutes and then shuts off</b>	Bad Capacitor	Send unit to factory for repair or call Service Center
<b>Constant Water Running</b>	Check Ground	3 Green Wires
	Has Nylon Elbow been removed or tampered with?	If the Nylon Elbow has been over tightened to the water solenoid the solenoid may break. Call factory or Service Center.

**SYMPTOM**

**DIAGNOSIS**

**ACTION**

<b>Water is coming out of steam head</b>	How much?	
	More than 2 1/2 gallons per hour	Shut off unit check ground and incoming plumbing
	Less than 2 1/2 gallons per hour	Machine ok all units drip a little water
<b>Machine is smoking</b>	Heater may be bad	Send unit to factory for repair or call a Service Center
<b>Machine will not fill with water</b>	Check water supply	Make sure water is on and there are no obstructions in the water line or solenoid valve
<b>Deluxe Timer does not shut off at set temp</b>	Timer not installed inside steam shower/room	Deluxe Timer must be installed inside the steam room in order to detect the temperature. If the Deluxe Timer is installed outside the shower a remote temperature sensor must be purchased and factory installed on the timer
	Moisture Damage	Do visual check, uninstall and check for moisture damage
	Visual check OK	Send timer to factory for testing or call a Service Center
<b>TC-2 Timer does not shut off at set temperature - FOR COMMERCIAL APPLICATIONS ONLY</b>	Temperature sensor installed in a bad location	Verify that the temperature sensor inside the steam room is NOT installed near the door or a window. The sensor needs to be in a location that it will not be affected by constant changes such as a door opening and closing.
	Temperature sensor has been tampered with	Verify that the temperature sensor has not been moved or altered. It is common for sensors to be pushed into the wall, removed, or covered by foreign objects.
	Visual check OK	Send timer to factory for testing or call Service Center



MODEL # \_\_\_\_\_

DESCRIPTION \_\_\_\_\_

SERIAL # \_\_\_\_\_

**WATER SENSOR PROBE MAINTENANCE SCHEDULE:**

1st Cleaning Suggested: \_\_\_\_\_

2nd Cleaning Check: \_\_\_\_\_

3rd Cleaning Check: \_\_\_\_\_

\_\_\_\_\_

\_\_\_\_\_

\_\_\_\_\_

\_\_\_\_\_

\_\_\_\_\_

\_\_\_\_\_

\_\_\_\_\_

\_\_\_\_\_

\_\_\_\_\_

\_\_\_\_\_

\_\_\_\_\_

\_\_\_\_\_

\_\_\_\_\_

\_\_\_\_\_

\_\_\_\_\_

\_\_\_\_\_

\_\_\_\_\_

\_\_\_\_\_

\_\_\_\_\_

\_\_\_\_\_

\_\_\_\_\_

# WARRANTY

Steam-Whirl Products warrants its products to be free of defects in workmanship and material, under normal use and maintenance, for a period of (6) years from the date of original purchase.

Steam-Whirl Products liability under this warranty shall be limited to repair or replacement of products that have been determined to be defective in either materials or workmanship by an agent or representative of Steam-Whirl Products. If repair or replacement cannot be made on the premises by such agent or representative then the product should be sent to the service facility.

Technical Service  
STEAM-WHIRL PRODUCTS  
3775 W Teco Ave #5  
Las Vegas, NV 89118-6827  
800-232-7832

Products being sent to the service facility need to have prior approval and an RMA # (RETURNED MERCHANDISE AUTHORIZATION #) assigned. The products are to be packed in a well padded box, include RMA #, name, return address and daytime phone number along with a short description of problems. Mail or ship the unit, prepaid, to the above address.

If the product is returned for a defect other than in materials or workmanship a reasonable charge will be made for parts, labor and shipping.

**This warranty shall be void and/or does not cover the following:**

- 1) Charges for parts or labor incurred before delivery of product to the address above.
- 2) Any damage or defect caused by the installer, service company, user or any other person.
- 3) Installation is not in accordance with the installation instructions provided with the product and/or installation by a person other than a licensed electrician or plumber.
- 4) Deterioration due to normal wear and tear.
- 5) Misuse, accident, incorrect operation, lack of proper maintenance, acts of God.
- 6) Chemical corrosion.
- 7) Alteration of product in any way.
- 8) Exposure to outside weather conditions or temperatures.
- 9) Contact shows evidence of short circuit.
- 10) Damage incurred in transit. The user or installer must examine the product immediately on delivery, before installation and report any damage to the carrier and the seller.
- 11) Shipping costs to or from warranty service facility unless required by applicable law.
- 12) Repair or replacement of any installation materials including, but not limited to, tiles, marble, etc or costs relating to obtaining access for repair, removal or reinstallation of the product or a replacement product.

It is the responsibility of the user, installer or contractor to provide access for service and removal of the product, if necessary. Steam-Whirl Products is not responsible for any costs relating to accessing the product or its removal.

The dealer, distributor and/or installer is responsible for knowing the applicable building codes and the dealer and/or distributor should notify the installer of same or confirm that the installer is aware of the applicable building codes. Building codes vary from location to location and Steam-Whirl Products cannot be responsible for knowledge of such codes.

No other company or person has any authority to make any warranties or representations concerning Steam-Whirl Products or the products. Accordingly, Steam-Whirl Products is not responsible for any such warranties or representations.

Steam-Whirl Products has not made and does not make any warranty, either expressed or implied, about the condition, merchantability, design or operation of the product or its fitness for any particular use or purpose, or the quality of the materials or workmanship in the product or any other representation or warranty beyond the terms of this warranty.

Steam-Whirl Products shall not be liable for the user's incidental or consequential damages. User acknowledges that the price of the product would be higher if Steam-Whirl Products were liable for consequential or incidental damages.

Some states do not allow the exclusion or limitation, in whole or in part, of warranties or the exclusion of consequential or incidental damages, therefore the above limitation or exclusions may not be applicable to you.

Steam-Whirl Products warranty obligation shall be discharged upon tender of repair or replacement. User's refusal to accept the tender terminates Steam-Whirl Products' warranty obligation.

LISTED 16K3  
STEAMBATH  
EQUIPMENT



**FOR TECHNICAL ASSISTANCE CALL: 800-232-7832**  
**E-MAIL: [techsupport@steam-whirl.com](mailto:techsupport@steam-whirl.com)**



# STEAM ~ WHIRL

3775 W Teco Ave #5 Las Vegas, NV 89118  
(702) 270-2124 Fax (702) 270-6628

[www.steam-whirl.com](http://www.steam-whirl.com)  
e-mail: [swsales@steam-whirl.com](mailto:swsales@steam-whirl.com)