

# MOM690

## Microhmmeter



# MOM690



---

## Microhmeter

Measuring resistance is an important part of maintaining high-voltage breakers and disconnecting switches. Instruments that measure the resistance of high-current contacts and other transmission elements have been included in the Programma line of products for many years.

MOM690™ supplements our family of microhmeters. In addition to high current capacity, MOM690™ features microprocessor-based measurement, storage and reporting. The built-in software enables you to carry out an individual test or an entire series of tests and store the results.

With the optional MOMWin™ software you can also export the test results to a PC for further analysis and reporting. Ranges are set automatically, resistances are measured continually and test results can be automatically captured at a preset test current. What could be simpler?

After testing a breaker with a CT mounted in its current circuit, e.g. dead tank and GIS breakers, some standards recommended that the CT is demagnetized. This troublesome task can be accomplished quickly and easily thanks to the MOM690's AC output. The AC output can also be used as a general multi-purpose current source in different applications.

## Application example

### IMPORTANT!

Read the User's manual before using the instrument.

### Measuring the resistance of a breaker

1. Make certain the line is de-energized on both sides of the breaker.
2. Ground the breaker on one side and make certain it is closed.
3. Ground the microhmmeter.
4. Make certain the microhmmeter's ON/OFF switch is OFF while making connections.
5. Connect the current cables to the DC+ and COM terminals and the sensing cables to the sensing inputs to both sides of the breaker, making sure that the polarities match properly.  
**IMPORTANT:** The sensing cables must be connected inside the current cables. Otherwise the test data will be incorrect. See Fig.
6. Switch on the MOM690.
7. Select "AUTO" or "MAN" with the <FUNC>-button.
8. Set output current to zero to start the measurement.
9. Increase the current to the desired value (600 A for example).
10. Read the resistance value.

### Measuring resistance at busbar joints

1. Make certain the line is de-energized and the test object is grounded.
2. Ground the microhmmeter.
3. Make certain the microhmmeter's ON/OFF switch is OFF while making connections.
4. Connect the microhmmeter's current cables to the test object. Do not connect the sensing cables. Measurement will be done manually using an external portable voltmeter.
5. Switch on the MOM690.
6. Select "MAN" with the <FUNC>-button.
7. Set output current to zero to start the measurement.
8. Increase the current to the desired value (100 A for example).
9. Using an external voltmeter, measure the voltage drop across each contact element within every section of the busbar being tested. The voltmeter must be set to DC.
10. Calculate the actual resistance.

**Example:** If the voltage drop is 0.0067 V at a current of 100 A, the resistance will be  $0.0067/100 \Omega$ , i.e.  $67 \mu\Omega$ .

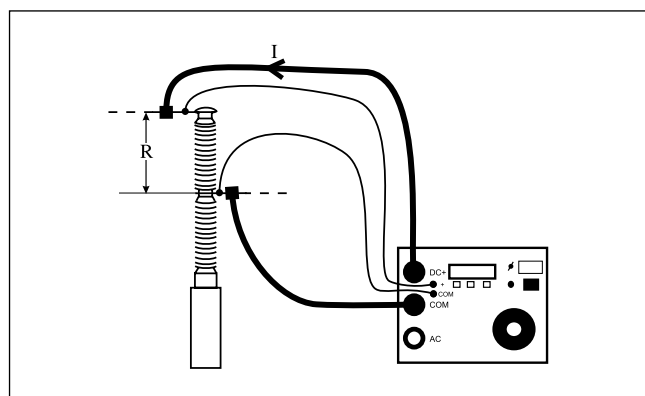

Measuring the resistance of a breaker

## Optional accessories

### PC Software MOMWin

An optional Windows® program named MOMWin is available for MOM690. It can be used to control measurement, analyse the results and report the results from a PC. It also enables you to retrieve test results stored previously in MOM690.

All readings are saved in ASCII-format and can be easily exported to your favourite spreadsheet program. Results can be presented in table or diagram form in MOMWin.

The program runs in Windows® 95, 98, NT, 2000 or XP. Minimum requirement is a 486 computer with 8 MB of RAM.

Incl. serial cable for RS-232 port.

### Cable set 15 m (49 ft)

2 x 15 m (49 ft), 95 mm<sup>2</sup> (current cables).

2 x 15 m (49 ft), 2.5 mm<sup>2</sup> (sensing cables).

**Weight:** 29.4 kg (64.8 lbs)

### Cable extension sets

Since all current cables have bayonet connectors, standard cables can be easily prolonged with 5- or 10-metre extension sets if so desired. In situations requiring high currents and long cable lengths, heavier cable sets may be necessary however.

#### Extension cable set No. 1

2 x 5 m (16 ft), 50 mm<sup>2</sup> (current cables).

2 x 10 m (33 ft), 2.5 mm<sup>2</sup> (sensing cables).

**Weight:** 7.5 kg (16.5 lbs)

#### Extension cable set No. 2

2 x 10 m (33 ft), 50 mm<sup>2</sup> (current cables).

2 x 15 m (49 ft), 2.5 mm<sup>2</sup> (sensing cables).

**Weight:** 15 kg (33 lbs)

### Calibration shunt

An optional calibration shunt (600 A/60 mV) can be ordered for MOM690, that enables you to make certain that the instrument readings remain correct.

### Transport case XL

With space for the standard 5 m cable set + extension cable set No. 1 or No. 2.

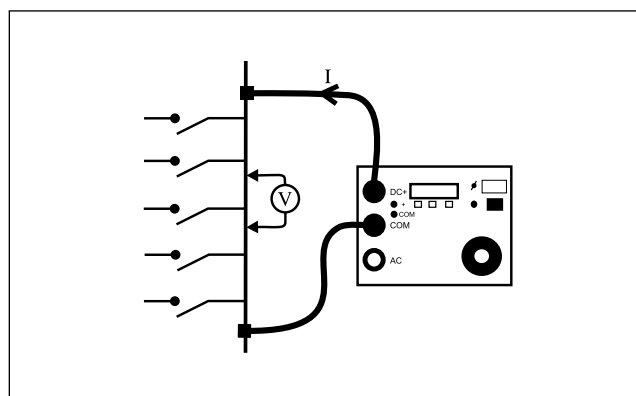

Measuring resistance at busbar joints

## Specifications MOM690

Specifications are valid at nominal input voltage and an ambient temperature of +25°C, (77°F). Specifications are subject to change without notice.

### Environment

|                                |   |
|--------------------------------|---|
| <i>Application field</i>       | The instrument is intended for use in high-voltage substations and industrial environments. |
| <i>Temperature</i>             |   |
| <i>Operating</i>               | 0°C to +50°C (32°F to +122°F)   |
| <i>Storage &amp; transport</i> | -40°C to +70°C (-40°F to +158°F)  |
| <i>Humidity</i>                | 5% – 95% RH, non-condensing   |

### CE-marking

|            |   |
|------------|---|
| <i>LVD</i> | Low Voltage Directive 73/23/EEC am. by 93/68/EEC                    |
| <i>EMC</i> | EMC Directive 89/336/EEC am. by 91/263/EEC, 92/31/EEC and 93/68/EEC |

### General

|                                    |  |
|------------------------------------|--|
| <i>Mains voltage</i>               | 115/230 V AC, 50/60 Hz   |
| <i>Power consumption (max)</i>     | 115 V, 5980 VA (at 600 A output)<br>230 V, 9660 VA                           |
| <i>Protection</i>                  | Miniature circuit breaker, thermal fuse, software                            |
| <i>Dimensions</i>                  |  |
| <i>Instrument</i>                  | 350 x 270 x 220 mm<br>(13.8" x 10.6" x 8.7")                                 |
| <i>Transport case</i>              | 610 x 290 x 360 mm<br>(24.0" x 11.4" x 14.2")                                |
| <i>Weight, 115 V model</i>         | 24 kg (52.9 lbs)<br>38.9 kg (85.7 lbs) with accessories and transport case   |
| <i>Weight, 230 V model</i>         | 23.7 kg (52.2 lbs)<br>38.6 kg (85.1 lbs) with accessories and transport case |
| <i>Available languages</i>         | English, French, German, Spanish, Swedish                                    |
| <i>Current cables</i>              | 2 x 5 m (16 ft), 50 mm <sup>2</sup>  |
| <i>Sensing cables</i>              | 2 x 5 m (16 ft), 2.5 mm <sup>2</sup>   |
| <i>Optional current cable sets</i> |  |
| <i>Ext.1</i>                       | Extension 2 x 5 m, 50 mm <sup>2</sup>  |
| <i>Ext.2</i>                       | Extension 2 x 10 m, 50 mm <sup>2</sup>                                       |
| 2 x 15 m (49.2 ft)                 | 95 mm <sup>2</sup>   |

### Measurement section

#### Ammeter

|                   |  |
|-------------------|--|
| <i>Range</i>      | 0 – 800 A  |
| <i>Resolution</i> | 1 A  |
| <i>Inaccuracy</i> | 100 – 800 A, ±1% of reading + 1 digit<br>50 – 99 A, ±(2% of reading + 2 digits)<br>0 – 49 A, not specified |

#### Resistance

|                   |  |
|-------------------|--|
| <i>Range</i>      | 0 – 200 mΩ, > 200 mΩ not specified   |
| <i>Resolution</i> | 1 μΩ   |
| <i>Inaccuracy</i> | 100 – 800 A, ±1% of reading + 1 digit<br>50 – 99 A, ±(2% of reading + 2 digits)<br>0 – 49 A, not specified |

### Max. load resistance / current, 115 V model

| <i>Cable set</i>    | <i>Standard</i> | <i>Standard + Ext. 1</i> | <i>Standard + Ext. 1</i> | <i>2 x 15 m 95 mm<sup>2</sup></i> |
|---------------------|-----------------|--------------------------|--------------------------|-----------------------------------|
| <b>At 300 A</b>     | 10 mΩ           | 6 mΩ                     | 3 mΩ                     | 10 mΩ                             |
| <b>Max. current</b> | 575 A           | 420 A                    | 360 A                    | 540 A                             |

### Max. load resistance / current, 230 V model

| <i>Cable set</i>    | <i>Standard</i> | <i>Standard + Ext. 1</i> | <i>Standard + Ext. 1</i> | <i>2 x 15 m 95 mm<sup>2</sup></i> |
|---------------------|-----------------|--------------------------|--------------------------|-----------------------------------|
| <b>At 300 A</b>     | 18 mΩ           | 14 mΩ                    | 11 mΩ                    | 18 mΩ                             |
| <b>At 600 A</b>     | 3.0 mΩ          |                          |                          | 1.8 mΩ                            |
| <b>Max. current</b> | 750 A           | 570 A                    | 480 A                    | 690 A                             |

### Output DC (CAT I), 115 V model

| <i>Current (A)</i> | <i>Voltage (V)</i> | <i>Max. load time</i> | <i>Input current (A)</i> |
|--------------------|--------------------|-----------------------|--------------------------|
| 0                  | 7.3                | –                     | 0.8                      |
| 50                 | 6.9                | 30 min.               |                          |
| 100                | 6.4                | 10 min.               | 10                       |
| 200                | 5.5                | 90 s                  | 19                       |
| 300                | 4.8                | 50 s                  |                          |
| 400                | 3.9                | 30 s                  | 38                       |
| 500                | 3.0                | 15 s                  |                          |
| 575 <sup>1)</sup>  | 2.5                | 10 s                  |                          |
| 600                | 2.2                | 8 s                   | 52                       |
| 700                | 1.5                | 5 s                   |                          |
| 800 <sup>2)</sup>  | 0.9                | –                     |                          |

1) Maximum current with standard cables 2 x 5 m 50 mm<sup>2</sup>

2) At 800 A and above, instant shut off

Note: The above figures shows maximum load time from cold state 25°C. They are not valid for repeated tests

### Output AC (CAT I), 115 V model

| <i>Current (A)</i> | <i>Voltage (V)</i> | <i>Max. load time</i> | <i>Rest time</i> |
|--------------------|--------------------|-----------------------|------------------|
| 0                  | 8.7                | Cont.                 | –                |
| 660                | 3.5                | 2 s                   | 4 min.           |

Note: The DC and AC outputs must not be loaded at the same time.

### Output DC (CAT I), 230 V model

| <i>Current (A)</i> | <i>Voltage (V)</i> | <i>Max. load time</i> | <i>Input current (A)</i> |
|--------------------|--------------------|-----------------------|--------------------------|
| 0                  | 9.4                | –                     | 0.4                      |
| 50                 | 9.0                | 30 min.               |                          |
| 100                | 8.6                | 10 min.               | 6                        |
| 200                | 8.0                | 90 s                  |                          |
| 300                | 7.2                | 50 s                  |                          |
| 400                | 6.4                | 40 s                  |                          |
| 500                | 5.7                | 30 s                  |                          |
| 600                | 5.0                | 15 s                  | 33                       |
| 700                | 4.3                | 8 s                   |                          |
| 750 <sup>1)</sup>  | 3.8                | 5 s                   |                          |
| 800 <sup>2)</sup>  | 3.6                | –                     | 42                       |

1) Maximum current with standard cables 2 x 5 m 50 mm<sup>2</sup>

2) At 800 A and above, instant shut off

Note: The above figures shows maximum load time from cold state 25°C. They are not valid for repeated tests

### Output AC (CAT I), 230 V model

| <i>Current (A)</i> | <i>Voltage (V AC)</i> | <i>Max. load time</i> | <i>Rest time</i> |
|--------------------|-----------------------|-----------------------|------------------|
| 0                  | 11.2                  | Cont.                 | –                |
| 660                | 4.5                   | 2 s                   | 4 min.           |

Note: The DC and AC outputs must not be loaded at the same time.

- ❶ Grounding terminal
- ❷ Connection for mains voltage
- ❸ Miniature circuit breaker for mains
- ❹ Switch for mains voltage
- ❺ Variable transformer
- ❻ AC current output
- ❼ Common output terminal
- ❽ DC current output
- ❾ Voltage measurement input
- ❿ Display
- ⓫ Setting selector
- ⓬ Function selector
- ⓭ Interrupts current and toggles the display between resistance and voltage
- ⓮ RS 232 Serial interface



Information about current generation or memory location. \_\_\_\_\_

Value of the generated current. \_\_\_\_\_

Indicates whether the current is above (<) or below (>) a preselected value. \_\_\_\_\_

Selected test current for "Auto"/"DC Off". Scroll using the <▲>-button. \_\_\_\_\_

Selected function. Scroll using the <FUNC>-button. \_\_\_\_\_

Shows the measured resistance or voltage value. Toggle by pressing the <Ω>-button. \_\_\_\_\_



Cable set and current shunt

## Ordering information

Art.No.

### MOM690

Complete with:  
 Cable set standard GA-05055  
 Ground cable GA-00200  
 Transport case GD-00182

|                     |                 |
|---------------------|-----------------|
| 115 V Mains voltage | <b>BB-41190</b> |
| 230 V Mains voltage | <b>BB-42390</b> |

### Optional accessories

|                                    |                 |
|------------------------------------|-----------------|
| PC Software MOMWin                 |                 |
| Incl. serial cable for RS-232 port | <b>BB-8010X</b> |
| Cable set 15 m (49 ft)             | <b>GA-09155</b> |
| Extension cable set No. 1          | <b>GA-05057</b> |
| Extension cable set No. 2          | <b>GA-05107</b> |
| Calibration shunt                  | <b>BB-90024</b> |
| Transport case XL                  | <b>GD-00042</b> |

NOTICE OF COPYRIGHT & PROPRIETARY RIGHTS

© 2008, Programma Electric AB. All rights reserved.

The contents of this document are the property of Programma Electric AB. No part of this work may be reproduced or transmitted in any form or by any means, except as permitted in written license agreement with Programma Electric AB.

Programma Electric AB has made every reasonable attempt to ensure the completeness and accuracy of this document. However, the information contained in this document is subject to change without notice, and does not represent a commitment on the part of Programma Electric AB.

TRADEMARK NOTICES

Megger® and Programma® are trademarks registered in the U.S. and other countries.

All other brand and product names mentioned in this document are trademarks or registered trademarks of their respective companies.

Programma Electric AB is certified according to ISO 9001 and 14001.



---

Programma Electric AB  
Eldarvägen 4  
Box 2970  
SE-187 29 TÄBY  
Sweden

T +46 8 510 195 00  
F +46 8 510 195 95  
info@programma.se  
www.programma.se