



Model 410 Series
Syringe Pumps
User's Manual

WEEE/RoHS Compliance Statement

EU Directives WEEE and RoHS

To Our Valued Customers:

We are committed to being a good corporate citizen. As part of that commitment, we strive to maintain an environmentally conscious manufacturing operation. The European Union (EU) has enacted two Directives, the first on product recycling (Waste Electrical and Electronic Equipment, WEEE) and the second limiting the use of certain substances (Restriction on the use of Hazardous Substances, RoHS). Over time, these Directives will be implemented in the national laws of each EU Member State.

Once the final national regulations have been put into place, recycling will be offered for our products which are within the scope of the WEEE Directive. Products falling under the scope of the WEEE Directive available for sale after August 13, 2005 will be identified with a "wheelie bin" symbol.

Two Categories of products covered by the WEEE Directive are currently exempt from the RoHS Directive - Category 8, medical devices (with the exception of implanted or infected products) and Category 9, monitoring and control instruments. Most of our products fall into either Category 8 or 9 and are currently exempt from the RoHS Directive. We will continue to monitor the application of the RoHS Directive to its products and will comply with any changes as they apply.

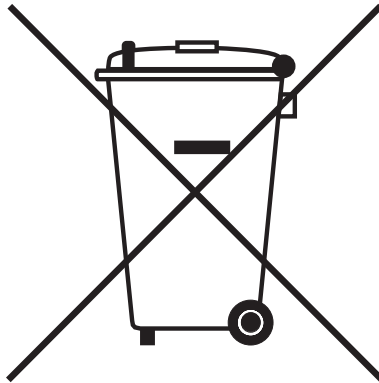

- **Do Not Dispose Product with Municipal Waste**
 - **Special Collection/Disposal Required**

KDS Model 410 Series Syringe Pumps

Contents

Specifications.....	3
General Safety Summary.....	4
General Description	5
Features.....	5-7
Operating Instructions	7-18
Power Switch	7
Syringe Loading	8-10
Withdrawal Operation	10
Units Setting	11
Rate Setting.....	11
Power Up	11
Run/Stop	11
Change or Review Volume Setting While Running	12
Mode Selection	12
Infusion	
Withdrawal	
Infusion/Withdrawal	
Withdrawal/Infusion	
Continuous	
Manual Stall Setting and Microliter Syringes	13
Glass Syringes	13
Clearing a Stall Condition	14
NV Ram Failure	14
RS232 Connections.....	14
RS232C Commands	15-18
Programmable Option	19-27
General Information	19
Features.....	20
Menu Operation	21-22
Running the Program.....	23
Commands and Responses	24-27
RS232 Commands.....	28
TTL Specifications	29
Fuses.....	29
Maintenance	30
Standard Table of Syringe Diameters	31

KDS Model 410 Series Syringe Pumps

Japanese Table of Syringe Diameters	32
Standard Minimum and Maximum Flow Rates.....	33
Japanese Minimum and Maximum Flow Rates	34
Limited Warranty.....	35

KDS Model 410 Series Syringe Pumps

Specifications

Model	410 Series
Syringe Size	10 microliter to 140 milliliter
Electrical Rating	US model 115 V~, 0.25 A CE model 230 V~, 0.16 A
Fuse	5 x 20 mm, 250 V~, Slow Blow, 0.25 A
Voltage Operating Range	US model 100-120 V~, 50/60 Hz CE model 200-240 V~, 50/60 Hz
Drive Mechanism	Microprocessor controlled stepper motor 1/2 to 1/16 microstepping, driving a leadscrew through a belt and pulley drive mechanism
Pusher Advance Per Microstep	(1/16 step) - 0.165 mm (or 0.0000064 in)
Volume Per Microstep	(1/16) with 60 ml BD syringe - 0.0919 μ l
Stepping Rate:	
Maximum	1600 (1/2 step)/sec
Minimum	1 (1/16 step) /120 secs
Linear Travel Rate:	
Maximum	12.67 cm/min
Minimum	4.95 x 10 ⁻⁴ cm/hr
Flow Rate Range	2.757 μ l/hr to 70.56 ml/min (60 ml syringe)
Nominal Linear Force	>100 lbs
Dimensions, H x W x D	15 x 28 x 24 cm (6 x 11 x 9.5 in)
Weight	6.4 Kg (14 lbs)

Atmospheric Specifications

Temperature	5°C -40°C (41°F - 104°F)
Humidity	20% - 80% RH
Mode of Operation	Continuous
Classification	Class I
Pollution Degree	2
Installation Category	II
Output	N/A
Physiological Effects	N/A
Cooling Conditions	No special considerations
Mechanical Stability	No special considerations
Protective Packaging	No special considerations
Earth Terminals	No External connections required
Removable Protective Means	N/A
Supplier Name	KD Scientific, Inc.
Address	84 October Hill Road, Holliston, MA 01746-1388

KDS Model 410 Series Syringe Pumps

General Safety Summary

Please read the following safety precautions to ensure proper use of your syringe pump. To avoid potential hazards and product damage, use this product only as instructed in this manual. If the equipment is used in a manner not specified by the manufacturer, the protection provided by the equipment may be impaired.

To Prevent Hazard or Injury:

Use Proper Line Cord

Use only the line cord shipped with the product and make sure line cord is certified for country of use.

Ground the Product

This product is grounded through the grounding conductor of the power cord. To avoid electric shock, use only approved line cord with the product and insure it is connected to earth ground.

Make Proper Connections

Make sure all connections are made properly and securely.

Observe all Terminal Ratings

Review the operating manual to learn the ratings on all connections.

Avoid Exposed Circuitry

Do not touch any electronic circuitry inside of the product.

Do Not Operate with Suspected Failures

If damage is suspected on or to the product do not operate the product. Contact qualified service personnel to perform inspection.

Observe all Warning Labels on Product

Read all labels on product to ensure proper usage.



CAUTION
Refer to Manual



*Protective Ground
Terminal*

CAUTION

This pump is not registered with the FDA and is not for clinical use on human or veterinary patients. It is intended for research use only.



KDS Model 410 Series Syringe Pumps

General Description

This manual applies to the KDS410 series infusion/withdrawal pump.

Operation of the pump is simplified by using a keypad to select features from a menu on the alphanumeric display.

All control functions are performed automatically by the pump microcontroller and are based on the syringe diameter and linear motion of the pusher block to deliver a known volume. After entering the syringe diameter, either directly or from a table in memory, a dispense volume and flow rate can be entered, and then all calibration and control functions are performed by the pump automatically.

Features

1) Syringe identification

Look up Table

The pump contains a table of standard syringes arranged by manufacturer, material and size. Once the syringe is identified in the table the pump automatically enters the appropriate diameter.

Direct Entry

If the syringe used is not included in the table, the internal diameter of the syringe barrel can be measured in millimeters and entered directly from the keypad.

2) INFUSION AND REFILL RATES

The infusion rate and, where applicable, the withdrawal rate can be set independently and can be changed while the pump is running. After the operating mode selection is made the program will prompt only for the relevant rates associated with that mode.

3) VOLUME

A target volume can be entered for infusion and refill independently, and the pump automatically stops when this volume is reached. The pump displays an initial volume of zero and increases as the dispense proceeds to the target volume. The target volume can be reviewed or changed as the pump continues to operate.

KDS Model 410 Series Syringe Pumps

Features (continued)

4) MODES OF OPERATION

Infusion

Rate and volume settings: pump infuses to the set volume and stops.

Rate setting only: pump runs until manually stopped or stalls.

Withdrawal

Rate and volume settings similar to above.

Infusion/withdrawal

Infusion automatically followed by withdrawal. Rate and volume settings can be made independently for infusion and withdrawal, hence the pump can infuse at one rate and volume and then change to a different withdrawal flowrate and volume setting.

Withdrawal/infusion

Withdrawal immediately followed by infusion. Separate settings for rate and volume can be made for withdrawal and infusion.

Continuous operation

The pump cycles from infusion to withdrawal continuously. The volume is identical in infuse and withdrawal directions.

Note: The displayed menu which prompts the operator for Rate and Volume settings changes with Mode selection. For convenience, only the relevant settings associated with the selected mode are prompted. For example, in the Withdrawal / Infusion mode the menu prompts for withdraw and then infuse volumes, followed by withdraw and infuse rates. In Infusion only mode, the menu prompts only for infusion volume and infusion rate. In the Continuous mode only one volume is prompted for followed by infusion and withdrawal flow rates.

5) RS232C INTERFACE

Multiple pumps can be controlled in a "daisy chain" by a single PC.

Programming is reduced to a small number of simple commands.

6) TTL

Input and output controls are available, such as, direction change, run indicator, footswitch or timer control, and valve or relay actuation.

KDS Model 410 Series Syringe Pumps

Features (continued)

7) STALL DETECTION

The motor is monitored by an optical encoder to confirm the programmed movement. If the back pressure increases due to jamming or flow restriction then the motor may stall. Stall detection by the encoder results in a pump shutdown. The display will read " Stalled ". The Stall message can be cleared with the Select key.

8) POWER DISRUPTION

When power is returned after a temporary power disruption the pump can be programmed to resume operation or remain stopped. However, if a dispense volume is set then the pump always remains stopped.

9) NON-VOLATILE MEMORY

All operational settings are stored in non-volatile memory for convenience, and are used to set the pump when first switched on.

10) SELECTION OF RATE AND VOLUME UNITS

Units of volume (μ l or ml) and flowrate (μ l/ml per min/hr) can be changed if required.

11) POWER SAVER MODE

When the pump is not running the unit goes into power saver mode. This automatically prevents heat build up in the pump due to the motor being continually energized.

Operating Instructions

POWER SWITCH

The power switch is located in the middle of the rear panel.

KDS Model 410 Series Syringe Pumps

Operating Instructions (Continued)

SYRINGE LOADING

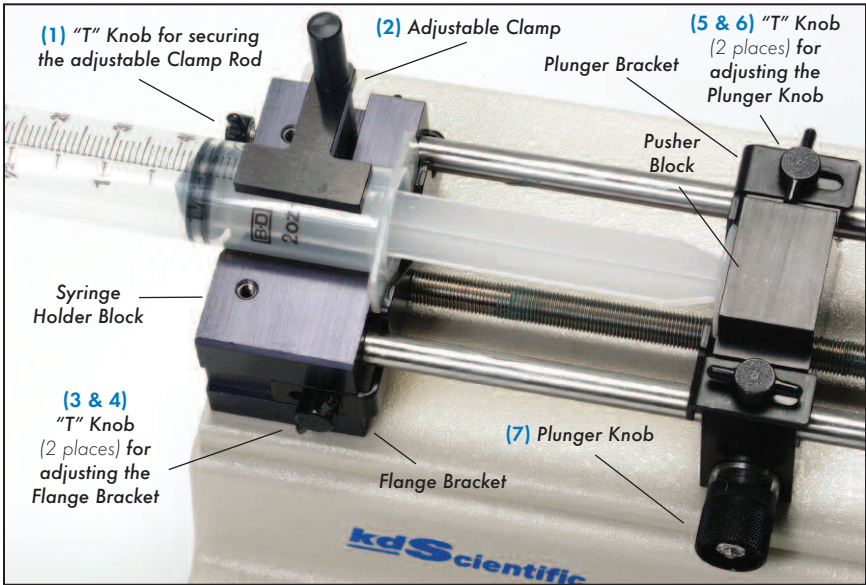

Clamping for Plastic & Glass Syringes

Using the Adjustable Clamp for Plastic & Glass Syringes

1. Loosen "T" knob (1) allows the user to lift and rotate the adjustable clamp (2) out of the way.
2. Loosen "T" knobs (3 & 4) and slide the Flange Bracket towards the Pusher Block.
3. Loosen "T" knobs (5 & 6) and move the Plunger Bracket towards the Syringe Holder Block.
4. Rotate the Pusher Block Knob (7) until it snaps into place. This will disengage the Pusher Block and allow the user to position the block to accept the syringe.
5. Place the syringe in the holder, making sure the flange is resting against the Syringe Holder Block and the plunger is against the Pusher Block. Make sure the plunger flange rests between the bracket and the pusher block, and the syringe flange rests between the flange bracket and the syringe holder block for proper operation.
6. Rotate the Adjustable Clamp (2) until it rests on the Syringe barrel.
7. While pushing down on the Adjustable Clamp (2), tighten the "T" knob (1).

KDS Model 410 Series Syringe Pumps

Operating Instructions (Continued)

SYRINGE LOADING (Continued)

- Slide the Flange Bracket towards the Syringe Flange and tighten the "T" knobs (3 & 4).
- Slide the Plunger Bracket towards the Pusher Block, and tighten the "T" knobs (5 & 6).
- Engage the Pusher Block by pulling the Knob (7) out and rotate the knob 90° clockwise.

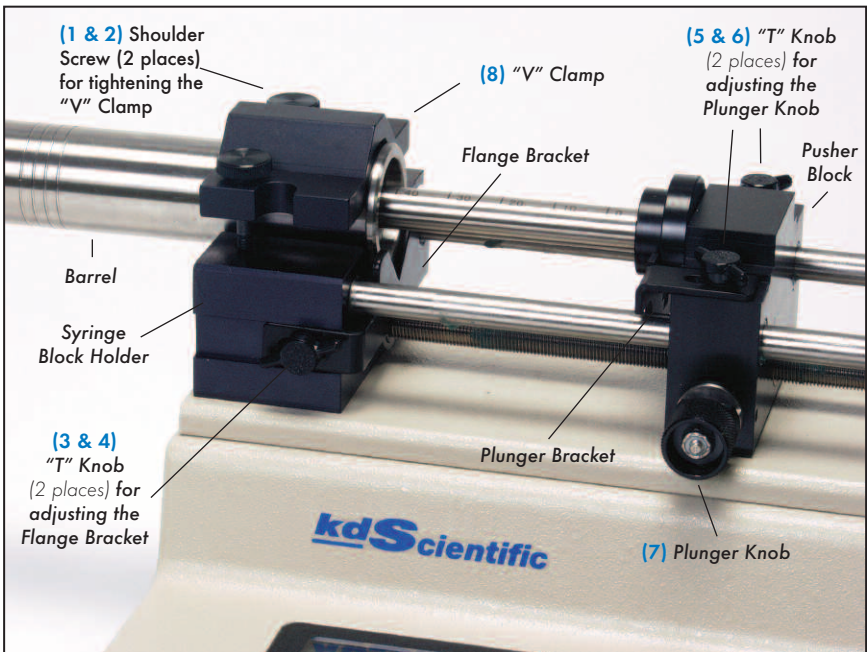

Clamping for Stainless Steel Syringes

Using the "V" Clamp for Stainless Syringes

- Unscrew and remove the two Shoulder Screws (1 & 2) and remove the "V" clamp (8).
- Loosen the two "T" knobs (3 & 4) and slide the Flange Bracket towards the Pusher Block.
- Loosen the "T" knobs (5 & 6) and slide the Plunger Bracket towards the Syringe Holder Block.
- Disengage the Pusher Block by rotating the Plunger Knob (7) until it snaps into place.

KDS Model 410 Series Syringe Pumps

Operating Instructions (Continued)

SYRINGE LOADING (Continued)

5. Place the syringe in the holder and place the “V” Clamp (8) inverted, over the barrel of the syringe, and replace the Shoulder Screws (1 & 2). Tighten the Shoulder screws. Make sure the flange of the syringe is resting against the Syringe holder block, between the clamp and the Syringe Block, and the Plunger Flange is between the Pusher Bracket and the Pusher Block.
6. Slide the Flange Bracket towards the Syringe Flange and tighten the two “T” Knobs (3 & 4).
7. Slide the Plunger Bracket towards the Syringe Plunger and the Pusher Block and tighten the two “T” knobs (5 & 6).
8. Engage the Pusher Block by pulling the Plunger Knob (7) out and rotate the knob 90° clockwise.

To simplify syringe loading, the pusher block can be disengaged from the leadscrew by turning the knob (7) and manually moved along the guide rods. Alternately, the **Fast forward**, **Fast reverse** feature can be used (press Run and respective Arrow key simultaneously).

KDS410 WITHDRAWAL OPERATION

For withdrawal, or refill operation, the syringe plunger and barrel flange must be secured by the supplied brackets.

KDS Model 410 Series Syringe Pumps

Operating Instructions (Continued)

UNITS SETTING

prompt: Vol.: 00.00 ml <

The units displayed can be changed if required.

- 1) Use the RIGHT arrow key to move the pulsing indicator to the units displayed.
- 2) Continue to use the RIGHT arrow key to scroll through the possible units.
- 3) The LEFT arrow key will move the active display back to the numerical value.
- 4) When the correct value and units are displayed press **enter**.

Possible units are:

- μ l and ml
- microliter and milliliter
- μ l/m, μ l/h and ml/m, ml/h
- μ l or ml per minute or hour

RATE SETTING

Display reads: Rate 00.01 ml/h >

- 1) Enter the flowrate value required with the numerical keypad
- 2) If necessary, change the units using the \rightarrow key to move to and scroll through the possible units.
- 3) When the displayed settings are correct press **enter**.

Note: If the number entered exceeds the maximum flow rate possible then the pump displays the maximum feasible rate. To continue enter a rate smaller than the maximum.

Note: To check the maximum possible rate enter 9's to the required decimal position. For example, enter 99.9 and the maximum displayed is 12.3 whereas, if 99.99 is entered, then the maximum displayed is 12.34.

POWER UP **run or stop**

This option is only applicable when **no dispense volume** is selected. When power returns after an interruption the pump can resume operation (select RUN) or remain stopped (select STOP).

If the pump resumes operation the rate display will flash to indicate that a power interruption has occurred. Press **select** to clear the display to resume normal operation.

RUN/STOP

After all settings are made, the pump can be started or stopped by a single press of the **run/stop** key. During a volume dispense the **stop** acts as a "pause" and **run** will resume the dispense.

KDS Model 410 Series Syringe Pumps

Operating Instructions (Continued)

CHANGE OR REVIEW VOLUME SETTING WHILE RUNNING

While the pump continues to run press **select** to return to the main menu. Scroll through the menu and **select** Volume to display the set dispense volume.

- a) **No volume change**
Press **select**. The display returns to the incrementing display volume.
- b) **Volume change**
 - 1) Make the changes with the numerical keypad and **enter**.
 - 2) The display moves to RATE, permitting a change if required. Use the numerical keypad and **enter** to make changes (or leave unchanged). The pump immediately changes to the new flowrate, if changed, and the volume continues to increment, uninterrupted by the review process, to new target dispense volume when it will stop automatically.

Note: If the volume is changed to a volume **smaller** than the volume already accumulated then the pump will stop as soon as the new, smaller target volume is entered.

MODE SELECTION

Mode selection is available only on infusion/withdrawal models.

Select MODE from the main menu and then scroll through the options displayed and **select** the mode required.

Possible modes are: **infusion, withdrawal, infusion / withdrawal, withdrawal / infusion, continuous**

Note: for bi-directional modes a volume is required.

infusion

Pump infuses at the set rate and stops automatically when the target volume is reached. The pump can be manually stopped and restarted at any time, that is, the dispense is paused and, when restarted will continue to the set dispense volume.

withdrawal

Pump withdraws at the set rate to the set volume.

infusion / withdrawal

The pump first infuses and when the target volume is reached it immediately changes direction and withdraws. The volume settings for infusion and withdrawal can be different, as can the infusion and withdrawal flow rates.

withdrawal / infusion

The pump runs first in the withdrawal direction and then automatically changes to the infusion direction. Different settings of rate and volume for withdraw and infuse are permitted.

continuous

The pump first infuses and then withdraws, and then cycles continuously. Only one volume setting for infusion and withdrawal is permitted. If the pump is matched to a valve, which is actuated by a TTL pulse from the pump, this mode can be used to infuse and then refill the pump for continuous operation.

The menu now prompts for volume and rate settings relevant to the mode selected.

KDS Model 410 Series Syringe Pumps

Operating Instructions (Continued)

MANUAL STALL SETTING AND MICROLITER SYRINGES

(Not recommended for small syringes)

A movable collar, located on the rear guide rod of infusion only pumps, can be set to limit travel of the pusher block. The block moves until stalled against the collar when the electro-optical sensor detects the stall and stops the pump.

Damage to the fine wire plungers of microliter syringes caused by forcing the plunger into the end of the syringe barrel can be prevented by careful adjustment of the collar position.

GLASS SYRINGES

In the withdrawal mode the retaining bracket on the pusher block clamps on the head of the plunger. With some glass syringes the corners of the plunger head are rounded and this may cause the head to ride up out of the retaining bracket.

Similarly in the infusion mode the rounded corners of the syringe barrel flange cause a tendency for the syringe barrel to ride up out of the syringe holder.

To give a more secure, flatter surface to clamp against, an O-ring or metal collar can be placed over the barrel and pressed against the flange.

WARNING: *This version pump has enough force to break glass syringes and/or bend thin plungers. Stainless steel syringes should be used in this version pump. Plastic syringes may be used but may fatigue under pressure.*

KDS Model 410 Series Syringe Pumps

Operating Instructions (Continued)

CLEARING A STALL CONDITION

Should a stall occur the pump motor is stopped to prevent damage.

To clear the display press **select**.

To move the stalled mechanism use the **fast forward** or **fast reverse** to move the pusher block. Using the fast forward or fast reverse feature is not only the most simple way to deal with the stall, it also reduces potential damage to the cam mechanism which releases the halfnut from the leadscrew.

NV Ram Failure

If the settings in the non-volatile memory become corrupted the display will read "NV Ram Failure" and the pump will not operate.

To recover from this condition the pump must be powered down and then turned on again after a few seconds delay. The pump will be re-initialized to the default settings and can now be programmed as normal.

If the above fails to work the "NV Ram Failure" message can also be cleared by pressing **select** and programming a new flow rate. The pump should then be turned off and on to save the settings.

RS232C

The RS232 connections are made through two modular telephone connectors, labeled IN and OUT, located on the rear panel.

A single PC can control up to 100 pumps via a "daisy chain" using the IN and OUT connectors. When using the daisy chain each pump must be assigned an address and set to the same baud rate. A splitter may be required with greater than 50 pumps.

When controlled via RS232 the pump will still respond to keypad commands but will not respond to keypad and RS232 commands simultaneously. All RS232 command settings, similar to keypad settings, are stored in non-volatile memory.

Select RS232 from the main menu.

Baud Rate 300, 1200, 2400, 4800, 9600

The available baud rates will now be displayed and can be selected using the **arrow** and **select** keys.

The display now prompts for assignment of a pump address.

Address

If, no address is assigned then the pump defaults to a 0 setting.

All pumps with the same address respond simultaneously to the same commands.

Use the **→** key to enter an address, 0 - 99 and press **select** to return to the main menu.

KDS Model 410 Series Syringe Pumps

Operating Instructions (Continued)

RS232 COMMANDS

RS232 is used for remote computer control of up to 100 pumps, identified with an address from 0 to 99 and set to the correct baud rate. Each pump can be controlled either from the keypad or via RS232 at all times, but the pump can only respond to one command at a time. When under RS232 control the display reads "REMOTE". All settings made via RS232 are stored in non-volatile memory.

To move the pump from Remote (RS232) to keypad control press **select**.

After each command is received and executed by the pump the pump responds with a message and a prompt.

Commands and Responses

Commands are not case sensitive.

After each command is received and executed the pump responds with prompt sequence:

abbreviations:

<CR>	= carriage return
<LF>	= line feed
<SP>	= space
<NSP>	= no space

a) Commands:

Address<SP>command<CR><LF>

b) Response:

<CR><LF>address<NSP>prompt

For example:

Query pump 2 for withdrawal flow rate (which is 0.2 ml/minute)

command: 2<SP>ratew?<CR><LF>

response: 0.2<SP>ml/m<CR><LF>2:

Query a single pump for infusion flow rate (which is 0.2 ml/minute)

command: ratei?<CR><LF>

response: 0.2<SP>ml/m<CR><LF>:

KDS Model 410 Series Syringe Pumps

Operating Instructions (Continued)

RS232 COMMANDS (continued)

Prompts	>	running in infusion direction
	<	withdrawing
	:	stopped
	NA	not applicable
	E	error (see error? command)
carriage return <CR>		All pumps chain interpret this as a stop command
pump address<CR>		Pump with the specified address responds with a prompt
pump address (optional), command<CR>		Pump at the address executes the command and then responds with a prompt.

Note: If there are multiple pumps in the daisy chain and a pump address is not used then all pumps will respond to the non-specific command and return prompts. Multiple prompts results in a communications breakdown.

Pump commands and responses

Note that mode selection and withdrawal and continuous mode commands are recognized only by the infusion/withdrawal models.

run	Starts pump running to present settings, returns prompt > or < If already running command is ignored.
stop	Stops pump if running, otherwise is ignored. Returns prompt :
dia nn.nn	Sets syringe diameter in millimeters. n = 0 to 9
run?	Query run status, returns prompt.
del?	Queries delivered volume. (Requires a dispense volume to be set). Response: nnnnn<SP>u/u Where nnnnn is ., 0 to 9 u are units, μ l or ml
dia?	Requests present diameter setting. Response: nn.nn Where n = 0 to 9 units always millimeters
ratei?	Queries infusion rate. Response: nnnnn<SP>u/u Where nnnnn is ., 0 to 9 u/u are units, μ l/m, μ l/h, ml/m, or ml/h
ratew?	Queries withdrawal rate. Response: nnnnn<SP>u/u Where nnnnn is ., 0 to 9 u/u is rate unit

KDS Model 410 Series Syringe Pumps

Operating Instructions (Continued)

RS232 COMMANDS (continued)

ratei nnnnn u/u

Sets infusion rate.

Where nnnnn is ., 0 to 9, and u/u are units.

Units required but if not specified then defaults to automatic setting based on syringe diameter.

ratw nnnnn u/u

Sets withdrawal rate.

voli nnnnn uu

Sets infusion target volume.

Where nnnnn is ., 0 to 9

uu are units μ l or ml

If units not specified then defaults to automatic setting.

volw nnnnn uu

Sets withdrawal target volume.

voli?

Queries volume setting.

Response: nnnnn<SP>uu

Where nnnnn is ., 0 to 9

uu are units μ l and ml

mode I

Sets mode to infusion.

mode w

Sets mode to withdrawal.

mode I/w

Sets mode to infusion / withdrawal.

mode w/I

Sets mode to withdrawal / infusion.

mode con

Sets mode to continuous.

Note: A dispense volume **must** be entered before selecting I/W, W/I and CON modes.

mode?

Query mode.

Response I, W, I/W, W/I, CON

dir rev

Changes direction of running pump. Available only in Infusion and Withdrawal modes.

dir?

Query direction.

Response I (infusion) or W (withdrawal).

Not applicable in infusion only models.

error?

Command returns values from 0 to 7 as listed below:

0 = no errors

1 = serial error

2 = stall

3 = stall + serial error

4 = serial overrun

5 = serial error + serial overrun

6 = stall + serial overrun

7 = stall + serial error + serial overrun

KDS Model 410 Series Syringe Pumps

Operating Instructions (Continued)

RS232 COMMANDS (continued)

error?	Errors 8 - 15 only occur if using pressure switch. 8 = overpressure 9 = serial error overpressure 10 = stall + overpressure 11 = stall + serial overrun + overpressure 12 = serial overrun + overpressure 13 = serial error + serial overrun + overpressure 14 = stall + serial overrun + overpressure 15 = stall + serial error + serial overrun + overpressure
---------------	--

Note: sending query also clears all errors.

A serial error indicates a command that is too long for the input buffer.

A serial overrun indicates that a command has been sent before the prior command has been processed.

A stall error indicated that a stall condition has occurred.

Essential that after each command you must wait for the prompt (indicating that the command has been executed) before sending the next command.

Also, the prompt will indicate that the command has been executed successfully, or not.

prom?	Queries software version response is number 2100.0xx or 2101.0xx or similar.
--------------	--

KDS Model 410 Series Syringe Pumps

Programmable Option– General Information

KEYPAD PROGRAMMABLE PUMPS

The "program mode " permits multistep dispenses without the need for computer control.

From the pump keypad, a custom program can be entered, which will control the pump from seconds to days; permit the flowrate to be changed for discrete time periods; repeat dispenses; control output TTL signals to coordinate with other laboratory instruments (or valves); or respond to inputs from other devices, such as switches or relays, and to perform loops, where dispense sequences are repeated.

The program is divided into time periods called STEPS, each of which can be up to 12 hours long. Each step is automatically numbered and, to simplify programming, a menu prompts the user to select the options available in each STEP.

The flowrate can be ramped up or down, or kept constant for a defined time period for a volume dispense. The initial and final flowrate for each period is entered and the pump automatically makes rate changes over the time period. No need to enter increments for a ramp up or down; the pump automatically ramps the rate linearly.

The pump can be paused and then restarted, either by a time delay or by a TTL input. Both TTL inputs and outputs can be controlled by the pump. The pump can therefore, respond to switch closures or send out signals to actuate valve, or other relays, switches etc.

Two separate loops can be programmed so that steps can be repeated. The number of repeat operations is controlled by the "loop count". For example, this is helpful when a volume dispense is required repeatedly, triggered by a switch.

The two loops can be "nested" so that the program can run for days and complex dispenses can be repeated many times.

KDS Model 410 Series Syringe Pumps

Programmable Option-Features

PARAMETERS WHICH CAN BE PROGRAMMED IN EACH STEP

Time duration

Infuse or withdraw

Start flowrate

End flowrate

TTL output settings

Pause, wait for TTL input actuation

Loops to repeat previous steps

To simplify the programming, previously programmed settings are stored in non-volatile memory and are displayed when **Program Mode** is selected. Whenever possible, options are displayed with the "active" option flashing. If flashing, this parameter can be selected or changed.

The pump can be programmed by first selecting **MODE** on the mainline menu and then selecting **Program** (PRGM).

DISPLAY AND PROGRAMMING SEQUENCE

After selecting Program Mode, display reads:

Table Dia Step Mode

DIA and TABLE

If the pump was previously used in Program Mode the pump will be initialized in Program Mode when it is switched on. For convenience, should a syringe change be required, it is possible to enter a new syringe size, either from the stored Table or DIA, without leaving the Program Mode.

If a syringe size change is made however, this will change all program values to defaults and will require reprogramming.

It is possible to review the syringe size in "Dia" or "Table" without changing the programmed settings.

In "Table" review the settings but select "QUIT", do not enter a diameter.

In "Dia" the settings will not change if there is no change to the diameter entered.

MODE

Mode selection reverts back to other pump operations.

STEP

Step selection starts the programming sequence.

KDS Model 410 Series Syringe Pumps

Programmable Option– Menu Operation

After selecting MODE and then PROGRAM the display will show STEP which leads into editing the program.

1) **Number of STEPS**

Menu prompts " NUM of Steps". Enter total number of program steps using numerical keypad and press SELECT or ENTER to save a maximum of 8.

2) **Edit STEP #**

The menu automatically increments the step number, however, it is possible to enter a different number.

If the step number displayed (flashing) is required then press SELECT to save and continue editing.

3) **Time**

Step # Time xx:xx:xx.

Time xx:xx:xx in hours, minutes and seconds.

Use the → key to move from left to right and enter the time using the numerical keypad. When the correct time is displayed press ENTER to load this time into memory.

4) **Infusion/ Withdraw**

The direction of travel for each step must be selected.

Initially, " Infusion " direction will be flashing. The direction keys, → and ← are used to switch between directions. SELECT key is then used to load the direction into memory.

5) **Rate**

The program requires the initial rate (Start), the ending rate (End), and the units.

a) Display reads: #Start: xxxxx uuu

is step number, automatically assigned.

xxxxx is the numerical flowrate.

Enter from the numerical keypad.

uuu are flowrate units.

Use the arrow key → to select units (displayed flashing)

Repeat to move through the unit options. Options are: $\mu\text{l}/\text{m}$ or $\mu\text{l}/\text{h}$, ml/m or ml/h

The ← key is used to move back to the numerical display.

Press ENTER to save.

The menu now prompts for the final rate which is entered in the same manner.

b) #End: xxxxx uuu

xxxxx numerical and uuu units of flowrate

KDS Model 410 Series Syringe Pumps

Programmable Option– Menu Operation (Continued)

8) **Loop (Continued)**

b) LOOP COUNT

After setting the initial step number of the loop, the menu will prompt for the "loop count", the number of times the loop will be repeated.

Maximum repeat number is 100.

Display reads: # Loop Count: x

The number of loops to be executed, x is entered from the numerical keypad followed by ENTER.

Note:

a) **Maximum number of loops is two.**

Once both loops are entered the loop option will NOT be displayed in menu.

b) **Changing Loops**

To change loops, if two are already entered, one loop must be cancelled before the new loop can be programmed.

c) **A LOOP within a LOOP**

It is possible to have a loop running within a loop.

9) **Saving the Step**

As there are many options in each step the program gives one more option, "Redo" to make changes before storing the Step.

menu prompts: # Step: Save Redo

The arrow keys are used to highlight the required option which can be saved with ENTER or SELECT.

10) **Program End**

After saving the step the program prompts: # Next Step Done

"Next Step" is selected, unless all steps are completed, and the above process is repeated for the number of steps required, up to 8. When all steps are programmed "Done" should be entered, with SELECT or ENTER to complete the programming.

The pump and display will now move to Step 1 ready to start the programmed dispense.

display reads: Stp 1 xx:xx:xx →

KDS Model 410 Series Syringe Pumps

Programmable Option– Running The Program

Run

The Run key starts the program; the displayed time counts down and the direction arrow flashes.

Hold/Continue

If the Run/Stop key is pressed while running a program, the pump is stopped but gives an option to end the program, or restart the pump and continue the program to its end.

Program changes when operating

Once a step has commenced no changes are possible in that step. However, while dispensing changes are permitted to steps still to be executed.

Syringe size changes

If the pump was previously used in Program Mode the pump will be initialized in Program Mode when it is switched on. For convenience, it is possible to enter a new syringe size, either from the stored Table or DIA, without leaving the Program Mode.

Note: If a syringe change is made this will change all program values to the default settings and will require reprogramming. A diameter change causes the pump to stop; resets the "number" of steps to 1; resets the "activestep" to 1; and all values will be set to the initial default settings. The initialization of the new settings takes approximately two seconds.

Stall Condition

The Fast Forward & Fast Reverse features do not work in Program Mode. Should a stall occur then go to Infusion Mode where the Fast Forward/Fast Reverse features works, and use these features to end the stall condition.

By going to the infusion mode the program is still saved in memory.

Changing programs containing loops

Only two loops are permitted in a program and it is necessary to remove from memory the previously used programs which contain loops. A convenient way to do this is to input a one step program which does not have a loop. This way, all loops are deleted from memory and the new program containing loops can be added.

KDS Model 410 Series Syringe Pumps

Programmable Option– RS232 Commands and Responses

All commands and responses in standard pumps remain the same, however, the program mode does have additional commands and responses.

Each pump can be controlled either from the keypad or via RS232 at all times, but the pump can only respond to one command at a time. When under RS232 control the display reads "REMOTE". All settings made via RS232 are stored in non-volatile memory.

To move the pump from Remote (RS232) to keypad control press **select**.

Changes to program parameters cannot be made when the pump is running therefore parameter setting commands, such as, step, travel, rate etc. are not applicable [NA] when the program is running.

When the pump is running all queries are disallowed except activestep?, timeleft?, and loops?

Commands are not case sensitive

After each command is received and executed the pump responds with prompt sequence:

a) Query commands:

carriage return (<CR>)|line feed, text, <CR>, line feed, 1 or 2 digit address, prompt character

b) Other commands:

<CR>, line feed, 1 or 2 digit address, prompt character

Prompts

>	running in infusion direction
<	withdrawing
:	stopped
NA	not applicable
E	error (see error? command)
P	pump is paused
carriage return <CR>	All pumps chain interpret this as a stop command
pump address, <CR>	Pump with the specified address responds with a prompt
pump address (optional), command, <CR>	Pump at the address executes the command and then responds with a prompt.

Note: If there are multiple pumps in the daisy chain and a pump address is not used then all pumps will respond to the non-specific command and return prompts. Multiple prompts results in a communications breakdown.

Note that withdrawal and continuous mode commands are recognised only by the infusion/withdrawal models.

KDS Model 410 Series Syringe Pumps

Programmable Option– RS232 Commands and Responses

(Continued)

mode prgm	sets pump in program mode. Response :
number n	sets number of steps in program. n = 1 - 8
step n	sets step number to be programmed. n = 1 - 8 important that step number be set before entering program settings
time xx:xx:xx	sets time duration of step to be programmed. hr:min:sec
travel i (w)	sets direction to infusion (withdrawal)
rateb nnnnn uu	sets step beginning rate where nnnnn is . , 0 to 9 where uu are units μlm , μlh , mlm , mlh . Note: if set rate is out of range then response is NA; rate is set a zero
ratef nnnnn uu	sets step finish rate where nnnnn is . , 0 to 9 where uu are units μlm , μlh , mlm , mlh . Note: if set rate is out of range then response is NA; rate is set a zero
portout p	sets status of output pins 1 and 6 where p is HH (1=high, 6=high) HL (1=high, 6=low) LH (1=low, 6=high) LL (1=low, 6=low)
pause y or n	sets status of pause y = active n = inactive
loop y or n	sets loop status y = yes n = no
loopto n	set step number to loop to where n = 1 to 8
loopcnt b	sets number of loops to be repeated where b = 1 to 100
save	saves step settings important that each step is saved
done	saves all programmed steps important that "done" is entered after all steps saved
wait	stops pump (pauses), but can be restarted
continue	restarts pump after "wait" command, program continues
nextstep	causes program to jump to the next step
mode?	query mode. Response PGM
activestep?	queries step running response: n where n = 1 to 8

KDS Model 410 Series Syringe Pumps

Programmable Option– RS232 Commands and Responses

(Continued)

PROGRAM EXAMPLE

Syringe selected, 4.70 mm diameter

RS232 programming

mode prgm	Select Program mode
Number 4	Sets number of steps in the program
Step 1	Selects Step 1 for programming
time 00:00:10	Step 1 time duration is 10 seconds
travel I	Infusion selected
rateb 0 mlm	Step 1 beginning rate is 0 ml/minute
ratef 1 mlm	Step 1 finishing rate is 1 ml/minute
portout hh	Output pins 1 and 6 set at high/high
pause n	Pause inactive
loop n	No loops
save	Save step settings
Step 2	Ready to program step 2
time 00:00:15	Set time duration to 15 seconds
rateb 1 mlm	Assumes previous travel direction (infusion), and sets step 2 beginning rate 1 ml/minute.
ratef 0.1 mlm	Finishing rate 0.1 ml/minute
loop y	Select a loop
loopto 1	Program will loop back to step 1 after completeing step 2
loopcnt 1	Will repeat the loop one time
save	
step 3	Ready to program step 3
time 00:00:20	Time of step 3 is 20 seconds
rateb .3 mlm	Sets begin rate to 0.3 ml/min. Assumes no direction change.
ratef 0 mlm	Sets finish rate to 0 ml/min.
save	
Step 4	Program step 4
time 00:00:12	Time duration 12 seconds
travel w	Change direction to withdrawal
rateb 1 mlm	Withdraw rate set to 1.0 ml/minute.
ratef 1 mlm	Finish rate 1 ml/min.
loop y	Select a loop
loopto 3	After step 4 will loop back to and repeat step 3.
loopcnt 1	Will repeat loop one time.
save	
done	completes and saves program

Queries: a) loops? S2:1 S4:1 loop in step 2, loop count is 1; loop in step 4, count 1

b) step 3 portout? HH Portout set in step 1 and remained unchanged
 c) step 1 ratef? 1 ml/m Finish rate in step 1 is 1.0 ml/minute

KDS Model 410 Series Syringe Pumps

RS232 COMMANDS

RS232 Format

- 8 data bits
- No parity
- 1 stop (can use 2 stops)

Pump uses simple three wire communications - ground, transmit, and receive
No flow control. No handshaking.

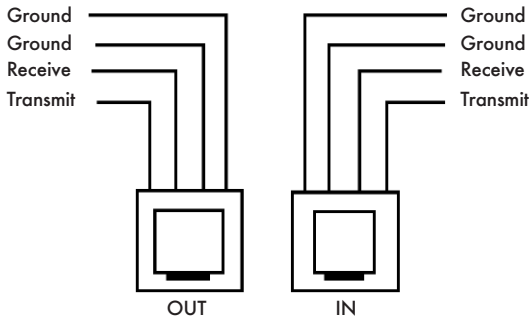

PC with 9-pin connector

- data IN pin 2
- data OUT pin 3
- ground pin 5

PC with 25-pin connector

- data OUT pin 2
- data IN pin 3
- ground pin 7

KDS Model 410 Series Syringe Pumps

TTL Specifications

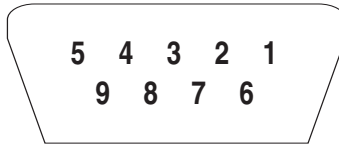

As viewed from rear of the pump.

Pin

3	Vss , ground ref.	
1,6	Controllable output with Programmable models could be used for relay or valve control (low - infusing, high - refilling)	
8	Trigger	Falling edge starts /stops pump eg. Footswitch
4	Gate	Change from high to low - starts when running stays low, change to high - stops eg. footswitch, timer
2	Directional Output	high - infuse, low - refill (stays high when stopped)
5	Undefined Input or Output	
7	Run Indicator	high - running, low - stopped
9	Reverse Direction	Normally high; connect to ground (pin 3) reverses. Direction (only applies to infuse/ withdraw mode)

logic low 0 - 0.5V, max 2ma current sink

logic high 2V - 5V

Fuses

The fuses are located, in the power entry module on the rear panel. The linecord must be removed first to gain access to the fuse holder.

Fuse

5x20mm, 250V
0.25AT slow blow

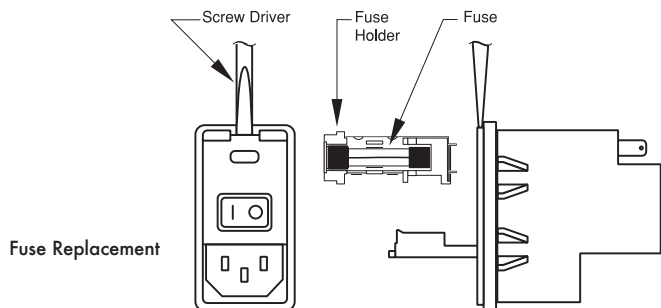

KDS Model 410 Series Syringe Pumps

Maintenance

Maintenance is required only for the moving mechanical parts, which should be kept clean and lubricated. Occasionally, a small amount of light machine oil should be applied to the guide rods and a small amount of grease or oil to the leadscrew.

Solvents of any type should never be used to clean the pump. A mild detergent solution may be used to clean the keypad.

KDS Model 410 Series Syringe Pumps

(1) "Air-Tite" All Plastic

1 cc	4.70 mm
2.5	9.70
5.0	12.48
10	15.89
20	20.00
30	22.50
50	28.90

(2) Becton Dickinson

Interim, WW design, Plastipak

1 cc	4.70 mm
3	8.59
5	11.99
10	14.48
20	19.05
30	21.59
60	26.60

(3) Becton Dickson

Glass - all types

0.5 cc	4.64 mm
1	4.64
2.5	8.66
5	11.86
10	14.34
20	19.13
30	22.70
60	28.60

(4) Hamilton

1000-Series Gastight

10 µl	0.46 mm
25	0.73
50	1.03
100	1.46
250	2.30
500	3.26
1ml	4.61
2.5	7.28
5	10.30
10	14.57
25	23.03
50	32.57

(5) Popper & Sons, Inc.

Perfektum Glass

0.25 cc	3.45 mm
0.5	3.45
1	4.50
2	8.92
3	8.99
5	11.70
10	14.70
20	19.58
30	22.70
50	29.00

(6) Ranfac

2 cc	9.12 mm
5	12.34
10	14.55
20	19.86
30	23.20
50	27.60

(7) Scientific Glass Engineering

SGE	
25 µl	0.73 mm
50	1.03
100	1.46
250	2.30
500	3.26
1ml	4.61
2.5	7.28
5	10.30
10	14.57

(8) Sherwood - Monojet Plastic

1 cc	4.65 mm
3	8.94
6	12.70
12	15.90
20	20.40
35	23.80
50	26.60
140	38.40

(9) Terumo

1 cc	4.73 mm
3	9.00
5	13.04
10	15.79
20	20.18
30	23.36
60	29.45

(10) Unimetrics

Series 9000

10µl	0.46 mm
25	0.73
50	1.03
100	1.46
250	2.30
500	3.26
1000	4.61

(11) Stainless Steel

KD Scientific

2.5ml	4.790 mm
8	9.53
20	19.13
50	28.60
100	34.90
200	44.755

(12) Nikepal

1ml	4.80 mm
2	6.45
5	12.60
10	15.15
20	20.40
30	22.90
50	27.45
100	35.90
150	34.20

KDS Model 410 Series Syringe Pumps

Japanese Table of Syringe Diameters (Available in Japanese Models)

(1) "Air-Tite" All Plastic

1cc	4.70 mm
2.5	9.70
5.0	12.48
10	15.89
20	20.00
30	22.50
50	28.90

(2) Becton Dickinson

Interim, WW design, Plastipak

1cc	4.70 mm
3	8.59
5	11.99
10	14.48
20	19.05
30	21.59
60	26.60

(3) Becton Dickson

Glass - all types

0.5 cc	4.64 mm
1	4.64
2.5	8.66
5	11.86
10	14.34
20	19.13
30	22.70
60	28.60

(4) Hamilton

1000-Series Gastight	
10 µl	0.46 mm
25	0.73
50	1.03
100	1.46
250	2.30
500	3.26
1ml	4.61
2.5	7.28
5	10.30
10	14.57
25	23.03
50	32.57

(5) JMC Air-Tite pls

1ml	4.66 mm
2	6.90
2.5	9.10
5	12.62
10	14.34
20	19.68
30	22.44
50	28.80
100	36.68

(6) Nippro

1ml short	6.61 mm
1ml long	4.75
3	9.53
5	12.96
10	15.78
20	20.07
30	23.17
50	29.13

(7) Hoshi

1ml sm	4.80 mm
1ml lg	6.70
2 mm sm	6.70
2 ml lg	9.20
3	10.30
5	12.20
10	15.00
20	19.00
30	22.50
50	25.50
100	34.00

(8) Natsume

0.25 ml	2.60 mm
0.50	3.20
1	4.30
2	6.30
3	7.30
5	9.50

(9) Top

1ml	4.70 mm
2	6.40
3	9.30
6	13.10
12	15.40
25	21.00
30	23.00
50	29.00

(10) Terumo

1ml	4.73 mm
3	9.00
5	13.04
10	15.79
20	20.18
30	23.36
60	29.45

(11) Terumo Japan

1ml sm	4.73 mm
1ml lg	6.50
3	8.95
5	13.00
10	15.80
20	20.15
30	23.10
50	29.10

(12) Stainless Steel

KD Scientific	
2.5 ml	4.790 mm
8	9.53
20	19.13
50	28.60
100	34.90
200	44.755

(13) Nikepal

1ml	4.80 mm
2	6.45
5	12.60
10	15.15
20	20.40
30	22.90
50	27.45
100	35.90
150	34.20

KDS Model 410 Series Syringe Pumps

Standard Minimum and Maximum Flow Rates

Syringe size	Diameter*	Minimum	Maximum
10 µl	0.46 mm	0.001 µl/hr	21.10 µl/min
25 µl	0.73 mm	0.003 µl/hr	53.15 µl/min
50 µl	1.03 mm	0.005 µl/hr	105.8 µl/min
100 µl	1.46 mm	0.009 µl/hr	212.6 µl/min
250 µl	2.3 mm	0.021 µl/hr	527.6 µl/min
500 µl	3.26 mm	0.042 µl/hr	1060 µl/min
1 ml	4.61 mm	0.083 µl/hr	2119 µl/min
2.5 ml	7.28 mm	0.207 µl/hr	5286 µl/min
3 ml	8.59 mm	0.288 µl/hr	7360 µl/min
5 ml	10.3 mm	0.414 µl/hr	634 ml/hr
10 ml	14.57 mm	0.828 µl/hr	1270 ml/hr
20 ml	19.05 mm	1.414 µl/hr	2171 ml/hr
30 ml	21.59 mm	1.817 µl/hr	2789 ml/hr
50 ml	28.9 mm	3.277 µl/hr	4998 ml/hr
60 ml	26.6 mm	2.757 µl/hr	4234 ml/hr
100 ml	34.9 mm	4.746 µl/hr	7289 ml/hr
140 ml	38.4 mm	5.746 µl/hr	8824 ml/hr

Syringes from different manufacturers can have slightly different limits.

Note: *This is a reference diameter used to calculate the flow rate. The specific diameter should be entered for your syringe type.

KDS Model 410 Series Syringe Pumps

Japanese Minimum and Maximum Flow Rates (Available in Japanese Models)

Syringe size	Diameter*	Minimum	Maximum
10 µl	0.46 mm	0.001 µl/hr	21.10 µl/min
25 µl	0.73 mm	0.003 µl/hr	53.15 µl/min
50 µl	1.03 mm	0.005 µl/hr	105.8 µl/min
100 µl	1.46 mm	0.009 µl/hr	212.6 µl/min
250 µl	2.3 mm	0.021 µl/hr	527.6 µl/min
500 µl	3.26 mm	0.042 µl/hr	1060 µl/min
1 ml	4.7 mm	0.087 µl/hr	2703 µl/min
2.5 ml	9.1 mm	0.323 µl/hr	6259 µl/min
3 ml	9.3 mm	0.337 µl/hr	8626 µl/min
5 ml	12.62 mm	0.7 µl/hr	953 ml/hr
10 ml	14.34 mm	0.802 µl/hr	1230 ml/hr
20 ml	19.68 mm	1.51 µl/hr	2317 ml/hr
30 ml	22.44 mm	1.963 µl/hr	3013 ml/hr
50 ml	28.8 mm	3.232 µl/hr	4963 ml/hr
60 ml	36.68 mm	5.243 µl/hr	8051 ml/hr

Syringes from different manufacturers can have slightly different limits.

Note: *This is a reference diameter used to calculate the flow rate. The specific diameter should be entered for your syringe type.

KDS Model 410 Series Syringe Pumps

Limited Warranty

KD Scientific Inc. warrants to the first consumer purchaser, for a period of one year from the date of purchase that this unit, when shipped in its original container, will be free from defective workmanship and materials and agree that it will, at its option, either repair or replace the defective unit.

This warranty does not extend to misuse, neglect or abuse, normal wear and tear, accident, modification or unauthorised repair.

KD Scientific will not be liable or in any way responsible for any incidental or consequential economic or property damage. Some States do not allow the exclusion of incidental or consequential damages, so the above exclusion may not apply to you.

There are no implied warranties of merchantability, or fitness for a particular use, or of any other nature. Some states do not allow this limitation on implied warranty, so the above limitation may not apply to you.

If a defect arises within the warranty period contact KD Scientific Inc., (see address below).

The customer is responsible for shipping charges and must first obtain a Return Material Authorization number (RMA) before the unit will be accepted. If a replacement unit is issued it is covered only for the remainder of the original warranty period dating from the purchase of the original device.

This warranty gives you specific legal rights. You may also have other rights which vary from state to state.

Note: This pump is not registered with the FDA and is not for clinical use on human subjects.

Syringe pumps are manufactured by:

KD Scientific, Inc.

84 October Hill Road

Holliston, MA 01746

Phone: 508.429.6809 Fax: 508.893.0160

E-mail: info@kdsscientific.com

Web: www.kdsscientific.com

The logo for KD Scientific, featuring the lowercase letters 'kd' in a bold, blue, sans-serif font, followed by the word 'Scientific' in a larger, blue, serif font. A horizontal line is positioned below the 'kd' portion of the logo.

Copyright © 2005 by KD Scientific, Inc. All rights reserved. Printed in USA

WEEE/RoHS Compliance Statement

EU Directives WEEE and RoHS

To Our Valued Customers:

We are committed to being a good corporate citizen. As part of that commitment, we strive to maintain an environmentally conscious manufacturing operation. The European Union (EU) has enacted two Directives, the first on product recycling (Waste Electrical and Electronic Equipment, WEEE) and the second limiting the use of certain substances (Restriction on the use of Hazardous Substances, RoHS). Over time, these Directives will be implemented in the national laws of each EU Member State.

Once the final national regulations have been put into place, recycling will be offered for our products which are within the scope of the WEEE Directive. Products falling under the scope of the WEEE Directive available for sale after August 13, 2005 will be identified with a "wheelie bin" symbol.

Two Categories of products covered by the WEEE Directive are currently exempt from the RoHS Directive - Category 8, medical devices (with the exception of implanted or infected products) and Category 9, monitoring and control instruments. Most of our products fall into either Category 8 or 9 and are currently exempt from the RoHS Directive. We will continue to monitor the application of the RoHS Directive to its products and will comply with any changes as they apply.

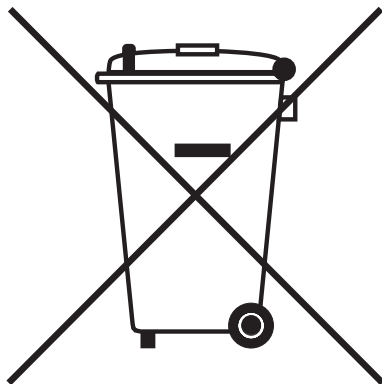

- **Do Not Dispose Product with Municipal Waste.**
- **Special Collection/Disposal Required.**