



A Scheu Company

## OPERATING INSTRUCTIONS AND OWNER'S MANUAL

Model # 125-R / 125-RN

**READ INSTRUCTIONS CAREFULLY:** Read and follow all instructions. Place instructions in a safe place for future reference. Do not allow anyone who has not read these instructions to assemble, light, adjust or operate the heater.

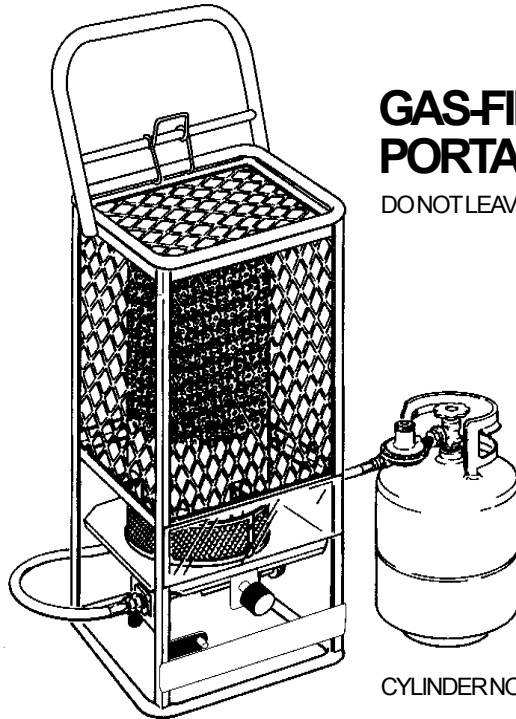

### GAS-FIRED INFRA-RED PORTABLE CONSTRUCTION HEATER

DO NOT LEAVE HEATER UNATTENDED OR IN OPERATION WHILE SLEEPING

CYLINDER NOT INCLUDED



#### GENERAL HAZARD WARNING:

FAILURE TO COMPLY WITH THE PRECAUTIONS AND INSTRUCTIONS PROVIDED WITH THIS HEATER CAN RESULT IN DEATH, SERIOUS BODILY INJURY AND PROPERTY LOSS OR DAMAGE FROM HAZARDS OF FIRE, EXPLOSION, BURN, ASPHYXIATION, CARBON MONOXIDE POISONING, AND/OR ELECTRICAL SHOCK.

ONLY PERSONS WHO CAN UNDERSTAND AND FOLLOW THE INSTRUCTIONS SHOULD USE OR SERVICE THIS HEATER.

IF YOU NEED ASSISTANCE OR HEATER INFORMATION SUCH AS INSTRUCTION MANUALS, LABELS, ETC., CONTACT THE MANUFACTURER.



#### WARNING:

FIRE, BURN, INHALATION AND EXPLOSION HAZARD. KEEP SOLID COMBUSTIBLES SUCH AS BUILDING MATERIALS, PAPER OR CARDBOARD A SAFE DISTANCE AWAY FROM THE HEATER AS RECOMMENDED BY THE INSTRUCTIONS. NEVER USE THE HEATER IN SPACES WHICH DO OR MAY CONTAIN VOLATILE OR AIRBORNE COMBUSTIBLES OR PRODUCTS SUCH AS GASOLINE, SOLVENTS, PAINT THINNER, DUST PARTICLES OR UNKNOWN CHEMICALS.



**WARNING:** NOT FOR HOME OR RECREATIONAL VEHICLE USE

## SPECIFICATIONS

MODEL NO.....125-R.....125RN  
 GAS TYPE ..... LP-Gas ..... Natural Gas  
 MAX. INLET PRESSURE.... 14 IN. W.C. .... 14 IN. W.C.  
 MIN. INLET PRESSURE .. 13.5 IN. W.C. .... 7 IN. W.C.  
 MANIFOLD PRESSURE .. 12.5 IN. W.C. .... 6 IN. W.C.



**WARNING**  
 DO NOT EXCEED ½ psi (14" w.c.) GAS PRESSURE TO THE GAS CONTROL VALVE.

## VENTILATION



**WARNING**  
 THIS APPLIANCE IS UNVENTED AND MUST BE USED ONLY IN A WELL VENTILATED AREA.

The flow of combustion and ventilation air must not be obstructed. DO NOT use in a tightly enclosed area.

Any combustion process requires and consumes oxygen, and may produce carbon monoxide. This heater must be operated with adequate ventilation. Two openings directly to the outdoors must be provided, one low and one high, preferably on opposite sides of the area to be heated. Each of these openings must provide at least three square inches of combustion air-intake area and exhaust outlet area for every 1000 BTUs per hour of heater input rate in order to complete the combustion/ventilation process. Provide additional ventilation for any additional fuel-burning appliances and/or additional occupants.

## CLEARANCE (Minimum clearances to combustibles)

Do not exceed the gas supply pressures shown on rating plates. The maximum inlet gas supply pressures and minimum inlet supply pressures (for purposes of input adjustment) for LP-Gas and Natural gas are shown as follows:

MODEL NO.	BTU/HR RATING TYPE GAS		NORMAL OPERATING POSITION	CLEARANCE TO COMBUSTIBLES		
	NATURAL	LP-GAS		TOP	SIDES	BACK
125-R		125,000*	VERTICAL	48"	60"	60"
125RN	125,000		VERTICAL	48"	60"	60"

\*Tank size and tank temperature can directly affect BTU output

## CONTENTS

Installation Instructions ..... 3  
 Location ..... 3  
 Piping ..... 3  
 Odor Fading Warning..... 4  
 Operating Instructions ..... 5  
 Lighting and Shut Down ..... 5  
 Maintenance Instructions ..... 6  
 Replacement Parts List ..... 7  
 Service and Parts Ordering Information ..... 9



**FOR YOUR SAFETY**  
 Do not use this heater in a space where gasoline or other liquids having flammable vapors are stored or used.

The heater is designed and approved for use as a construction heater under ANSI Z83.7 / CGA 2.14 - 2000

We cannot anticipate every use which may be made of our heaters. CHECK WITH YOUR LOCAL FIRE SAFETY AUTHORITY IF YOU HAVE QUESTIONS ABOUT APPLICATIONS.

Other standards govern the use of fuel gases and heat producing products in specific applications. Your local authority can advise you about these.

This appliance is intended to be used primarily for the heating of buildings under construction, alteration or repair.



THE STATE OF CALIFORNIA REQUIRES THE FOLLOWING WARNING:  
**WARNING**  
 Combustion by-products produced when using this product contain carbon monoxide, a chemical known to the State of California to cause cancer and birth defects (or other reproductive harm).

# INSTALLATION INSTRUCTIONS

## GENERAL:

**READ THESE INSTRUCTIONS CAREFULLY.** Read and adhere to these instructions. **DO NOT** allow anyone who has not read these instructions to assemble, light, adjust or operate this heater.

**DO NOT attempt to operate the heater with any gas other than that indicated on the heater nameplate.**

For the U.S. and/or Canada, the installation of this appliance must comply with local and/or Provincial codes or, in the absence of these codes,

- With the (U.S.) National Fuel Gas Code, ANSI Z223.1 – Latest Edition (for Natural and LP-Gas operation, Models 125-RN, 125-R), and with the (U.S) Standard for the Storage and Handling of Liquefied Petroleum Gases, ANSI/NFPA 58 (for LP Gas operation, Model 125-R), or
- with the current (Canadian) CAN/CGA B149.1 AND B149.2 INSTALLATION CODES.

This heater (including hose and regulator assembly if applicable) must be inspected before each use and at least annually by a qualified service person. If the hose for Model 125-R shows evidence of excessive abrasion or wear, or if the hose is cut, it must be replaced prior to the heater being put into operation. The replacement hose assembly shall be that specified by the manufacturer. See the parts list.

## LOCATION

The heater (and LP-Gas supply cylinder if applicable) must be located on a hard, flat, level surface to minimize the risk of accidental tipping. If an LP Gas supply cylinder is used (i.e. with Model 125-R), the cylinder should be adequately restrained to prevent accidental tipping. **DO NOT operate this heater with the supply cylinder in any other than the upright position.**

This appliance must be installed only in locations where the potential for physical damage to the appliance (i.e., due to physical contact) is reduced to a minimum.

The installer must inform the owner/operator of this appliance that precautions must be taken to protect the appliance from physical damage.

This appliance produces radiant heat. Therefore, it must be located at least six feet away from any LP-Gas container and must not be directed toward any LP-Gas container within 20 feet.

Due to high surface and exhaust temperatures, adults and children must observe clearances to avoid burns or clothing ignition.

The heater must be installed in a location such that it will not be exposed directly to water spray, rain, and/or dripping water.

Use of this heater in a draft/windy area decreases its efficiency. If possible, operate the unit in a draft free area.

## PIPING

### For Model 125-R (for use with LP-Gas)

This model may be connected to a self-contained LP-Gas supply system using the hose and regulator assembly supplied with the appliance, OR, it may be connected to a permanently installed LP-Gas supply system.

If connected to a self-contained LP-Gas supply system, the hose assembly must be inspected prior to each use of the heater. If it is evident that there is excessive abrasion or wear, or if the hose is cut, it must be replaced prior to the heater being put into operation.

If connected to a self-contained LP-Gas supply system, the cylinder must have no less than a minimum capacity of 20 pounds and no more than a maximum capacity of 100 pounds of LP-Gas. **DO NOT** connect this appliance to a cylinder having less than a nominal 20 pounds capacity of LP-Gas. **DO NOT** connect this appliance to more than one (1) 100 pound cylinder.



### WARNING

**NEVER USE A FORK LIFT TRUCK TYPE CYLINDER.**

The connection of Model 125-R to an LP-Gas cylinder must be made in a well ventilated area using the regulator and hose assembly supplied with the appliance. **DO NOT attempt to adjust this regulator.** It has been preset at the factory to provide safe and proper operation of the appliance. Use a 7/8" open end wrench to connect the POL fitting (supplied with the LP regulator) to the LP-Gas cylinder. Turn the POL nut in a counter-clockwise direction (left hand thread) until tight. **DO NOT use pipe compound on POL threads.**

The heater must be located at least six feet away from any LP-Gas cylinder and must not be directed toward any LP-Gas cylinder within 20 feet. If more than one heater is used, they and the supply cylinders must be separated by at least 20 feet.

The gas supply must be turned off at the LP-Gas supply cylinder when the heater is not in use.

When the heater is to be stored indoors, the connection between the LP-Gas supply cylinder and the heater must be disconnected and the cylinder removed from the heater and stored in accordance with Chapter 5 of the Standard for the Storage and Handling of Liquefied Petroleum Gases. ANSI/NFPA 58 (U.S.) OR CAN/CGA B149.2 (Canada).

If connected to a permanently installed LP-Gas supply system, the system requires the use of a two-stage gas regulator assembly which is normally provided by your LP Gas dealer as part of the LP-Gas supply system. Consult with your local LP Gas dealer for details concerning proper equipment and installation.

## ODOR FADE WARNING



### **WARNING** **Asphyxiation Hazard**

- Do not use this heater for heating human living quarters.
- Do not use in unventilated areas.
- The flow of combustion and ventilation air must not be obstructed.
- Proper ventilation air must be provided to support the combustion air requirements of the heater being used.
- Refer to the specification section of the heater's manual,

heater dataplate, or contact the *Scheu Products Company* to determine combustion air ventilation requirements of the heater.

- Lack of proper ventilation air will lead to improper combustion.
- Improper combustion can lead to carbon monoxide poisoning leading to serious injury or death. Symptom of carbon monoxide poisoning can include headaches, dizziness and difficulty in breathing.

### **FUEL GAS ODOR**

**LP gas and natural gas have man-made odorants added specifically for detection of fuel gas leaks.**

**If a gas leak occurs you should be able to smell the fuel gas. Since Propane (LP) is heavier than air you should smell for the gas odor low to the floor. ANY GAS ODOR IS YOUR SIGNAL TO GO INTO IMMEDIATE ACTION!**

- Do not take any action that could ignite the fuel gas. Do not operate any electrical switches. Do not pull any power supply or extension cords. Do not light matches or any other source of flame. Do not use your telephone.
- Get everyone out of the building and away from the area immediately.
- Close all propane (LP) gas tank or cylinder fuel supply valves, or the main fuel supply valve located at the meter if you use natural gas.
- Propane (LP) gas is heavier than air and may settle in low

areas. When you have reason to suspect a propane leak, keep out of all low areas.

- Use your neighbor's phone and call your fuel gas supplier and your fire department. Do not re-enter the building or area.
- Stay out of the building and away from the area until declared safe by the firefighters and your fuel gas supplier.
- FINALLY, let the fuel gas service person and the firefighters check for escaped gas. Have them air out the building and area before you return. Properly trained service people must repair any leaks, check for further leakages, and then relight the appliance for you.

### **ODOR FADING - NO ODOR DETECTED**

- Some people cannot smell well. Some people cannot smell the odor of the man-made chemical added to propane (LP) or natural gas. You must determine if you can smell the odorant in these fuel gases.
- Learn to recognize the odor of propane (LP) gas and natural gas. Local propane (LP) gas dealers will be more than happy to give you a scratch and sniff pamphlet. Use it to become familiar with the fuel gas odor.
- Smoking can decrease your ability to smell. Being around an odor for a period of time can affect your sensitivity to that particular odor. Odors present in animal confinement buildings can mask fuel gas odor.

- **The odorant in propane (LP) gas and natural gas is colorless and the intensity of its odor can fade under some circumstances.**

- If there is an underground leak, the movement of gas through the soil can filter the odorant.
- Propane (LP) gas odor may differ in intensity at different levels. Since Propane (LP) gas is heavier than air, there may be more odor at lower levels.
- **Always be sensitive to the slightest gas odor.** If you continue to detect any gas odor, no matter how small, treat it as a serious leak. Immediately go into action as discussed previously.

### **ATTENTION - CRITICAL POINTS TO REMEMBER!**

- Propane (LP) gas has a distinctive odor. Learn to recognize these odors. (Reference Fuel Gas Odor and Odor Fading sections above).
- Even If you are not properly trained in the service and repair of the heater, ALWAYS be consciously aware of the odors of propane (LP) gas and natural gas.
- If you have not been properly trained in repair and service of propane (LP) gas then do not attempt to light heater, perform service or repairs, or make any adjustments to the heater on the propane (LP) gas fuel system.

- A periodic sniff test around the heater or at the heater's joints; i.e. hose, connections, etc., is a good safety practice under any conditions. If you smell even a small amount of gas, CONTACT YOUR FUEL GAS SUPPLIER IMMEDIATELY. DO NOT WAIT!

## For Model 125-RN (for use with natural gas)

Piping must be clean and free from scale or burrs.

Install regulator supplied with heater. Connect with 1/2" NPT nipple (not included) to Control Valve.

Connect the appliance to an appropriately designed and installed fuel supply system. This system must include an approved manual shut-off valve which is readily accessible and is located within six (6) feet of the appliance.

Additionally, a sediment trap or drip leg must be located upstream of this manual shut-off valve. Refer to the appropriate (natural gas) installation code noted above. If a flexible connector is used, it must be of an approved type.

Before attempting to ignite the appliance, all gas fittings and connections must be thoroughly checked for gas leaks. Apply a small amount of a mild soap and water solution to all fittings and connections and observe for escaping bubbles. If any leaks are detected, shut off the gas supply to the appliance immediately. Wait a minimum of five minutes, repair the leak(s) and retest for leakage. Dry all fittings and connections after leak testing.



### WARNING

NEVER USE A FLAME FOR GAS LEAK TESTING.

## OPERATING INSTRUCTIONS



### WARNING

IF YOU DO NOT FOLLOW THESE INSTRUCTIONS EXACTLY, A FIRE OR EXPLOSION MAY RESULT CAUSING PROPERTY DAMAGE, PERSONAL INJURY, OR LOSS OF LIFE.



### CAUTION

THIS APPLIANCE IS HOT DURING NORMAL OPERATION, AVOID PHYSICAL CONTACT.



### CAUTION

DO NOT PLACE CLOTHING OR OTHER COMBUSTIBLE MATERIALS ON THIS APPLIANCE. DO NOT MOVE OR HANDLE HEATER DURING OPERATION OR UNTIL COMPLETELY COOL.

**DO NOT operate this heater if any part has been under water.** Call a qualified service technician to inspect the appliance and to replace any part of the control system or gas control valve which has been under water.

This appliance must be installed and operated only in locations where the potential for physical damage to the appliance is reduced to a minimum. The owner/operator of this appliance must ensure that precautions are taken to protect the appliance from physical damage.

## LIGHTING AND SHUT DOWN

### Lighting the Heater

- 1 Before attempting to light the heater, smell all around the heater area for gas. Be sure to smell next to the floor because LP Gas is heavier than air and will settle on the floor. Turn on the gas supply to the appliance and check all fittings and connections for gas leaks using a mild soap and water solution. Read enclosed Odor Fade and Propane Sheet for additional information about detecting propane leaks. **NEVER use a match to check for gas leaks.** Should a gas leak occur, shut off the gas supply to the appliance immediately. Wait a minimum of five minutes before repairing the leak.
- 2 Use only the fuel intended for this appliance. Check the appliance rating plate for the correct fuel information.
- 3 Turn the gas valve knob clockwise to the "OFF" position. See Fig. 1 and Fig. 2 for location of appliance parts.
- 4 Wait a sufficient length of time (at least five minutes) to allow gas which may have accumulated in burner compartment to escape.
- 5 Turn on the main gas supply.
- 6 Turn the gas valve knob counter-clockwise to the "PILOT" position (see Fig. 1).
- 7a Depress and turn Control Knob counterclockwise to "Pilot" position and hold for 1-2 minutes. This may take longer to purge air from the supply hose depending on the length of the hose being used.  
  
Depress red spark ignition button to light pilot flame (repeat until pilot lights) and continue to hold Control Knob at "Pilot" position for 30-60 seconds to enable Pilot Light Safety System.  
  
Fully turn Control Knob to "Hi" position to light burner. **or...**
- 7b To light the pilot, move the lighting hole cover aside (see Fig. 1) and place a lighted match into the hole. Depress the gas valve knob and hold while lighting and observing the pilot burner. Ensure that the pilot burner ignites from the match. Allow the pilot to burn approximately 30 seconds before releasing the gas

valve knob. If pilot does not remain lighted, repeat the lighting operation allowing a longer period of time before releasing the gas valve knob.

NOTE: In cases where long runs of gas supply lines have been installed ahead of the appliance, it may be necessary to bleed trapped air out of the supply lines before lighting the pilot. New installations generally require bleed of supply lines. Wait a minimum of five minutes after bleeding the supply lines before attempting to light the heater.

Adjust pilot if necessary as noted under "Pilot Burner Adjustment."

8. Turn the gas valve knob counter-clockwise to the "ON" position (see Fig. 1). The burner will light. **DO NOT operate the heater in any other than the full "ON" position.**
9. **IMPORTANT: DO NOT attempt to adjust the main burner input using the main gas supply valve**, for this may cause the pilot and thermocouple to shut down the burner (Fig. 2).

### Shut-down instructions:

To turn the heater OFF,

- For short periods of time, turn the main burner off by rotating the gas valve knob clockwise to the "PILOT" position.
- For extended periods of non use, turn the appliance completely off by rotating the gas valve knob clockwise to the "PILOT" position, depress the knob slightly, then rotate the knob fully clockwise to the "OFF" position. (Note: For Model 125-R, also turn off the gas supply cylinder.)

### Pilot burner adjustment:

1. Remove the pilot adjustment cap. The pilot adjustment cap is a slotted screw located in front of the "Pilot" designation stamped on top of valve body just below the gas valve knob.
2. Adjust the pilot key to provide properly sized flame. Rotate the key "clockwise" to decrease or "counter-clockwise" to increase flame.
3. Replace the pilot adjustment cap.

## MAINTENANCE INSTRUCTIONS

This heater (including hose and regulator assembly if applicable) must be inspected before each use. If the hose for the Model 125-R shows evidence of excessive abrasion or wear, or if the hose is cut, it must be replaced prior to the

heater being put into operation. The replacement hose assembly shall be that specified by the manufacturer. See the parts list.

The appliance area must be kept free and clear of combustible materials, gasoline and other flammable vapors and liquids at all times.

The flow of combustion and ventilation air must not be obstructed.

### Cleaning the heater:

Periodically, the heater must be cleaned of all dirt and dust particles.

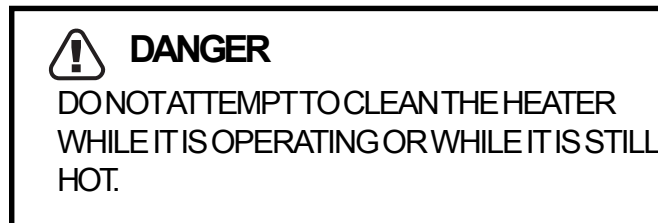

Turn the heater off and wait until it has completely cooled (at least 20 minutes) before cleaning.

Clean the outside of the heater using a damp cloth. DO NOT clean the heater by spraying water on it. Wipe the outside of the heater off with a dry cloth after cleaning.

Clean the inside of the heater using compressed air. Blow air back and forth along all inside surfaces until all dust has been dislodged.

Clean the orifice of each burner with a #69 drill bit (for LP-Gas). Clean the orifice manually (by hand) – DO NOT use power drill.

Clean the thermocouple lead.

**DO NOT operate this heater if any part has been under water.** Call a qualified service person to inspect the appliance and to replace any part of the control system or gas control valve which has been under water.

This heater must be inspected at least annually by a qualified service person.

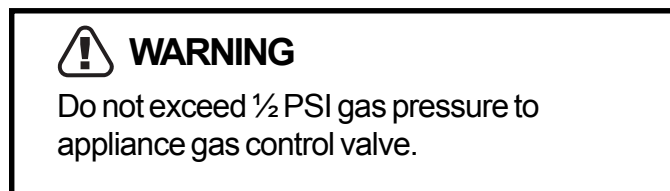

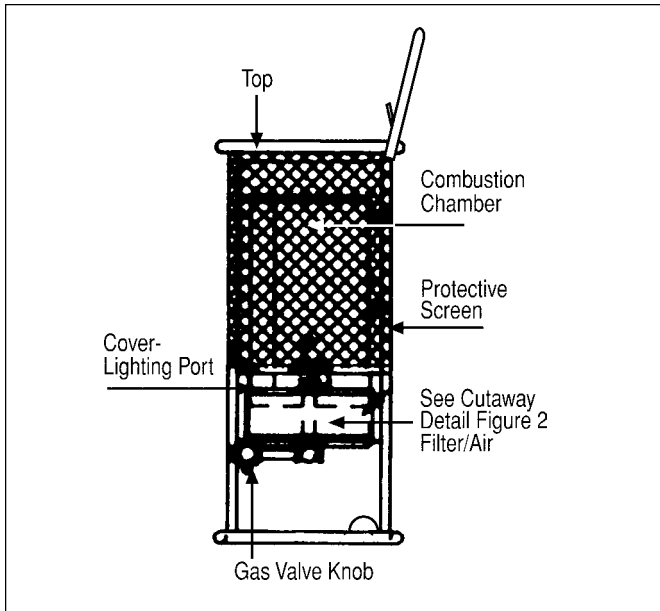

Figure 1

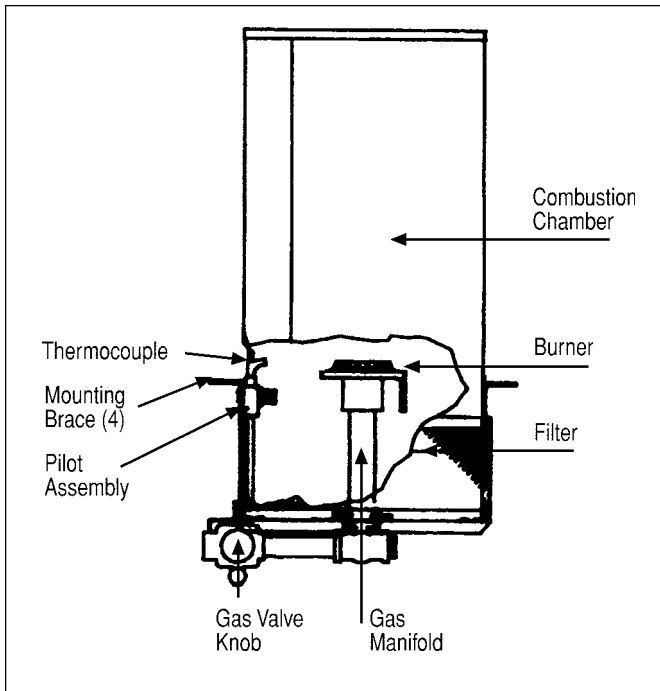

Figure 2

## REPLACEMENT PARTS LIST FOR MODELS 125-R / 125-RN

SEE BACK PAGE FOR PARTS ORDERING INFORMATION

REF. #	ITEM #	DESCRIPTION
1	00332	Manual Control Valve
2	04466	Filter/Diffuser
3	05363	Orifice Pilot(125-R)
4	09352	Thermocouple
5	11357	Pilot Burner
6	11695	Regulator (125-R)
7	11666	Regulator (125-RN)
8	05374	Orifice Pilot (125-RN)
9	CR805	Ignitor
10	CR835	Piezo
11	CR820	Axle
12	CR815	Axle Brackets
13	CR810	Wheel



GAS-FIRED INFRA-RED PORTABLE CONSTRUCTION HEATER  
MODELS 125-RN / 125-R

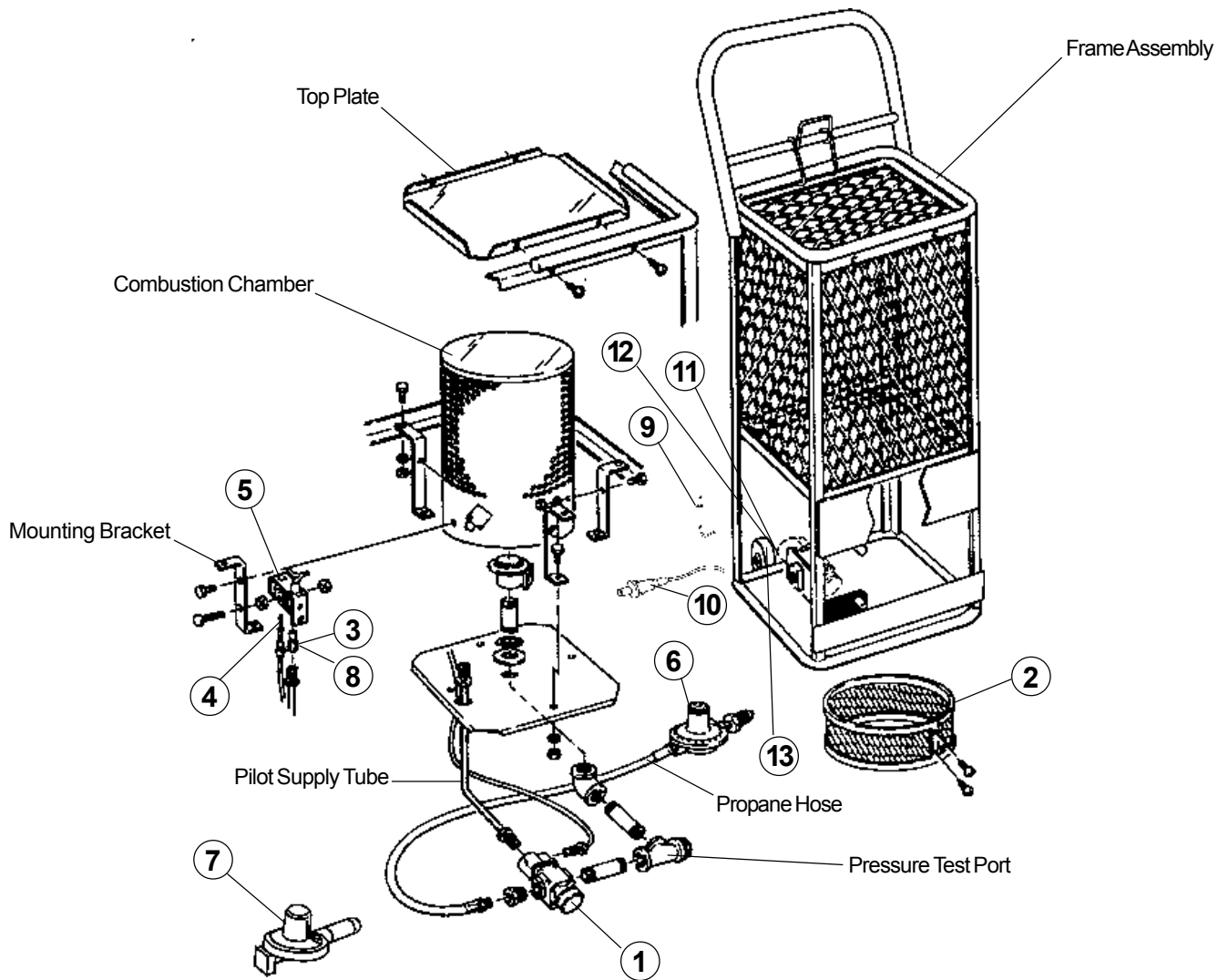





A Scheu Company

# OPERATING INSTRUCTIONS AND OWNER'S MANUAL

Model # 125-R / 125-RN

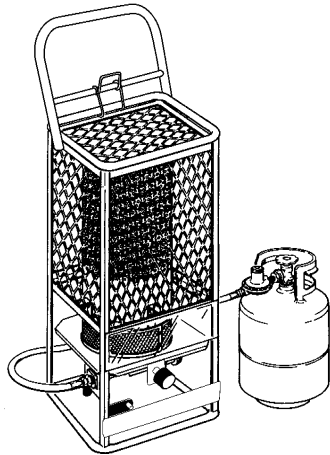

## WARNING:

USE ONLY MANUFACTURER'S REPLACEMENT PARTS. USE OF ANY OTHER PARTS COULD CAUSE INJURY OR DEATH. REPLACEMENT PARTS ARE ONLY AVAILABLE DIRECT FROM THE FACTORY AND MUST BE INSTALLED BY A QUALIFIED SERVICE AGENCY.

## PARTS ORDERING INFORMATION:

**PURCHASING:** Accessories may be purchased at any Scheu Products Co. local dealer or direct from the factory

## FOR INFORMATION REGARDING SERVICE

Please call Toll-Free 888-619-7060  
E-Mail Address: [php@scheuco.com](mailto:php@scheuco.com)

Our office hours are 7:00 AM – 4:00 PM, CT, Monday through Friday.

Please include the model number, date of purchase, and description of problem in all communication.

## WARRANTY

Gas Fired Infra Red Portable Construction Heater 125-RN & 125-R.

Scheu Products Co.. warrants that Infra Red Heaters manufactured and sold will be free from defects in material and workmanship.

Parts assemblies controls, etc. furnished by Scheu Products Co. will carry a one (1) year warranty on the applicable warranties of the suppliers.

The sole responsibility of Scheu Products Co. under this warranty shall be to replace or repair any part for which a written claim is made to Scheu Products Co.. within the time limit of this warranty which is returned upon request to Scheu Products Co. F.O.B. Rancho Cucamonga, CA. or F.O.B. an Scheu Products Co.. authorized service facility and which is proved to be defective upon inspection by Scheu Products Co..

This warranty shall not apply to any part or product which has been subjected to misuse or neglect, damaged by accident, or rendered defective by reason of improper installation. THIS WARRANTY IS IN LIEU OF ANY AND ALL OTHER WARRANTIES, EXPRESSED OR IMPLIED, and of any other responsibility of Scheu Products Co. for parts or products sold by Scheu Products Co., including consequential or special damages.

Scheu Products Co. reserves the right to make changes at any time, without notice or obligation, in colors, specifications, accessories, materials and models.



ANSI Z83.7/CGA 2.14-2000