

Series M

Panel meters 96x48mm



Model M40-T

Pt100/RTD
Thermocouples

Panel meter for Pt100/RTD (2 and 3 wires), and thermocouples J, K, T, E, S, R, N, C, L and X with temperature display in degrees celsius (°C) or fahrenheit (°F). Selectable Pt100/RTD resolution at 1° or 0.1°, and manual offset available. Thermocouple measure with internal CJC selectable (enabled or disabled). Selectable behavior in case of sensor break ('to_high' or 'to_low'). Size 96x48mm. Reading with 4 digits. Maximum and minimum display memory, steps, alarms with single or double setpoints, 5 levels of brightness, ... Universal AC and DC power modules and up to 3 modules for signal retransmission and control (relay outputs, analogue outputs, ...).

1. Meter M40-T

Panel meter 96x48mm size for Pt100/RTD and thermocouples

Panel meter for temperature signals, accepts Pt100/RTD with 2 and 3 wires, and thermocouples J, K, T, E, S, R, N, C, L and X. Temperature display in degrees celsius (°C) or fahrenheit (°F). Thermocouple cold junction compensation selectable. Manual offset selectable. Selectable behavior for alarms in case of sensor break ('to_high' or 'to_low').

Instrument with 96x48mm standard DIN size. Resolution 4 digits plus negative sign.

Management for up to 3 alarms with 1 or 2 setpoints each alarm, with hysteresis and delays. Provides memory for maximum and minimum, display on selectable steps, password and selectable levels of brightness.

Power options with universal AC and DC ranges, and space for 3 additional control and/or signal retransmission modules.

Standard IP54 front protection, with optional upgrade to IP65 protection. Optional with green led.

Connections via plug-in screw terminals and configuration via three front push-buttons. For application on industrial environments.

1.1 Order reference

Model	Power	Option1	Option2	Option3	Others
M40	T	H	---	---	---
	-H (85-265 Vac/dc) -L (11-60 Vdc and 24/48 Vac)	-R1 (1 relay) -AO (Analogue output) - (empty)	-R1 (1 relay) -AO (Analogue output) - (empty)	-R1 (1 relay) -AO (Analogue output) - (empty)	-65 (IP65) -G (green led) - (empty)

Index

1. Meter M40-T	2	1.11 Default factory configuration	9
1.1 Order reference	2	1.12 Messages and errors	9
1.2 Front View	3	1.13 Information menu	10
1.3 Rear View	3	1.13.1 Information menu	10
1.4 Power Connections	3	1.14 Accessing the instrument	10
1.5 Signal connections - Pt100 / RTD	3	1.15 Warranty	11
1.6 Signal connections - Thermocouples	3	1.16 Installation precautions	11
1.7 Technical data	4	1.17 CE declaration of conformity	11
1.7 Technical data (cont.)	4	2. Output and control modules	12
1.8 Mechanical dimensions (mm).	5	2.1 Module R1	12
1.9 Operating the menus	6	2.2 Module AO	12
1.10 Configuration menu	6	2.3 Modules R2, R4, R6	13
1.10 Configuration menu (cont.)	7	3. More options and accessories	14
1.10.1 Input menu	8	7.1 Option NBT	14
1.10.2 Temperature configuration	8	7.2 Option G	14
1.10.3 Alarms	8	7.3 Option IP65	14
1.10.4 Display	8	7.4 Benchtop housing THM	14
1.10.5 Tools	8	7.5 Adapter DRA-M	14
1.10.6 Menu OptX - Options.	9		

1.2 Front View

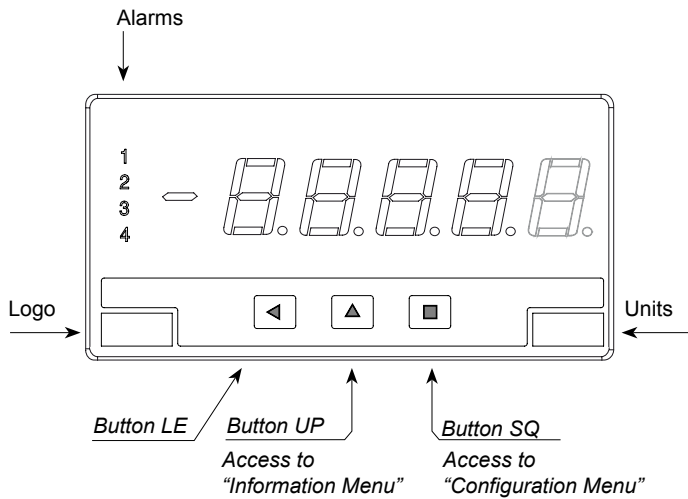

1.3 Rear View

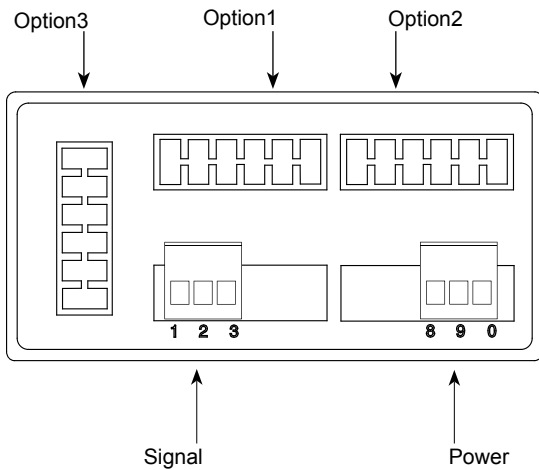

1.4 Power Connections

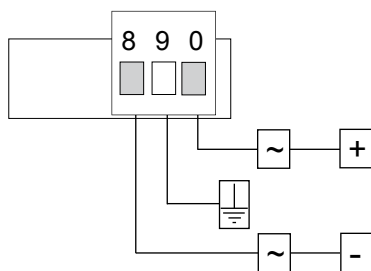

Earth connection - Although a terminal is offered for earth connection, the connection is optional. The instrument does not need this connection for correct functioning nor for compliance with the security regulations.

Fuse - To comply with security regulation 61010-1, add to the power line a protection fuse acting as disconnection element, easily accessible to the operator and identified as a protection device.

- Power "H" fuse 250mA time-lag
- Power "L" fuse 400mA time-lag

1.5 Signal connections - Pt100 / RTD

Measure can be selected for 2 or 3 wire systems.

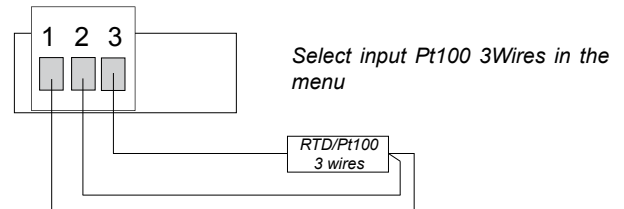
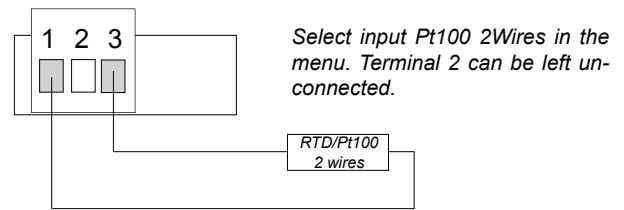

1.6 Signal connections - Thermocouples

To configure, select the appropriate thermocouple type in the configuration menu.

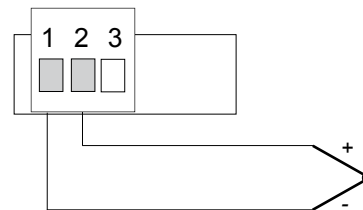

1.7 Technical data

Digits 4
 Type 7 segments, red
 Height 14 mm
 Display maximum 9999
 Display minimum -9999
 Decimal point selectable 8.8.8.8.
 Overrange 9999 flashing
 Underrange -9999 flashing

Signals accepted Pt100/RTD and Thermocouples
 Temperature scale ITS90
 Display units °C or °F, selectable

Thermocouple data

Thermocouples accepted J, K, T, E, S, R, N, C, L, X
(Thermocouple X is a linear 10uV/°C signal)
 Resolution 1°
 Ranges see table 3
 Max. error at 25°C see table 3
 Offset drift see table 3
 Span drift* see table 3
**Note - span drift includes also the offset drift*
 CJC automatic ("On"/"Off" selectable)
 CJC accuracy <1.0°C
 CJC thermal drift <0.04°/°C
 On sensor break "to_high" or "to_low", selectable
 Acquisitions 3 acquisitions / second

Pt100/RTD data

Sensors accepted 2 or 3 wire, selectable
 Resolution 1° or 0.1°, selectable
 Ranges see table 3
 Alpha Alpha385 or Alpha390, selectable
 Max. error at 25°C see table 3
 Offset drift see table 3
 Span drift * see table 3
**Note - span drift includes also the offset drift*
 Cable compensation up to 14 Ohm
 Compensation accuracy <0.02°C / Ohm
 Acquisitions 4 acquisitions / second

1.7 Technical data (cont.)

Power
 Power "H" 85 to 265 Vac/dc
 Power "L" 11 to 60 Vdc and 24/48Vac
 Consumption <4W
 Isolation 3500Veff for power "H"
 2000Veff for power "L"
 all levels tested for 60 seconds

Configuration 3 frontal push buttons

Functions available

Steps yes, configurable
 Memory of maximum yes
 Memory of minimum yes
 Password yes, configurable
 Double setpoints yes
 Brightness control yes, 5 levels

Optional boards 3 free slots

Mechanical

Mounting panel
 Connections plug-in screw terminals
 Weight <150 grams
 Housing materials ABS, polycarbonate
 Front size 96x48mm
 Panel cut-out 92x44mm
 Deep from panel 91mm (including terminal)

Protection

IP54 standard
 IP65 optional (Front sealed. Opening the front breaks the seal)

Temperature Operation 0 to 50°C
 Temperature Storage -20 to +70°C
 Warm-up 15 minutes

Type	Range °C	Max. error at 25°C*	Range °F	Offset drift	Span drift* *includes offset drift
Pt100/RTD	800 / -200 °C	<0.2°C	1562 / -328 °F	0.05°/°C	0.10°/°C
Thermocouple J	1200 / -200 °C	<2°C	2192 / -328 °F	0.05°/°C	0.20°/°C
Thermocouple K	1372 / -200 °C	<2°C	2372 / -328 °F	0.05°/°C	0.20°/°C
Thermocouple T	400 / -200 °C	<2°C	752 / -328 °F	0.02°/°C	0.02°/°C
Thermocouple E	1000 / -200 °C	<2°C	1832 / -328 °F	0.05°/°C	0.20°/°C
Thermocouple S	1768 / -50 °C	<4°C	2282 / -58 °F	0.20°/°C	0.20°/°C
Thermocouple R	1600 / -50 °C	<4°C	2912 / -58 °F	0.20°/°C	0.20°/°C
Thermocouple N	1300 / -200 °C	<2°C	2372 / -328 °F	0.05°/°C	0.20°/°C
Thermocouple C	2320 / 0 °C	<2°C	4192 / 32 °F	0.02°/°C	0.02°/°C
Thermocouple L	900 / -200 °C	<2°C	1652 / -328 °F	0.05°/°C	0.20°/°C
Thermocouple X	4000 / -200 °C	<2°C	7232 / -328 °F	0.02°/°C	0.02°/°C

Table 3 - Thermocouple and PT100/RTD specifications

1.8 Mechanical dimensions (mm)

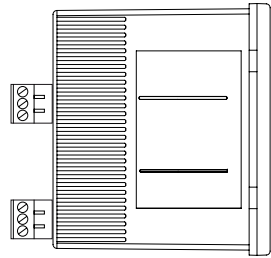
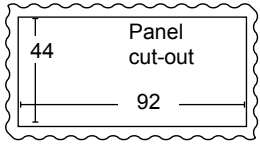
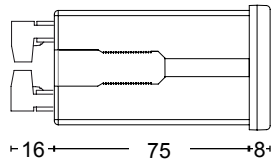
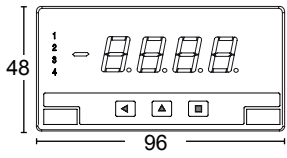

This section blank

1.9 Operating the menus

The instrument has two menus accessible to the user :

“Configuration Menu” (key SQ)

“Information Menu” (key UP)

The “Configuration Menu” allows to change the configuration of the instrument. Access to the “Configuration Menu” can be password protected with the function “PASSWORD”. During operation with the “Configuration Menu” the alarms are kept “on-hold”. When leaving the “Configuration Menu” the instrument performs a restart, and new configuration is applied. On restart of the instrument, also the control output modules are restarted (relays, analogue outputs, ...).

The “Information Menu” is for information only, and it does not accept changes on the displayed information. To enter the “Information Menu” press the “UP” button. It is not affected by the “PASSWORD” function. Leaving the “Information Menu” returns to the measuring state of the instrument, without restart of the unit.

Rollback - After 30 seconds without interaction from the operator, the instrument leaves the menu and returns to the previous working mode. In case of configuration menu, all changes are discarded.

Button SQ - Selects the menu entry currently displayed. When entering a numeric value (for example a setpoint value) validates the value on display.

Button UP - Moves vertically on the menu entries. When entering a numeric value (for example a setpoint value) modifies the current digit by increasing its value up from 0 to 1, 2, 3, 4, 5, 6, 7, 8, 9.

Button LE - Leaves the current menu. Pressing LE several times will leave all menus. When leaving all menus in the configuration menu, changes will be saved. When entering a numeric value (for example a setpoint value) it moves from one digit to the next. Each digit value can then be modified with the UP button.

1.10 Configuration menu

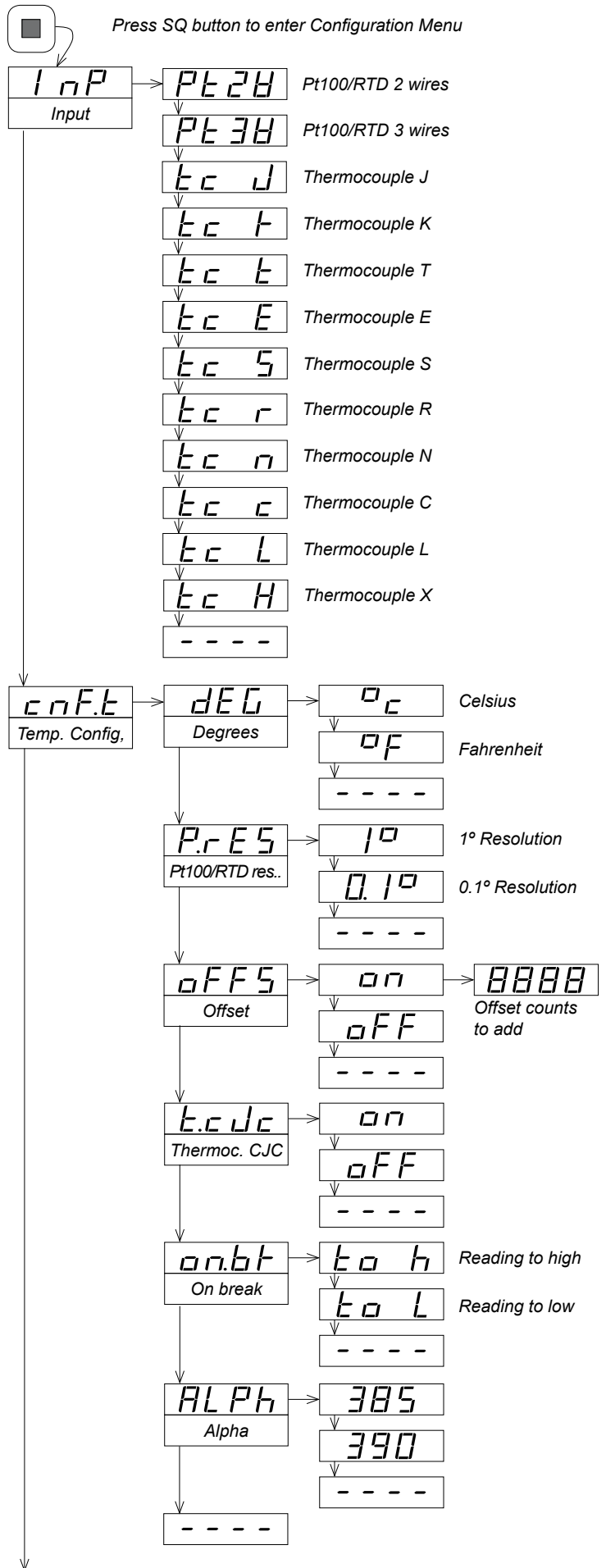

1.10 Configuration menu (cont.)

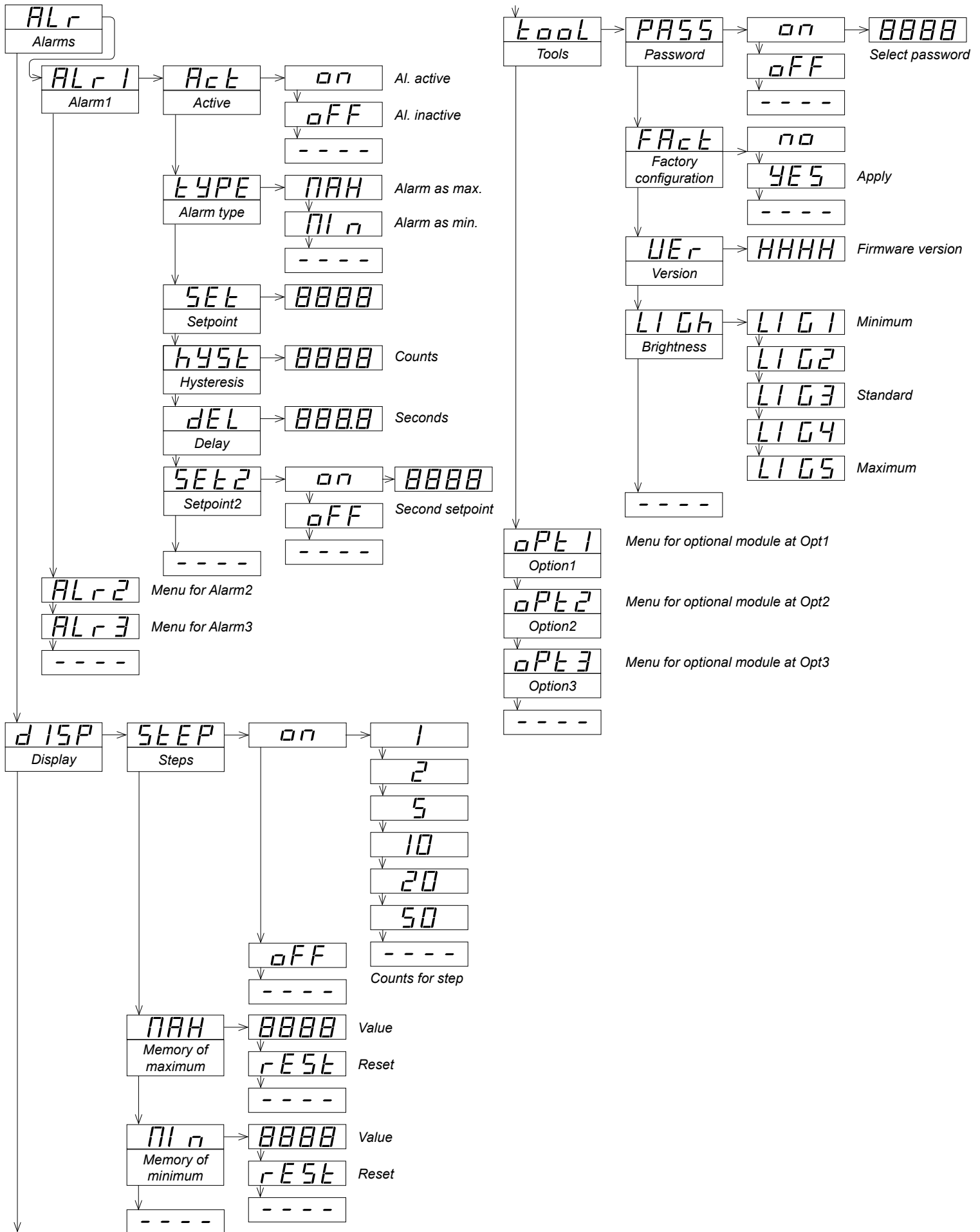

1.10.1 Input menu

The input menu selects the input signal range. Options available are Pt100/RTD 2 or 3 wires, and thermocouples J, K, T, E, S, R, N, C, L and X.

Note - Thermocouple X is a linear signal at 10uV/°C.

1.10.2 Temperature configuration

The temperature configuration menu sets the function parameters for Pt100/RTD and thermocouple sensors.

Degrees (DEG) - Value "°C/°F". Select the temperature to be displayed in celsius or fahrenheit degrees.

Pt100/RTD resolution (P.RES) - Value "1°/0.1°". Resolution for the Pt100/RTD. Select to display with degree or tenth of degree resolution.

Offset (OFFS) - Value from "-9999" to "9999" counts. Offset to be added to the reading. Both for Pt100/RTD and thermocouples.

Thermocouple Cold Junction Compensation (T.CJC) - Value "On/Off". Select "On" for automatic CJC compensation in the instrument. Select "Off" to disable the CJC compensation.

On break (ON.BK) - Value "to_h/to_l". Select "To L" to make the reading go to minimum, in case of probe broken. Select "To H" to make the reading go to maximum in case of probe broken.

Alpha (ALPH) - Value "385/390". Select "385" or "390" according to your Pt100/RTD sensor.

1.10.3 Alarms

The instrument can manage up to 3 alarms. These alarms control optional relays R1 (see section 2.1) which can be installed at slots Opt1, Opt2 and Opt3. More alarms can be achieved by installing special control modules R2, R4 and R6. Configuration menus for special modules are not listed in this document.

Active (ACT) - Value "ON/OFF". Defines if the instrument has to manage this alarm or not. Select "OFF" for alarm not managed.

Type (TYPE) - Value "MAX/MIN". Defines the behavior of the alarm as maximum or minimum alarm. The alarms configured as maximum are activated when the display value is equal or higher than the setpoint. The alarms configured as maximum are deactivated when the display is lower than the setpoint. The alarms configured as minimum have the inverse behavior.

Setpoint (SET) - Value from "9999" to "-1999". Alarm set point.

Hysteresis (HYSt) - Value from "0" to "9999". Points of hysteresis. The hysteresis applies on the deactivation of the alarm.

Delay (DEL) - Value from "0.0" to "99.9" seconds. Delay to be applied to the relay activation and deactivation. Relays are activated and deactivated X seconds after the activation / deactivation of the alarm. The delay affects only to the relays. The delay does not affect to the front leds.

Setpoint2 (SET2) - Value from "-1999" to "9999". Second setpoint. The second setpoint allows for the creation of activation windows. If the alarm is configured as maximum with setpoint 1000 and setpoint2 is configured at 1500, the alarm will be activated between 1000 and 1500 and the alarm will be deactivated when display is <1000 and >1500. Setpoint2 is affected on the same way as the setpoint with hysteresis and delays.

1.10.4 Display

Functions on this menu allow for configuration of the visualization.

Steps (STEP) - Display changes on predefined steps. Values are 1, 2, 5, 10, 20 and 50. The display is made in steps of X counts. For example, select a step of 20 will make the display to change in steps of 20 (1420, 1440, 1460, ...).

Maximum (MAX) - Memory of maximum display. Indicates the maximum value of display since the last reset of the memory. Memory is reset on the following cases : manual reset from the Configuration Menu (Maximum), change on the input signal (Input), modification on the scaling (Scaling), change on the decimal point (dP), modification of the linearization segments, or instrument power-down.

Minimum (MIN) - Memory of minimum display. Indicates the minimum value of display since the last reset of the memory. Memory is reset on the following cases : manual reset from the Configuration Menu (minimum), change on the input signal (Input), modification on the scaling (Scaling), change on the decimal point (dP), modification of the linearization segments, or instrument power-down.

1.10.5 Tools

Password (PASS) - Select a number to act as password. This password will be requested when entering the Configuration Menu. To deactivate the password select "Off".

Factory Settings (FACT) - Factory default configuration. Select "yES" to activate the factory default configuration.

Version (VER) - Firmware version installed.

Light (LIGH) - Luminosity. Select between 5 predefined levels of luminosity.

1.10.6 Menu OptX - Options

Menu options OPT1, OPT2 and OPT3 give access to the configuration menus of the options installed at slots Opt1, Opt2 and Opt3. This menu depends on the installed option. If there is no option installed the instrument shows "NONE". Control modules R1 are controlled from the standard alarm menu (see section 1.12.7).

1.11 Default factory configuration

Sensor	Pt100 2Wire
Degrees	°C
Resolution	0.1°
Offset	0
On Break	To high
Alpha	385
Alarms 1,2 and 3	
Active	Off (not managed)
Type	maximum
Setpoint	1000
Hysteresis	0 counts
Delay	0.0 seconds
Setpoint2	Off
Display	
Steps	Off
Memory of maximum	-9999
Memory of minimum	9999
Tools	
Password	Off
Brightness	3

1.12 Messages and errors

When the instrument detects that the displayed value does not correspond to the input value, the display will flash and alternate with a message.

"h.udr" Hardware underrange. The thermocouple signal is lower than minimum readable signal (-30mV).

"h.oVr" Hardware overrange. The thermocouple signal is higher than maximum readable signal (80mV).

"d.udr" Display underrange. The Pt100/RTD is shortcircuited.

"hoLd" The instrument is showing the value present when the hold function was activated. Hold function is active.

"Min" The instrument displays the minimum displayed value in memory. The minimum visualization is active.

"MAX" The instrument displays the maximum displayed value in memory. The maximum visualization is active.

"brk" The instrument displays "brk" with either "9999" or "-9999" when : 1) resistance measured is higher than 390 Ohms (higher than 850°C for PT100/RTD measure), or 2) in case the third wire ohm is higher than 15 Ohm, or 3) thermocouple measure is open circuit.

"Err.1" Password incorrect.

"Err.2" The instrument has detected an installed option but was unable to communicate.

"E.101" Option is installed but the type can not be recognized.

1.13 Information menu

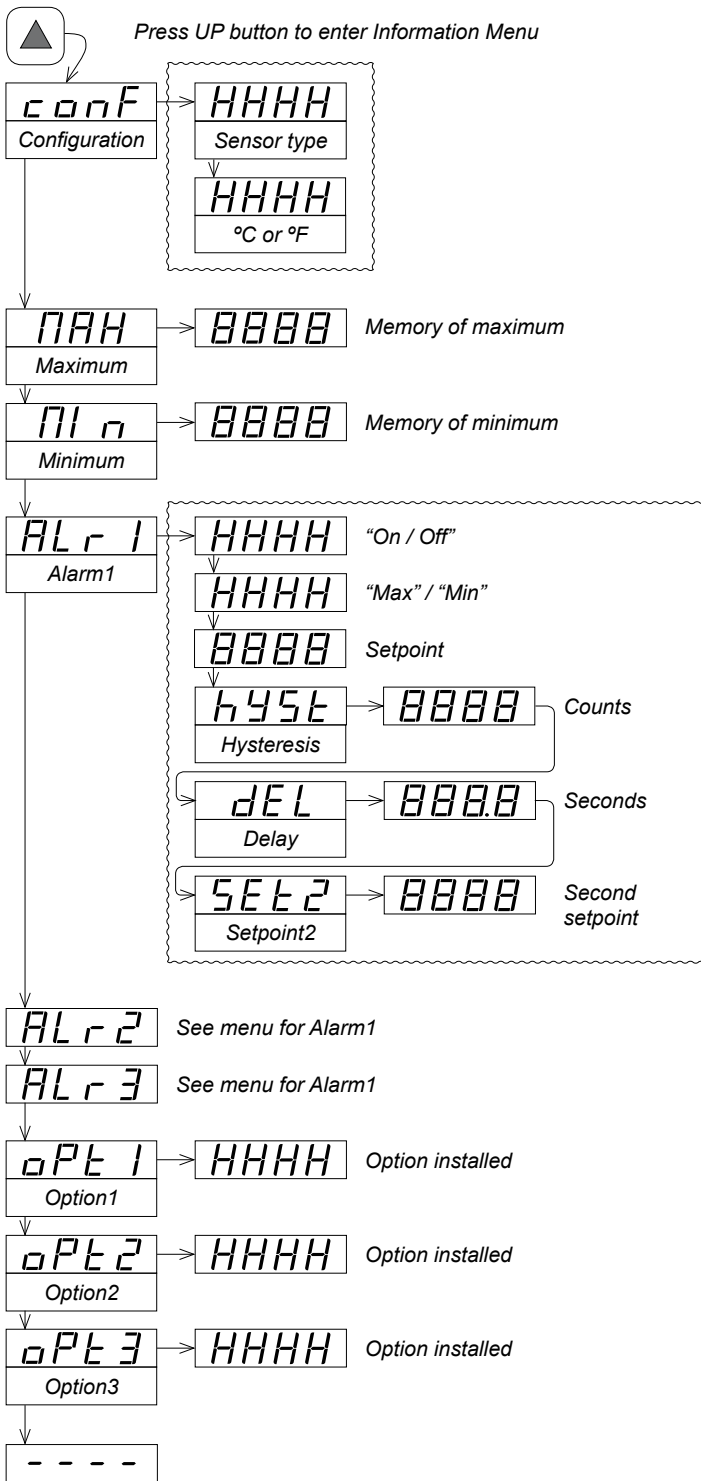

1.13.1 Information menu

Configuration (Conf) - Information on the configured input sensor and the degrees selected.

Maximum (MAX) - Value of the maximum display.

Minimum (Min) - Value of the minimum display.

AlarmX (ALX) - Configuration of alarm X. The sequence of information shows if the alarm is being managed ("On/Off"), the alarm type ("Max/Min"), the setpoint, the hysteresis value, the activation delay and the value of setpoint2 ("Off" or the setpoint2 value).

OptionX (OptX) - Type of module installed. If there is no module shows "nonE".

1.14 Accessing the instrument

You may need to access the inside of the instrument to insert additional modules. Use a flat screwdriver to unlock the upper clips marked with "A". Then unlock the lower clips marked with "B" and move out the front filter. Let the inside of the instrument slide out of the housing.

To reinsert the instrument make sure that all modules are correctly connected to the pins on the display module. Place all the set into the housing, assuring that the modules correctly fit into the internal guiding slides of the housing. Once introduced, place again the front filter by clipping first the upper clips "A" and then the lower clips "B".

Important - If your instrument was delivered with the IP65 front seal option, accessing the inside of the instrument will permanently break the IP65 seal on the areas of clips "A" and "B".

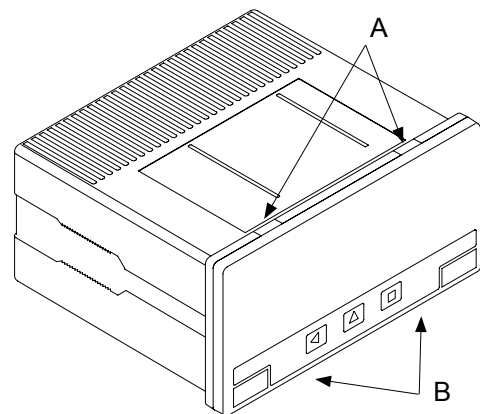

Risk of electric shock. Removing the front cover will grant access to the internal circuits. Disconnect the input signal to prevent electric shock to the operator. Operation must be performed by qualified personnel only.

1.15 Warranty

All instruments are warranted against all manufacturing defects for a period of 24 MONTHS from the shipment date. This warranty does not apply in case of misuse, accident or manipulation by non-authorized personnel. In case of malfunction get in contact with your local provider to arrange for repair. Within the warranty period and after examination by the manufacturer, the unit will be repaired or substituted when found to be defective. The scope of this warranty is limited to the repair cost of the instrument, not being the manufacturer eligible for responsibility on additional damages or costs. .

1.16 Installation precautions



Risk of electrical shock. Instrument terminals can be connected to dangerous voltage.



Instrument protected with double isolation. No earth connection required.



Instrument is in conformity with CE rules and regulations. See "CE Declaration of Conformity" further in this document.

This instrument has been designed and verified according to the 61010-1 CE security regulation, and is designed for applications on industrial environments. See the "CE Declaration of Conformity" further in this document for information on the category of measure and the degree of pollution levels that apply.

Installation of this instrument must be performed by qualified personnel only. This manual contains the appropriate information for the installation. Using the instrument in ways not specified by the manufacturer may lead to a reduction on the specified protection level. Disconnect the instrument from power before starting any maintenance and / or installation action.

The instrument does not have a general switch and will start operation as soon as power is connected. The instrument does not have protection fuse, the fuse must be added during installation.

The instrument is designed to be panel mounted. An appropriate ventilation of the instrument must be assured. Do not expose the instrument to excess of humidity. Maintain clean by using a humid rag and do NOT use abrasive products such as alcohols, solvents, etc.

General recommendations for electrical installations apply, and for proper functionality we recommend : if possible, install the instrument far from electrical noise or magnetic field generators such as power relays, electrical motors, speed variators, ... If possible, do not install along the same conduits power cables (power, motor controllers, electrovalves, ...) together with signal and/or control cables.

Before proceeding to the power connection, verify that the voltage level available matches the power levels indicated in the label on the instrument.

In case of fire, disconnect the instrument from the power line, fire alarm according to local rules, disconnect the air conditioning, attack fire with carbonic snow, never with water.

1.17 CE declaration of conformity

Manufacturer FEMA ELECTRÓNICA, S.A.
Altimira 14 - Pol. Ind. Santiga
E08210 - Barberà del Vallès
BARCELONA - SPAIN
www.fema.es - info@fema.es

Products - M40-T

The manufacturer declares that the instruments indicated comply with the directives and rules indicated below.

Directive of electromagnetic compatibility 2004/108/CEE
Directive of low voltage 73/23/CEE

Security rules 61010-1

Equipment "Fixed"
"Permanently connected"
Pollution Degree 1 and 2 (without condensation)
Isolation Double

Emission rules

61000-6-4 Generic rules of emission

Immunity rules

61000-6-2 Generic rules of immunity
61000-4-2 By contact $\pm 4\text{KV}$ - Criteria B
On air $\pm 8\text{KV}$ - Criteria B

61000-4-3 Criteria A

61000-4-4 On AC power lines: $\pm 2\text{KV}$ - Criteria B
On DC power lines: $\pm 2\text{KV}$ - Criteria B
On signal lines : $\pm 1\text{KV}$ - Criteria B

61000-4-5 Between AC power lines $\pm 1\text{KV}$ - Criteria B
Between DC power lines $\pm 0.5\text{KV}$ - Criteria B

61000-4-6 Criteria A

61000-4-8 30A/m at 50Hz - Criteria A
61000-4-11 0% 1 cycle Criteria A
40% 10 cycle Criteria B
70% 25 cycle Criteria B
0% 250 cycle Criteria B

Barberà del Vallès November 2011
Daniel Juncà - Quality Manager

2. Output and control modules

2.1 Module R1

Module with 1 relay. Up to a maximum of three R1 modules can be installed in one M Series panel meter. For more relay output needs, check special modules R2, R4 and R6. For more information see document *2654_M-SERIES_OPTIONAL_MODULES* at www.fema.es

Relay type	3 contacts (Common, NC, NO)
Maximum current	8A (resistive load)
Voltage	250 Vac continuously
Installable at	Option1 and/or Option2 and/or Option3

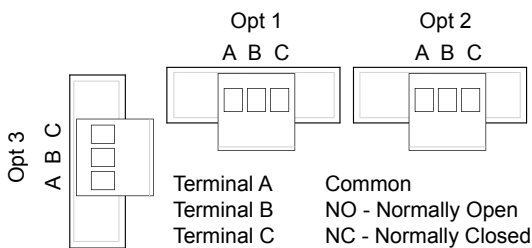

2.2 Module AO

Module with 1 analogue output. Configurable 4/20mA or 0/10Vdc. Output signal proportional to the reading. Scaling through the frontal keypad. Up to a maximum of three AO modules can be installed in one M Series panel meter. For more information see document *2654_M-SERIES_OPTIONAL_MODULES* at www.fema.es

Output	4/20mA, 0/10Vdc selectable
Accuracy	0.1% FS
Isolated	yes, 1000Vdc
Thermal drift	50 ppm/°C for Vdc 60 ppm/°C for mA
Installable at	Option1 and/or Option2 and/or Option3

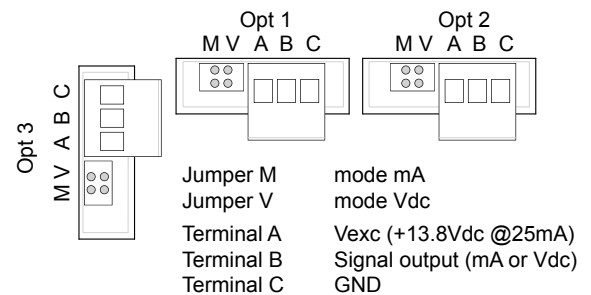

2.3 Modules R2, R4, R6

Special modules with 2, 4 and 6 relays. Use special modules R2, R4 or R6 when standard R1 modules do not provide required functionality for your application. Only one special module R2, R4 or R6 can be installed in an M Series panel meter. Special modules R2, R4 and R6 are not compatible with R1 modules.

Configuration is done through the OPTx entry of the configuration menu. Functionality for R2, R4 and R6 modules differs from standard R1 modules. For more information see document *2654_M-SERIES_OPTIONAL_MODULES* at www.fema.es

Number of relays	2, 4 or 6
Relay type	3 contacts (Common, NO, NC)
Maximum current	6A (resistive load) (each relay)
Voltage*	250 Vac continuously
Installable at slot	Opt.1. R2 fills OPT1 R4 fills OPT1 and OPT2 R6 fills OPT1 and OPT2 and OPT3
Terminal	Plug-in screw terminals pitch 3.81mm

* Terminals approved for 300V (according to UL1059, groups B and D) and 160V (according to VDE in CAT-III and pollution degree 3).

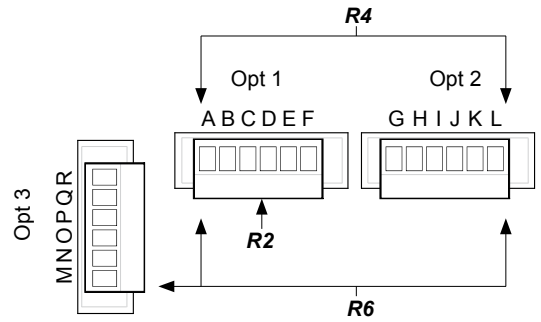

Terminal A	Relay1 Common
Terminal B	Relay1 NO - Normally Open
Terminal C	Relay1 NC - Normally Closed
Terminal D	Relay2 Common
Terminal E	Relay2 NO - Normally Open
Terminal F	Relay2 NC - Normally Closed
Terminal G	Relay3 Común
Terminal H	Relay3 NO - Normally Open
Terminal I	Relay3 NC - Normally Closed
Terminal J	Relay4 Common
Terminal K	Relay4 NO - Normally Open
Terminal L	Relay4 NC - Normally Closed
Terminal M	Relay5 Common
Terminal N	Relay5 NO - Normally Open
Terminal O	Relay5 NC - Normally Closed
Terminal P	Relay6 Common
Terminal Q	Relay6 NO - Normally Open
Terminal R	Relay6 NC - Normally Closed

3. More options and accessories

7.1 Option NBT

Panel meter without frontal key pad. To configure the instrument, uninstall from the panel and remove the front cover. Once the front cover is removed, internal push-buttons are accessible. Optionally, order the instrument configured from factory.



Risk of electric shock. Removing the front cover will grant access to the internal circuits. Disconnect the input signal to prevent electric shock to the operator. Operation must be performed by qualified personnel only.



7.2 Option G

Green led option.



7.3 Option IP65

This option provides M series panel meters with IP65 front protection. The instrument is provided with the front cover sealed.

NOTE - Removing the front cover to access the inside of the instrument will permanently disable the IP65 protection (see section 1.14).

7.4 Benchtop housing THM

Benchtop housing for M series of panel meters. Handle with three selectable positions and power connector with manual switch and fuse holder.



7.5 Adapter DRA-M

Adapter for DIN rail mount.



This page blank

other products



Panel Meters
Standard 96x48mm



Panel Meters
Small 72x36mm



Panel Meters
Miniature 48x24mm



Large Displays
60&100mm digit



Signal Converters
& Isolators



Bar Meters

www.fema.es

ELECTRONIC INSTRUMENTATION FOR INDUSTRY

FEMA ELECTRÓNICA, S.A.
Altimira 14 - Pol. Ind. Santiga
E08210 Barberà del Vallès
BARCELONA - SPAIN

Tel. (+34) 93.729.6004 - www.fema.es
Fax (+34) 93.729.6003 - info@fema.es