

Maxsine

EP1 AC SERVO

User Manual

(First edition)

Servo Drive TL08F/TL12F/TL16F

Maxsine Electric Co.,Ltd

DECLARATION

Wuhan Maxsine electric technology limited company all rights reserved.
Without this company's written permission, forbid strictly the reprint either the
part or the complete content of this handbook.

Because improves and so on the reasons, the product specification or dimension
has the change, not separate informs even slightly.

Safety Precautions

In order to use this product safely, the user should be familiar with and observes the following important items before proceeding with storage, installation, wiring, operation, inspection or maintenance for the product.



DANGER

Indicates a disoperation possibly can cause danger and physical injure or death.



CAUTION

Indicates a disoperation possibly can cause danger and physical injure, and may result in damage to the product.



STOP

Indicates a prohibited actions, otherwise can cause damage, malfunction to the product.

1. Service conditions



DANGER

- Do not expose the product in moisture, caustic gas, and ignitable gas situation. Otherwise can cause an electric shock or fire.
- Do not use the product in direct-sunlight, dust, salinity and metal powder places.
- Do not use the product in the places that has water, oil and drugs drops.

2. Wiring



DANGER

- Connect the earth terminal (PE) to earth reliably, otherwise can cause an electric shock or fire.
- Never connect the input power terminals (L1, L2, L3) to 380V power supply, otherwise can result in the servo driver damage and an electric shock or fire.
- Do not connect the output terminals (U, V, W) to AC power supply, otherwise can cause personnel casualty or fire.
- The output terminals (U, V, W) must be connected with the servo motor connections (U, V, W) correspondently otherwise can result in the servomotor flying speed that may cause equipment damage and the personnel casualty.
- Please fasten the input power terminals (L1, L2, and L3) and the output terminals (U, V, W). Otherwise may cause fire.
- Referring to wire selection guide, please install all wires with an adequate cross-section. Otherwise may cause fire.

3. Operations



CAUTION

- Before operating the mechanical device, it is necessary to set the parameters with appropriate values.

Otherwise, can cause the mechanical device to out of control or break down.

- Before running the mechanical device, make sure the emergency stop switch can work at any time.
- Performing trial run without load, make sure that the servomotor is in normal operation. Afterwards joins again the load.
- Please do not turn on and off the main power supply more frequently, otherwise can cause the servo driver overheat.

4. Running



- Do not touch any moving parts of the mechanical device while the servomotor is running, otherwise can cause personnel casualty.
- Do not touch servo driver and servomotor while the equipment is operating, otherwise can result in an electric shock or in burn.
- Do not move any connection cables while the equipment is operating, otherwise can result in physical injure or equipment damage.

5. Maintenance and inspection



- Do not touch any portion inside of the servo driver and servomotor, otherwise can cause an electric shock.
- Do not remove the front cover of the servo driver while power is on, otherwise can cause an electric shock.
- Please wait at least 5 minutes after power has been removed before touching any terminal, otherwise the remaining high voltage possibly can cause an electric shock.
- Do not change the wiring while the power is on, otherwise can cause an electric shock.
- Do not disassemble the servomotor, otherwise can cause an electric shock.

6. Service ranges



This handbook involves the product for the general industry use, please do not use in some equipment which may directly harm the personal safety, such as nuclear energy, spaceflight, aeronautic equipment, and life safeguard, life-support equipment and each kind of safety equipment. Please make contact with the company if have the need of use mentioned above.

CONTENTS

Chapter 1 Product inspection and installment.....	1
1.1 Product inspection	1
1.2 Product nameplate	1
1.3 Product front panel	2
1.4 Servo driver installation.....	3
1.4.1 The environmental conditions for installation	3
1.4.2 The method of installation	3
1.5 Servo motor installation.....	4
1.5.1 The environmental conditions for installation	4
1.5.2 The method of installation	4
1.6 The definition of rotating direction for servomotor.....	5
Chapter 2 Wiring	7
2.1 System construction and wiring.....	7
2.1.1 Servo driver wiring diagram.....	7
2.1.2 Wiring explanations	8
2.1.3 Electric wire specifications.....	8
2.1.4 Servo motor and AC power supply wiring diagrams.....	9
2.1.5 Main circuit terminal explanation.....	9
2.2 X1 terminals for control signals.....	10
2.2.1 X1 terminal connector	10
2.2.2 X1 terminal signal explanation.....	11
2.2.3 X1 terminal interface type	12
2.2.4 Digital input definition.....	15
2.2.5 Digital output definition.....	16
2.3 X2 encoder signal terminals	17
2.3.1 X2 terminal connector	17
2.3.2 X2 terminal signal explanation	18
2.4 Standard wiring diagram.....	19
2.4.1 Wiring diagram for position control	19
Chapter 3 Front panel operation.....	21
3.1 Explanation of the front panel of servo driver	21
3.1.1 Front panel compositions.....	21
3.1.2 Front panel explanations.....	21
3.1.3 Data display	22
3.2 Main menu.....	22
3.3 Status monitor.....	23

3.4 Parameters setting.....	27
3.5 Parameter management.....	28
3.6 Auxiliary functions	29
3.6.1 Special functions.....	29
3.6.2 Jog function.....	29
3.6.3 Speed adjustment by keyboards.....	30
3.6.4 Zeroing for analog quantity	30
3.7 Resume the parameter default values.....	31
Chapter 4 Running.....	33
4.1 Trial running with no load.....	33
4.1.1 Wiring and inspection	33
4.1.2 Trial running in JOG mode	34
4.1.3 Trial running in speed adjustment mode with keyboard	35
4.2 Position control mode	36
4.2.1 Simple example for position control mode.....	36
4.2.2 Position commands	37
4.2.3 Electronic gear for input commands	40
4.2.4 Gains related to position control mode	45
4.3 Gain adjustment	46
4.3.1 Gain parameters	46
4.3.2 Procedure for gain adjustment	48
4.4 Resonance suppressions.....	49
4.5 Over-travel protections	50
4.6 Torque limitations.....	50
4.6.1 Parameters for torque limitations.....	50
4.7 Timing chart of operation.....	51
4.7.1 Timing chart when power supply switch on	51
4.7.2 Alarm timing chart while servo-ON is executed.....	51
4.7.3 Action timing chart while servo-ON/OFF are executed during the servo motor is in standstill	52
4.7.4 Action timing chart while servo-ON/OFF are executed during the servo motor is in motion	52
4.8 Electromagnetic holding brake	53
4.8.1 Parameters of electromagnetic holding brake.....	53
4.8.2 Make use of electromagnetic holding brake	53
Chapter 5 Parameters	55
5.1 Parameter table	55
5.1.1 Parameters of section 0.....	55
5.1.2 Parameters of section 1	57
5.2 DI function table	58

5.3 DO function table	58
5.4 Parameter description in detail	59
5.4.1 Parameters of section 0	59
5.4.2 Parameters of section 1	70
5.5 DI function description in detail	75
5.6 DO function description in detail.....	78
Chapter 6 Alarm	79
6.1 Alarm table	79
6.2 The reason and handling of alarm.....	81
Chapter 7 Specifications	89
7.1 Types of servo driver	89
7.2 Dimensions of servo driver.....	89
7.3 Specifications of servo driver	90
7.4 Adaptive table for servo motor selections.....	91
7.5 Types of servo motor	92
7.6 Servo motor wiring	92
7.6.1 Winding wiring	92
7.6.2 Holding brakes.....	92
7.6.3 Standard encoders	93
7.6.4 Wire saving encoders	93
7.7 Parameters of servo motor	94
7.7.1 Parameters of 80 series servo motor	94
7.7.2 Parameters of 110 series servo motor	95
7.7.3 Parameters of 130 series servo motor	96
7.7.4 Parameters of 150 series servo motor	98
Appendix A Model for SIEMENS numerical control system	99
A1 SIEMENS 801、802S numerical control system.....	99
A1.1 Parameters setting	99
A1.2 SIEMENS 801、802S wiring diagram.....	100

Chapter 1 Product inspection and installment

1.1 Product inspection

This product has made the complete function test before delivery, for prevented the product to be abnormal owing to shipping process, please make detail inspection as the following items after breaking the seal:

- Inspect the types of servo driver and servomotor and ensure that are the same types in the order form.
- Inspect the outward appearance of servo driver and servomotor to see any abrasion or damage; if so please do not wire to the power supply.
- Inspect the parts of servo driver and servomotor to see any loosen parts such as loosened or fallen off screw.
- Rotate the servomotor shaft by hand and should be smooth rotation. However, the servomotor with holding brake is unable to rotate directly.

If there is any break down item or abnormal phenomenon mentioned above, please contact with the dealer immediately.

1.2 Product nameplate

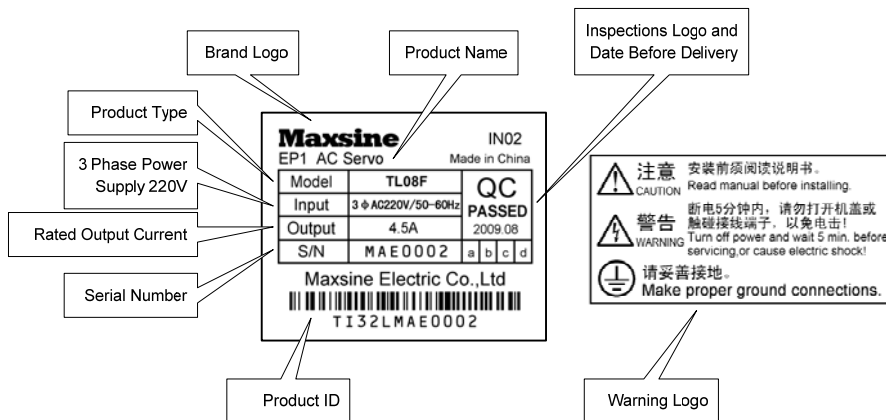

1.3 Product front panel

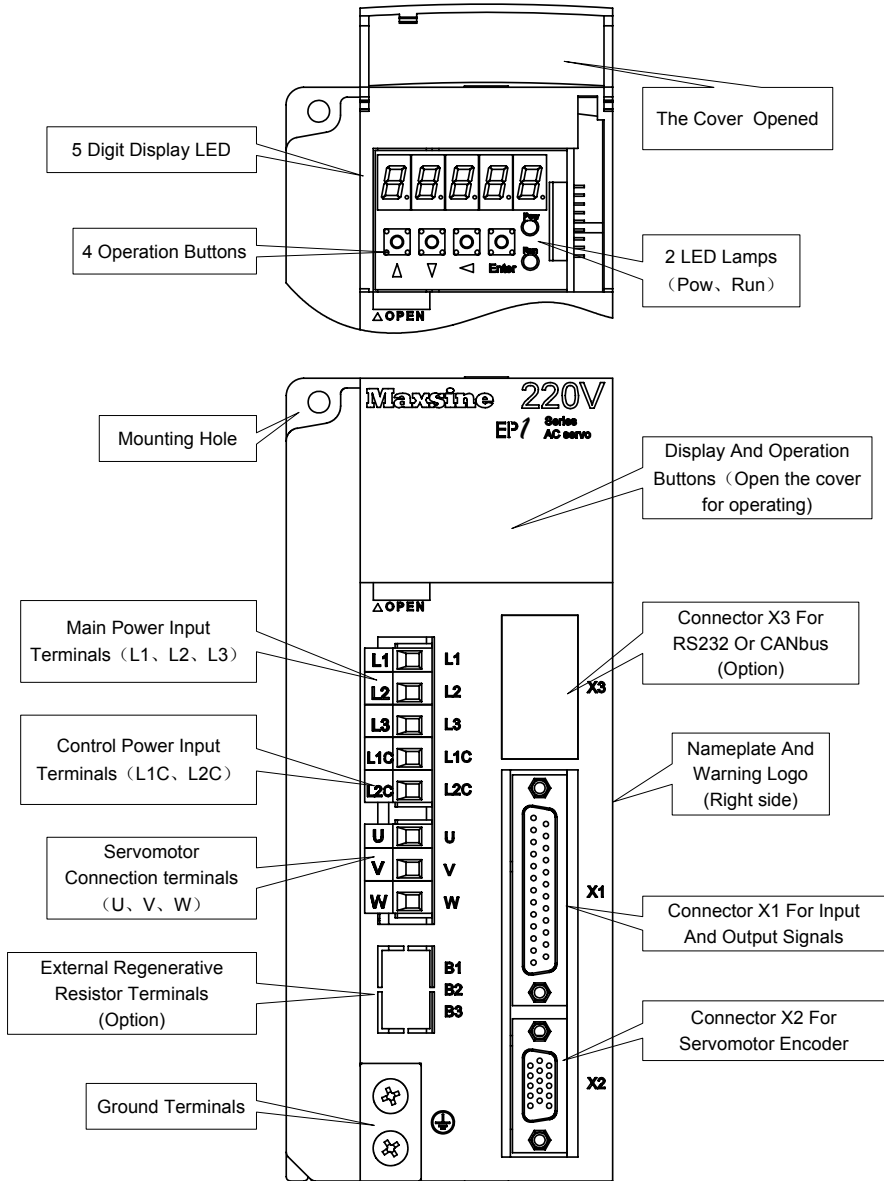

1.4 Servo driver installation

1.4.1 The environmental conditions for installation

Since the environment conditions for servo driver installation have the direct influence to the normal function and service life of the servo driver, therefore the environment conditions must be conformed to the following conditions:

- Ambient temperature: 0 to 40°C; Ambient humidity: less than 80% (no dew).
- Storage temperature: -40 to 50°C; Storage humidity: less than 93% (no dew).
- Vibration: less than 0.5G.
- Preventive measure shall be taken against raindrop or moist environment.
- Avoid direct sunlight.
- Preventive measure shall be taken against corrosion by oil mist and salinity.
- Free from corrosive liquid and gas.
- Preventive measure shall be taken against entering the servo driver by dust, cotton fiber and metal tiny particle.
- Keep away from radioactive and inflammable substances.
- When several driver installments in a control cubicle, for good ventilation please reserve enough space around each driver, install fans to provide effective cooling, keep less than 40°C for long-term trouble-free service.
- If there are vibration sources nearby (punch press for example) and no way to avoid it, please use absorber or antivibration rubber filling piece.
- If there is disturbance from interferential equipment nearby along the wirings to the servo driver can make the servo driver misoperation. Using noise filters as well as other antijamming measure guarantee normal work of the servo driver. However, the noise filter can increase current leakage, therefore should install an insulating transformer in the input terminals of power supply.

1.4.2 The method of installation

- In order to get good cooling the servo driver should normally mount in vertical direction with the topside upward.
- For installing the servo driver, fasten the backboard of the servo driver with M5 screw bolt.
- Reserve enough space around the servo drivers as shown in the reference diagram. In order to guarantee the performance of the servo driver and the lifetime, please make the space as full as possible.
- To provide vertical wind to the heat sink of the servo driver should install ventilating fans in the control cubicle.
- Prevent the dust or the iron filings entering the servo driver when install the control cubicle.

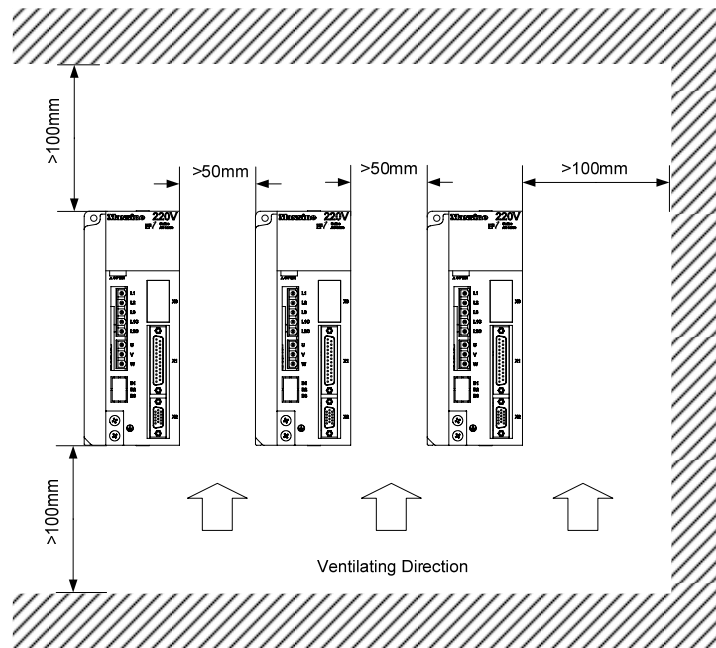

1.5 Servo motor installation

1.5.1 The environmental conditions for installation

Ambient temperature: 0 to 40°C; Ambient humidity: less than 80 % (no dew).

- Storage temperature: -40 to 50°C; Storage humidity: less than 93 % (no dew).
- Vibration: less than 0.5G.
- Install the servomotor in well-ventilated place with less moisture and a few dusts.
- Install the servomotor in a place without corrosive liquid, flammable gas, oil vapor, cutting cooling liquid, cutting chips, iron powder and so on.
- Install the servomotor in a place without water vapor and direct sunlight.

1.5.2 The method of installation

- For horizontal installation: In order to prevent water, oil, etc. from entering inside of the servomotor, please put the cable connector downward.
- For vertical installation: if the shaft of the servo motor is in upward direction with a speed reducer, some prevention measure shall be taken against entering inside of the servomotor by oil come from the speed reducer.
- Motor shaft extension should be long enough, or may cause vibration while motor is in running.
- In case of installation or removing the servomotor, please do not hit the servomotor with a hammer, otherwise the shaft and the encoder can be damaged.

1.6 The definition of rotating direction for servomotor

The motor rotating direction description in this handbook is defined as facing the shaft of the servomotor, if the rotating shaft is in counterclockwise direction will be called as positive direction, or in clockwise as reversal direction.

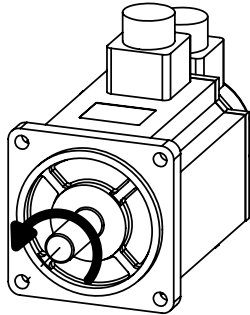

Positive Rotation
(CCW)

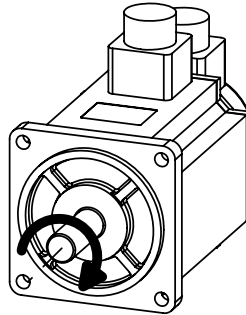

Reversal Rotation
(CW)

Chapter 2 Wiring

2.1 System construction and wiring

2.1.1 Servo driver wiring diagram

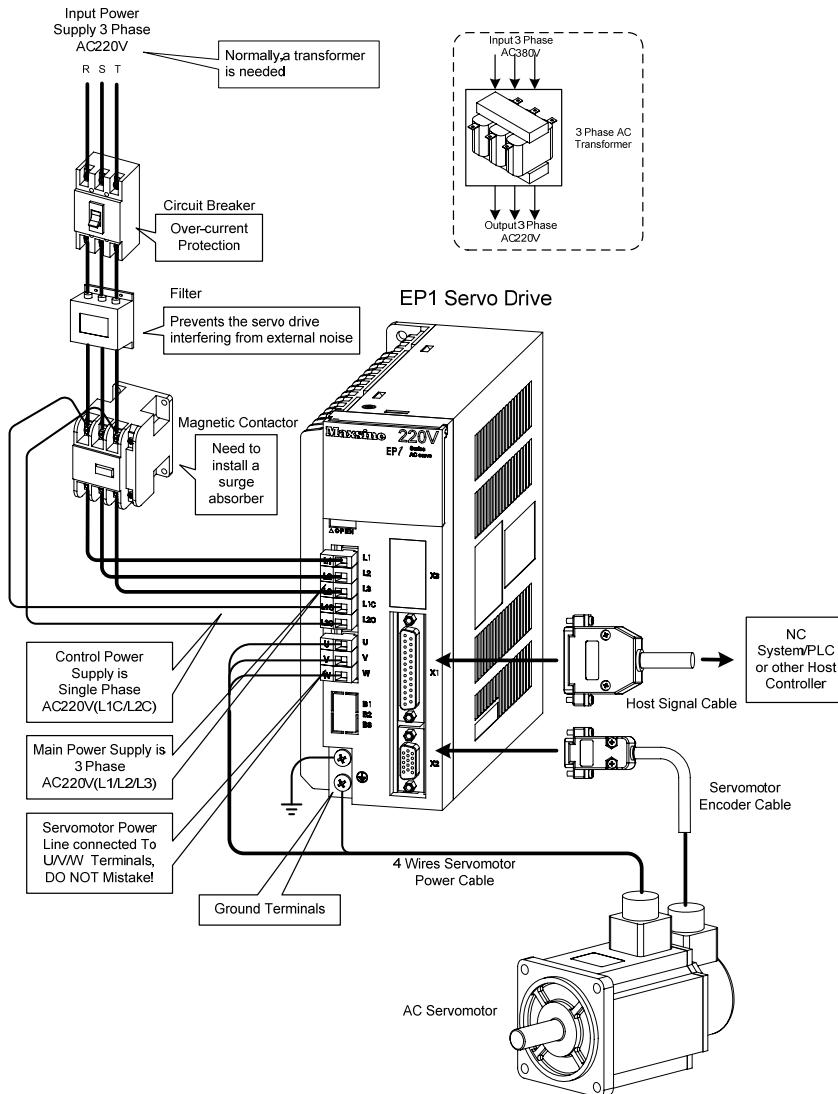

2.1.2 Wiring explanations

Wiring Notes:

- According to electric wire specification, use the wiring materials.
- The control cable length should be less than 3 meters and the encoder cable length 20 meters.
- Check that the power supply and wiring of L1, L2, L3 and L1C, L2C terminals are correct. Please do not connect to 380V power supply.
- The output terminals(U,V,W) must be connected with the servo motor connections(U,V,W) correspondently, otherwise the servo motor will stop or over speed. However, by exchanging three-phase terminal cannot cause the motor to reverse; this point is different from an asynchronous motor.
- Earthed wiring must be reliable with a single-point connection.
- Pay attention to the correct direction of freewheel diode which is connected with the relay at the output terminal, otherwise can cause the output circuit breakdown.
- In order to protect the servo driver from noise interference that can cause malfunction, please use an insulation transformer and noise filter on the power lines.
- Wiring the power lines (power supply line, main circuit lines, etc.) at a distance above 30cm from the control signal wires, do not lay them in one conduit.
- Install a non-fuse circuit breaker that can shut off the external power supply immediately for in case of the servo driver fault.

2.1.3 Electric wire specifications

Connect terminal	Symbol	Wire specification
Main power supply	L1、L2、L3	1.5~2.5mm ²
Control power supply	L1C、L2C	0.75~1.0mm ²
Servomotor	U、V、W	1.5~2.5mm ²
Ground	⊕	1.5~2.5mm ²
Control signals	X1	≥0.14mm ² (AWG26), shielded
Encoder signals	X2	≥0.14mm ² (AWG26), shielded

Must use a twisted pair wire cable for the encoder signal wiring. If the encoder signal cable is too long (>20m), in which the encoder power supply can be insufficient, may use multi-wire or thick wire for the power supply wiring.

2.1.4 Servo motor and AC power supply wiring diagrams

The power supply for the servo driver is a three-phase AC 220V which generally come from three-phase AC380V power supply through a transformer. In peculiar circumstance, the small servomotor, which is less than 750W, can use single-phase AC220V (L1 and L2 terminals connect to single-phase power supply. Leave L3 terminal alone).

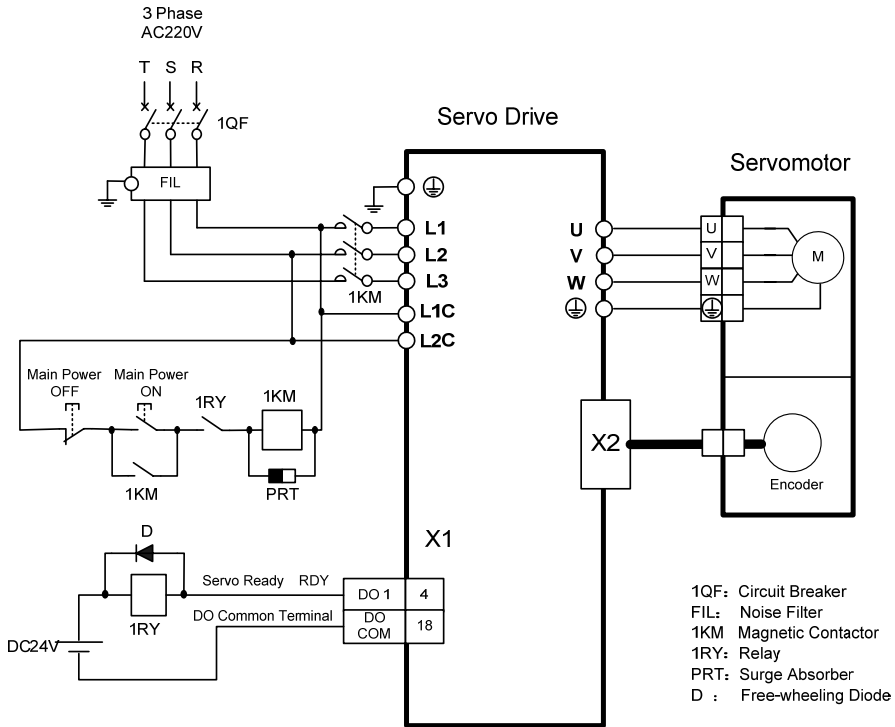

2.1.5 Main circuit terminal explanation

Terminal name	Symbol	Detailed explanation
Main power supply	L1、L2、L3	Connect to external AC power supply 3 phase 220VAC -15%~+10% 50/60Hz
Control power supply	L1C、L2C	Connect to external AC power supply 1 phase 220VAC -15%~+10% 50/60Hz
Servomotor	U	U phase output to servomotor
	V	V phase output to servomotor
	W	W phase output to servomotor
Ground	⊕	Ground terminal of servomotor
	⊕	Ground terminal of servo driver

2.2 X1 terminals for control signals

The X1 connector DB25 plug provides the signals interfaced with the host-controller. The signal includes:

- Five programmable inputs;
- Three programmable outputs;
- Analog command inputs;
- Pulse command inputs;
- Encoder signal outputs.

2.2.1 X1 terminal connector

The X1 connector plug uses DB25 male head, the contour and pin disposition charts are as the followings:

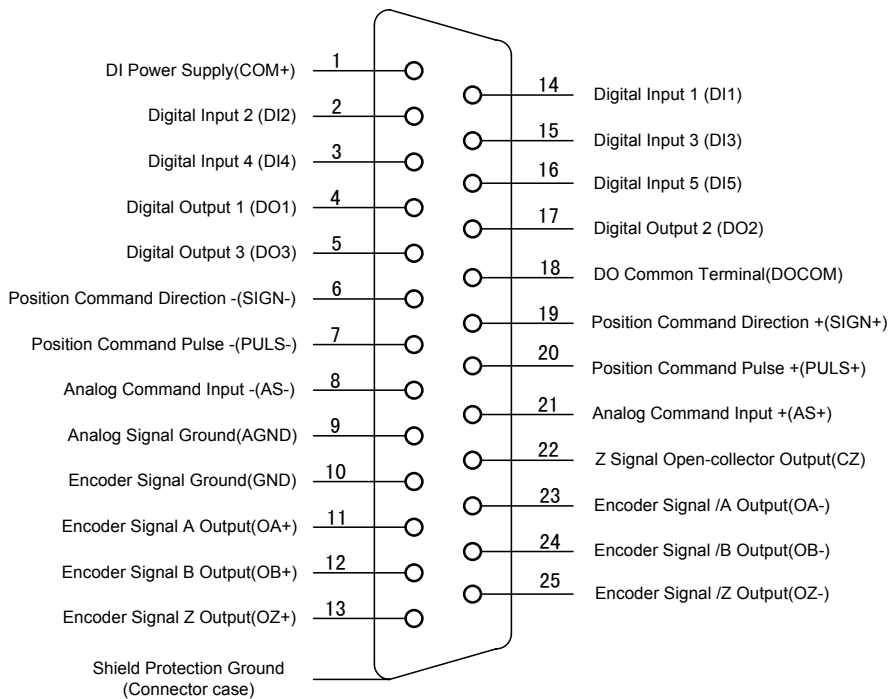

Servo Drive X1 Connector

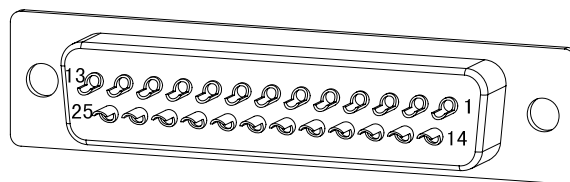

Connector X1 Soldering Lug Disposition

2.2.2 X1 terminal signal explanation

Name of signals		Pin number	Functions	Connector
Digital inputs	DI1	14	Photo isolation input;	C1
	DI2	2	Function is programmable;	
	DI3	15	Defines by parameter P100 to	
	DI4	3	P104.	
	DI5	16		
	COM+	1	DI power supply (DC12V~24V).	
Digital output	DO1	4	Photo isolation output;	C2
	DO2	17	Maximum output: 50mA/25V;	
	DO3	5	Function is programmable;	
			Defines by parameter P130~P132.	
	DOCOM	18	DO common terminal	
Position command pulse	PULS+	20	High speed photo isolation input;	C3
	PULS-	7	Working mode set by parameter	
	SIGN+	19	P035:	
	SIGN-	6	<ul style="list-style-type: none"> ● Pulse + Mark; ● Positive/Reverse pulse; ● Orthogonal pulse. 	
Analog command inputs	AS+	21	Speed/Torque analog quantity	C4
	AS-	8	input; The range is -10V to + 10V. <ul style="list-style-type: none"> ● DO NOT USE, please do not wire 	
	AGND	9	Analog Ground.	
Output signals of encoder	OA+	11	Outputs of differential driver (Line Driver) after the frequency division of encoder signal.	C5
	OA-	23		
	OB+	12		
	OB-	24		
	OZ+	13		
	OZ-	25		
	CZ	22	Open collector output of Z signal.	C6
	GND	10	Encoder signal ground.	
Shielded cable ground protection	Metal case of connector		Shielded wire for connection with shielded cable.	

2.2.3 X1 terminal interface type

The followings introduce the X1 various interface circuits and the wiring ways with the host-controller.

1. Digital input interfaces (C1)

For carrying on a control, the digital input interface circuit can be constructed by switch, relay, open-collector triode, and photo-coupler and so on. To avoid contacting problem the relay must be chosen with low current operation. External voltage is in the range of DC12V~24V.

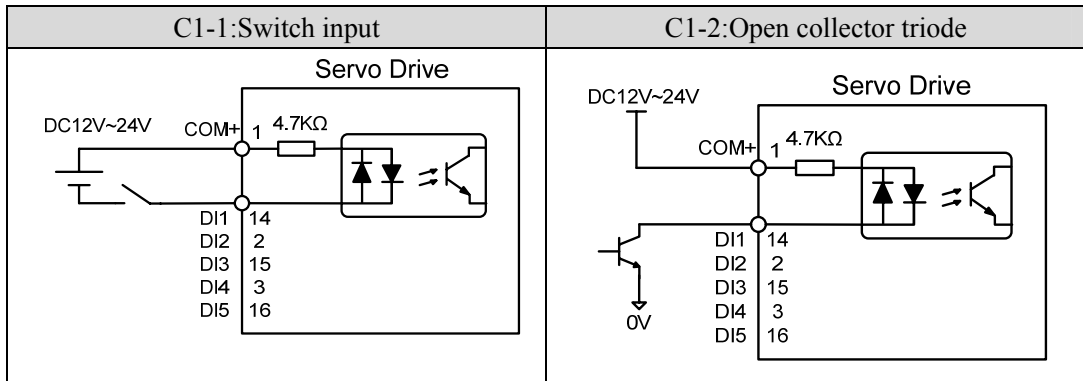

2. Digital output interfaces (C2)

The digital outputs use Darlington photo-coupler. It can be connected with relay, photo-coupler. Matters of note are:

- Inverting the polarity of DC power source, which is provided by the user, can cause the servo driver damage.
- The maximum voltage of external DC power supply is 25V, the maximum output current is 50mA, and the total current for three channels is not in excess of 100mA.
- When using relay like inductive loads, a free-wheel diode must be connected with the inductive load in parallel. If the diode connects in wrong direction can cause damage to the output circuit.
- Owing to the low level of output is approximately 1V and cannot satisfy the TTL low-level request, therefore cannot directly connect with the TTL circuit.

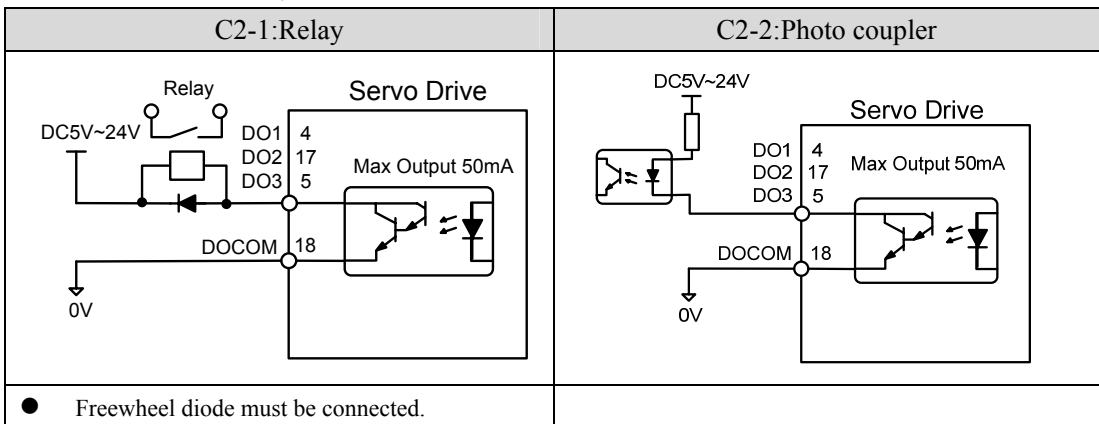

3. Position command pulse interfaces (C3)

There are both differential and single end connections. The differential connection is recommended and the twisted pair wire is used suitably. The drive current is in the range of 8 to 15mA. The operation mode is set by parameter P035: Pulse + Direction, CCW/ CW pulse, A phase + B phase (orthogonal pulse).

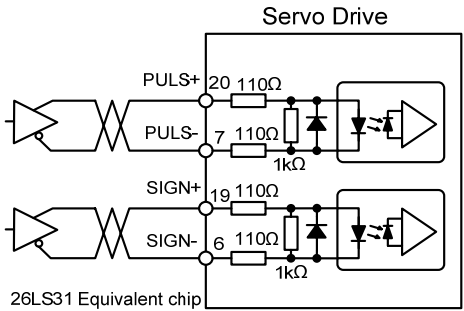
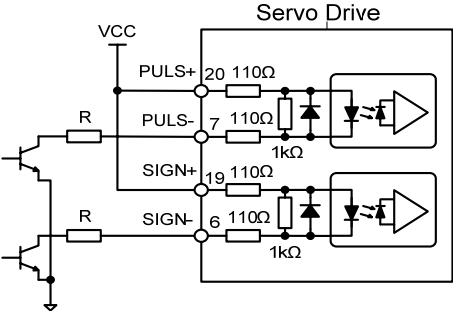
C3-1: Differential drive	C3-2: Single end drive								
 <p style="text-align: center;">Servo Drive</p> <p>26LS31 Equivalent chip</p>	 <p style="text-align: center;">Servo Drive</p>								
<ul style="list-style-type: none"> ● Maximum pulse frequency is 500kHz(kpps); ● This connection is recommended in order to avoid interference. 	<ul style="list-style-type: none"> ● Maximum pulse frequency is 200kHz(kpps); ● Resistance value of R is recommended. <table border="1" data-bbox="786 799 1103 970"> <thead> <tr> <th>VCC</th> <th>R</th> </tr> </thead> <tbody> <tr> <td>5V</td> <td>82Ω~120Ω</td> </tr> <tr> <td>12V</td> <td>510Ω~820Ω</td> </tr> <tr> <td>24V</td> <td>1.5kΩ~2kΩ</td> </tr> </tbody> </table>	VCC	R	5V	82Ω~120Ω	12V	510Ω~820Ω	24V	1.5kΩ~2kΩ
VCC	R								
5V	82Ω~120Ω								
12V	510Ω~820Ω								
24V	1.5kΩ~2kΩ								

4. Line driver outputs of the encoder signals (C5)

The signal divided from the encoder signal is transferred to the host-controller through the line driver.

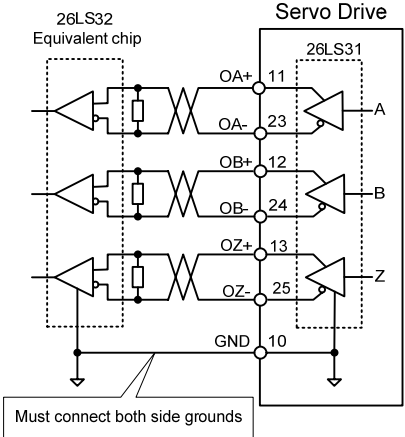
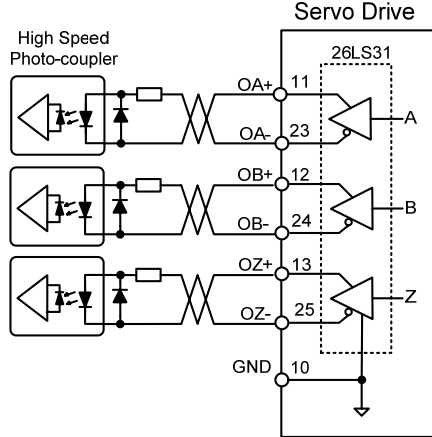
C5-1: Long line receiver	C5-2: Photo coupler receiver
	
<ul style="list-style-type: none"> On the host controller uses AM26LS32(or equivalent) to make the receiver, must connect the terminal resistance, the value is $220\Omega \sim 470\Omega$; Encoder signal (GND) of servo driver must connect with the ground terminal on host controller. 	<ul style="list-style-type: none"> On host controller use high-speed photo coupler (e.g. 6N137); Current limiting resistor is about 220Ω.

5. Open-collector output of encoder Z signal (C6)

The Z signal of the encoder is transferred to the host-controller through the open-collector circuit. Because the width of the Z pulse is narrow, please use a high-speed photo-coupler to receive it.

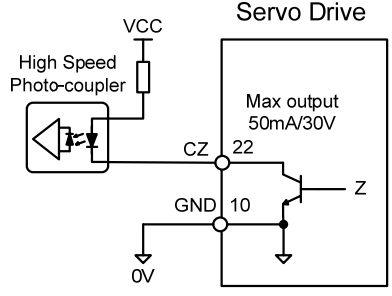
C6: Open collector output of encoder Z signal

<ul style="list-style-type: none"> 30V is the maximum voltage of external power supply; 50mA is the maximum current output.

2.2.4 Digital input definition

Every digital input interface is programmable, it can act different function by setting the corresponding parameter. The manufacturer sets it as the default value, users may need to modify.

Parameter	Name	Range	Default value	Unit	Usage
P100	Function of digital input DI1	-21~21	1		ALL
P101	Function of digital input DI2	-21~21	2		ALL
P102	Function of digital input DI3	-21~21	3		ALL
P103	Function of digital input DI4	-21~21	4		ALL
P104	Function of digital input DI5	-21~21	20		ALL

The absolute value of the parameter expresses functions; the symbolic expresses the logic, positive number expresses positive logic and the negative number express the negative logic(ON is effective, OFF is invalid):

Parameter	DI input signal	DI Result
Positive number	Turn off	OFF
	Turn on	ON
Negative number	Turn off	ON
	Turn on	OFF

DI function table:

Ordinal	Symbol	DI Function
0	NULL	Not have function
1	SON	Servo enable
2	ARST	Clear alarm
3	CCWL	CCW drive inhibition
4	CWL	CW drive inhibition
5	TCCW	CCW torque limitation
6	TCW	CW torque limitation
15	EMG	Emergency stop
18	GEAR1	Electronic gear switching 1
19	GEAR2	Electronic gear switching 2
20	CLR	Clear position deviation
21	INH	Pulse input inhibition

2.2.5 Digital output definition

Every digital output interface is programmable, it can act different function by setting the corresponding parameter. The manufacturer sets it as the default value, users may need to modify.

Parameter	Name	Range	Default value	Unit	Usage
P130	Function of digital output DO1	-11~11	2		ALL
P131	Function of digital output DO2	-11~11	3		ALL
P132	Function of digital output DO3	-11~11	8		ALL

The absolute value of the parameter expresses functions; the symbolic expresses the logic. '0' is forcing OFF, '1' is forcing ON. The symbol indicates the output logic, the positive number expresses the positive logic and the negative number expresses the negative logic:

Parameter value	Function	DO output signal
Positive number	ON	Turn on
	OFF	Turn off
Negative number	ON	Turn off
	OFF	Turn on

DO function table:

Ordinal	Symbol	DO Function
0	OFF	Always invalid
1	ON	Always valid
2	RDY	Servo ready
3	ALM	Alarm
5	COIN	Positioning complete
6	ASP	Arrival speed
8	BRK	Electromagnetic brake
11	TRQL	Torque under limitation

2.3 X2 encoder signal terminals

2.3.1 X2 terminal connector

The encoder signal connector X2 connects with the servomotor encoder. A three row of DB15 plugs (the VGA plug) is used. The contour and pin disposition charts are:

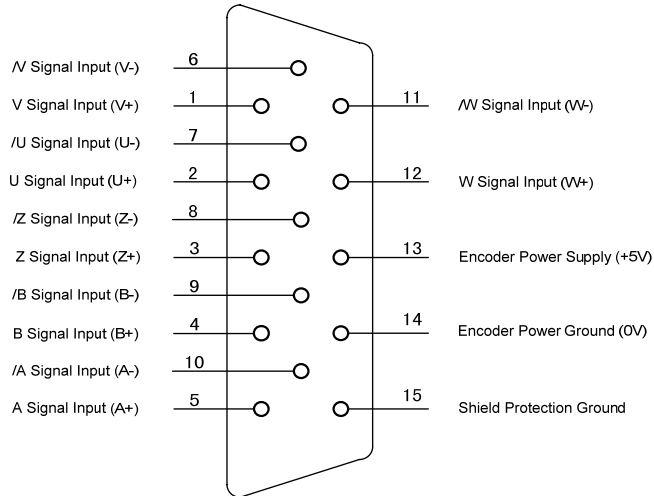

Servo Drive X2 Connector
(Standard Encoder)

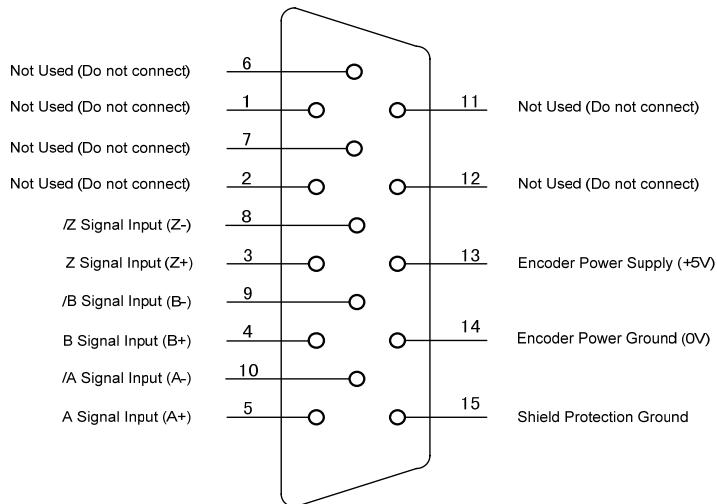

Servo Drive X2 Connector
(Wireless Encoder)

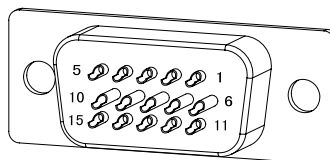

Connector X2 Soldering Lug Disposition

2.3.2 X2 terminal signal explanation

Signal name of encoder	Pin number	Colour of wire		Functions	
		Standard (16core) [note1]	Wire saving (10core) [note2]		
Power supply	5V	13	Red+Red /White	Red+Red /White	Use 5VDC power supply (provided by servo driver).If the cable is longer than 20m, in order to prevent encoder from voltage drop down, it is better to use multi wire or thick wire for power line and ground line.
	0V	14	Black+Black /White	Black+Black /White	
A phase input	A+	5	Brown	Brown	Connect with A phase output of encoder.
	A-	10	Brown/White	Brown/White	
B phase input	B+	4	Yellow	Yellow	Connect with B phase output of encoder.
	B-	9	Yellow /White	Yellow /White	
Z phase input	Z+	3	Green	Green	Connect with Z phase output of encoder.
	Z-	8	Green/White	Green/White	
U phase input	U+	2	Purple	/	Connect with U phase output of encoder. Not connect for wire saving.
	U-	7	Purple /White		
V phase input	V+	1	Blue	/	Connect with V phase output of encoder. Not connect for wire saving.
	V-	6	Blue/White		
W phase input	W+	12	Orange	/	Connect with W phase output of encoder. Not connect for wire saving.
	W-	11	Orange /White		
Shield ground	FG	15	Bare wire	Bare wire	Connect with cable shield wire.

Note: The optional extras provided by maxsine:

1. 16 core cable for the type of 16FMB15.
2. 10 core cable for the type of 10FBM15X (for using in the 80 frame of servomotor) and of 10FBM15 (for using in the 110 and above frame of servomotor).

2.4 Standard wiring diagram

2.4.1 Wiring diagram for position control

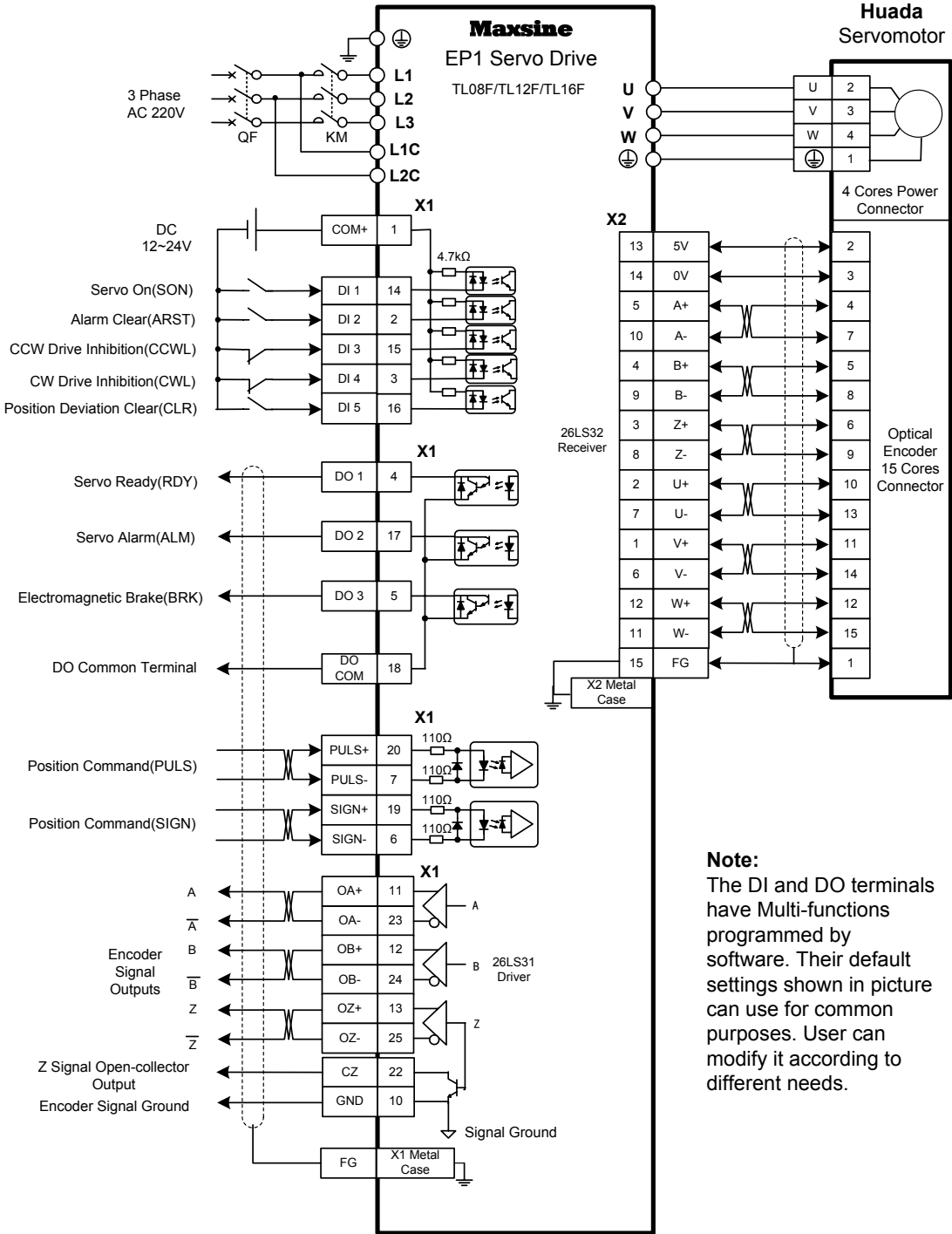

Chapter 3 Front panel operation

3.1 Explanation of the front panel of servo driver

3.1.1 Front panel compositions

The front panel consists of the display (5-digit, 7-segment LED) and four switching buttons (▲, ▼, ◀, and Enter). It displays monitor status, parameters and changes the parameter setting value and so on. The main menu is in cascade sequence mode and executes in layer.

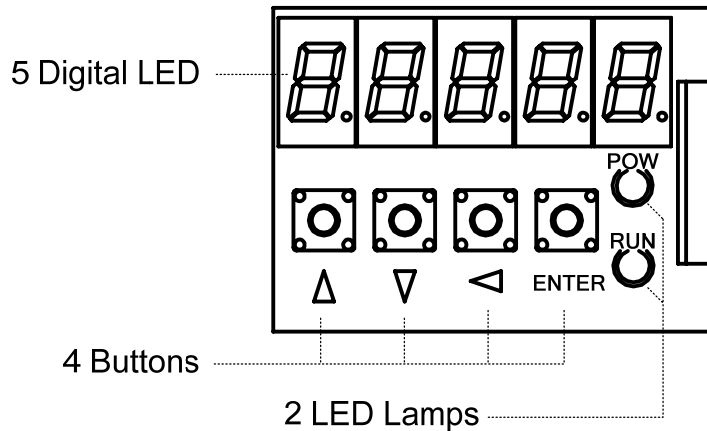

3.1.2 Front panel explanations

Symbol	Name	Functions
POW	Main power lamp	Lit: Main power supply already turn on; Go out: Main power supply did not turn on.
RUN	Running lamp	Lit: Servomotor is active; Go out: Servomotor is not active.
▲	Increasing button	Increase sequence number or value; Press down and hold to repeat increasing.
▼	Decreasing button	Decrease sequence number or value; Press down and hold to repeat decreasing.
◀	Exit button	Menu exit; cancel the operation.
Enter	Confirm button	Menu entered; the operation confirmed.

3.1.3 Data display

A number is shown by five digital displays; a minus symbol in front of the value represents a negative value; the lit decimal points in all the digits indicate a negative 5-digit value. Some displays have a prefix character. If the value is full-scale, then the prefix character can be omitted.

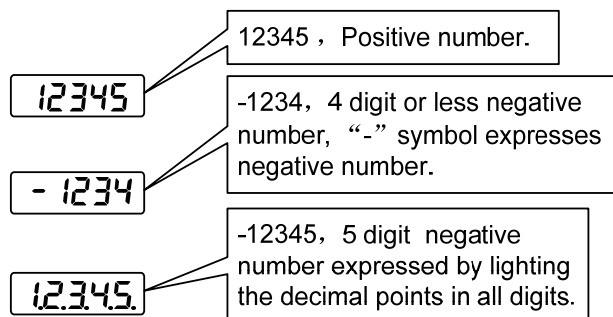



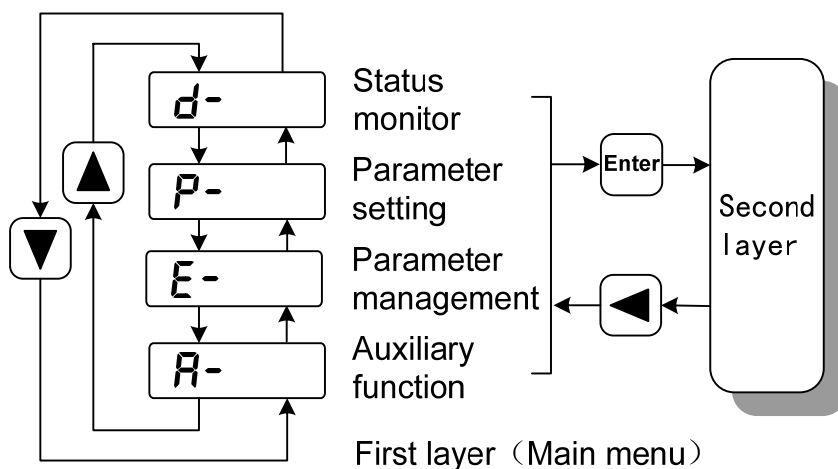

3.2 Main menu

The first layer is the main menu and has four operating modes. Pressing **▲** or **▼** button changes the operation mode. Pressing the **Enter** button enters the second layer and then executes a concrete operation. Pressing **◀** button returns to the main menu from the second layer.



3.3 Status monitor

Choose status monitor "d-" under the main menu. Pressing the  button enters the monitor mode. There are many kinds of monitor's project; Use  and  button to select the needing project. Pressing the  button again enters the concrete status display.

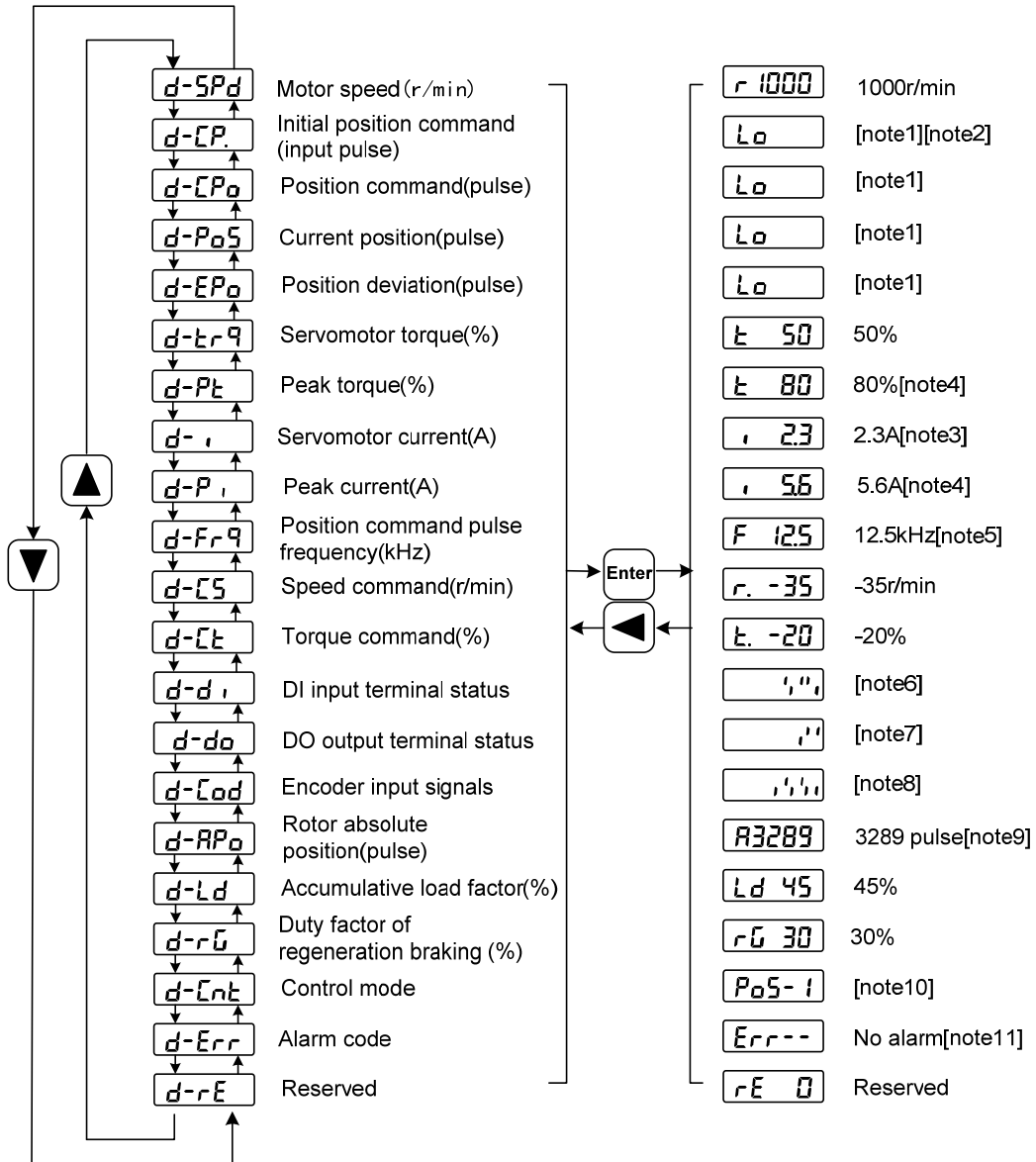

1. 32 binary bits value display [note1]

32 binary bits value translates into a decimal value that is in the range of -2147483648~147483647. It is divided into the low portion and the top portion. Use '▲' and '▼' button to select the needing portion through the menu. By the following formula, the complete value can be obtained.

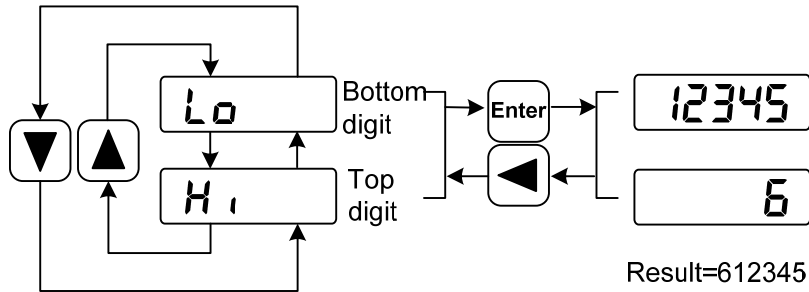

$$32\text{bit number} = \text{top digit number} \times 100000 + \text{bottom digit number}$$

2. Pulse unit [note2]

The original position command pulse is the input pulse count that has not transformed through the electronic gear. The pulse count unit for other parts is the same with the encoder pulse unit. Take a 2500 lines encoder as the example.

$$\begin{aligned} \text{Encoder pulse unit} &= \text{encoder resolution} \\ &= 4 \times \text{encoder line} \\ &= 4 \times 2500(\text{pulse / rev}) \\ &= 10000(\text{pulse / rev}) \end{aligned}$$

3. Motor current [note3]

The servomotor current is Irms.

4. Peak torque and peak current [note4]

The maximum torque and maximum Irms of the servomotor in previous 10-second duration is defined as the peak value.

5. Position command pulse frequency [note5]

The frequency of position command pulse is the actual pulse frequency before the electronic gear. The positive number is shown as positive direction and the negative number as reverse direction.

6. Input terminals DI [note6]

A vertical segment of LED shows an input status. The lit top vertical segment shows the DI input to be “ON” and the lit bottom vertical segment to be “OFF”.

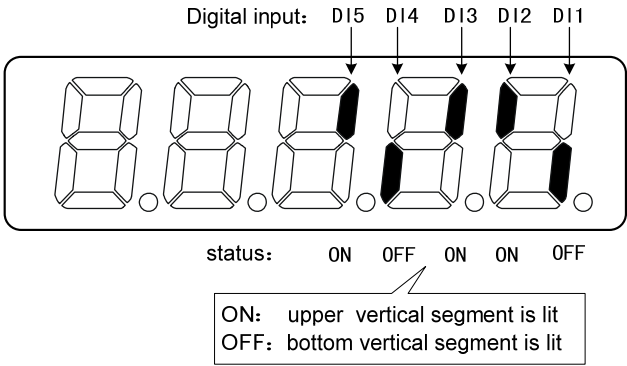

7. Output terminals DO [note7]

A vertical segment of LED shows an output status. The lit top vertical segment shows the DO output to be “ON” and the lit bottom vertical segment to be “OFF”.

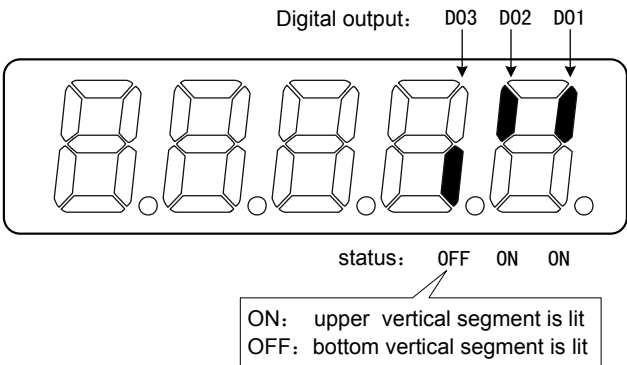

8. Input signals from encoder [note8]

A vertical segment of LED shows an input status. The lit top vertical segment shows a HIGH-level signal and the lit bottom vertical segment a LOW-level signal.

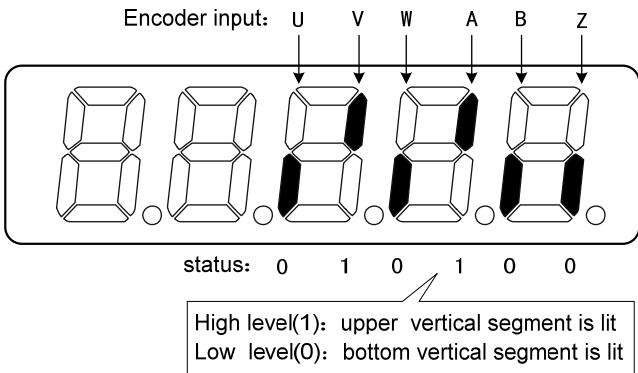

9. Absolute position of rotor [note9]

The rotor position is relative to the stator in one revolution per cycle. Use the encoder pulse unit and take the encoder Z pulse as the zero point. Take a 2500 lines encoder as the example. The position of the rotor is in the range of 0~9999 and is zero when Z pulse appears.

10. Control mode [note10]

The first three characters show the control mode, the final character shows gain group.

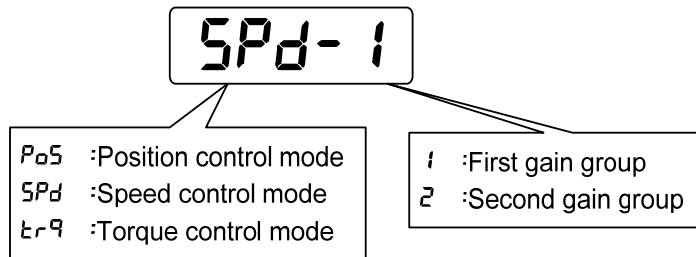

11. Alarm code [note11]

The "Err" followed by two minus symbols indicates no alarm and by digital number indicates an error code number that is flickering. When alarm appears, the error code number displays automatically on the front panel LED. During the error status, the monitor mode can be changed to other mode by pressing buttons, but the decimal point of the last LED is still flickering and shows existence of an alarm.

Err--







No alarm











Err 9

flickering 9 number alarm

3.4 Parameters setting

The parameter number expression uses a parameter section name combined with a parameter name. The three figures are the section name and two figures and one figure are the parameter name. Take P102 parameter as an example, '1' is the section name and '02' the parameter name. "P-102" displays on the front panel LED.

Choose the parameter mode under the main menu "P- ". Pressing the  button enters the parameter-setting mode. First use  or  button to select the parameter section name and then pressing  button enters the parameter name selection. Again, use  or  button to select the parameter name and then pressing  button shows the parameter value.



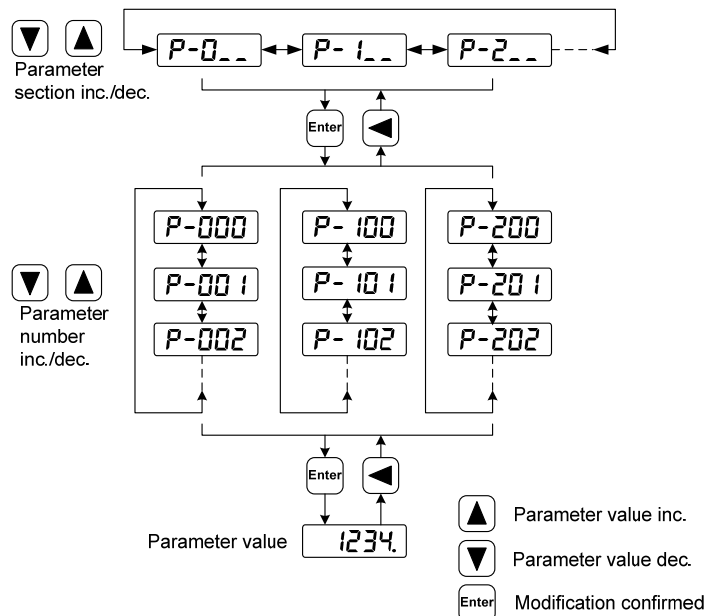

Use  or  button to alter a parameter value. Pressing  () button once to increase (decrease) the parameter value by one. Pressing down and hold the  () button, the parameter value can increase (decrease) continuously. When the parameter value is modified, the decimal point on the most right sides LED is lit. Press  button to confirm the parameter value to be effective, meanwhile the decimal point turns off. The modified parameter value is immediately active to influence on the control action (but some parameters needs to preserve firstly and then turn off and on the power supply). Hereafter pressing  button returns to the parameter number selection and can continue to modify a parameter. If the value is not satisfied, do not press the  button and can press  button to cancel it for resuming the original parameter value.

The modified parameter did not preserve in EEPROM. For permanent preservation, please refer to the parameter writing operation in the parameter management (3.5 sections). The parameter section name and the parameter name are not necessarily continual, but the parameter section name and the parameter name that are not in use will be jumped over and cannot be chosen.



3.5 Parameter management

Choose the parameter management mode under the main menu "E- ". Pressing the  button enters the parameter management mode. The operation is performed between parameter list and the EEPROM.

There are three operation modes. Use  or  button to select an operation mode and then pressing down and hold the  button at least three seconds to active the operation mode. After finished the operation and then pressing  button returns to the operation mode selection.

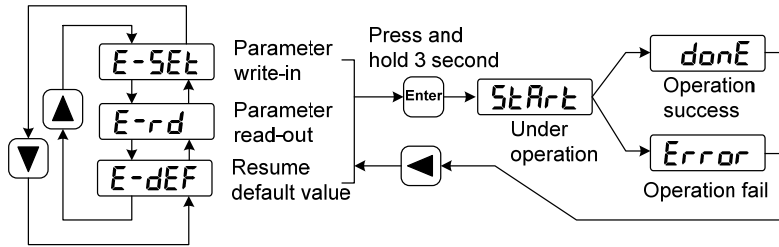

- **Write and save parameters**







This operation indicates that the parameter in parameter list will write to the EEPROM. When user has made change to a parameter, it only change the parameter value in parameter list, but for the next time when the power supply is on the parameter value will restore its original value. Making permanent change to a parameter value, it is the need to carry out the parameter write operation and write the parameter value to the EEPROM. Hereafter, when the power supply is on again will be able to use the new parameter value.

- **Read and fetch parameters**

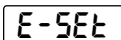

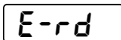

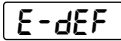
This operation indicates that all the parameters will be read from the EEPROM to the parameter list. This process will carry out automatically one time when power supply is on. At the beginning, the value of each parameter in the parameter list is the same as the parameter in the EEPROM. After making change to a parameter value, the value in the parameter list will also change. When the parameter value is not satisfied or comes to confusion, carries out the parameter read operation to read back the original parameter value from the EEPROM to the parameter list.

- **Resume default value**

This operation indicates that each default value of all the parameters will read from EEPROM and write to the parameter list and EEPROM. For the next time when power supply is on the default parameters will be used by now. When many parameters become confusion and cause abnormal operation, it is necessary to carry out this operation for resuming the default parameters. There are different default parameters for different servo driver model and the servomotor model. Therefore, before doing this operation the servo driver code (Parameter P001) and the servomotor code (Parameter P002) must be selected correctly.

	Parameter write-in	:	Parameter table		EEPROM
	Parameter read-out	:	Parameter table		EEPROM
	Resume default value:		Ex-factory default value		Parameter table、EEPROM

3.6 Auxiliary functions

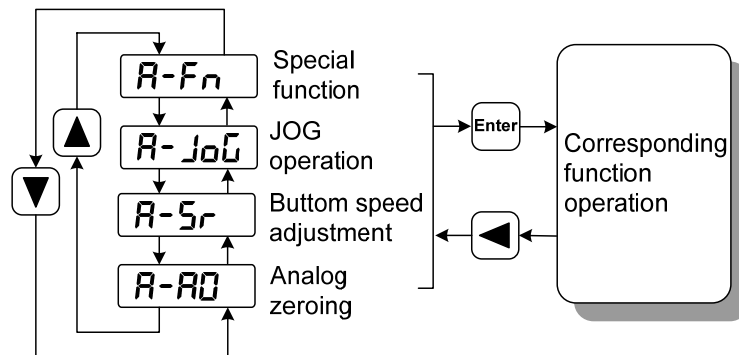

Choose the auxiliary function mode "R- " under the main menu. Pressing the  button enters the auxiliary function mode. Use  or  button to select an operation mode. Then pressing the  button again enters the corresponding function. After finished this operation pressing the  button returns to the operation mode selection.



3.6.1 Special functions



Use for manufacturer.

3.6.2 Jog function

Choose the JOG running "R- JoG" of the auxiliary function. Pressing the  button enters the JOG running mode. The "J " symbol is as a prompt of spot movement. The numerical value is the speed command provided by P076 parameter and the unit is r/min. Pressing down and hold the  button, the servomotor will rotate in counterclockwise direction with JOG speed. Loosen the pressed button, the servomotor stops rotation and keeps zero speed. Alternatively, pressing down and hold the  button, the servomotor will rotate in clockwise direction with JOG speed.



3.6.3 Speed adjustment by keyboards

Choose the adjustable speed "R-5r" of the auxiliary function. Pressing the  button enters the adjustable running mode. The "r." symbol is as a prompt of adjustable speed. The numerical value is the speed command provided by pressing  button (for increasing) or  button (for decreasing) and the unit is 0.1r/min. Following the speed command, the servomotor is in rotation. The rotation direction is dependent on the sign of the digits. The positive number indicates positive direction (CCW) and the negative number indicates reverse direction (CW).



3.6.4 Zeroing for analog quantity

No function of this device.

3.7 Resume the parameter default values

In case of the following situation, please use the function of resuming the default parameter (manufacture parameter):

- The parameter is adjusted chaotically, the system is unable the normal work.
- The servomotor is replaced by a different newly model.
- For any other reason, the servo driver code (parameter P001) does not match with the servomotor code (parameter P002).

The procedures for resuming the default parameter values are as the followings:

1. Inspection servo driver code (parameter P001) whether it is correct or not.
2. Inspection servomotor code (parameter P002) whether it is correct or not. If it is not correct, carries out following step, or jumps to 5 step.
3. Modify the password (parameter P000) by 360.
4. Modify the servomotor code (parameter P002) with newly servomotor code, referring to chapter 7.4 servomotor adaptive table.
5. Enter the parameter management, carries out one of following operations:

(1) Resume a part of the parameter default value

For resuming default parameters related to the servo driver and the servomotor and maintaining the other user parameters, carry out the parameter write operation in the parameter management. This operation is active only in that the password was 360 and the servomotor code was modified. In other situations, it only has the parameter write function.

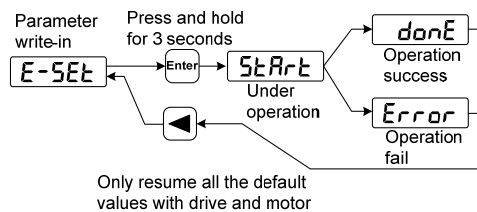

(2) Resume all of the parameter default value

Carry out to resume the default value in the parameter management, all the parameters including the parameter modified by the user become the default value.

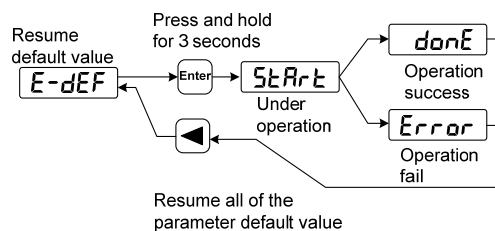

6. Turn off and on the power supply, then an operation can be performed again.

Chapter 4 Running

4.1 Trial running with no load

The goal of trial running is confirming the following items that are correct or not:

- The servo driver power supply wiring;
- The servomotor wiring;
- The encoder wiring;
- The running direction and the servomotor speed.

4.1.1 Wiring and inspection

Before turn on the power supply, confirms the servomotor:

- The servomotor has no loading on the shaft; decoupling from the machinery if already coupled.
- Because the servomotor has an impact during acceleration or deceleration, therefore the servomotor must be fixed.

Follow the wiring chart, inspects the following items before turning on the power supply:

- The wirings are correct or not. In particular, L1, L2, L3 wirings and U, V, W wirings corresponding to the servomotor U, V, W are correct or not.
- The input voltage is correct or not.
- The encoder cable connection is correct or not.

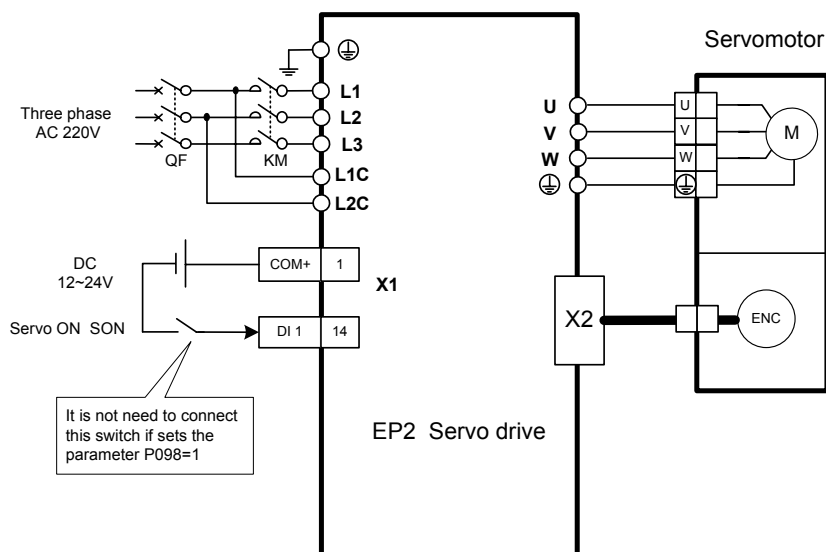

4.1.2 Trial running in JOG mode

1. Turn on power supply

Turn on the control power supply (while the main power supply temporarily turned off). The front panel display is lit. If any error appears, please inspect the wirings. Then turn on the main power supply, the POWER indicating LED is lit.



2. Parameter setting

Set parameters according to the following table:

Parameter	Name	Setting value	Default value	Parameter explanation
P004	Control mode	1	0	Set speed control
P025	Source of speed command	3	3	Set JOG source
P060	Acceleration time of speed command	suitable	0	Decrease acceleration impact
P061	Deceleration time of speed command	suitable	0	Decrease deceleration impact
P076	JOG running speed	100	100	JOG speed
P097	Neglect inhibition of servo driver	3	3	Neglect CCW inhibition (CCWL) and CW inhibition (CWL).
P098	Forced enable	1 or 0	0	Set '1' for forced enable; Set '0' for external enable.
P100	Digital input DI1 function	1	1	Set DI1 for servo enable (SON)

3. Operation

Confirming that there is no alarm and any unusual situation, turn on the servo enable (SON), the RUN indicating LED lit and the servomotor is active at zero speed.

Choose the JOG running "JOG" in the auxiliary function. Pressing the  button enters the JOG running mode. The numerical value is the speed command provided by P076 parameter and the unit is r/min. Pressing down and hold the  button, the servomotor will rotate in counterclockwise direction with the JOG speed. Loosen the pressed button, the servomotor stops and keeps zero speed. Alternatively, pressing down and hold the  button, the servomotor will rotate in clockwise direction with the JOG speed.



4.1.3 Trial running in speed adjustment mode with keyboard

1. Turn on power supply

Turn on the control power supply (while the main power supply temporarily turned off). The front panel display is lit. If any error appears, please inspect the wirings. Then turn on the main power supply, the POWER indicating LED is lit.



2. Parameter setting

Set parameters according to the following table:

Parameter	Name	Setting value	Default value	Parameter explanation
P004	Control mode	1	0	Set speed control
P025	Source of speed command	4	3	Set BUTTON source
P097	Neglect inhibition of servo driver	3	3	Neglect CCW inhibition (CCWL) and CW inhibition (CWL).
P098	Forced enable	1 or 0	0	Set '1' for forced enable; Set '0' for external enable.
P100	Digital input DI1 function	1	1	Set DI1 for servo enable (SON)

3. Operation

Confirming that there is no alarm and unusual situation, turn on the servo enable (SON), the RUN indicating LED lit and the servomotor is active at zero speed.

Choose the adjustable speed "R-5r" in the auxiliary function. Pressing the  button enters the adjustable running mode. The numerical value is the speed command provided by pressing  button (for increasing) or  button (for decreasing) and the unit is 0.1r/min. Following the speed command, the servomotor is in rotation. The rotation direction is dependent on the sign of digits. The positive number indicates positive direction (CCW) and the negative number indicates reverse direction (CW).



4.2 Position control mode

The position control applies in systems that need to locate precisely, such as numerical control machine tool, textile machinery and so on. The position command is a pulse serial coming from the input terminals PULS, PULS-, SIGN and SIGN- .

4.2.1 Simple example for position control mode

This is a simple example of positioning control. The wiring diagram is as below.

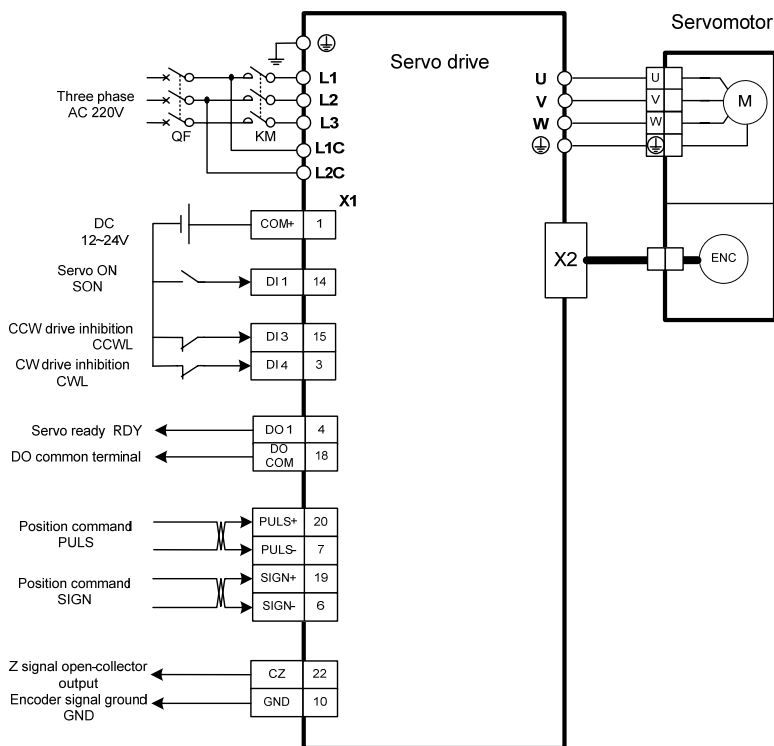

The parameter setting for the example:

Parameter	Name	Setting value	Default value	Parameter explanation
P004	Control mode	0	0	Set position control
P097	Neglect inhibition of servo driver	0	3	Use CCW inhibition (CCWL) and CW inhibition (CWL). If neglect, did not connect CCWL、CWL.
P100	Digital input DI1 function	1	1	Set DI1 for servo enable (SON)
P130	Digital output DO1 function	1	1	Set DO1 for servo is ready(RDY)

4.2.2 Position commands

1. Parameters related to position command

Parameter	Name	Range	Default value	Unit	Usage
P029	1 st numerator of electronic gear	1~32767	1		P
P030	Denominator numerator of electronic gear	1~32767	1		P
P031	2 nd numerator of electronic gear	1~32767	1		P
P032	3 rd numerator of electronic gear	1~32767	1		P
P033	4 th numerator of electronic gear	1~32767	1		P
P035	Input mode of command pulse	0~2	0		P
P036	Phase of input command pulse	0~1	0		P
P037	Signal logic of input command pulse	0~3	0		P
P038	Signal filter of input command pulse	0~31	7		P
P039	Filter mode of input command pulse	0~1	0		P
P040	Time-constant of exponential form filter for position command	0~1000	0	ms	P

2. Transmission path of command pulse

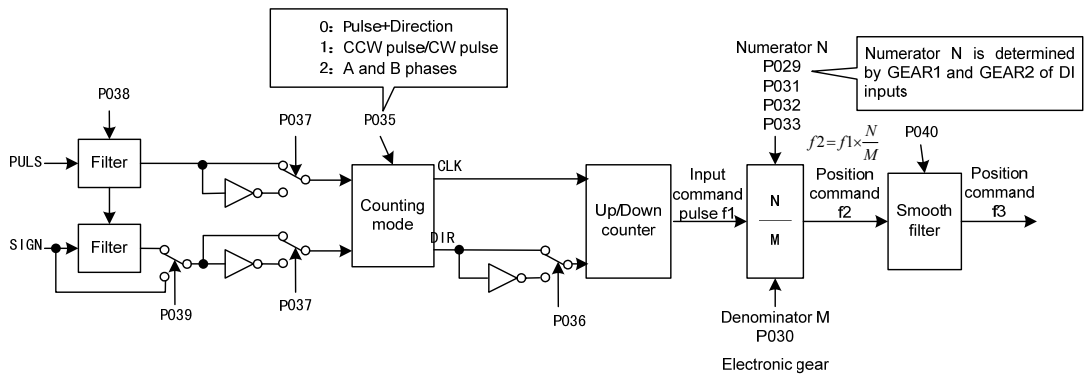

3. Input mode of command pulse

The command pulse input mode is dependent on the parameter P035. For adjusting the counting edge of a pulse, the parameter P037 sets the phases of the PULS and the SIGN signals. Parameter P036 uses in changing the counting direction.

Command pulse type	CCW	CW	Parameter P035
Pulse+ DIR			0
CCW pulse/ CW pulse			1
A phase+ B phase			2

Note: The arrow indicates the counting edge with P306=0 and P307=0.

4. Timing chart specifications of command pulse

Pulse waveform of position command	Parameter demand	
	Differential	Single end
<p style="text-align: center;">Pulse+DIR</p>	$t_{ck} > 2 \mu s$ $t_h > 1 \mu s$ $t_l > 1 \mu s$ $t_{rh} < 0.2 \mu s$ $t_{rl} < 0.2 \mu s$ $t_s > 1 \mu s$ $t_{qck} > 8 \mu s$	$t_{ck} > 5 \mu s$ $t_h >> 2.5 \mu s$ $t_l >> 2.5 \mu s$ $t_{rh} < 0.3 \mu s$ $t_{rl} < 0.3 \mu s$ $t_s > 2.5 \mu s$ $t_{qck} > 10 \mu s$
<p style="text-align: center;">CCW pulse/CW pulse</p>	$t_{qh} > 4 \mu s$ $t_{ql} > 4 \mu s$ $t_{qrh} < 0.2 \mu s$ $t_{qrl} < 0.2 \mu s$ $t_{qs} > 1 \mu s$	$t_{qh} > 5 \mu s$ $t_{ql} > 5 \mu s$ $t_{qrh} < 0.3 \mu s$ $t_{qrl} < 0.3 \mu s$ $t_{qs} > 2.5 \mu s$
<p style="text-align: center;">A phase+B phase</p>		

5. Signal filter

Numerical filters related to the parameter P038 will filter the input signal PULS and SIGN. The bigger the P308 value, the larger filter time-constant and the lower maximum repeated frequency of input pulse. If P038 is seven, the maximum repeated frequency of input pulse will reach 500 kHz (kpps).

If the positioning is not accurate, increase the parameter P038 in order to filter noise on the signal cable and to avoid counting error. The SIGN filter can close by parameter P039 setting.

6. Smooth filter

The parameter P040 carries on the smooth filter to the command frequency. It has the exponential form for acceleration and deceleration as showing in the following chart. The filter cannot lose any input pulse, but can delay its action time. When P040 is zero, the filter does not have any effect. The parameter value indicates the time in which the repeated frequency increases from 0 to 63.2% command frequency.

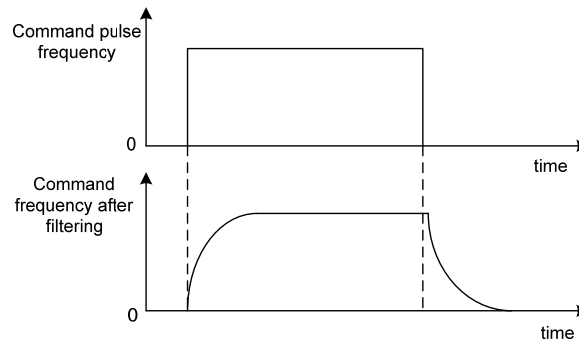

The filter makes the input repeated frequency smooth. This filter is used in the following situations: the host controller is without acceleration and deceleration function; the electronic gear ratio is quite big; the command frequency is lower.

4.2.3 Electronic gear for input commands

Through the electronic gear user can define that one input command pulse will cause an adjustable movement of mechanical device. Therefore, the host controller does not have to consider that the gear ratio in the mechanical system and the encoder line number of the servomotor. The electronic gear variable is illustrated in the following table.

Variable	Explanation	Value of this driver
C	Lines of encoder	2500
P_t	Resolution of encoder (pulse/rev)	$=4 \times C$ $=4 \times 2500$ $=10000(\text{pulse/rev})$
R	Ratio of reducer	$R=B/A$, here A : turn number of servomotor B : turn number of load shaft
ΔP	One command pulse travel equivalent	
P_c	Command pulse numbers for one turn of the load shaft	
$Pitch$	Pitch of ball bearing screw (mm)	
D	Diameter of rolling cylinder (mm)	

Calculating formula:

$$\text{Electronic gear ratio} \left(\frac{N}{M} \right) = \frac{\text{Resolution in one turn of encoder}(P_t)}{\text{Command pulse number in one turn of load shaft}(P_c) \times \text{reducer ratio}(R)}$$

Here,

$$\text{Command pulse number in one turn of load shaft } (P_c) = \frac{\text{Movement quantity in one turn of load shaft}}{\text{Movement quantity in one command pulse}}$$

The calculated result will be abbreviated and make the numerator and the denominator smaller or equal to 32767 integer values. At last, the result must be in the range of $1/50 < N/M < 200$ and write to the parameter list.

1. Electronic gear is used for ball screw drive

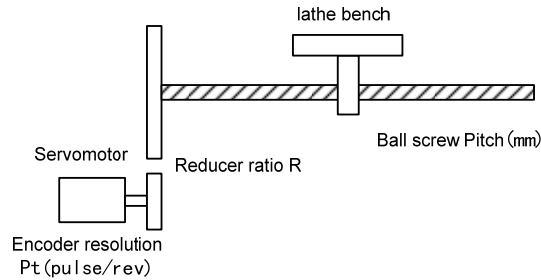

The ball bearing screw load has

$$\text{Electronic gear ratio} \left(\frac{N}{M} \right) = \frac{P_t}{P_c \times R}$$

Here,

$$P_c = \frac{\text{Pitch}}{\Delta P}$$

For example:

Known the encoder line number $C=2500$ line, the reducer gear ratio $1/1$, pitches $\text{Pitch}=8\text{mm}$, a pulse travel equivalent $\Delta P=0.001\text{mm}$. Calculate the electronic gear ratio.

Calculation step:

- Calculate the resolution of the encoder (P_t)

$$P_t = 4 \times C = 4 \times 2500 = 10000 (\text{pulse/rev})$$

- Calculate the command pulse numbers for one turn of the load shaft (ball-screw) (P_c)

$$P_c = \frac{\text{Pitch}}{\Delta P} = \frac{8\text{mm}}{0.001\text{mm}} = 8000$$

- Calculate the electronic gear ratio.

$$\text{Electronic gear ratio} \left(\frac{N}{M} \right) = \frac{P_t}{P_c \times R} = \frac{10000}{8000 \times (1/1)} = \frac{5}{4}$$

- Set parameters (By first numerator as an example)

Numerator $N=5$, denominator $M=4$, set $P029=5$ and $P030=4$.

2. Electronic gear is used for graduator drive

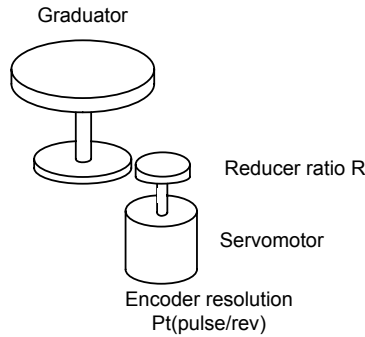

The graduator load has

$$\text{Electronic gear ratio} \left(\frac{N}{M} \right) = \frac{P_t}{P_c \times R}$$

Here,

$$P_c = \frac{360^\circ}{\Delta P}$$

For example:

Known the encoder line number $C=2500$ line, the reducer gear ratio $1/3$, a pulse travel equivalent $\Delta P=0.1^\circ$ Calculate the electronic gear ratio.

Calculation step:

- Calculate the resolution of the encoder (P_t)

$$P_t = 4 \times C = 4 \times 2500 = 10000(\text{pulse/rev})$$

- Calculate the command pulse numbers for one turn of the load shaft (P_c)

$$P_c = \frac{360^\circ}{\Delta P} = \frac{360^\circ}{0.1^\circ} = 3600$$

- Calculate the electronic gear ratio

$$\text{Electronic gear ratio} \left(\frac{N}{M} \right) = \frac{P_t}{P_c \times R} = \frac{10000}{3600 \times (1/3)} = \frac{30000}{3600} = \frac{25}{3}$$

- Set parameters (By first numerator as an example)

Numerator $N=25$, denominator $M=3$, set $P029=25$ and $P030=3$.

3. Electronic gear is used for conveyer belt drive

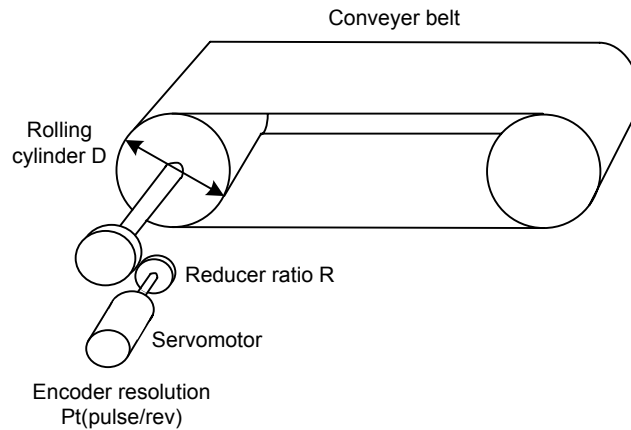

The conveyer belt load has

$$\text{Electronic gear ratio} \left(\frac{N}{M} \right) = \frac{P_t}{P_c \times R}$$

Here,

$$P_c = \frac{\pi D}{\Delta P}$$

For example:

Known the encoder line number $C=2500$ line, the reducer gear ratio $1/10$, the rolling cylinder diameter $D=200\text{mm}$, a pulse travel equivalent $\Delta P=0.001\text{mm}$, Calculate the electronic gear ratio.

Calculation step:

- Calculate the resolution of the encoder (P_t)

$$P_t = 4 \times C = 4 \times 2500 = 10000 (\text{pulse} / \text{rev})$$

- Calculate the command pulse numbers for one turn of the load shaft (P_c)

$$P_c = \frac{\pi D}{\Delta P} = \frac{3.14 \times 200}{0.01} = 62800$$

- Calculate the electronic gear ratio

$$\text{Electronic gear ratio} \left(\frac{N}{M} \right) = \frac{P_t}{P_c \times R} = \frac{10000}{62800 \times (1/10)} = \frac{100000}{62800} = \frac{2500}{157}$$

- Set parameters (By first numerator as an example)

Numerator $N=2500$, denominator $M=157$, set $P029=2500$ and $P030=157$.

4. The relation between the electronic gear ratio and the turn number of servomotor

The relation between the electronic gear ratio and the turn number of servomotor is:

$$\text{Servomotor turn number} = \frac{\text{pulse} \times N}{P_i \times M}$$

Among them, pulse is input pulse number. For example, the encoder line number C=2500 line, N=20, M=3, pulse=1000, the calculation is:

$$\text{Servomotor turn number} = \frac{1000 \times 20}{10000 \times 3} = \frac{2}{3} (\text{Turn})$$

5. The relation between the electronic gear ratio and the speed of servomotor

The relation between the electronic gear and the speed of servomotor is:

$$\text{Servomotor speed}(r / \text{min}) = \frac{f(\text{Hz}) \times 60 \times N}{P_i \times M}$$

Among them, f is the repeated frequency of the input pulse; unit is Hz (pps). For example, the encoder line number C=2500 line, N=3, M=1, f=100kHz (kpps), the calculation is:

$$\text{Servomotor speed}(r / \text{min}) = \frac{100 \times 10^3 \times 60 \times 3}{10000 \times 1} = 1800(r / \text{min})$$

6. Electronic gear ratio switching

Four groups of electronic gear numerator N are provided in the servo driver. The group can be changed online by signal of GEAR1 and GEAR2 from DI inputs. However, the denominator M is all the same.

DI signal[<i>note</i>]		Numerator of input electronic gear N	Denominator of input electronic gear M
GEAR2	GEAR1		
0	0	1 st numerator(parameterP029)	Denominator (parameterP030)
0	1	2 nd numerator(parameterP031)	
1	0	3 rd numerator(parameterP032)	
1	1	4 th numerator(parameterP033)	

Note: 0 indicates OFF; 1 indicates ON.

4.2.4 Gains related to position control mode

Parameter	Name	Range	Default value	Unit	Usage
P009	gain of position loop	1~1000	40	1/s	P
P021	Feed forward gain of position loop	0~100	0	%	P
P022	Time-constant of feed forward filter for position loop	0.20~50.00	1.00	ms	P

According to the inner loop adjusts first and then the outer loop, the speed loop is included in the position loop, therefore the rotation inertia ratio of load will be set first with suitable value. Then, the gain and the integral time-constant of the speed loop are adjusted. At last, the gain of the position loop is adjusted.

The following block diagram is the position regulator of the system. Increasing the gain of position loop can get higher position loop bandwidth, but it is limited by the speed loop bandwidth. Therefore, in order to increase the gain of the position loop must increase the bandwidth of speed loop first.

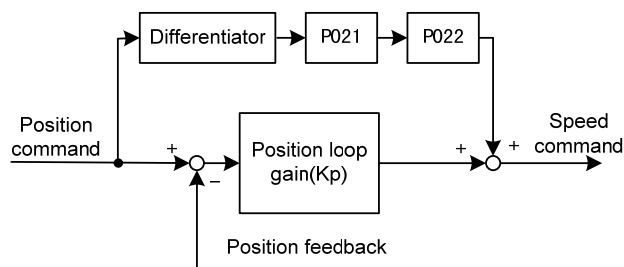

The feed forward can reduce the lagging of phase in the position loop; also reduce the position tracking error as well as shorter positioning time. The feed forward quantity increases, the position tracking error reduces, but can cause the system unstable and overshoot if the feed forward quantity is too large. If the electronic gear ratio is more than 10 it is also easy to make noise. For normal application, the parameter P021 is set as 0%. If higher response and lower tracking error are required, the P021 can be increased properly, but not in excess of 80%. Meanwhile it may need to adjust the filter time constant (parameter P022) of the feed forward branch.

4.3 Gain adjustment

The servo driver includes the current control loop, the speed control loop and the position control loop. The control diagram is as follows:

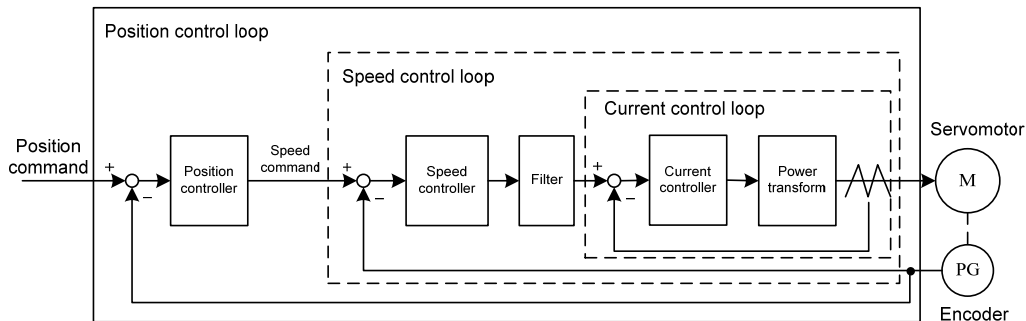

Theoretically, the inner control loop bandwidth must be higher than the outer loop; otherwise, the entire control system will be unstable and creates the vibration or worse response. Therefore, the relations of the bandwidth of the three control loops are as follows:

Bandwidth of the current loop > Bandwidth of the speed loop > Bandwidth of the of the position loop

Because the current control loop of the servo driver is already adjusted in an optimum condition, the only parameters of speed and position control loops have to be adjusted by the user.

4.3.1 Gain parameters

The parameters related to the gain are:

Parameter	Name	Range	Default value	Unit	Usage
P005	Gain of speed loop	1 ~ 3000	40	Hz	P,S
P006	Integral time constant of speed loop	1.0 ~ 1000.0	20.0	ms	P,S
P009	Gain of position loop	1 ~ 1000	40	1/s	P
P017	Ratio of load inertia	0.0 ~ 200.0	1.5	-fold	P,S

The definition of symbol as follows:

- K_v : The gain of speed loop;
- T_i : The integral time-constant of speed loop;
- K_p : The gain of position loop;
- G : The inertia ratio of load (P017);
- J_L : The load inertia referred to the rotor shaft;
- J_M : The rotor inertia of the servomotor.

1. The gain of speed loop K_v

The speed loop gain K_v directly determines the response bandwidth of the speed loop. Under the premise that there is no vibration in the mechanical system or noise, increases the speed loop gain, then the speed response can speed up, and is better to follow the speed command. However, it is easy to cause a mechanical resonance if the K_v is too large. The bandwidth of speed loop expresses as:

$$\text{Speed loop bandwidth (Hz)} = \frac{1+G}{1+J_L/J_M} \times K_v \text{ (Hz)}$$

If the setting inertia ratio of the load G is correct ($G=J_L/J_M$), then the bandwidth of the speed loop is equal to the speed loop gain K_v .

2. The integral time-constant of speed loop T_i

The integral item of speed loop has an effect to eliminate static error of speed, and has rapid reaction to a slight speed change. Under the premise that there is no vibration in the mechanical system or noise, reduces the integral time constant T_i of speed loop, then the stiffness of the system increases, and reduces the static error. If load inertia ratio is very big or a resonating factor exists in the mechanical system, and then must confirm that the integral time constant is big enough, otherwise the mechanical system will be easy to cause resonating. If the setting inertia ratio of the load G is correct ($G=J_L/J_M$), uses following formula to obtain the integral time constant T_i of the speed loop.

$$T_i \text{ (ms)} \geq \frac{4000}{2\pi \times K_v \text{ (Hz)}}$$

3. The gain of position loop K_p

The gain of the position loop directly determines the reaction rate of the position loop. Under the premise that there is no vibration in the mechanical system or noise, increases the position loop gain, then speeds up the reaction rate, reduces the position tracking error and the positioning time is shorter. However, it is easy to cause a mechanical vibration or over travel if the K_p is too large. The bandwidth of the position loop should be lower than the bandwidth of speed loop. In general:

$$\text{Position loop bandwidth (Hz)} \leq \frac{\text{Speed loop bandwidth (Hz)}}{4}$$

If the setting inertia ratio of the load G is correct ($G=J_L/J_M$), uses the following formula to obtain the gain K_p of the position loop:

$$K_p \text{ (1/s)} \leq 2\pi \times \frac{K_v \text{ (Hz)}}{4}$$

4.3.2 Procedure for gain adjustment

The bandwidth selections of the position and the speed loop depend on the machinery rigidity and the application situation. A leather belt conveyer has low rigidity and may set low bandwidth. Machinery with reducer and ball bearing screw has medium rigidity and may set medium bandwidth. Machinery with ball bearing screw or linear motor has higher rigidity and may set high bandwidth. If mechanical characteristics are unknown, may gradually increase the bandwidth until resonating, and then decreases the gain.

In the servo system, if changes a parameter, then other parameters also need to readjust. Therefore, do not change a parameter far from its original value. About the steps for changing the servo parameter, please observe the following principle generally:

Increase response	Decrease response, restrain vibration and overshoot
1. Increase gain of speed loop K_v	1. Decrease gain of position loop K_p
2. Decrease integral time constant of speed loop T_i	2. Increase integral time constant of speed loop T_i
3. Increase gain of position loop K_p	3. Decrease gain of speed loop K_v

Gain adjustment procedure for speed control loop

1. Set the load inertia ratio.
2. Set integral time constant of the speed loop with a relatively great value.
3. Under no vibration and unusual sound increase the gain of the speed loop, if vibration occurs then decrease the gain a bit.
4. Under no vibration and unusual sound, decrease the integral time constant of speed loop, if vibration occurs then increase the time constant a bit.
5. Because the mechanical system may have resonating factors and is unable to adjust for a bigger gain, then the desired response cannot obtain. Now, adjust the filter time constant (parameter P007) of torque, and then carry on above steps again enhancing responsiveness.

Gain adjustment procedure for position control loop

1. Set the load inertia ratio.
2. Set integral time constant of the speed loop with a relatively great value.
3. Under no vibration and unusual sound increase the gain of the speed loop, if vibration occurs then decrease the gain a bit.
4. Under no vibration and unusual sound, decrease the integral time constant of speed loop, if vibration occurs then increase the time constant a bit.
5. Increase the gain of position loop, if vibration occurs then decreases the gain a bit.
6. Because the mechanical system may have resonating factors and is unable to adjust for a bigger gain, then the desired response cannot obtain. Now, adjust the filter time constant (parameter P007) of torque, and then carry on above steps again enhancing responsiveness.
7. If need shorter positioning time and smaller position tracking error, can adjust the feed forward of the position loop. Please refer to 4.2.4 section.

4.4 Resonance suppressions

When the mechanical system has the resonance effect, it is possibly created by higher rigidity of the servo system and quicker response. It may improve if reduce the gain. The servo driver provides the low pass filter. Under unchanging the gain by using filters can achieve the effect of resonance suppression.

The parameters related to Resonating suppression as follows:

Parameter	Name	Range	Default value	Unit	Usage
P007	Time constant of filter for torque	0.10~50.00	2.50	ms	ALL

The low pass filter is active by default. The parameter P007 is used to setting the time constant of torque filter. The low pass filter has the very good weaken effect on high frequency and can suppress high frequency resonance and noise. For example, the machinery with ball bearing screw sometimes can have high frequency resonance if increasing the gain. Using low pass filter can get better effect, but the system response bandwidth and the phase allowance also reduced, the system may become unstable.

When the high frequency vibration caused by the servo driver, adjust the filter time-constant T_f of torque, possibly can eliminate the vibration. The smaller the value, the better control response achieves, but it is limited by mechanical condition. ; The bigger the value, the better suppressing effect achieves on high frequency vibration, but the phase allowance reduces and can cause the oscillation if the value is too big. If the load inertia ratio is set correctly G ($G=JL/JM$), must satisfy the following condition:

$$T_f(ms) \leq \frac{1000}{2\pi \times 2 \times K_v(Hz)}$$

4.5 Over-travel protections

The security function of over travel protection is refers that when the movement part of the machinery just exceed the design safe range of motion, the limit switch acts and forces the servomotor to stop. A schematic diagram showing the over travel protection as follows:

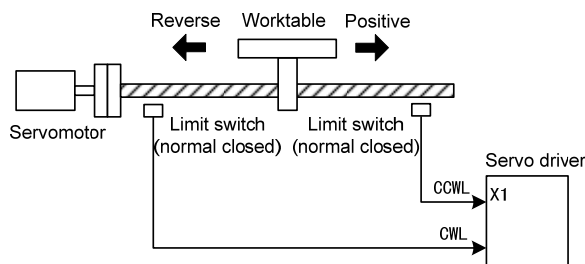

The limit switch suggested using normal closed type. It is close in the safety range and it is open in over travel range. The limit switch on the right connects to CCW forbid terminal (CCWL) and the limit switch on the left connects to CW forbid terminal (CWL).

This security function of over travel protection can be set for use or neglect by setting the parameter P097. The limit signal must be connected for the use, or do not need this signal in case of neglect.

The default value of P097 (for CCWL and CWL) is all neglects. Must modify parameter P097 if needs to use. Under the over travel condition, use the reverse command to withdraw back from the over travel condition.

P097	Motion inhibition in CW direction(CWL)	Motion inhibition in CCW direction(CCWL)
0	Use	Use
1	Use	Neglect
2	Neglect	Use
3(Default)	Neglect	Neglect

4.6 Torque limitations

In order to protect the machinery from over-load can carry on the limit to the output torque.

4.6.1 Parameters for torque limitations

The parameters related to torque limit:

Parameter	Name	Range	Default value	Unit	Usage
P065	Internal torque limit in CCW direction	0~300	300	%	ALL
P066	Internal torque limit in CW direction	-300~0	-300	%	ALL
P067	External torque limit in CCW direction	0~300	100	%	ALL
P068	External torque limit in CW direction	-300~0	-100	%	ALL
P069	Torque limit in trial running	0~300	100	%	ALL

4.7 Timing chart of operation

4.7.1 Timing chart when power supply switch on

- The control power supply L1C, L2C turns on before or at the same time when the main power supply L1, L2, and L3 turn on. If only the control power supply turn on, the servo ready signal (RDY) is OFF.
- After the main power supply turn on, at about 1.5 seconds later the servo ready signal is on (RDY), from now can accept the servo enable signal (SON). The servo driver examines that the SON is effective, and then the power circuit and the servomotor are active. The servomotor is in running status. If the SON is invalid or an alarm occurs, power circuit shut down and the servomotor is in free running state.

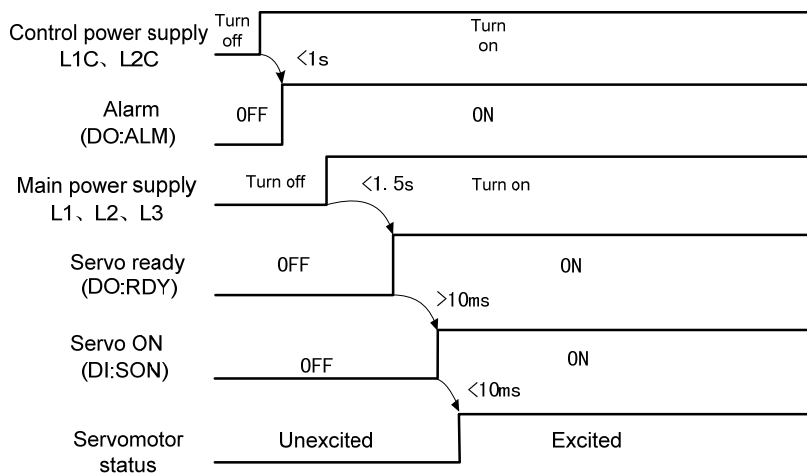

4.7.2 Alarm timing chart while servo-ON is executed

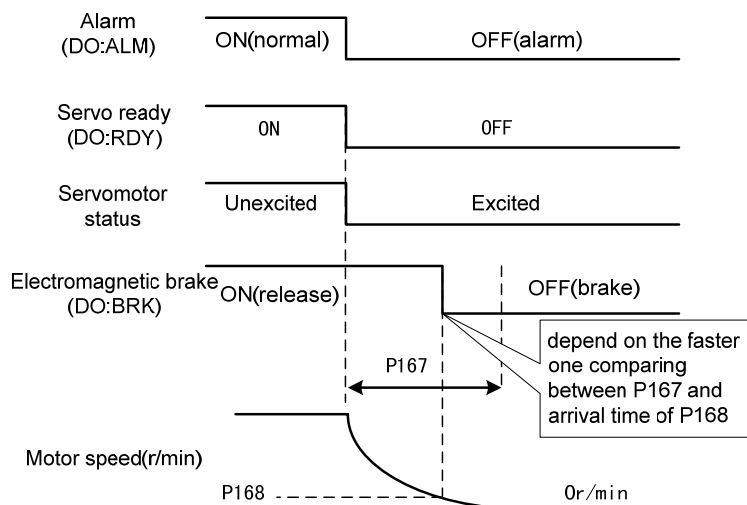

4.7.3 Action timing chart while servo-ON/OFF are executed during the servo motor is in standstill

When the speed of the servomotor is lower than parameter (P165), the action-timing chart is:

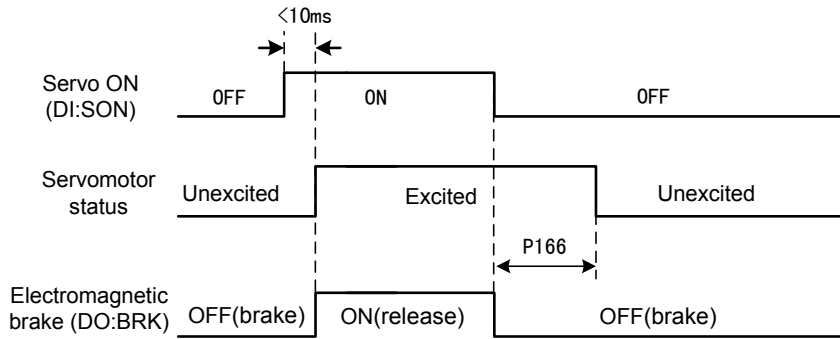

4.7.4 Action timing chart while servo-ON/OFF are executed during the servo motor is in motion

When the speed of the servomotor is higher than parameter (P165), the action-timing chart is:

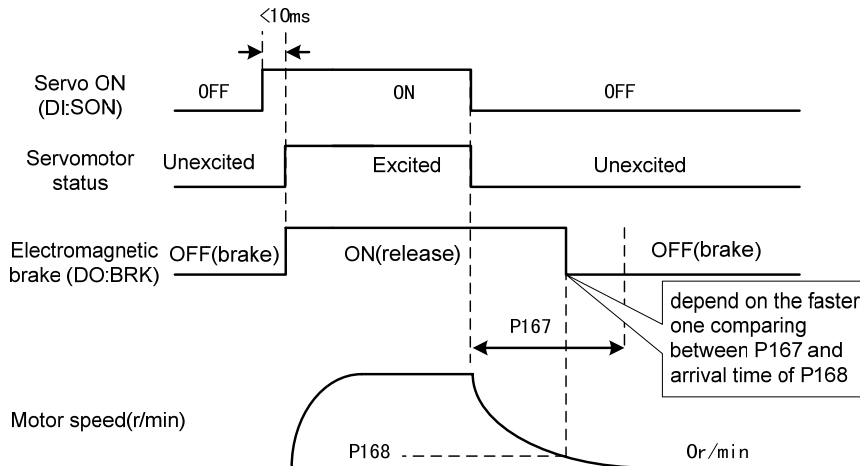

4.8 Electromagnetic holding brake

The electromagnetic brake (holding brake, lost power brake) is used in locking the vertical or the inclined worktable of machine tool, which connected with the servomotor. When the power supply lost or SON is OFF, prevent the worktable from fall and break. Realizes this function, must select and purchase the servomotor with electromagnetic brake. The brake only can use for holding the worktable and cannot use for decelerating and or stopping machine movement.

4.8.1 Parameters of electromagnetic holding brake

The parameters related to the electromagnetic brake:

Parameter	Name	Range	Default value	Unit	Usage
P165	Speed check point for servomotor is near standstill	0~1000	5	r/min	ALL
P166	Delay time for electromagnetic brake when servomotor is in standstill	0~2000	0	ms	ALL
P167	Waiting time for electromagnetic brake when servomotor is in motion	0~2000	500	ms	ALL
P168	Action speed for electromagnetic brake when servomotor is in motion	0~3000	100	r/min	ALL

4.8.2 Make use of electromagnetic holding brake

The chart below is the brake wiring diagram, the brake release signal BRK of the servo driver connect to the relay coil, the contact of relay connect brake coil and DC supply. The brake power supply has enough capacity provided by the user. Suggested installs the surge absorber to suppress surge voltage caused by switching off the relay. The diode also makes the surge absorber, but must pay attention to that the action of the brake has a little lagging.

Under the speed of the servomotor is smaller than parameter P165, if the SON becomes OFF. By now, the servomotor will continue to excitation for holding the position, after the period set by parameter P166 removes the excitation from the servomotor.

Under the servomotor is in motion (The speed is bigger than P165) if the SON becomes OFF, by now the excitation is removed from the servomotor, after delay period of time the brake becomes active. During the delay time, the servomotor decelerates from the high speed down to the low speed, and then the brake is active to avoid damaging the brake. The delay time is set by the parameter P167 or is the time that the speed of the servomotor decelerates to the speed set by parameter P168. The delay time will take the minimum value.

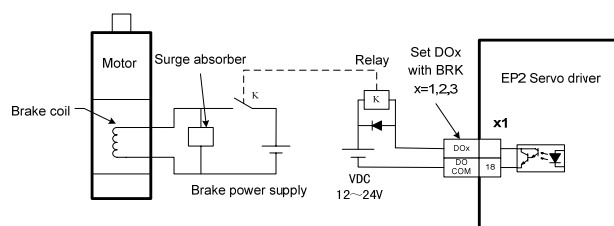

Remarks

Chapter 5 Parameters

5.1 Parameter table

The usage item in the table indicates the suitable control mode. “P” stands for the position control; “S” stands for the speed control; “T” stands for the torque control; “All” stands for the position, speed, and torque control. The “*” indicates default value that may be different.

5.1.1 Parameters of section 0

Parameter	Name	Range	Default value	Unit	Usage
P000	Password	0~9999	315		ALL
P001	Identity code of servo driver	*	*		ALL
P002	Identity code of servomotor	*	*		ALL
P003	Software edition	*	*		ALL
P004	Control mode	0~1	0		ALL
P005	Gain of speed loop	1~3000	40	Hz	P,S
P006	Integral time constant of speed loop	1.0~1000.0	20.0	ms	P,S
P007	Filter time constant of torque	0.10~50.00	2.50	ms	ALL
P009	Gain of position loop	1~1000	40	1/s	P
P017	Inertia ratio of load	0.0~200.0	1.5	-fold	P,S
P019	Time constant of filter for speed detection	0.50~50.00	2.50	ms	P,S
P021	Feed forward gain of position loop	0~100	0	%	P
P022	Time constant of feed forward filter for position loop	0.20~50.00	1.00	ms	P
P025	Sources of speed command	3~5	3		S
P029	First numerator of electronic gear for command pulse	1~32767	1		P
P030	Denominator of electronic gear for command pulse	1~32767	1		P
P031	Second numerator of electronic gear for command pulse	1~32767	1		P
P032	Third numerator of electronic gear for command pulse	1~32767	1		P

Chapter 5 Parameters

Parameter	Name	Range	Default value	Unit	Usage
P033	Fourth numerator of electronic gear for command pulse	1~32767	1		P
P035	Input mode of command pulse	0~2	0		P
P036	Input direction of command pulse	0~1	0		P
P037	Input signal logic of command pulse	0~3	0		P
P038	input signal filter of command pulse	0~21	7		P
P039	Input filter mode of command pulse	0~1	0		P
P040	Time-constant of exponential form filter for position command	0~1000	0	ms	P
P060	Acceleration time of speed command	0~30000	0	ms	S
P061	Deceleration time of speed command	0~30000	0	ms	S
P065	Internal torque limit in CCW direction	0~300	300	%	ALL
P066	Internal torque limit in CW direction	-300~0	-300	%	ALL
P067	External torque limit in CCW direction	0~300	100	%	ALL
P068	External torque limit in CW direction	-300~0	-100	%	ALL
P069	Torque limit in trial running	0~300	100	%	ALL
P070	Alarm level of torque overload in CCW direction	0~300	300	%	ALL
P071	Alarm level of torque overload in CW direction	-300~0	-300	%	ALL
P072	Detection time for torque overload alarm	0~10000	0	10ms	ALL
P075	Maximum speed limit	0~5000	3500	r/min	ALL
P076	JOG running speed	0~5000	100	r/min	S
P080	Position deviation limit	0.00~327.67	4.00	Circle	P
P096	Items of initial display	0~22	0		ALL
P097	Neglect inhibition of servo driver	0~3	3		ALL
P098	Forced enable	0~1	0		ALL

5.1.2 Parameters of section 1

Parameter	Name	Range	Default value	Unit	Usage
P100	Function of digital input DI1	-21~21	1		ALL
P101	Function of digital input DI2	-21~21	2		ALL
P102	Function of digital input DI3	-21~21	3		ALL
P103	Function of digital input DI4	-21~21	4		ALL
P104	Function of digital input DI5	-21~21	20		ALL
P110	Filter of digital input DI1	0.1~100.0	2.0	ms	ALL
P111	Filter of digital input DI2	0.1~100.0	2.0	ms	ALL
P112	Filter of digital input DI3	0.1~100.0	2.0	ms	ALL
P113	Filter of digital input DI4	0.1~100.0	2.0	ms	ALL
P114	Filter of digital input DI5	0.1~100.0	2.0	ms	ALL
P130	Function of digital output DO1	-11~11	2		ALL
P131	Function of digital output DO2	-11~11	3		ALL
P132	Function of digital output DO3	-11~11	8		ALL
P150	Range for positioning completion	0~32767	10	pulse	P
P151	Hysteresis for positioning completion	0~32767	5	pulse	P
P154	Arrival speed	-5000~5000	500	r/min	ALL
P155	Hysteresis of arrival speed	0~5000	30	r/min	ALL
P156	Polarity of arrival speed	0~1	0		ALL
P163	The way of position deviation clearing	0~1	0		P
P165	Speed check point for servomotor is near standstill	0~1000	5	r/min	ALL
P166	Delay time for electromagnetic brake when servomotor is in standstill	0~2000	0	ms	ALL
P167	Waiting time for electromagnetic brake when servomotor is in motion	0~2000	500	ms	ALL
P168	Action speed for electromagnetic brake when servomotor is in motion	0~3000	100	r/min	ALL

5.2 DI function table

Ordinal	Symbol	DI Function
0	NULL	Not have function
1	SON	Servo enable
2	ARST	Clear alarm
3	CCWL	CCW drive inhibition
4	CWL	CW drive inhibition
5	TCCW	CCW torque limitation
6	TCW	CW torque limitation
15	EMG	Emergency stop
18	GEAR1	Electronic gear switching 1
19	GEAR2	Electronic gear switching 2
20	CLR	Clear position deviation
21	INH	Pulse input inhibition

5.3 DO function table

Ordinal	Symbol	DO Function
0	OFF	Always invalid
1	ON	Always valid
2	RDY	Servo ready
3	ALM	Alarm
5	COIN	Positioning complete
6	ASP	Arrival speed
8	BRK	Electromagnetic brake
11	TRQL	Torque under limitation

5.4 Parameter description in detail

5.4.1 Parameters of section 0

P000	Password	Range	Default value	Unit	Usage
		0~9999	315		ALL

- Classifying parameter management can guarantee the parameters cannot modify by mistake.
- Setting this parameter as 315 can examine, modify the parameters of the 0, and 1 sections. For other setting only can examine, but cannot modify parameters.
- Some special operations need to set a suitable password.

P001	Identity code of servo driver	Range	Default value	Unit	Usage
		*	*		ALL

- This is the model of the servo driver in use now. The manufacturer sets it and the user cannot modify it.
- The meaning of this parameter are:
L08: TL08
L12: TL12
L16: TL16

P002	Identity code of servomotor	Range	Default value	Unit	Usage
		*	*		ALL

- This is the model of the servomotor in use now. The manufacturer sets it.
- The meaning of this parameter refers to the adaptive table of servomotor. See 7.4 sections.
- When replaces by different model of servomotor, it is necessary to modify this parameter. The concrete operation refers to the 3.7 sections.

P003	Software version	Range	Default value	Unit	Usage
		*	*		ALL

- This is the software version number and cannot be modified.

P004	Control mode	Range	Default value	Unit	Usage
		0~1	0		ALL

- The meanings of this parameter are:
0: Position control mode
1: Speed control mode

P005	Gain of speed loop	Range	Default value	Unit	Usage
		1~3000	40	Hz	P,S

- This is the proportion gain of the speed regulator. Increases the parameter value, can make the speed response to speed up. It is easy to cause the vibration and the noise when the value is too large.
- If the P017 (load inertia ratio) is a correct value then the parameter value is equal to the speed response bandwidth.

P006	Integral time constant of speed loop	Range	Default value	Unit	Usage
		1.0~1000.0	20.0	ms	P,S

- This is the integral time constant of the speed regulator. Reduces the parameter value, can reduce the speed control error, and increase rigidity. It is easy to cause the vibration and the noise when the value is too small.
- If using the maximum value (1000) indicates the integral function to be canceled. The speed regulator becomes the P controller.

P007	Filter time constant of torque	Range	Default value	Unit	Usage
		0.10~50.00	2.50	ms	ALL

- This is the low pass filter of torque and can suppress the vibration of the machinery.
- The bigger the value, the better effect of suppression achieves. The response will slow down. It is easy to cause oscillation if the value is too large. The smaller the value, the quicker response achieves, but can be limited by mechanical condition.
- When the load inertia is small, can set a small value; the load inertia is big, can set a big value.

P009	Gain of position loop	Range	Default value	Unit	Usage
		1~1000	40	1/s	P

- This is the proportional gain of the position regulator. Increases the parameter value, can reduce the position tracking error, and enhance the response. It is easy to cause overshoot or oscillation when the value is too large.

P017	Inertia ratio of load	Range	Default value	Unit	Usage
		0.0~200.0	1.5	-fold	P,S

- The load inertia ratio is that the inertia of mechanical load (refers to servomotor shaft) divides by the rotor inertia of the servomotor.

P019	Time constant of filter for speed detection	Range	Default value	Unit	Usage
		0.50~50.00	2.50	ms	P,S

- The bigger value of parameter can get the smoother detected speed signal. The smaller value of parameter can get the quicker responded signal, but it will cause noise if the value is too small. In addition, it will cause oscillation if the value is too big.

P021	Feed forward gain of position loop	Range	Default value	Unit	Usage
		0~100	0	%	P

- The feed forward can reduce position-tracking error in the position control mode. Under any frequency command pulse the position-tracking error always becomes zero if the parameter setting value is 100.
- Increasing the parameter value enhance the response of position control. It is easy to cause the system to be unstable, oscillation if the parameter value is too large.

P022	Time constant of feed forward filter for position loop	Range	Default value	Unit	Usage
		0.20~50.00	1.00	ms	P

- For filtering the feed forward signal in position loop. This function is to increase the stability of feed forward control.

P025	Sources of speed command	Range	Default value	Unit	Usage
		3~5	3		S

- Set the source of the speed command in speed control mode.
- The meanings of this parameter are:
 - 3: This is the JOG speed command. It needs to set this parameter when begins using the JOG operation.
 - 4: This is the button speed command. It needs to set this parameter when begins using the (Sr) operation.
 - 5: This is the demonstration speed command. It needs to set this parameter when begins using the demonstration operation. The speed command can change automatically.

P029	First numerator of electronic gear for command pulse	Range	Default value	Unit	Usage
		1~32767	1		P

- Use the frequency division or multiplication for the input pulse and can conveniently match with each kind of pulse source, also can achieve the pulse resolution for the user needs.
- The electronic gear numerator N of command pulse is determined by GEAR1 and GEAR2 from DI inputs. The denominator M is set by parameter P030.

DI Signals [note]		Numerator of electronic gear for command pulse N
GEAR2	GEAR1	
0	0	First numerator (parameter P029)
0	1	Second numerator (parameter P031)
1	0	Third numerator (parameter P032)
1	1	Fourth numerator (parameter P033)

Note: 0 indicates OFF; 1 indicates ON.

- The input pulse command becomes the position command by the N/M factor. The ratio range is: $1/50 < N/M < 200$

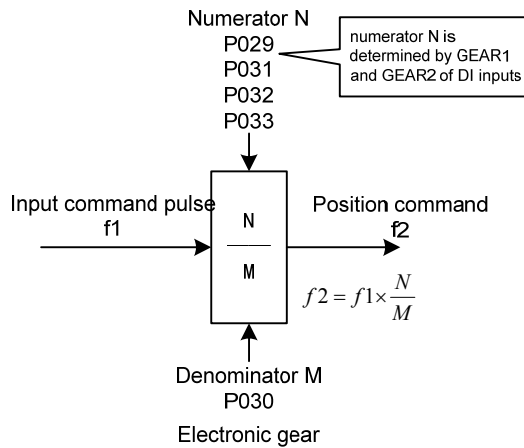

P030	Denominator of electronic gear for command pulse	Range	Default value	Unit	Usage
		1~32767	1		P

- This is electronic gear denominator M of command pulse. The application method refers to parameter P029.

P031	Second numerator of electronic gear for command pulse	Range	Default value	Unit	Usage
		1~32767	1		P

- Refer to the explanation of parameter P029.

P032	Third numerator of electronic gear for command pulse	Range	Default value	Unit	Usage
		1~32767	1		P

- Refer to the explanation of parameter P029.

P033	Fourth numerator of electronic gear for command pulse	Range	Default value	Unit	Usage
		1~32767	1		P

- Refer to the explanation of parameter P029.

P035	Input mode of command pulse	Range	Default value	Unit	Usage
		0~2	0		P

- Set the input mode of command pulse. The meanings of this parameter are:
 - 0: Pulse + Direction
 - 1: Positive/Reverse pulse
 - 2: Orthogonal pulse

Command pulse type	CCW	CW	Parameter P035
Pulse+ DIR			0
CCW pulse/ CW pulse			1
A phase+ B phase			2

Note: The arrow indicates the counting edge when P036=0, P037=0.

- The diagram of command pulse inputs

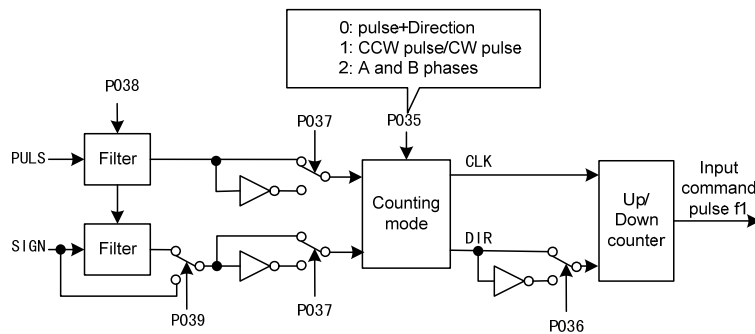

- The parameters needs to preserve firstly and then turn off and on the power supply.

P036	Input direction of command pulse	Range	Default value	Unit	Usage
		0~1	0		P

- The meanings of this parameter are:
 - 0: Normal direction
 - 1: Direction reverse

P037	Input signal logic of command pulse	Range	Default value	Unit	Usage
		0~3	0		P

- Set the phase of the input pulse signals PULS and SIGN for adjusting the counting edge as well as the counting direction.

P037	PULS signal phase	SIGN signal phase
0	In phase	In phase
1	Opposite phase	In phase
2	In phase	Opposite phase
3	Opposite phase	Opposite phase

- The parameters needs to preserve firstly and then turn off and on the power supply.

P038	Input signal filter of command pulse	Range	Default value	Unit	Usage
		0~21	7		P

- Filter the input signal PULS and SIGN numerically. The value is bigger then the filter time-constant is bigger.
- The maximum input pulse frequency is 500 kHz (kpps) when the setting value is seven. If the value is bigger, the maximum input pulse frequency will reduce correspondingly.
- Filter the noise from the input signal to avoid counting mistake. Because if found the running not perfect caused by the counting pulse, then can suitably increase the parameter value.
- The parameters needs to preserve firstly and then turn off and on the power supply.

P039	Input filter mode of command pulse	Range	Default value	Unit	Usage
		0~1	0		P

- The meanings of this parameter are:
 - 0: Filter the input signal PULS and SIGN numerically.
 - 1: Filter the input signal PULS only and not filter the SIGN signal.
- The parameters needs to preserve firstly and then turn off and on the power supply.

P040	Time-constant of exponential form filter for position command	Range	Default value	Unit	Usage
		0~1000	0	ms	P

- Carries on the smooth filter to the command pulse and has the exponential form acceleration/deceleration. The filter cannot lose the input pulse, but can delay the command pulse. When the setting value is zero, the filter does not have any effect.
- This filter uses in some cases:
 1. The host controller has no acceleration/deceleration function;
 2. The electronic gear ratio is quite big ($N/M > 10$);
 3. The command frequency is lower;
 4. When the servomotor is in motion appears step-by-steps or unstable phenomenon.

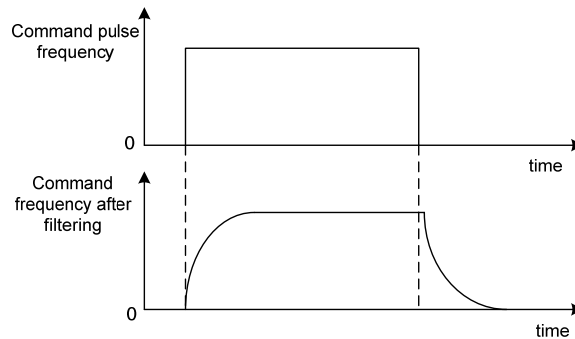

P060	Acceleration time of speed command	Range	Default value	Unit	Usage
		0~30000	0	Ms	S

- Set the acceleration time for the servomotor from the zero speed up to rated speed.
- If the command speed is lower than the rated speed, the rise time also correspondingly reduces.
- Only uses in the speed control mode. It is invalid in position control mode.
- If the servo driver constitutes the position control with host controller, this parameter should be set zero, otherwise affects the position control performance.

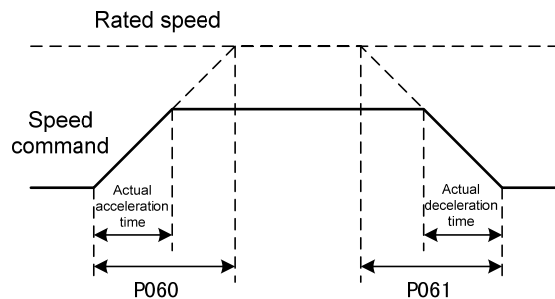

P061	Deceleration time of speed command	Range	Default value	Unit	Usage
		0~30000	0	ms	S

- Set the deceleration time for the servomotor from the rated speed down to zero speed.
- If the command speed is lower than the rated speed, the fall time also correspondingly reduces.
- Only uses in the speed control mode. It is invalid in position control mode.
- If the servo driver constitutes the position control with host controller, this parameter should be set zero, otherwise affects the position control performance.

P065	Internal torque limit in CCW direction	Range	Default value	Unit	Usage
		0~300	300	%	ALL

- Set the internal torque limitation value in CCW direction of servomotor.
- This limit is effective all the time.
- If the value surpasses the biggest overload capacity of the servo driver, then the actual limits will be equal to the biggest overload capacity.

P066	Internal torque limit in CW direction	Range	Default value	Unit	Usage
		-300~0	-300	%	ALL

- Set the internal torque limitation value in CW direction of servomotor.
- This limit is effective all the time.
- If the value surpasses the biggest overload capacity of the servo driver, then the actual limits will be equal to the biggest overload capacity.

P067	External torque limit in CCW direction	Range	Default value	Unit	Usage
		0~300	100	%	ALL

- Set the external torque limitation value in CCW direction of servomotor.
- This limit is effective if the TCCW (torque limit in CCW direction) is on by DI input.
- When limit is effective, the actual torque limitation will take the minimum value from the biggest overload capacity of the servo driver, the internal CCW torque limitation and the external CCW torque limitation.

P068	External torque limit in CW direction	Range	Default value	Unit	Usage
		-300~0	-100	%	ALL

- Set the external torque limitation value in CW direction of servomotor.
- This limit is effective if the TCW (torque limit in CW direction) is on by DI input.
- When limit is effective, the actual torque limitation will take the minimum value from the biggest overload capacity of the servo driver, the internal CCW torque limitation and the external CCW torque limitation.

P069	Torque limit in trial running	Range	Default value	Unit	Usage
		0~300	100	%	ALL

- Set the torque limitation value for trial running mode (the speed JOG movement, the button speed adjustment, the demonstration mode).
- The torque limitation is not related to the rotation direction. It is valid in both directions.
- The internal and the external torque limitation are still effective.

P070	Alarm level of torque overload in CCW direction	Range	Default value	Unit	Usage
		0~300	300	%	ALL

- Set the overload value of torque in (CCW) direction. This value indicates the percentage of rated torque.
- When the torque of the servomotor surpasses P070 and the duration is bigger than P072, then the servo driver alarms, and the servomotor stops. The number of the alarm is Err29.

P071	Alarm level of torque overload in CW direction	Range	Default value	Unit	Usage
		-300~0	-300	%	ALL

- Set the overload value of torque in (CW) direction. This value indicates the percentage of rated torque.
- When the torque of the servomotor surpasses P070 and the duration is bigger than P072, then the servo driver alarms, and the servomotor stops. The number of the alarm is Err29.

P072	Detection time for torque overload alarm	Range	Default value	Unit	Usage
		0~10000	0	10ms	ALL

- Refer to the explanation of parameter P070 and P071.
- The torque overload can be shielded if the setting value is zero.

P075	Maximum speed limit	Range	Default value	Unit	Usage
		0~5000	3500	r/min	ALL

- Set the permission highest speed of servomotor.
- The limit is effective in both CCW and CW direction.
- If the setting value surpasses the system permission the maximum speed, the actual speed also can limit in the maximum speed.

P076	JOG running speed	Range	Default value	Unit	Usage
		0~5000	100	r/min	S

- Set the running speed for JOG operation.

P080	Position deviation limit	Range	Default value	Unit	Usage
		0.00~327.67	4.00	circle	P

- Set the position deviation range for alarm when the deviation exceeds this parameter.
- Under position control mode, when the counting value of position deviation counter exceeds the pulses corresponding to this parameter value, the servo driver gives the position deviation alarm (Err 4).
- The unit is one circle. Multiplying the resolution of encoder with the value of this parameter can obtain the total pulse number. For example, the encoder has 2500 lines and the resolution of encoder is 10000. If the parameter value is 4.00, then corresponds to 40000 pulses.

P096	Items of initial display	Range	Default value	Unit	Usage
		0~22	0		ALL

- Set the display status on the front panel after turn on the power supply. The meanings of this parameter are:

P096	Display item	P096	Display item
0	Speed of servomotor	12	Reserved
1	Original Position command	13	Reserved
2	Position command	14	Digital input DI
3	Position of servomotor	15	Digital output DO
4	Position deviation	16	Signals of encoder
5	Torque	17	Absolute position in one turn
6	Peak torque	18	Accumulative load ratio
7	Current	19	Brake ratio
8	Peak current	20	Control mode
9	Frequency of input pulse	21	Number of alarm
10	Speed command	22	Reserved
11	Torque command		

P097	Neglect inhibition of servo driver	Range	Default value	Unit	Usage
		0~3	3		ALL

- The prohibited positive travel (CCWL) and the prohibited reverse travel (CWL) from DI inputs are used for the limit traveling protection. Use normal closed switch as protecting switch. If the input from DI is ON, then the servomotor can move to this direction, or is OFF, cannot move to this direction. If does not use the limit traveling protection, can neglect it by modifying this parameter and does not need the CCWL and CWL wiring.
- The default value neglects the prohibition, if use this function, please modify this value first.
- The meanings of this parameter are:

P097	Motion inhibition in CW direction(CWL)	Motion inhibition in CCW direction(CCWL)
0	Use	Use
1	Use	Neglect
2	Neglect	Use
3	Neglect	Neglect

Use: When input signal is ON, the servomotor can move to this direction; When OFF the servomotor cannot move to this direction.

Neglect: The servomotor can move to this direction, and the prohibition signal does not have the function, therefore can disconnect this signal.

P098	Forced enable	Range	Default value	Unit	Usage
		0~1	0		ALL

- The meanings of this parameter are:
 - 0: The enable signal SON comes from inputs by DI;
 - 1: The enable signal comes from internal software.

5.4.2 Parameters of section 1

P100	Function of digital input DI1	Range	Default value	Unit	Usage
		-21~21	1		ALL

- The function plan of digital input DI1: the absolute value of the parameter expresses functions; the symbolic expresses the logic. Refer to the 5.5 sections for the functions.
- The symbolic expresses the input logic. Positive number expresses positive logic and the negative number express the negative logic. ON is effective, OFF is invalid:

Parameter	DI input signal	DI Result
Positive number	Turn off	OFF
	Turn on	ON
Negative number	Turn off	ON
	Turn on	OFF

- If set the same function for many input channel, the function results in logical 'or' relations. For example P100 and P101 are set by 1 (the SON function), then DI1 and/or DI2 is ON, the SON is effective.
- The input function which is not selected by parameter P100~P104, namely the undefined function, results in OFF (invalid).

P101	Function of digital input DI2	Range	Default value	Unit	Usage
		-21~21	2		ALL

- The function plan of digital input DI2. Refer to the explanation of parameter P100.

P102	Function of digital input DI3	Range	Default value	Unit	Usage
		-21~21	3		ALL

- The function plan of digital input DI3. Refer to the explanation of parameter P100.

P103	Function of digital input DI4	Range	Default value	Unit	Usage
		-21~21	4		ALL

- The function plan of digital input DI4. Refer to the explanation of parameter P100.

P104	Function of digital input DI5	Range	Default value	Unit	Usage
		-21~21	20		ALL

- The function plan of digital input DI5. Refer to the explanation of parameter P100.

P110	Filter of digital input DI1	Range	Default value	Unit	Usage
		0.1~100.0	2.0	ms	ALL

- This is the time-constant of DI1 input digital filter.
- The smaller the value, the quicker signal responses; the bigger the value, the slower signal responses, but filtering ability of noise is stronger.

P111	Filter of digital input DI2	Range	Default value	Unit	Usage
		0.1~100.0	2.0	ms	ALL

- This is the time-constant of DI2 input digital filter. Refer to the explanation of parameter P110.

P112	Filter of digital input DI3	Range	Default value	Unit	Usage
		0.1~100.0	2.0	ms	ALL

- This is the time-constant of DI3 input digital filter. Refer to the explanation of parameter P110.

P113	Filter of digital input DI4	Range	Default value	Unit	Usage
		0.1~100.0	2.0	ms	ALL

- This is the time-constant of DI4 input digital filter. Refer to the explanation of parameter P110.

P114	Filter of digital input DI5	Range	Default value	Unit	Usage
		0.1~100.0	2.0	ms	ALL

- This is the time-constant of DI5 input digital filter. Refer to the explanation of parameter P110.

P130	Function of digital output DO1	Range	Default value	Unit	Usage
		-11~11	2		ALL

- The function plan of digital output DO1: The absolute value of the parameter expresses functions; the symbol expresses the logic, Refer to the 5.6 sections for the functions.
- '0' is forcing OFF, '1' is forcing ON.
- The symbol indicates the output logic; the positive number expresses the positive logic and the negative number expresses the negative logic:

Parameter value	Function	DO output signal
Positive number	ON	Turn on
	OFF	Turn off
Negative number	ON	Turn off
	OFF	Turn on

P131	Function of digital output DO2	Range	Default value	Unit	Usage
		-11~11	3		ALL

- This is the function plan of digital output DO2. Refer to the explanation of parameter P130.

P132	Function of digital output DO3	Range	Default value	Unit	Usage
		-11~11	8		ALL

- This is the function plan of digital output DO3. Refer to the explanation of parameter P130.

P150	Range for positioning completion	Range	Default value	Unit	Usage
		0~32767	10	Pulse	P

- Set the pulse range for positioning completion under the position control mode.
- When the pulse number in the position deviation counter is smaller than or equal to this setting value, the digital output DO COIN is ON (positioning completion), otherwise is OFF.
- The comparator has hysteric function set by parameter P151.

P151	Hysteresis for positioning completion	Range	Default value	Unit	Usage
		0~32767	5	Pulse	P

- Refer to the explanation of parameter P150.

P154	Arrival speed	Range	Default value	Unit	Usage
		-5000~5000	500	r/min	ALL

- When the servomotor speed surpasses this parameter, the digital output DO ASP (speed arrives) is ON, otherwise is OFF.
- The comparator has hysteretic function set by parameter P155.
- Has the polarity setting function:

P156	P154	Comparator
0	>0	Detect CCW or CW speed
1	>0	Only detect CCW speed
	<0	Only detect CW speed

P155	Hysteresis of arrival speed	Range	Default value	Unit	Usage
		0~5000	30	r/min	ALL

- Refer to the explanation of parameter P154.

P156	Polarity of arrival speed	Range	Default value	Unit	Usage
		0~1	0		ALL

- Refer to the explanation of parameter P154.

P163	The way of position deviation clearing	Range	Default value	Unit	Usage
		0~1	0		P

- In the position control mode, use the CLR input signal (clear position deviation) from DI to clear the position deviation counter.
- The meaning of this parameter are:(at the time when the position deviation elimination occurs)
0: The high level of CLR ON.
1: The rising edge of CLR ON (the moment from OFF to ON).

P165	Range for static check of the servomotor.	Range	Default value	Unit	Usage
		0~1000	5	r/min	ALL

- Use this parameter to check the servomotor to be static. If the speed of the servomotor is lower than the parameter value and will consider the servomotor static.
- Only uses in the timing chart judgment of the electromagnetic brake.

P166	Delay time for electromagnetic brake when servomotor is in standstill	Range	Default value	Unit	Usage
		0~2000	0	ms	ALL

- Use the electromagnetic brake when the SON is from ON go to OFF or alarm occurs in the servo driver. This parameter defines the delay time from the action (the BRK is OFF from DO terminals) of the electromagnetic brake until excitation removal of the servomotor during the servomotor to be in static.
- The parameter should not be smaller than the delay time in which the machinery applies the brake. This parameter will make the brake reliable and then turns off the servomotor excitation to guarantee against the small displacement of the servomotor or depreciation of the work piece.
- The timing chart refers to 4.7.3 section.

P167	Waiting time for electromagnetic brake when servomotor is in motion	Range	Default value	Unit	Usage
		0~2000	500	ms	ALL

- Use the electromagnetic brake when the SON is from ON go to OFF or alarm occurs in the servo driver. This parameter defines the delay time from excitation removal of the servomotor until the action (the BRK is OFF from DO terminals) of the electromagnetic brake during the servomotor to be in motion.
- This parameter will make the servomotor deceleration from high speed down to low speed and then applies the brake to avoid damaging the brake.
- The actual action time will take the minimum value in both the parameter P167 and the time in which the servomotor decelerates to the P168 value.
- The timing chart refers to 4.7.4 section.

P168	Action speed for electromagnetic brake when servomotor is in motion	Range	Default value	Unit	Usage
		0~3000	100	r/min	ALL

- Refer to the explanation of parameter P167.

5.5 DI function description in detail

Ordinal	Symbol	Function	Function explanation								
0	NULL	Not have function	The input condition does not have any influence to the system.								
1	SON	Servo enable	OFF: servo driver does not enable, servomotor does not excite; ON : servo driver has enabled, servomotor has excited.								
2	ARST	Clear alarm	When an alarm occurs and the alarm has permission to clear, then the rising edge (from OFF becomes ON) of input signal ARST will clear the alarm. Attention: only a part of alarm can have the permission to clear.								
3	CCWL	CCW drive inhibition	<p>OFF: Inhibit CCW running; ON : Enable CCW running.</p> <p>Uses this function for protection of the mechanical traveling limit, the function is controlled by the parameter P097. Pays attention to that the P097 default value neglects this function, therefore needs to modify P097 if needs to use this function:</p> <table border="1"> <thead> <tr> <th>P097</th> <th>Explanation</th> </tr> </thead> <tbody> <tr> <td>0</td> <td rowspan="2">Use CCW prohibition function and must connect the normally closed contact of the limit switch.</td> </tr> <tr> <td>2</td> </tr> <tr> <td>1</td> <td rowspan="2">Neglect CCW prohibition function, this signal does not have any influence to CCW movement of the servomotor, and therefore does not need the CCWL wiring.</td> </tr> <tr> <td>3(Default)</td> </tr> </tbody> </table>	P097	Explanation	0	Use CCW prohibition function and must connect the normally closed contact of the limit switch.	2	1	Neglect CCW prohibition function, this signal does not have any influence to CCW movement of the servomotor, and therefore does not need the CCWL wiring.	3(Default)
P097	Explanation										
0	Use CCW prohibition function and must connect the normally closed contact of the limit switch.										
2											
1	Neglect CCW prohibition function, this signal does not have any influence to CCW movement of the servomotor, and therefore does not need the CCWL wiring.										
3(Default)											

Chapter 5 Parameters

Ordinal	Symbol	Function	Function explanation															
4	CWL	CW drive inhibition	<p>OFF: Inhibit CW running; ON : Enable CW running.</p> <p>Uses this function for protection of the mechanical traveling limit, the function is controlled by the parameter P097. Pays attention to that the P097 default value neglects this function, therefore needs to modify P097 if needs to use this function:</p> <table border="1"> <thead> <tr> <th>P097</th> <th>Explanation</th> </tr> </thead> <tbody> <tr> <td>0</td> <td rowspan="2">Use CW prohibition function and must connect the normally closed contact of the limit switch.</td> </tr> <tr> <td>1</td> </tr> <tr> <td>2</td> <td rowspan="2">Neglect CW prohibition function, this signal does not have any influence to CW movement of the servomotor, and therefore does not need the CWL wiring.</td> </tr> <tr> <td>3(default)</td> </tr> </tbody> </table>	P097	Explanation	0	Use CW prohibition function and must connect the normally closed contact of the limit switch.	1	2	Neglect CW prohibition function, this signal does not have any influence to CW movement of the servomotor, and therefore does not need the CWL wiring.	3(default)							
P097	Explanation																	
0	Use CW prohibition function and must connect the normally closed contact of the limit switch.																	
1																		
2	Neglect CW prohibition function, this signal does not have any influence to CW movement of the servomotor, and therefore does not need the CWL wiring.																	
3(default)																		
5	TCCW	CCW torque limitation	<p>OFF: Torque is not limited by parameter P067 in CCW direction; ON : Torque is limited by parameter P067 in CCW direction.</p> <p>Attention: whether the TCCW is effective or not, the torque is also limited by the parameter P065 in CCW direction.</p>															
6	TCW	CW torque limitation	<p>OFF: Torque is not limited by parameter P068 in CW direction; ON : Torque is limited by parameter P068 in CW direction.</p> <p>Attention: whether the TCW is effective or not, the torque is also limited by the parameter P066 in CW direction.</p>															
15	EMG	Emergency stop	<p>OFF: Permits the servo driver to work; ON : Servo driver stops; removes the main current and the excitation of servomotor.</p>															
18	GEAR1	Electronic gear switching 1	<p>Select electronic gear for command pulse by the combination of GEAR1 and GEAR2 1~4:</p> <table border="1"> <thead> <tr> <th>GEAR2</th> <th>GEAR1</th> <th>Numerator of electronic gear N</th> </tr> </thead> <tbody> <tr> <td>0</td> <td>0</td> <td>1st numerator(parameterP029)</td> </tr> <tr> <td>0</td> <td>1</td> <td>2nd numerator(parameterP031)</td> </tr> <tr> <td>1</td> <td>0</td> <td>3rd numerator(parameterP032)</td> </tr> <tr> <td>1</td> <td>1</td> <td>4th numerator(parameterP033)</td> </tr> </tbody> </table> <p>Note: 0 indicates OFF; 1 indicates ON.</p>	GEAR2	GEAR1	Numerator of electronic gear N	0	0	1 st numerator(parameterP029)	0	1	2 nd numerator(parameterP031)	1	0	3 rd numerator(parameterP032)	1	1	4 th numerator(parameterP033)
GEAR2	GEAR1	Numerator of electronic gear N																
0	0	1 st numerator(parameterP029)																
0	1	2 nd numerator(parameterP031)																
1	0	3 rd numerator(parameterP032)																
1	1	4 th numerator(parameterP033)																
19	GEAR2	Electronic gear switching 2																

5.5 DI function description in detail

Ordinal	Symbol	Function	Function explanation
20	CLR	Clear position deviation	Eliminates the position deviation counter; The elimination mode is selected by the parameter P163; The elimination of position deviation occurs in the moment: P163=0: CLR ON Level: P163=1: CLR Rising edge (from OFF become ON).
21	INH	Pulse input inhibition	OFF: Permits position command pulse to go through: ON : Position command pulse is inhibited.

5.6 DO function description in detail

Ordinal	Symbol	Function	Function explanation
0	OFF	Always invalid	Forced output OFF.
1	ON	Always valid	Forced output ON.
2	RDY	Servo ready	OFF: Servo main power supply is off; Or alarm occurs; ON : Servo main power supply is normal, no alarm occurs.
3	ALM	Alarm	OFF: Alarm occurs; ON : No alarm occurs.
5	COIN	Positioning complete	In position control mode OFF: Position deviation is bigger than parameter P150; ON : Position deviation is smaller than parameter P150.
6	ASP	Arrival speed	OFF: Servomotor speed is lower than parameter P154; ON : Servomotor speed is higher than parameter P154. Can set polarity function, refers to the explanation of parameter P154.
8	BRK	Electromagnetic brake	OFF: Electromagnetic brake applies the brake; ON : Electromagnetic brake releases the brake.
11	TRQL	Torque under limitation	OFF: Servomotor torque has not reached the limit value; ON : Servomotor torque has reached the limit value. Torque limitation is set by parameter P064.

Chapter 6 Alarm

6.1 Alarm table

Alarm code	Alarm name	Alarm content	Alarm clear
Err--	No alarm occurs	Normal operation	
Err 1	Over speed	Servomotor speed exceeds the speed limit.	No
Err 2	Over voltage of the main power supply	The voltage of the main power supply exceeds the specified value.	No
Err 4	Position deviation exceeds the limit value	The counter of position deviation exceeds the setting limit value.	Can
Err 7	Drive inhibition abnormal	CCWL、CWL the inputs of drive inhibition are not effective.	Can
Err 8	Overflow of position deviation counter	The absolute value of position deviation counter exceeds 2^{30}	Can
Err 9	Encoder signal fault	Lack of the signals of encoder	No
Err11	Power model fault	Power model fault occurs.	No
Err12	Over current	Over-current of servomotor	No
Err13	Overload	Overload of servomotor	No
Err14	Overload of brake peak power	Instantaneous load is too big in short brake time	No
Err15	Encoder counter error	Encoder counter is abnormal.	No
Err16	Over-heat of servomotor	The heat load of servomotor exceeds the setting value (I^2t detection)	No
Err17	Overload of brake average power	Average load is too big in brake time	No
Err18	Overload of power model	Average output load of power model is too big	No
Err20	EEPROM error	EEPROM error occurs when read or write.	No
Err21	Logic circuit error	Logic circuit fault outside DSP	No
Err23	AD conversion error	Circuit or current sensor fault	No
Err24	Under voltage of control power supply	The LDO fault of control circuit	No
Err29	Over-torque alarm	The torque of servomotor exceeds the setting value and lasting time	Can

Chapter 6 Alarm

Err30	Lost Z signal of encoder	Z signal of encoder is loss.	No
Err31	UVW signals error of encoder	The UVW Signals error or pole number does not match with the servomotor	No
Err32	Illegal code of encoder UVW signals	UVW signals are all high level or low level	No
Err33	Error signal of saving wire encoder	Has no high resistance in the timing chart when power supply turns on.	No

6.2 The reason and handling of alarm

Err 1 (Over speed)

Potential cause	Check	Handle
Servomotor U、 V、 W connection is not correct	Check U、 V、 W wiring	Correct U、 V、 W wiring. The U、 V、 W must connect with servo driver terminal U、 V、 W correspondently.
Speed overshoot	Check the operation status and the parameters.	Adjust servo gain to reduce the overshoot; In speed control mode can increase acceleration/deceleration time.
Encoder wiring error	Check the encoder wiring	Correct wiring.

Err 2 (Main circuit over-voltage)

Potential cause	Check	Handle
The voltage of input AC power supply is too high	Check the voltage of power supply	Use correct power supply according with the specifications.
Regeneration fault	Regenerative resistor and/or IGBT damaged; Connection circuit is open.	Repair.
Regeneration energy too large	Check the regeneration load factor	<ul style="list-style-type: none"> ● Slow down the starting and stopping frequency. ● Increasing acceleration/deceleration time setting. ● Reduce the torque limit. ● Reduce the load inertia. ● Replace the servo driver and servomotor with bigger ones.

Err 4 (Excess position deviation)

Potential cause	Check	Handle
Servomotor U、V、W connection is not correct	Check U、V、W wiring	Correct U、V、W wiring. The U、V、W must connect with servo driver terminal U、V、W correspondently.
Encoder zero point changes	Check the encoder zero point	Install the encoder again and adjust the zero point.
The encoder wiring error	Check the encoder wiring	Correct wiring.
The servomotor is blocked	Check the servomotor shaft and its mechanical connection	Repair.
The command pulse frequency is too high	Check input frequency and the parameter of division/multiplication	<ul style="list-style-type: none"> ● Slow down the input frequency. ● Adjust the parameter of division/multiplication.
The gain of position loop is too small	Check the parameters P009	Increasing the gain of position loop.
The excess position deviation range is too small	Check the parameter P079	Increasing the value of parameter P079.
Torque is not enough big	Check torque	<ul style="list-style-type: none"> ● Increase the torque limit. ● Increase smooth filtering time for position command. ● Reduce load. ● Replace the servo driver and servomotor with bigger ones.

Err 7 (Drive inhibition abnormal)

Potential cause	Check	Handle
The CCWL and/or CWL over-travel inhibition is invalid when servo is on	Check CCWL、CWL wiring	<ul style="list-style-type: none"> ● Correct input CCWL、CWL signal. ● If not use CCWL、CWL signal can shield it by setting parameter P097.

Err 8 (Overflow of position deviation counter)

Potential cause	Check	Handle
The servomotor is blocked	Check the servomotor shaft and its mechanical connection	Repair.
The command pulse is abnormal	Check command pulse	

Err 9 (Encoder signal fault)

Potential cause	Check	Handle
Encoder wiring error	Check the encoder wiring	Correct wiring.
Encoder cable and/or connector is bad	Check cable and connector	Replace the cable and connector.
Servomotor type setting is not correct.	Check the servomotor type	Set the servomotor type again.
Encoder is damaged	Check the encoder	Replace the encoder.

Err11 (IGBT model fault)

Potential cause	Check	Handle
Short-circuit at drive output (U、V、W)	Check U、V、W wiring	Repair or replace the short-circuited wiring.
Motor winding insulation is damaged	Check the servomotor	Known the servomotor to be no fault, and then turn on the power supply again, if the alarm still exists, the servo driver may damage possibly. Replace the servo driver.
Servo driver is damaged	Check the servo driver	Replace the servo driver.
Ground is bad	Check the ground wiring	Ground correctly.
Suffer from interference	Check interference source	Adds line filter; Keep away interference source.

Err12 (Over-current)

Potential cause	Check	Handle
Short-circuit at drive output (U、V、W)	Check the wiring connections between servo driver and servomotor.	Repair or replace the short-circuited wiring.
Motor winding insulation is damaged	Check the servomotor	Replace the servomotor.
Servo driver is damaged	Check the servo driver	Known the servomotor to be no fault, and then turn on the power supply again, if the alarm still exists, the servo driver may damage possibly. Replace the servo driver.

Err13 (Over-load)

Potential cause	Check	Handle
Excess the rated load for continuous duty operation	Check the load factor	Reduce load or replace the servo driver with bigger one.
System unstable	Check the oscillation when servomotor is in running	Reduce the gains of the system.
Acceleration/deceleration is too short	Check the smoothness when servomotor is in running	Increasing acceleration/deceleration time setting.
Encoder zero point changes	Check the encoder zero point	Install the encoder again and adjust the zero point.

Err14 (Overload of brake peak power)

Potential cause	Check	Handle
The voltage of input AC power supply is too high	Check the voltage of power supply	Use correct power supply according with the specifications.
Regeneration fault	Regenerative resistor and/or IGBT damaged; Connection circuit is open.	Repair.
Regeneration energy too large	Check the regeneration load factor	<ul style="list-style-type: none"> ● Slow down the starting and stopping frequency. ● Increasing acceleration/deceleration time setting. ● Replace the servo driver and servomotor with bigger ones.

Err15 (Encoder counter error)

Potential cause	Check	Handle
Encoder wiring error	Check the encoder wiring	Correct wiring included shield wire.
Ground is bad	Check the ground wiring	Ground correctly.
Suffer from interference	Check interference source	Keep away interference source.
Encoder has problem	<ul style="list-style-type: none"> ● Check the line number and pole number ● Check the encoder Z signal ● Encoder damaged 	Replace the encoder.

Err16 (Motor over-heat)

Potential cause	Check	Handle
Excess the rated load for continuous duty operation	Check the load factor and the rise in temperature of motor	Reduce load or replace the servo driver with bigger one.
Encoder zero point changes	Check the encoder zero point	Install the encoder again and adjust the zero point.

Err17 (Overload of brake average power)

Potential cause	Check	Handle
The voltage of input AC power supply is too high	Check the voltage of power supply	Use correct power supply according with the specifications.
Regeneration energy too large	Check the regeneration load factor	<ul style="list-style-type: none"> ● Slow down the starting and stopping frequency. ● Increase acceleration /deceleration time setting. ● Reduce the torque limit. ● Decreasing the load inertia. ● Replace the servo driver and servomotor with bigger ones.

Err18 (IGBT model over-load)

Potential cause	Check	Handle
Excess the rated load for continuous duty operation	Check current	Reduce load or replace the servo driver with bigger one.
Encoder zero point changes	Check the encoder zero point	Install the encoder again and adjust the zero point.

Err20 (EEPROM Error)

Potential cause	Check	Handle
EEPROM chip is damaged	Turn on the power again and check	If the error still exists, then replace the servo driver.

Err21 (Logic circuit error)

Potential cause	Check	Handle
Control circuit fault	Turn on the power again and check	If the error still exists, then replace the servo driver.

Err23 (AD conversion error)

Potential cause	Check	Handle
Current sensor and connector fault	Check the main circuit	Replace the servo driver.
AD converter and analog amplifier fault	Check the control circuit	Replace the servo driver.

Err24 (Under voltage of control power supply)

Potential cause	Check	Handle
Control circuit LDO fault	Check the power of control board	Replace the servo driver.

Err29 (Over-torque alarm)

Potential cause	Check	Handle
Unexpected big load occurs	Check load condition	Correctly readjust the load.
Parameter P070、P071、P072 setting is not reasonable	Check the parameters	Correctly readjust parameters.

Err30 (Lost Z signal of encoder)

Potential cause	Check	Handle
Encoder has problem	Check the encoder Z signal	Replace the encoder.
Encoder cable and/or connector has problem	Check cable and connector	Replace the cable and connector.
The interface circuit of the servo driver is at fault	Check the control circuit	Replace the servo driver.

Err31 (UVW signals error of encoder)

Potential cause	Check	Handle
Encoder has problem	<ul style="list-style-type: none"> ● Check the line number and pole number ● Check the encoder UVW signals ● Encoder damaged 	Replace the encoder.
Encoder wiring error	Check the encoder wiring	Correct wiring included shield wire.

Err32 (Illegal code of encoder UVW signals)

Potential cause	Check	Handle
Encoder has problem	Check the encoder UVW signals	Replace the encoder.
Encoder wiring error	Check the encoder wiring	Correct wiring included shield wire.

Err33 (Wire saving encoder error)

Potential cause	Check	Handle
Encoder has problem	Check the encoder signals	Replace the encoder.
Servomotor type setting is not correct	Check the servomotor type; Confirm that the servomotor is adapted with the wire saving encoder.	Set the servomotor type again.

Chapter 7 Specifications

7.1 Types of servo driver

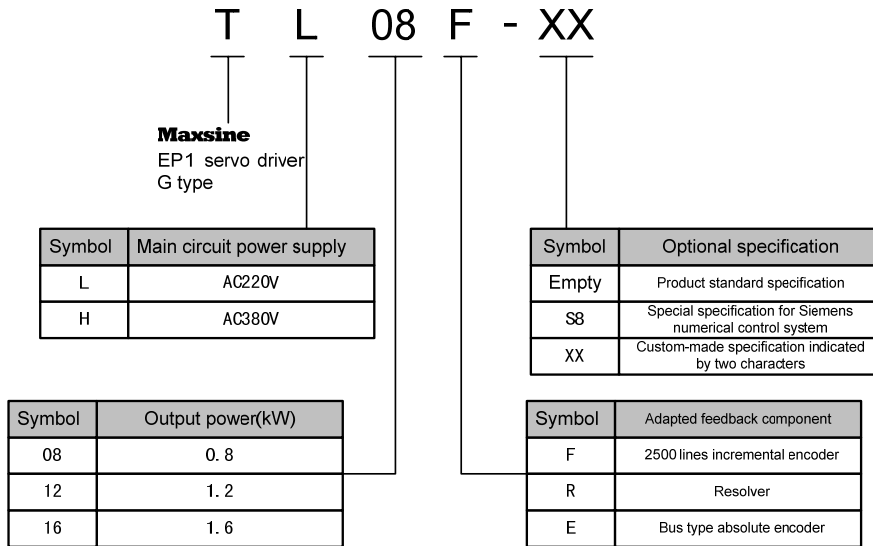

7.2 Dimensions of servo driver

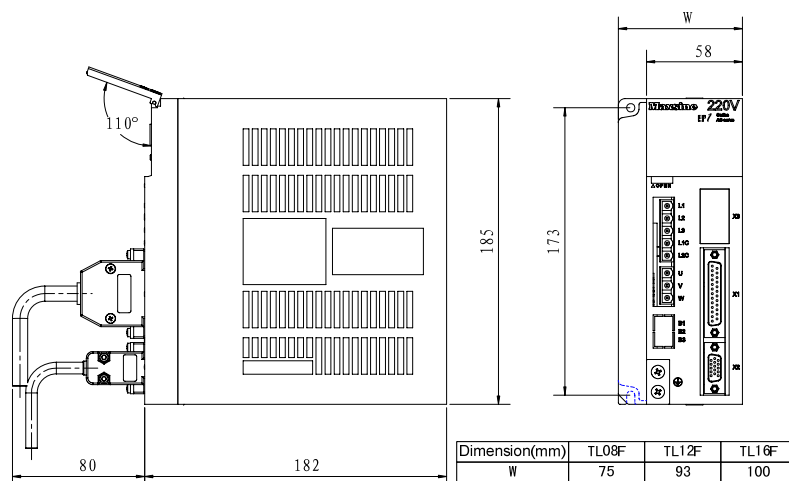

7.3 Specifications of servo driver

Type	TL08F	TL12F	TL16F
Power supply	Three-phase AC220V -15%~+10% 50/60Hz		
Environment	Temperature	Operation: 0~40°C Storage: -40~50°C	
	Humidity	Operation: 40%~80% (non-condensing) Storage: 93% or less(non-condensing)	
IP rating	IP20		
Control of main circuit	SVPWM control		
Regeneration	Built-in		
Feedback type	2500 ppr incremental encoder, 2500ppr wire saving encoder (10000 resolution)		
Control modes	Position		
Digital inputs	Five programmable input terminals (optical isolation), Functions are: Servo-ON, Alarm clear, CCW over-travel inhibition, CW over-travel inhibition, CCW torque limit, CW torque limit, Emergency stop, Electronic gear select 1, Electronic gear select 2, Position deviation clear, Pulse input inhibition.		
Digital outputs	Three programmable output terminals (optical isolation), Functions are: Servo ready, Servo alarm, Positioning complete, At speed reached, Electromagnetic brake release, Torque in-limit.		
Encoder signal outputs	Signal type	A、B、Z (Differential output line driver), Z signal (open collector output)	
Position	Input frequency	Differential input: ≤500kHz(kpps); Single-end input: ≤200kHz(kpps).	
	Command modes	Pulse+Direction: CCW pulse+CW pulse; A phase+B phase(orthogonal).	
	Electronic gear ratio	1~32767/1~32767	
Monitor function	Speed, current position, position deviation, motor torque, motor current, command pulse frequency, etc.		
Protection function	Over-speed, over-voltage, over-current, over-load, regeneration abnormal, encoder signal abnormal, excess position deviation, etc.		
Characteristic	Frequency response of speed	>300Hz	
	Fluctuation of speed	<±0.03%(load 0~100%); <±0.02%(power supply -15~+10%)	
	Speed control range	1:5000	

7.4 Adaptive table for servo motor selections

Servomotor parameters					Adaptable servo driver [note3、note4]		
Servomotor ID code [note 1]	Servomotor type [note 2]	Rated torque (N·m)	Rated speed (r/min)	Rated power (kW)	TL08	TL12	TL16
A081	80ST-M01330L	1.3	3000	0.4	●	●	●
A082	80ST-M02430L	2.4	3000	0.75	●	●	●
A083	80ST-M03330L	3.3	3000	1.0	●	●	●
A101	110ST-M02030L	2	3000	0.6	●	●	●
A102	110ST-M04030L	4	3000	1.2	●	●	●
A103	110ST-M05030L	5	3000	1.5		●	●
A104	110ST-M06020L	6	2000	1.2		●	●
A105	110ST-M06030L	6	3000	1.6		●	●
A301	130ST-M04025L	4	2500	1.0	●	●	●
A302	130ST-M05020L	5	2000	1.0	●	●	●
A303	130ST-M05025L	5	2500	1.3	●	●	●
A304	130ST-M06025L	6	2500	1.5		●	●
A305	130ST-M07720L	7.7	2000	1.6		●	●
A306	130ST-M07725L	7.7	2500	2.0		●	●
A307	130ST-M07730L	7.7	3000	2.4			●
A308	130ST-M10015L	10	1500	1.5		●	●
A309	130ST-M10025L	10	2500	2.6			●
A310	130ST-M15015L	15	1500	2.3		●	●
A311	130ST-M15025L	15	2500	3.8			
A501	150ST-M15025L	15	2500	3.8			
A502	150ST-M18020L	18	2000	3.6			
A503	150ST-M23020L	23	2000	4.7			
A505	150ST-M27020L	27	2000	5.5			

● Indicate to be able to adapt

Note 1: Servomotor code for parameter P002 setting in servo driver.

Note 2: 80ST-M01330L、80ST-M02430L、80ST-M03330L servomotors adapts with 2500line wire saving encoder;The rest of servomotor adapts with 2500line standard encoder.

Note 3: One servomotor can adapt more than one servo driver, The higher power of servo driver can provide higher overload factor and often start-stop is suitable.

Note 4: Use EP100-5A servo driver for non-adaptive servomotors.

7.5 Types of servo motor

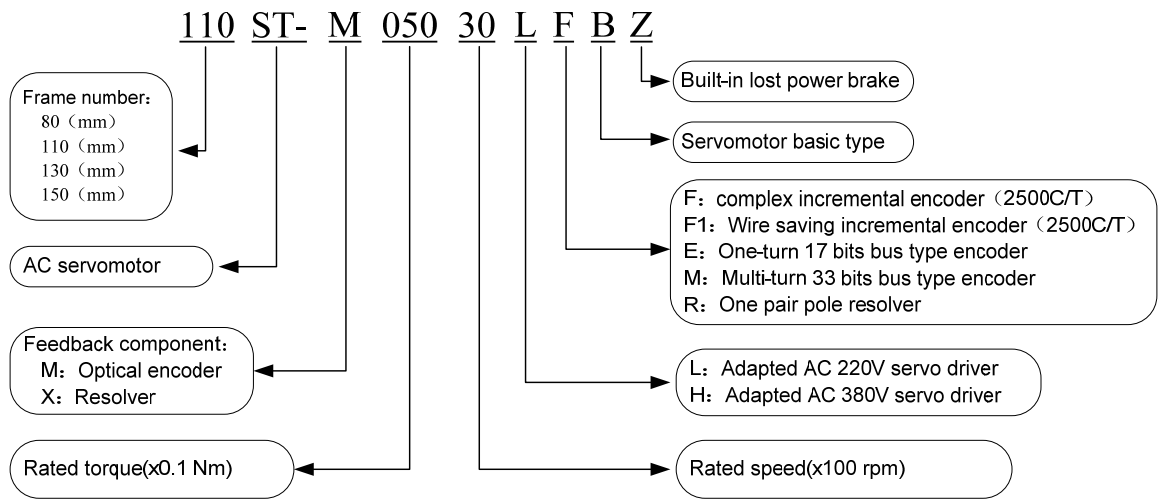

7.6 Servo motor wiring

7.6.1 Winding wiring

Terminal symbol	Terminal number	Terminal explanation
U	2	U phase drive input
V	3	V phase drive input
W	4	W phase drive input
⊕	1	Ground terminal of motor case

7.6.2 Holding brakes

Terminal symbol	Terminal number	Terminal explanation
DC+	1	Brake input power
DC-	2	
⊕	3	Ground terminal of motor case

7.6.3 Standard encoders

Terminal symbol	Terminal number	Terminal explanation
5V	2	5V input power
0V	3	
A+	4	A phase output
A-	7	
B+	5	B phase output
B-	8	
Z+	6	Z phase output
Z-	9	
U+	10	U phase output
U-	13	
V+	11	V phase output
V-	14	
W+	12	W phase output
W-	15	
FG	1	Metal case of encoder

7.6.4 Wire saving encoders

Terminal symbol	Terminal number	Terminal explanation
5V	2	5V input power
0V	3	
A+	4	A phase output
A-	7	
B+	5	B phase output
B-	8	
Z+	6	Z phase output
Z-	9	
FG	1	Metal case of encoder

7.7 Parameters of servo motor

7.7.1 Parameters of 80 series servo motor

Type	80ST-M01330L	80ST-M02430L	80ST-M03330L
Rated output power (kW)	0.4	0.75	1.0
Rated torque (Nm)	1.3	2.4	3.3
Rated speed(r/min)	3000	3000	3000
Rated current(A)	2.6	4.2	4.8
Rotor inertia (Kg·m ²)	0.74×10^{-4}	1.2×10^{-4}	1.58×10^{-4}
Weight (kg)	2.2	2.8	3.3
Line numbers of encoder	2500 line/pr (wire saving type)		
Pole pair number	4 pair		
Insulation class	Class B		
IP rating	IP65		

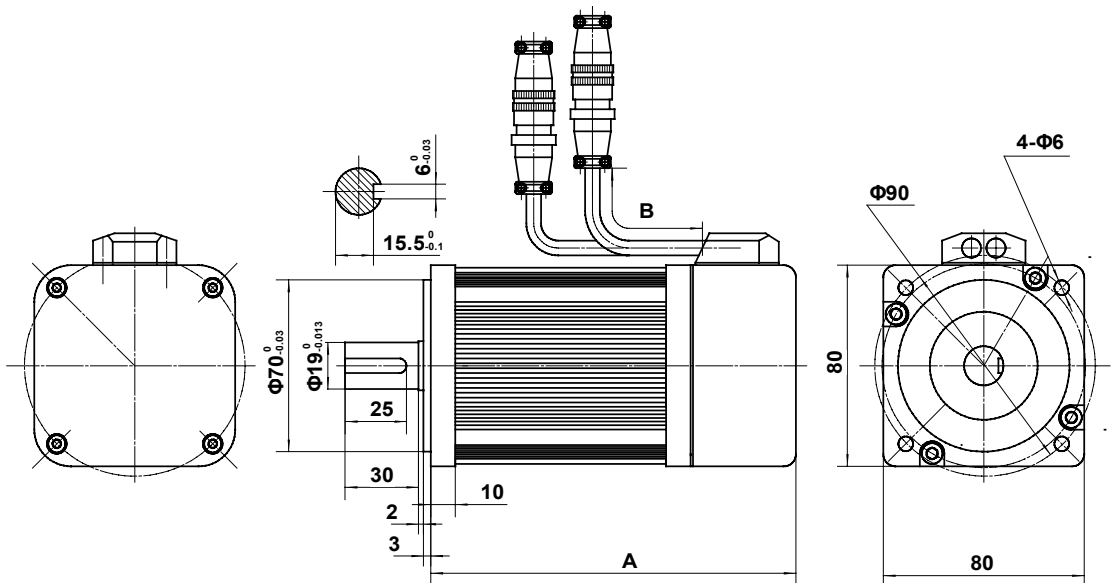

Rated torque (Nm)	1.3	2.4	3.3
A(mm)	128	150	165
B(mm)	500	500	500

7.7.2 Parameters of 110 series servo motor

Type	110ST-M02030L	110ST-M04030L	110ST-M05030L	110ST-M06020L	110ST-M06030L
Rated output power (kW)	0.6	1.2	1.5	1.2	1.6
Rated torque (Nm)	2	4	5	6	6
Rated speed(r/min)	3000	3000	3000	2000	3000
Rated current(A)	4.0	6.0	7.0	6.0	8.5
Rotor inertia (Kg·m ²)	0.425×10^{-3}	0.828×10^{-3}	0.915×10^{-3}	1.111×10^{-3}	1.111×10^{-3}
Weight (kg)	4.2	6.0	6.8	7.8	7.8
Line numbers of encoder	2500 line/pr				
Pole pair number	4 pair				
Insulation class	Class B				
IP rating	IP65				
Brake	Voltage: 24VDC(-15%~+10%), Current≤0.6A, Brake torque≥8Nm, Inertia: $0.64 \times 10^{-4} \text{kg} \cdot \text{m}^2$				

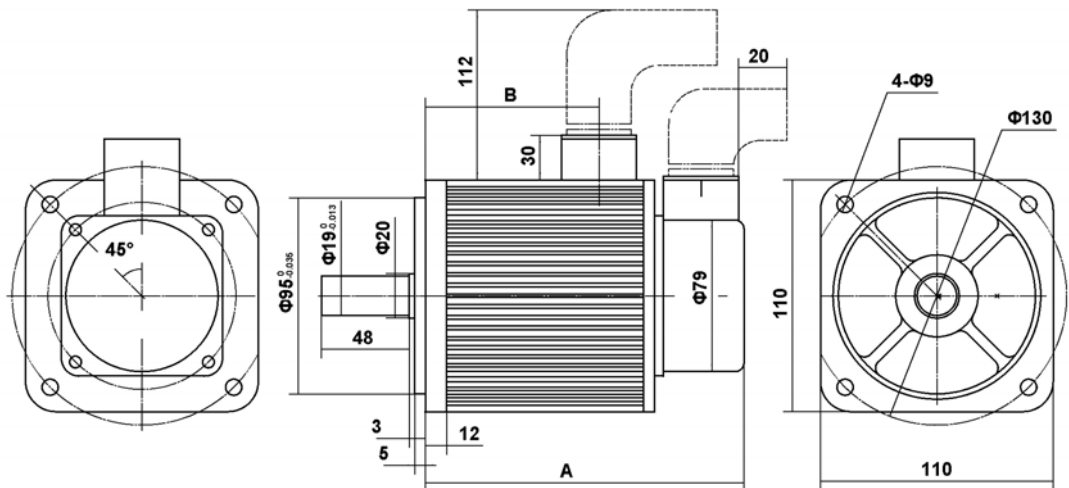

Rated torque (Nm)	2	4	5	6
A(mm) no brake	158	185	200	217
A(mm) with brake	200	227	242	259
B(mm)	76	102	118	134

7.7.3 Parameters of 130 series servo motor

Type	130ST-M04025L	130ST-M05020L	130ST-M05025L	130ST-M06025L
Rated output power (kW)	1.0	1.0	1.3	1.5
Rated torque (Nm)	4	5	5	6
Rated speed(r/min)	2500	2000	2500	2500
Rated current(A)	5.0	5.5	6.0	7.0
Rotor inertia (Kg·m ²)	1.101×10^{-3}	1.333×10^{-3}	1.333×10^{-3}	1.544×10^{-3}
Weight (kg)	6.0	6.9	6.9	7.6
Line numbers of encoder	2500 line/pr			
Pole pair number	4 pair			
Insulation class	Class B			
IP rating	IP65			
Brake	Voltage: 24VDC(-15%~+10%), Current≤0.6A, Brake torque≥12Nm, Inertia: 1.67×10^{-4} kg·m ²			

Type	130ST-M07720L	130ST-M07725L	130ST-M07730L	130ST-M10015L
Rated output power (kW)	1.6	2.0	2.4	1.5
Rated torque (Nm)	7.7	7.7	7.7	10
Rated speed(r/min)	2000	2500	3000	1500
Rated current(A)	6.5	8.5	10.5	6.5
Rotor inertia (Kg·m ²)	2.017×10^{-3}	2.017×10^{-3}	2.017×10^{-3}	2.595×10^{-3}
Weight (kg)	8.6	8.6	8.6	10.6
Line numbers of encoder	2500 line/pr			
Pole pair number	4 pair			
Insulation class	Class B			
IP rating	IP65			
Brake	Voltage: 24VDC(-15%~+10%), Current≤0.6A, Brake torque≥12Nm, Inertia: 1.67×10^{-4} kg·m ²			

Type	130ST-M10025L	130ST-M15015L	130ST-M15025L
Rated output power (kW)	2.6	2.3	3.9
Rated torque (Nm)	10	15	15
Rated speed(r/min)	2500	1500	2500
Rated current(A)	11.5	9.5	17.0
Rotor inertia (Kg·m ²)	2.595×10^{-3}	4.32×10^{-3}	4.32×10^{-3}
Weight (kg)	10.6	14.6	14.6
Line numbers of encoder	2500 line/pr		
Pole pair number	4 pair		
Insulation class	Class B		
IP rating	IP65		
Brake	Voltage: 24VDC(-15%~+10%), Current≤0.6A, Brake torque≥12Nm, Inertia: $1.67 \times 10^{-4} \text{kg} \cdot \text{m}^2$		

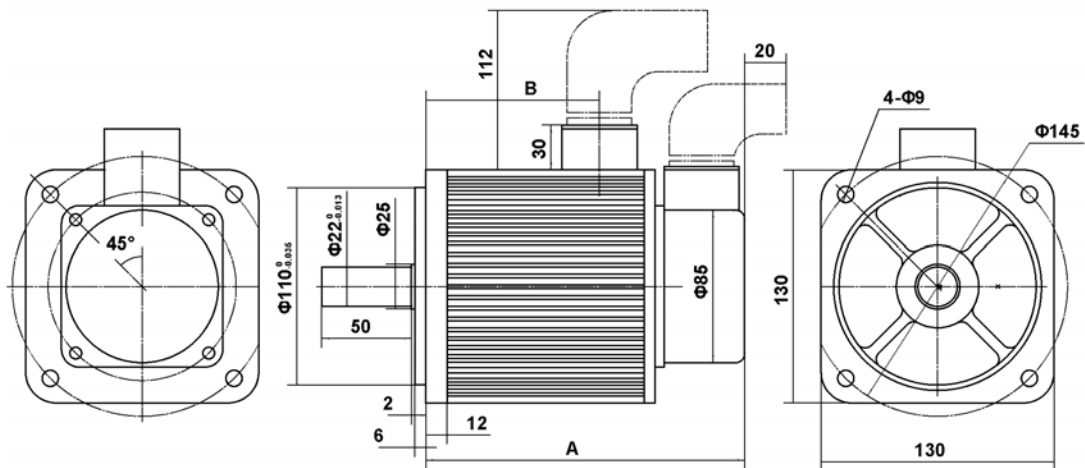

Rated torque (Nm)	4	5	6	7.7	10	15
A(mm) no brake	163	171	181	195	219	267
A(mm) with brake	205	213	223	237	261	309
B(mm)	80	89	98	112	136	184

7.7.4 Parameters of 150 series servo motor

Type	150ST-M15025	150ST-M18020	150ST-M23020	150ST-M27020
Rated output power (kW)	3.8	3.6	4.7	5.5
Rated torque (Nm)	15	18	23	27
Rated speed(r/min)	2500	2000	2000	2000
Rated current(A)	16.5	16.5	20.5	26.0
Rotor inertia (Kg·m ²)	6.15×10 ⁻³	6.33×10 ⁻³	8.94×10 ⁻³	11.19×10 ⁻³
Weight (kg)	15.7	17.8	21.4	23.7
Line numbers of encoder	2500 line/pr			
Pole pair number	4 pair			
Insulation class	Class B			
IP rating	IP65			
Brake	Voltage: 100VDC(-15%~+10%), Current≤0.4A, Brake torque≥30Nm, Inertia: 6×10 ⁻⁴ kg·m ²			

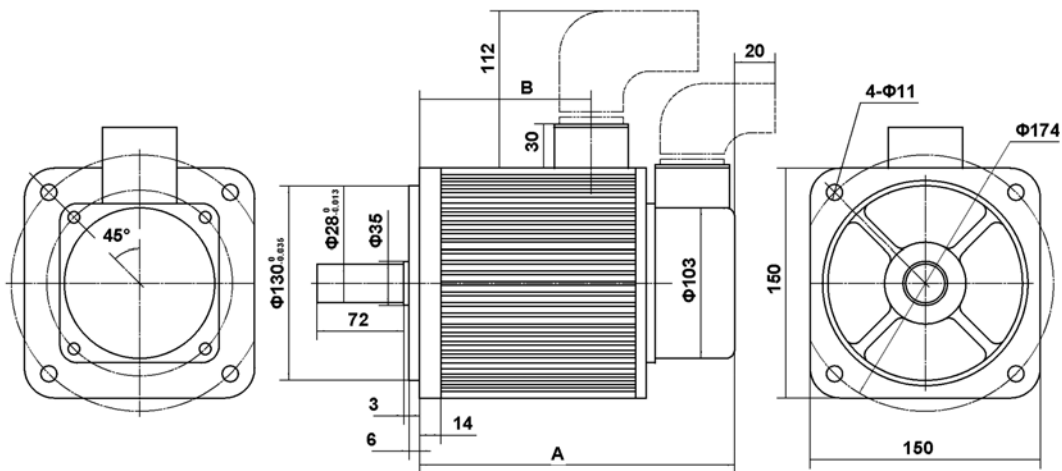

Rated torque (Nm)	15	18	23	27
A(mm) no brake	231	250	280	306
A(mm) with brake	293	312	342	368
B(mm)	146	166	196	222

Appendix A Model for SIEMENS CNC system

Because of the special interface of the SIEMENS 801、802S and 802C CNC system. A special type is provided for SIEMENS CNC system, and the Driver's suffix is S8. The hardware is different between the professional model and the standard model, so it can not replace each other. Attention should be paid when ordering.

Instead of standard DI interface, the special type servo driver have SIEMENS CNC system adapter. The DI function can not be used as usual, but enable input and DI1 input are multiplexing, the parameter P100 must be set to 1(SON). Other interfaces, including DO function、analog input、encoder signal output, can be used regularly.

A1 SIEMENS 801、802S CNC system

A1.1 Parameters setting

The parameter setting for the example:

parameter	Name	Setting value	Default value	Parameter explanation
P004	Control mode	0	0	Set position control
P097	Neglect inhibition of servo driver	3	3	Neglect CCW inhibition (CCWL) and CW inhibition (CWL)
P039	Filter mode of input command pulse	1	0	Close the numeral filters for the input signal SIGN, Request by the SIEMENS sequence.
P100	Digital input DI1 function	1	1	Set DI1 for servo enable (SON), enable input and DI input are multiplexing.

A1.2 SIEMENS 801、802S wiring diagram

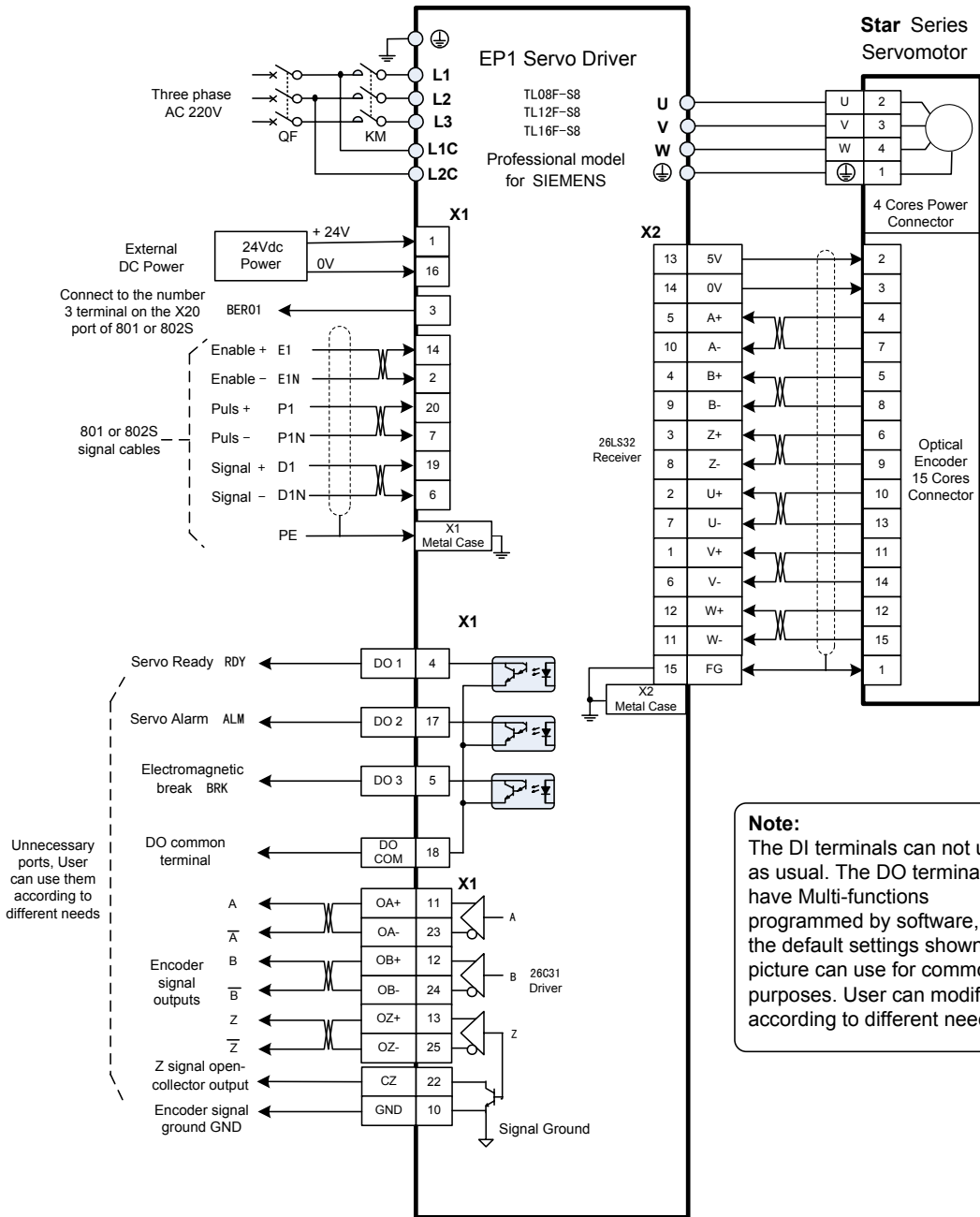

Edition antecedents

Edition number	Published time	Modify content
First edition	June,2009	

Maxsine Electric Co.,Ltd

(430223)East 3/F, Building 6, Jinqiao Industry
Garden, No.3 Zangliu Rd., Minzu Av., Donghu
Technical Development Zone, Wuhan, Hubei
PR China

Tel: 86-27-87921284, 87922796

Fax: 86-27-87921280

www.maxsine.com

June 2009

Published

Forbid strictly reprint and copy