



NEVO SERIES S-Track Interface



600 watt in the palm of your hand

The NEVO series are modular, user configurable power supplies offering unrivalled performance and flexibility. Our standard output modules offer voltages from 1.5V_{DC} to 58V_{DC} and can deliver up to 25A per module. The NEVO also offers customers the potential to connect output modules in series or parallel resulting in output voltages of up to 240V_{DC} and output currents of up to 100A at output powers of up to 600 watts. The flexibility of the NEVO power platform enables customers to configure solutions locally for almost any application.

Output modules 1 to 4 also come with full range analogue remote control of both voltage and current as standard and now with the release of the new S-Track Interface, multiple outputs which have been connected in series of the same module type can be easily controlled using a single control voltage.

Typically, the control of multiple outputs connected in series requires complicated circuitry to generate isolated control signals for each output module. Vox Power's new S-Track Interface plugs directly into each output module and provides a single analogue control bus for up to 4 modules of the same type which are connected in series.

A typical configuration is illustrated in the diagram opposite which shows four modules connected in series which are fully controllable through the S-Track Interface. However, two or three modules connected in series may also be controlled in the same manner.

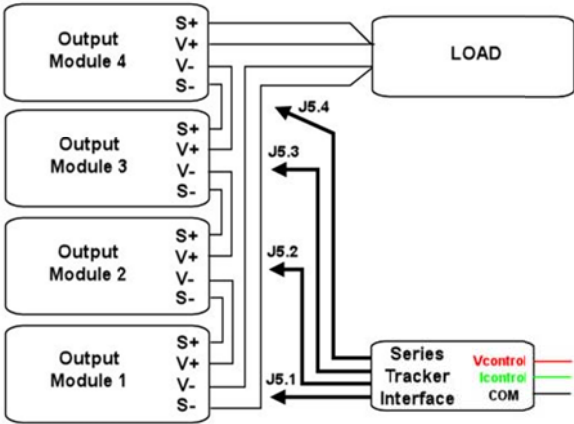

To control all modules connected in series the customer should connect the power and sense cables (connect S+/- if required) as shown in the example. Attach the signals connector (J5.x) to each module in the series chain. The shortest cable is connected to output module 1 which will be the reference module, next longest cable to module 2 and so on. When controlling less than 4 modules leave the remaining signal cables unconnected and program the S-Track Interface switch as described in the table.

Series Tracker Interface programming

Switch setting (1=ON, 0=OFF)		O/P's
1	2	
1	0	2
1	1	2
0	1	3
0	0	4

Note: Only modules of the same type should be connected in series and normal grounding precautions as described in the user manual should be observed. Incorrect grounding may result in damage to the unit. The S-Track Interface is not isolated and is referenced to the COM pin on J5 of the reference module i.e. first module in the series chain

Contact Vox Power for further assistance if necessary.

Ordering information – P/N: S - Track Interface

Vox Power Ltd. reserves the right to change or improve any part of the specification, electrical or mechanical design or manufacturing process without notice. Please consult your local distributor or contact Vox Power to ensure that you have the latest specification before using your product. For other information relating to the use of the product please refer to the latest NEVO user manual. Vox Power reserves the right to make changes without notice to any of its products. Vox Power does not assume any liability arising out of the use or application of any of its products and of any information to the maximum extent permitted by law. No license, express or implied, by estoppel or otherwise, to any intellectual property rights is granted by this document or by any conduct of Vox Power. VOX POWER DISCLAIMS ALL WARRANTIES AND REPRESENTATIONS. IN PARTICULAR ALL OTHER WARRANTIES, CONDITION OR TERMS RELATING TO SUITABILITY, FITNESS FOR PURPOSE, MECHANABILITY OR CONDITION OF THE PRODUCTS AND WHETHER EXPRESS OR IMPLIED BY STATURE OR COMMON LAW OR OTHERWISE ARE EXCLUDED.

Document DOC6010 rev 02