



## **FGD3 Flammable Sensor User Manual**

**Analox Ltd.**  
15 Ellerbeck Court, Stokesley Business Park  
North Yorkshire, TS9 5PT, UK  
T: +44 (0)1642 711400 F: +44 (0)1642 713900  
W: [www.analox.net](http://www.analox.net) E: [info@analox.net](mailto:info@analox.net)



## List of Contents

1	Introduction.....	1-3
1.1	Installation.....	1-3
1.1.1	Siting the sensors.....	1-3
1.1.2	Wire termination.....	1-3
1.1.3	Cable routing.....	1-3
1.1.4	Cable & screening.....	1-4
2	Installation in a non-hazardous location.....	2-5
2.1	Installation in a hazardous location.....	2-6
2.2	Installation using proprietary safety barriers.....	2-7
3	Menu mode selection.....	3-8
3.1	Zero sensor.....	3-9
3.2	Sensor span.....	3-9
3.3	Select FSD.....	3-10
3.4	Setting 4mA level.....	3-10
3.5	Setting 20mA level.....	3-11
3.6	Display mode.....	3-11
3.7	Display firmware version.....	3-11
3.8	Restore.....	3-12
3.9	View engineer/diagnostics data.....	3-12
3.10	Set cross reference.....	3-12
3.11	Positive zero suppression.....	3-13
3.12	Negative zero suppression.....	3-14
3.13	Set password.....	3-14
4	FGD3 head indications.....	4-15
4.1	Normal conditions.....	4-15
4.2	High gas conditions.....	4-15
4.3	Fault conditions.....	4-15
5	Sensor replacement.....	5-16
6	Certification.....	6-17
7	Mounting details.....	7-18
8	Declaration of conformity.....	8-19



## 1 Introduction

The detectors use the industry standard 4-20mA current loop to convey the gas levels detected to a control unit. This means that under zero gas conditions 4mA is drawn from the supply, and under full scale gas conditions 20mA is drawn from the supply. The current varies linearly for gas levels between zero and full scale.

The detector heads require a three-wire connection (see section 1.1.4). While the loop current supplies the power required by the detector head electronics within the detector head, a second supply must be provided to power the pellistor sensor and its associated circuitry.

### 1.1 Installation

#### 1.1.1 Siting the sensors

Mounting positions for sensors need to be considered individually, some points for consideration are:

- a) Ensure all sensors are mounted to allow routine calibration and maintenance to be carried out as required.
- b) Ensure the proposed site will not interfere with movement of existing equipment, e.g. cranes, doors etc.
- c) Install all cables neatly and securely.
- d) Sensors for detecting gases that are lighter than air should be positioned at a high level.
- e) Sensors for gases heavier than air should be located at below head height.
- f) Avoid siting the sensors adjacent to potential sources of radio frequency interference, e.g. radio transmitters, control switchgear, motors etc.

#### 1.1.2 Wire termination

All connections should be made according to the appropriate sensor or loop diagram for the configuration required. It is advised that 'bootlace ferrules' or 'flat blade crimps' be used for tidy and reliable connections of wires into the detector head connectors.

#### 1.1.3 Cable routing

Due to the low signal levels generated by gas detectors it is recommended that all wiring to the sensors be segregated away from AC mains or other high voltage/power lines to avoid interference.

## FGD3 Flammable Sensor User Manual

---

### 1.1.4 Cable & screening

The use of a screened cable is recommended for the installation of all detector heads. The correct strategy for connecting the screens depends upon the area in which the detector head is to be used (i.e. hazardous/ non-hazardous). In all cases the screen should not be connected at the detector head. Refer to the connection diagrams on the following pages for further information.

The FGD3 flammable detector head requires a three wire connection to the control unit:

Terminal	Function	Voltage / Current
Sig +	Current loop to head	8.0 to 28V (25mA max)
0	0V return to control unit	
+	Supply for sensor	4.0 to 7.0V (200mA approx)

## 2 Installation in a non-hazardous location.

When a detector head is installed in an area where there is no potential of an explosive gas hazard present, the cable lengths to the detector are limited solely by the resistance of the cable. The FGD3 gas detector requires a minimum of 8V between the Sig and 0- terminals to allow it to operate correctly.

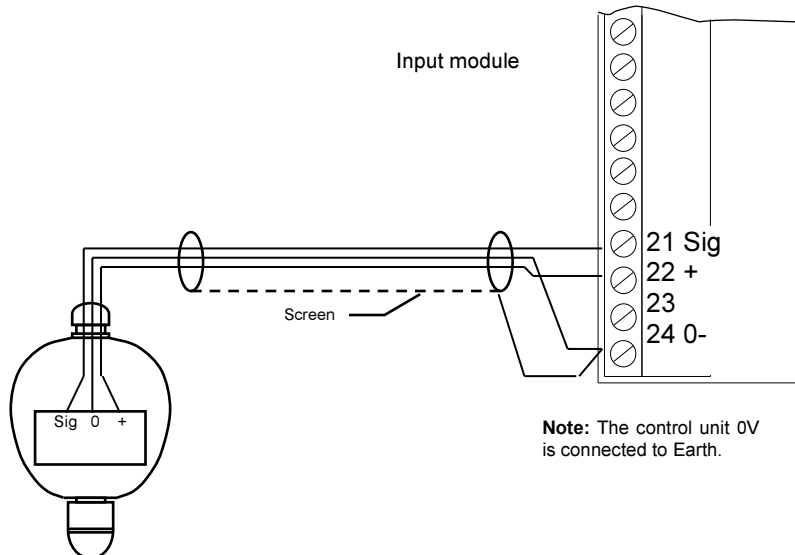

For systems operating at 24V, the maximum cable loop resistance is therefore  $(24-8)/25\text{mA}$  i.e.  $640\Omega$ .

The diagram above shows connections for FGD3 detector head in a non-hazardous location. The pin numbers shown at the control unit refer to pin numbers on the Analox Ltd input modules within the MCU control units. Refer to manufacturer if an alternative control unit is used.

**2.1 Installation in a hazardous location.**

When used in a hazardous area, the FGD3 detector requires an intrinsically safe (I.S.) power supply. This can be achieved by using proprietary safety barriers.

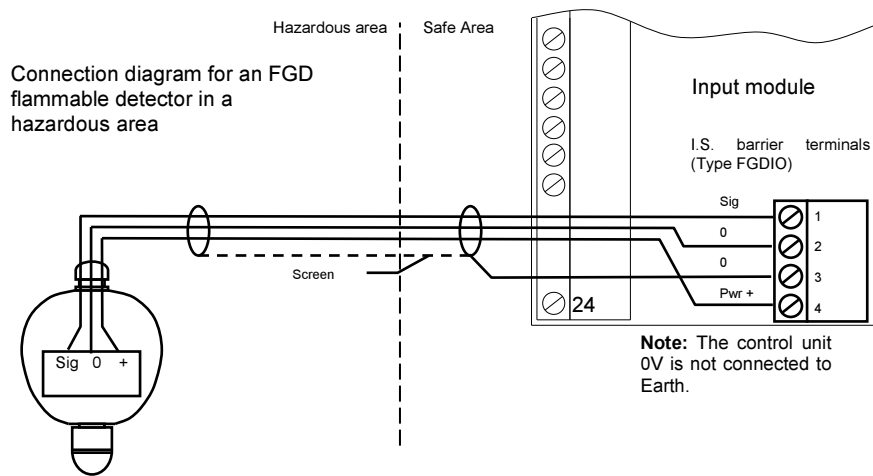

The use of barriers to create an I.S. supply imposes certain restrictions on the parameters of the interconnecting cables used. Consult the barrier manufacturer's data for further information.

Barriers must be selected to restrict the I.S. supply to the gas detectors within the following parameters:

Terminals	$U_{max}$	$I_{max}$	$P_{in}$	$C_i$	$L_i$
0V and SIG	30V	0.15A	0.81 W	10nF	0
0V and +	7.5V	0.75A	1.4W	9.7 $\mu$ F	0

When considering the capacitance and inductance allowable across the barrier output terminals, note:

There is 10nF and zero inductance between terminals 0V and SIG on the FGD3 detector head.

There is an equivalent of 9.7 $\mu$ F capacitance and zero inductance between terminals 0V and + on the FGD flammable gas detector.



## 2.2 Installation using proprietary safety barriers

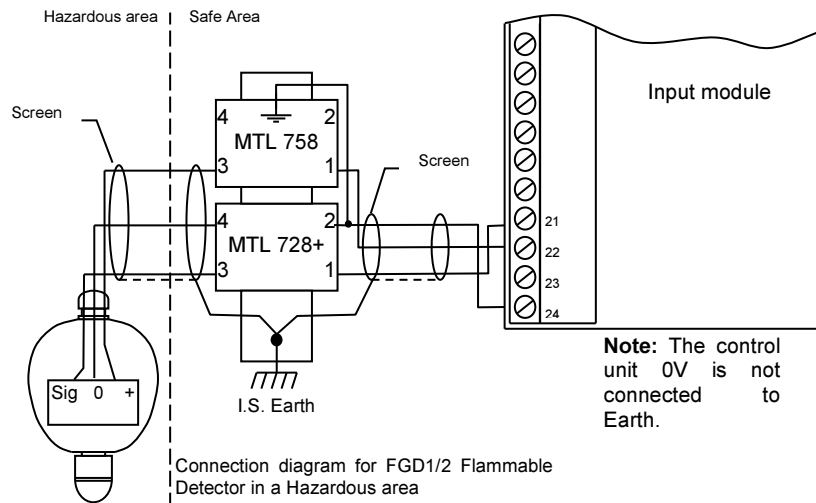

In order to maintain intrinsic safety, the capacitance and inductance or inductance to resistance (L/R) ratio of the loads connected to the terminals of the FGDIO barrier must not exceed specified values:

The capacitance and inductance or inductance to resistance (L/R) ratio of the load connected to terminals 1 and 2 must not exceed the following values:

GROUP	Capacitance in $\mu\text{F}$	Inductance in mH	OR	L/R Ratio in $\mu\text{H}/\text{ohm}$
IIC	0.083	3		44
IIB	0.65	12		177
IIA	2.15	25		355

The capacitance and inductance or inductance to resistance (L/R) ratio of the load connected to terminals 4 and 3 must not exceed the following values:

GROUP	Capacitance in $\mu\text{F}$	Inductance in mH	OR	L/R Ratio in $\mu\text{H}/\text{ohm}$
IIC	11.1	0.07		28
IIB	174	0.28		114
IIA	1000	0.56		228

### Warning:

When considering the suitability of an installation in terms of the load capacitance and inductance, account must be taken of the interconnecting cable itself. The figures in the tables must not be exceeded by the combination of the load parameters and the cable parameters. This may restrict the permissible cable length in some applications. If in doubt, consult AnaloX Ltd for assistance.

### **3 Menu mode selection**

In order to gain access to the menu switches and test points, release the screw situated between the letters A and T of the chrome STATUS label on the detector head front panel. The screw does not need to be completely removed, only release it far enough so that the STATUS label can rotate revealing the calibration switches and test points. The buttons and test points are designated as follows:

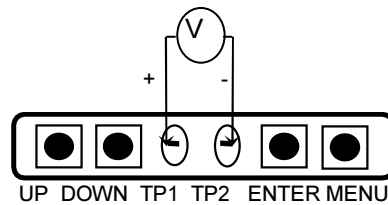

Several calibration modes exist in the detector head and these are accessible via the instruments simple menu system. To select a menu mode follow this procedure:

- Press the MENU button and **C: 1** appears on the display.
- Press UP or DOWN until the required menu mode is displayed on the screen.
- Press ENTER to select the menu mode.
- To exit the menu mode press MENU.

While the instrument is in a menu mode – any data displayed on the screen will alternate between the menu number and the reading.

The 'FGD' menu system is as follows: -

<b>Cal number</b>	<b>Function</b>	<b>Section</b>
<b>1</b>	Zero sensor	3.1
<b>2</b>	Sensor span	3.2
<b>3</b>	Select FSD	3.3
<b>4</b>	Setting 4mA level	3.4
<b>5</b>	Setting 20mA level	3.5
<b>6</b>	Display mode	3.6
<b>7</b>	Display firmware version	3.7
<b>8</b>	Restore	3.8
<b>9</b>	View engineer/diagnostics data	3.9
<b>12</b>	Set cross reference	3.10
<b>19</b>	Positive zero suppression	3.11
<b>20</b>	Negative zero suppression	3.12
<b>30</b>	Set password	3.13

### 3.1 Zero sensor

This calibration feature allows the instrument to determine the sensor output under zero gas conditions.

- Apply zero gas to the sensor inlet and allow enough time for the sensor to respond and all the gas to be purged (typically 2 minutes minimum dependent upon flow rate).
- Select menu mode **C: 1** and press ENTER.
- Press ENTER to perform the ZERO calibration.

**Note:**

Pressing MENU instead of ENTER aborts any changes (the existing ZERO factor will be displayed on exit).

- Press MENU – the display will show the ZERO factor for the instrument before returning to its standard mode of operation.

The ZERO factor should be recorded on any calibration certificates completed.

**Note:**

The two thermal conductivity sensors, CHTC & H2TC, have been characterised using nitrogen and as such must be zeroed in nitrogen.

### 3.2 Sensor span

This calibration feature allows the instrument to determine the sensor output when it is exposed to a known concentration of gas.

- Apply a known concentration of gas to the sensor inlet and allow enough time for the sensor to respond.
- Select menu mode **C: 2** (refer to section 3) and press ENTER.
- Using the UP and DOWN buttons, adjust the displayed reading so that it matches the calibration gas concentration.
- Press ENTER to perform the SPAN calibration.

**Note:**

Pressing MENU instead of ENTER aborts any changes (the existing SPAN factor will be displayed on exit).

- Press MENU – the display will show the SPAN factor for the instrument before returning to its standard mode of operation.

The SPAN factor should be recorded on any calibration certificates completed.

**Note:**

The two thermal conductivity sensors, CHTC & H2TC, have been characterised using nitrogen and as such must be calibrated with a CH<sub>4</sub> / H<sub>2</sub> gas balance nitrogen mix.

Typical gas levels are 50% of the range.

### **3.3 Select FSD**

The FSD value is usually matched to the sensor fitted. If the sensor is say a 0 to 100 %LEL sensor then the FSD is set to 100. It is possible to transmit a lower range on the 4 to 20 mA signal by reducing this value to say 50 %LEL.

This function does not affect the sensor calibration but does change the maximum reading that can be measured.

**Note:**

Changing this value outside the sensor's operating range may make the FGD unsuitable for its intended use.

- Select menu mode **C: 3** (refer to section 3) and press ENTER.
- Using the UP and DOWN buttons, adjust the displayed reading until the desired setting is displayed.
- Press ENTER to save the setting.

**Note:**

Pressing MENU instead of ENTER aborts any changes (the existing FSD factor will be displayed on exit).

- Press MENU – the display will show the sensor FSD for the instrument before returning to its standard mode of operation.

### **3.4 Setting 4mA level**

This calibration feature allows the instrument to simulate a condition of zero gas so that the 4mA output can be set.

- Attach a multimeter (set to measure DC voltage) between test points TP1 and TP2.
- Select menu mode **C: 4** (refer to section 3) and press ENTER.
- Using the UP and DOWN buttons, adjust the reading displayed on the multimeter to 40mV  $\pm$ 0.5mV
- Press ENTER to store the 4mA calibration data.

**Note:**

Pressing MENU instead of ENTER aborts any changes (the existing DAC 4mA factor will be displayed on exit).

- Press MENU – the display will show the DAC 4mA calibration factor for the instrument before returning to its standard mode of operation.

### 3.5 Setting 20mA level

This calibration feature allows the instrument to simulate a condition of full-scale gas so that the 20mA output can be set. A control unit connected will indicate full-scale gas also and may enter its alarm state.

- Attach a multimeter (set to measure DC voltage) between test points TP1 and TP2.
- Select menu mode **C: 5** (refer to section 3) and press ENTER.
- Using the UP and DOWN buttons, adjust the reading displayed on the multimeter to 200mV  $\pm$ 0.5mV
- Press ENTER to store the 20mA calibration data.

**Note:**

Pressing MENU instead of ENTER aborts any changes (the existing DAC 20mA factor will be displayed on exit).

- Press MENU – the display will show the DAC 20mA calibration factor for the instrument before returning to its standard mode of operation.

### 3.6 Display mode

- Select menu mode **C: 6** (refer to section 3) and press ENTER.
- Use the UP and DOWN button to move the decimal point to the desired setting.
- Press ENTER to set the display mode.

**Note:**

Pressing MENU instead of ENTER aborts any changes (the existing display mode will be displayed on exit).

- Press MENU to return the instrument to its standard mode of operation.

**Note:**

Changing the decimal point will not result in a more accurate reading.

### 3.7 Display firmware version

The firmware version is displayed as part of the start up procedure but can be viewed without powering down the instrument via menu option 7.

- Select menu mode **C: 7** (refer to section 3) and press ENTER.
- The display will show the firmware version number.
- Press MENU to return the instrument to its standard mode of operation.

### **3.8 Restore**

The firmware for the detector head is common to infrared CO<sub>2</sub>, HC, pellistor, oxygen and toxic instruments. This feature allows the type of sensor fitted to be selected.

- Select menu mode **C: 8** (refer to section 3) and press ENTER.
- Press ENTER to restore the factory default settings.

**Note:**

Pressing MENU instead of ENTER aborts any changes (the existing sensor data is left intact).

- Press MENU to return the instrument to its standard mode of operation.

<b>Sensor type</b>	<b>Range</b>	<b>display</b>
PELL	0-100%LEL	0 - 100
CHTC	0-100%Volume CH4	0 - 100
H2TC	0-100%Volume H2	0 - 100

This feature will erase all the configuration settings of the detector head and replace them with the instruments default values for the sensor selected. Following the use of this feature the instrument must have a full calibration (including the 4-20mA loop).

### **3.9 View engineer/diagnostics data**

This feature is a view-only feature. No configuration changes are possible from within this menu.

This information is for the use of Analox Ltd.

- Select menu mode **C: 9** (refer to section 3) and press ENTER. The display will alternate between the current value and code **C: 9x**: where x is:
  - 0 Sensor reading.
  - 4 Detector A to D counts.
- The mode of operation can be selected by pressing the UP button.
- Press MENU to return the instrument to its standard mode of operation.

**Note:**

The diagnostic structure is compatible with other gas types and as such certain features are not available, N/A.

### **3.10 Set cross reference**

**Menu mode C: 12**

This option is used to allow the user to calibrate the sensor with a commonly available gas (e.g. methane or propane) but use the unit to detect a different gas (e.g. methanol or acetone etc.). This is achieved by adjusting the cross-reference factor according to the difference in signal that is detected for the calibration gas compared to the target gas.

- Press MENU to open the menu system.
- Select menu mode **C:12** (refer to section 3) and press ENTER.
- Press ENTER.

- Using the INCREASE and DECREASE buttons, set the required cross-reference factor.
- Press ENTER to store the new value.

**Note:**

Pressing MENU instead of ENTER aborts any changes (the existing factor is displayed on exit).

- Press MENU to close the menu system.

**Ask Analox Ltd for advice on settings.**

Some typical settings for methane calibration gas

Target gas	Xref	Comments
Methane	1.00	
Propane	1.88	
Butane	2.04	
Hexane	2.35	
Ethane	1.39	
Pentane	2.21	
Nonane	4.00	
Acetylene	1.67	
Acetone	2.21	
Xylene	3.00	
MEK	2.63	

**Note:**

The cross reference signal is not suitable for either of the two thermal conductivity sensors, CHTC & H2TC, and as such must be set to 1.00.

**3.11 Positive zero suppression**

This option is used to allow the user to suppress small amounts of positive sensor zero drift. The setting can be set between 0 and 10% of the sensor range as set by the FSD value.

- Press MENU to open the menu system.
- Using the NEXT and PREVIOUS buttons, select menu option: **C:19**
- Press ENTER.
- Using the INCREASE and DECREASE buttons, set the required zero suppression value.
- Press ENTER to store the new value.

**Note:**

Pressing MENU instead of ENTER aborts any changes (the existing suppression level is displayed on exit).

- Press MENU to close the menu system.

### **3.12 Negative zero suppression**

This option is used to allow the user to suppress small amounts of negative sensor zero drift. The setting can be set between 0 and 10% of the sensor range as set by the FSD value.

- Press MENU to open the menu system.
- Using the NEXT and PREVIOUS buttons, select menu option: **C:20**
- Press ENTER.
- Using the INCREASE and DECREASE buttons, set the required zero suppression value.
- Press ENTER to store the new value.

**Note:**

Pressing MENU instead of ENTER aborts any changes (the existing suppression level is be displayed on exit).

- Press MENU to close the menu system.

### **3.13 Set password**

Use this menu option to enable / disable the password feature.  
Place the FGD in the password menu as follows:

- Press the MENU to open the menu system.
- Using the NEXT and PREVIOUS buttons, select menu option: **C:30**

**Note:**

If the password system is already enabled the user must enter the 6-digit password to get to this menu.

- Press ENTER.
- The display shows either **On** or **OFF**
- Press the UP button to select the desired setting.
- Press ENTER to accept the setting.

**Note:**

Pressing MENU instead of ENTER leaves the unit without change.

Press MENU to return the instrument to its standard mode of operation.

**Note:**

If the password is in operation then the user will be prompted with PASS when ever the menu key is pressed. Pressing the MENU key again will result in the restricted user access, i.e. only the zero and span options will be available. Entering the correct password will give access to the full menu facility.



## 4 FGD3 head indications

### 4.1 Normal conditions

The FGD3 gas detector head will display a steady reading for gas levels between 0 and FSD.

### 4.2 High gas conditions

The FGD3 gas detector head will flash between the gas reading and 'Hi ' when the gas reading is above the sensor FSD. This will coincide with the head drawing a current of 20 - 25mA from the control unit, thus ensuring the control unit is aware of the high condition.

### 4.3 Fault conditions

The FGD3 gas detector head will flash between 'F xx' and the gas reading when the reading falls below -10% of the sensor FSD. This will coincide with the head drawing a current of less than 2.5mA from the control unit, thus ensuring the control unit is aware of the fault condition.

#### Note 1:

xx is a number that defines a particular fault as follows:

- 1 Checksum error.
- 2 Zero calibration error.
- 4 Span calibration error.
- 8 Sensor reference low output.
- 16 Sensor reference high output.
- 32 Sensor detector low output.
- 64 Sensor detector high output.

#### Note 2:

There may be more than one fault i.e. F 6. The above fault numbers are simply added together, thus:

Sensor requires zero calibration F2

Sensor requires zero calibration F4

## **5 Sensor replacement**

**Note:**

Applies only to instruments fitted with an integral sensor.

- a) Inhibit the channel at the control unit.
- b) Disconnect power to the head at the control unit.
- c) Release the sensor retainer.
- d) Unplug the sensor from the PCB.
- e) Push the new sensor into the PCB, making sure of the pin alignment.
- f) Refit the sensor retainer.
- g) Allow the sensor to stabilise for 1 to 2 hours prior to calibration.
- h) Calibrate the detector head.
- i) Enable the channel at the control unit.

## 6 Certification

The FGD3 flammable gas detectors carry the following markings:

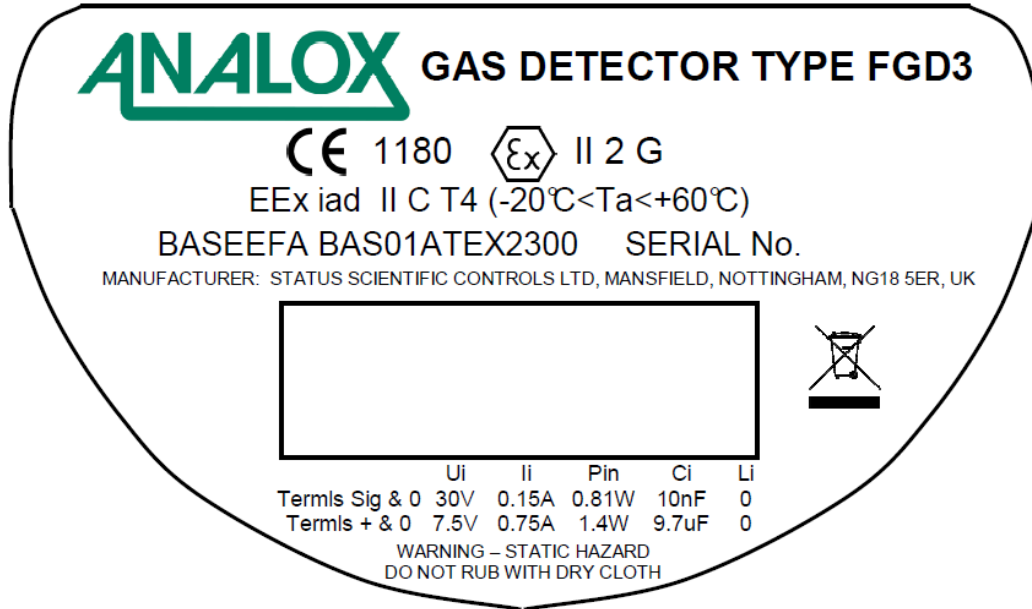

## **7 Mounting details**

The diagram below shows the mounting centres for the FGD3 detector head enclosure.

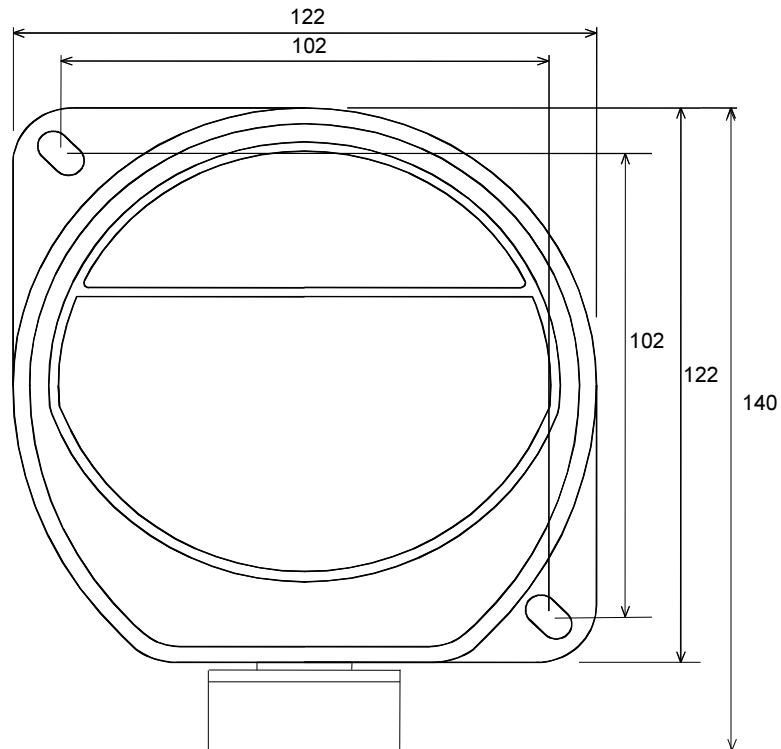

Depth = 75mm approx

**Note:**

The front panel/lid of the detector head opens to allow access to the screw terminals situated inside. Sufficient space should be allowed around the mounting position so that this action is not restricted.

**Fixings required:**

2 off M6 Fasteners

(Rawl bolts or similar dependent on mounting wall construction)

## 8 Declaration of conformity

We declare that, on the date the equipment accompanied by this declaration is placed on the market, the equipment conforms with all technical and regulatory requirements of the directives listed below.

<p><b>Description of Equipment:</b></p> <p>The FGD1-3 Series of Fixed Gas Detectors for the detection of Oxygen, Toxic or Flammable gases.</p> <p>ATEX Certified intrinsically safe for use in Group IIC hazardous locations.</p>
---

### Directive 94/9/EC ATEX

<p><b>Standards Used:</b></p> <p><b>EN50014:1997 + Amds 1 &amp; 2</b> Electrical apparatus for potentially explosive atmospheres -General requirements.  <b>EN50020:1994</b> Electrical apparatus for potentially explosive atmospheres -Intrinsic safety 'I'.  <b>EN50018:2000</b> Electrical apparatus for potentially explosive atmospheres -Flameproof enclosure 'd'.</p>	
<p><b>Notified Body for Hazardous Area Certification:</b></p> <p>Baseefa          Rockhead Business Park          Staden Lane, Buxton SK17 9RZ, UK          Notified Body Number : 1180</p>	<p><b>Notified Body for ATEX Quality Assurance Notification:</b></p> <p>Baseefa          Rockhead Business Park          Staden Lane, Buxton SK17 9RZ, UK          Notified Body Number : 1180</p>
<p><b>Hazardous Area Certificate Number:</b></p> <p>Baseefa 01ATEX2300  II 2 G EEx ia IIC          T4 (-20° C &lt;Ta&lt; +60° C)</p>	<p><b>ATEX Quality Assurance Notification Number:</b></p> <p>2056</p>
<p><b>Place of Manufacture:</b></p> <p>Mansfield, Nottinghamshire, UK.      Date mark applied – see product</p>	<p><b>ISO 9001:2008 Quality Management System:</b></p> <p>Certificate No. GB93/1938</p>

### 2004/108/EC – Electromagnetic Compatibility

<p><b>Harmonised Standards Used:</b></p> <p><b>EN50270:2006</b> Electromagnetic compatibility - Electrical apparatus for the detection and measurement of combustible gases, toxic gases or oxygen.</p>
---

Authorised Signatory to this declaration, on behalf of the manufacturer:

Name:                                      W. R. Baxter                                      Title:                                      Managing Director

Address:                                      Status Scientific Controls Ltd, Hermitage Lane Industrial Estate, Kings Mill Way  
 Mansfield, Nottinghamshire, NG18 5ER, United Kingdom

Signature                                                                            Date:                                      15.04.11.



