

PROGRAMMABLE MAGNETIC BIKE USER'S MANUAL

GB

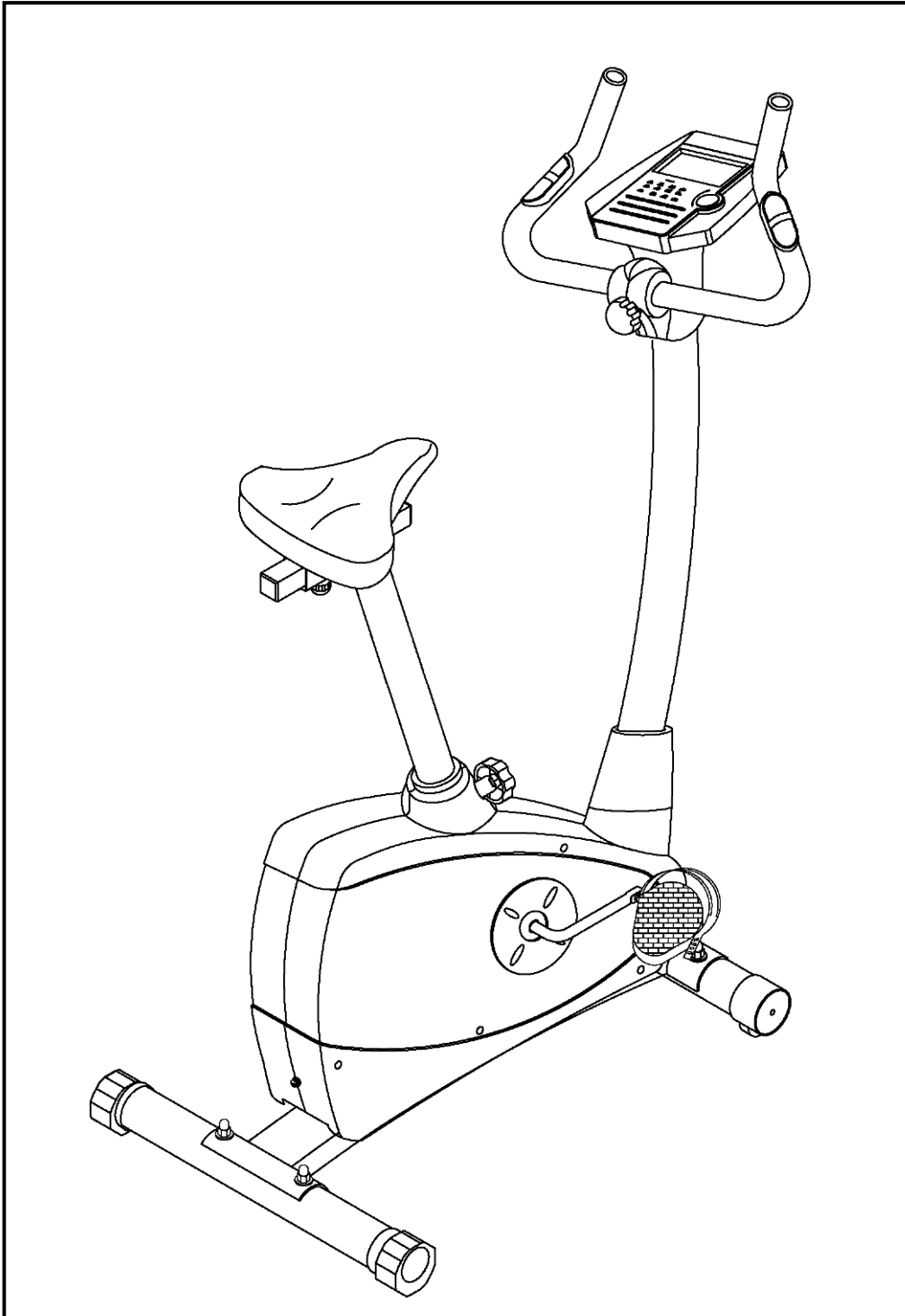

This quality products is designed, manufactured, tested and certified for enhanced Fitness Training.

Dear Customer,

We want to thank you for having chosen a programmable MAGNETIC BIKE product and wish you a lot of fun and success during training.

Please note and follow the enclosed safety and assembly instructions carefully.

If you have questions please do not hesitate to contact us.

Table of Content:

1. Safety Instructions	P. 2
2. Hardware Package	P. 3
3. Assembly Instructions	P. 4
4. Computer Instructions.....	P. 6
5. Training Instructions	P.10
6. Exploded Drawing	P.11
7. Parts List	P.12
8. Training pulse rate.....	P.14

Safety Instructions



Before you start training on your home PROGRAMMABLE MAGNETIC BIKE, please read the instructions carefully. Be sure to keep the instructions for information, in case of repair and for spare part delivery.

- The HM-6004M is made for home use only and tested up to a max. body weight of 100 kg.
- Follow the steps of the assembly instructions carefully.
- Use only original parts as delivered.
- For assembly use only suitable tools and ask for assistance with assembly if necessary.
- Place the bike on an even, non-slippery surface. Because of possible corrosion, the usage of the home exercise bikes in moist areas is not recommended.
- Check before the first training and every 1-2 months that all connecting elements are tight fitting and are in the correct condition.
Replace defective components immediately and/or keep the equipment out of use until repair.
For repairs, use only original spare parts.
- In case of repair please ask your dealer for advice
- Avoid the use of aggressive detergents when cleaning the home exerciser.
- Ensure that training starts only after correct assembly and inspection of the item.
- For all adjustable parts be aware of the maximum positions to which they can be adjusted/tightened to.
- The home exerciser is designed for adults. Please ensure that children use it only under the supervision of an adult.
- Ensure that those present are aware of possible hazards, e.g. movable parts during training.
- Consult your physician before starting with any exercise programme. He can advise on the kind of training and which impact is suitable.
Warning: incorrect/excessive training can cause health injuries.
- Please follow the advice for correct training as detailed in training instructions.
- The load/work level can be adjusted by turning the up/down knob on the computer.

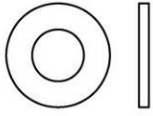

8*16*1.5mm (#23) *4

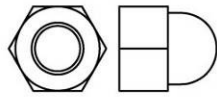

M8 (#22) *4

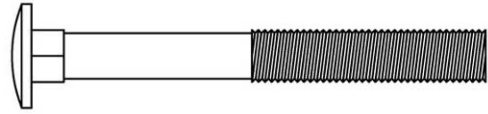

M8*70mm (#21) *4

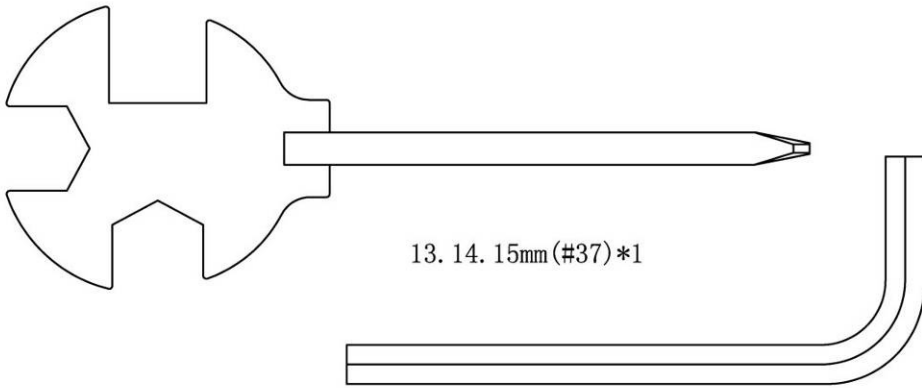

13. 14. 15mm (#37) *1

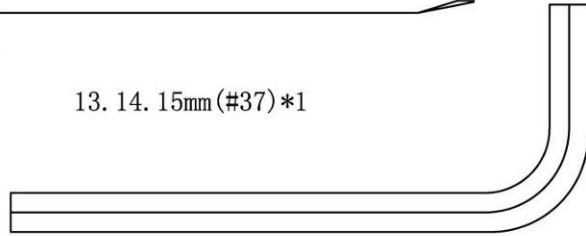

6mm (#38) *1

Assembly Instruction

GB

Step 1

GB

1. Fasten front stabilizer (2) and rear stabilizers (3) each with 2 carriage bolts (21) from the underside of stabilizers. Secure with 2 washers (23) & domed nuts (22) to main frame (1).

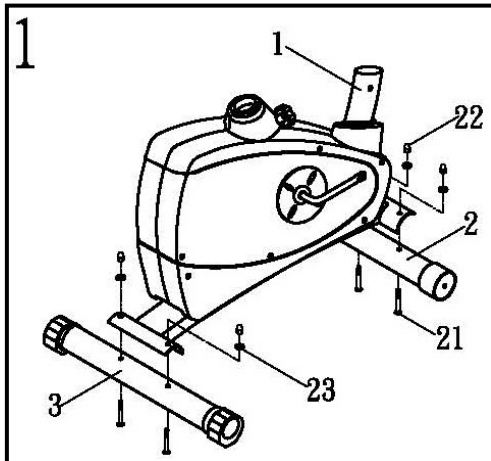

Step 3

GB

1. Unscrew the pre-assembled 4 hex. Bolts (24) & 4 washers (25).
2. Connect the upper computer cable (18) with lower computer cable (19) tightly.
3. Put the handlebar post (4) into the main frame (1). Secure with 4 hex. Bolts (24) & 4 washers (25) tightly.

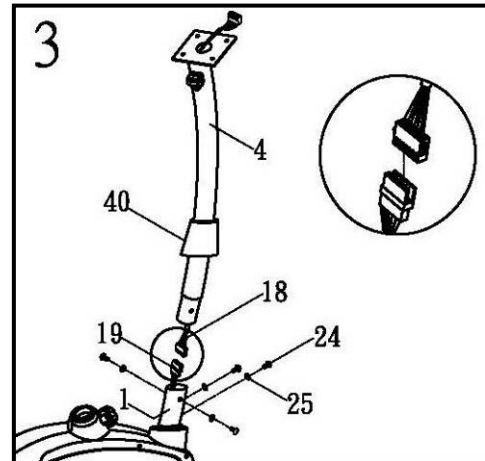

Step 2

GB

2. Screw pedal (26) onto the crank arm set (39). The pedals are marked with R and L at the screw. Tighten the left pedal counter-clockwise, the right pedal clockwise.

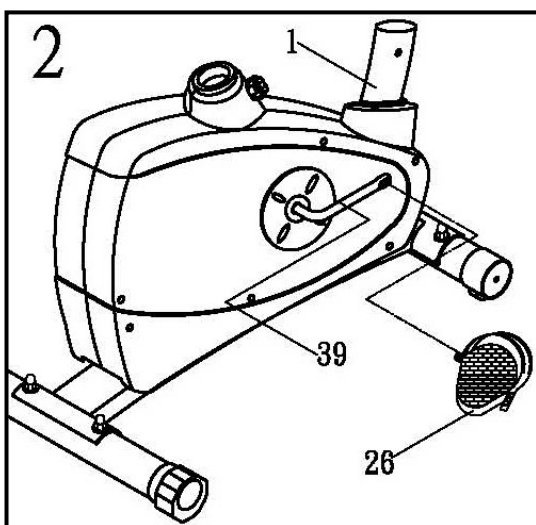

Step 4

GB

1. Release round knob (11) and sleeve (14) from fastener at handlebar post (4). Open up fastener and place the handlebar (31) onto fastener.
2. Select the desired position for handlebar (31), fasten the fastener by round knob (11) with sleeve (14) securely.

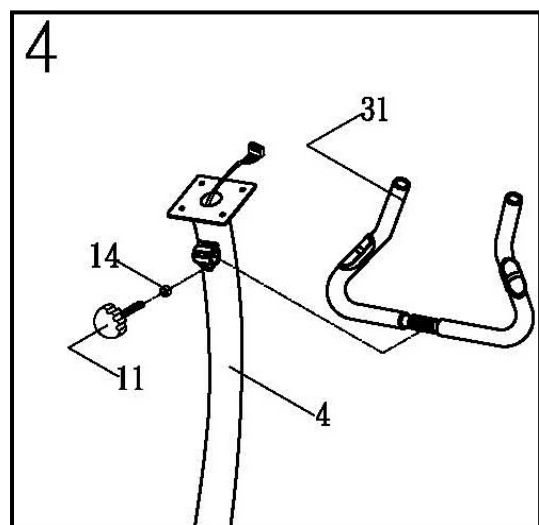

Step 5

(GB)

1. Plug the upper computer cable (18) to jack at back of computer (20). Slide computer (20) to the bracket at the top of handlebar post (4), secure with 4 screw (47) firmly.
2. Plug the hand pulse sensor wire (42) to jack at back of computer (20).

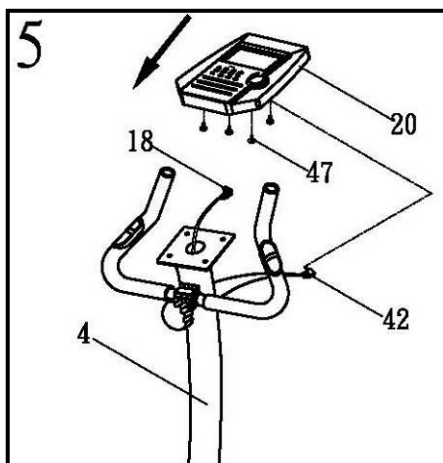

Step 7

(GB)

1. Attach saddle adjustable post (6) to saddle (7), secure with 3 x washer (45) and 3x locknut (44).
2. Release the knob (10) from saddle post (5). Put saddle adjustable post (6) into saddle post (5). Select the desired position and fasten with knob (10).

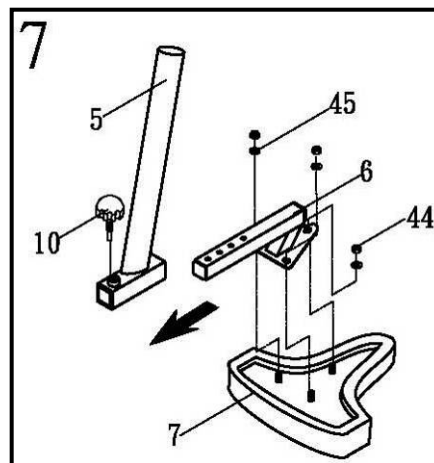

Step 6

(GB)

1. Attach right and left plastic computer holder (30) to handlebar post (4) (under handlebar (31)). Secure with 4 bolts (52) firmly.

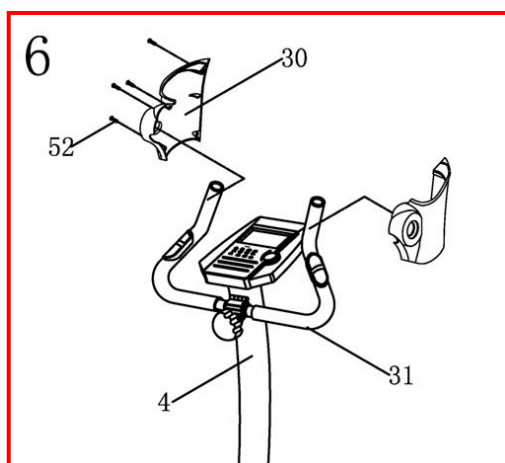

Step 8

(GB)

1. Loosen & pull the saddle post knob (13). Insert the saddle post (5) to the main frame (1), choose the desired position and tighten the Saddle post knob (13) again.
2. Attach adaptor (49) to DC wire (48) at back of main frame (1).
3. Ensure that the knob is always tightened.

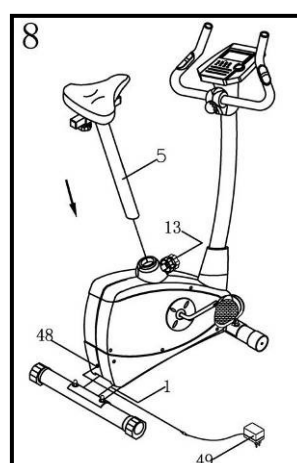

Programable Training Computer - SM3105-20

Initial operating process: (After the computer is power on with adaptor installed)

- Step One** You may use UP or DOWN to select training mode in MANUAL or PROGRAM (12 different profiles) or USER or TARGET HEART RATE control (4 different options for training). If you select training with Target Heart Rate control mode, you need to input AGE data, and switch to next procedure.
- Step Two** You may use UP or DOWN to adjust the training LOAD/DIFFICULTY level from 1 to 16 under MANUAL, PROGRAM and USER mode .(Exclude TARGET HEART RATE CONTROL mode)
- Step Three** You may use UP or DOWN to preset training function datas, when each function data has been preset, press ENTER.
- Available preset training functions:
- TIME: Preset area is from 00:00 to 99:00, each increment is 1:00 (minute).
- DISTANCE: Preset area is from 0.00 to 99.90, each increment is 0.10 km or ml.
- CALORIE: Preset area is from 0 to 990, each increment is 10 cal.
- WATT: Preset area is from 10 to 350, each increment is 10 watt.
(WATT can be preset under MANUAL mode only)
- PULSE: Preset area is form 30 to 240, each increment is 1 BPM.
(Exclude in TARGET H.R control mode)
- Step Five** Press START/STOP button to start training.

Training Mode Instruction:

To start your training :

As soon as you press START/STOP button without any presetting (functions and programs), the computer starts working under Manual mode.

Training without preset Time:

If you do not preset TIME,each unit of the profile switches forth to another per 0.1 km or ml in counting up (no preset DISTANCE) or counting down (has preset DISTANCE).

Training with preset Time:

If you have preset TIME,each unit of the profiles switches forth to another per preset TIME divided by 16.

Tension difficulty adjustment:

You may adjust the tension load from 1 to 16 during training under Manual mode if you did not preset Watt function.

If you have preset WATT, tension load will be auto-adjusted depends on the current speed and watt values you are working out.

There will be four different symbols shows up to help your training:



You need to slow down the training speed.



You need to speed up the training.

----- This is to remind the current WATT is OVER SPEC, and you need to speed up or slow down training speed accordingly.

** When the WATT is over spec, computer has Bi-Bi-Bi/second to remind you. If you keep training under this mode for over 3 minutes, the computer has an ALARM with 6 beeps sounds for 30 seconds, and the computer system STOP automatically, at this moment, LOAD is down to 1, and preset WATT data is zero. During the ALARM period, you can stop ALARM by pressing any function buttons.

Training with 12 profiles - You can select from P1 to P12 profiles for training, also you can adjust training levels any time during training.

Training with USER - You can preset your personal training profiles under this mode. During training, you can also adjust training levels any time.

Training in TARGET H.R. control - The tension difficulty will be auto-adjusted according to the current heart rate figure. If your heart rate figure is under the target pulse, the tension difficulty will be up-adjusted one level per 30 seconds, up to the maximum level 16. As soon as your heart rate figure is achieved at the target pulse, tension difficult will be down adjusted one level immediately, and keep down-adjusted one level per 15 seconds until level 1. If your current heart rate is still over (or equal to) the target pulse for 30 seconds when tension is level 1, the computer system will STOP and ALARM for 6 beeps to remind you as the training protection.

You may select fixed preset target heart rate percentage or input your personal training target heart rate figures.

Target Pulse with different percentage selected -

You may use UP or DOWN to have the TARGET HEART RATE figure be zero, and press ENTER button. At this moment, you may select the percentage of the heart rate that you will achieve in the training. The computer provides 3 different percentage of the maximum heart rate which is calculated by the CPU according to the AGE data you inputed.

Remark: 55%MAXH.R. - If you input age in 30, the figure will be 104, this figure is 55% of the max. heart rate figure which is 190, the proper figure calculated by the CPU compared the age of 30. The same formula can be used to have the result for 75%, and 90%.

Target Pulse figure input by yourself -

You may preset your target pulse figure by pressing UP and DOWN buttons. As soon as you have preset the target pulse figure, the level will be fixed on level 1, and you may only start training from level 1. When your actual heart rate has reached over the target, the computer starts to alarm to remind you, and it stops when your heart rate comes under the target.

To stop your training:

Training with PRESET function datas:

As soon as the preset function datas counting down to zero, (pulse figures excluded) the computer has 8 beep sounds and remind you. At this moment, the computer will stop working. You may press START/STOP button to start the computer working and counting up from the previous datas.

Interrupt training:

You may press START/STOP button to stop computer working during training any time.

To reset program:

You may press RESET button to reset the PROGRAM and select the training mode and tension load or difficulties under STOP mode. If you hold on pressing the RESET button for 2 seconds, all datas(including personal datas) will be total reset.

Buttons:

ST/STOP	To start or stop training.
ENTER	To select each function of Time, Distance, Pulse, Watt for presetting.
ENCODER UP	To up adjust datas.
ENCODER DOWN	To down adjust datas.
RESET	1. To reset each function of Time, Distance, Pulse, Watt function figures. 2. To reset program setting and back to initial selection mode with Manual, Program, user, or Target Heart Rate all blinking display.
RECOVERY	To have pulse recovery function work.

Functions:

TIME	Count Up - The computer starts counting up from 00:00 up to 99:59 during training. Count Down - The computer will count down from the preset Time to 00:00.
SPEED	Displays the current SPEED from 0.0 to maximum 99.9 km or ml.
DISTANCE	Count Up - The computer accumulates total workout distance from 0.00 to the max. 99.90 km or ml during training. Count Down - The computer will count down from the preset Distance to 0.00.
CALORIES	Count Up- The computer accumulates the calories consumption from 0 to the max. 990 cal during training. Count Down - The computer will count down from the preset Calories to 0. This data is a rough guide for comparison of different exercise sessions that can not be used for medical treatment.
PULSE	The monitor can detect your handpulse. You may preset target pulse between 30 to 240 bpm to assist the training. The options you may have are as the following: Alarm - If you preset the target pulse under training with Manual or other target the computer will alarm to remind as soon as your current heart rate is achieved at the preset figure. Load tension adjustment - If you preset the target heart rate (or select different target heart rate percentage), the load resistance will be auto-adjusted according to your actual heart rate figure compared with the preset heart rate which is heart rate control program.
RECOVERY	After exercising for a period of time, keep holding on grips and press " RECOVERY" button, all function display will stop except "Time". Time starts counting down from 00:60 - 00:59 - 00:58 - to 00:00. As soon as 00:00 is reached, the bottom area of LCD will show your heart rate recovery status with the grade F1, F2,... F6. F1 is the

best, and F6 is the worst. You may keep exercising to improve the heart rate recovery status day by day from F6 up to F1.

** Press the RECOVERY button again to return the main display.

WATT

After training for a while, the monitor will display current workout watt.

Note:

1. When there is no signal been transferred into the computer for 4 minutes, the LCD display will shutt off automatically, and all previous training datas will be stored. You may press any button to have the computer restart working.
2. The monitor has the same result as abovementioned point 2 if you press and hold on RESET button for 4 seconds.
3. If the LCD display is improper, please remove the power connection and connect it again.
4. The monitor can be power on with an AC adaptor input (500mA, 6V)



To achieve a considerable improvement of your physical resistance and your health, some aspects of how to find the most efficient amount of training should be followed:

If you have not been physically active for a longer period of time and also to avoid health risks you should consult your general physician before starting to exercise.

Intensity

To achieve maximum results the right intensity has to be chosen.

The heart rate is used as guideline.

As a rule of thumb the following formula is commonly used:

Maximum pulse rate = 220 - Age

While exercising the pulse rate should always be between 60% - 85% of the maximum pulse rate.

For your personal training rates please see the attached pulse rate chart on page 14.

When starting to exercise you should keep your rate at 60% of your maximum pulse rate in the first couple of weeks.

With increasing improvement of fitness the pulse rate should be slowly increased to 85% of your maximum pulse rate.

Fat burning

The body starts to burn fat at approx. 60% of the maximum pulse rate.

To reach an optimum at burning rate, it is advisable to keep the pulse rate between 60% – 70% of the maximum pulse rate.

The optimum training amount consists of three workouts per week 30 minutes each.

Example:

You are 52 years of age and would like to start exercising.

Maximum pulse rate = $220 - 52(\text{age}) = 168$ pulse/min

Minimum pulse rate = $168 \times 0.6 = 101$ pulse/min

Highest pulse rate = $168 \times 0.7 = 117$ pulse/min

During the first weeks it is advisable to start with a pulse rate of 101, afterwards increase it to 117.

With increasing improvement of fitness the training intensity should be increased to 70% - 85% of your maximum pulse rate.

This can be done by increasing the resistance, a higher frequency or longer training periods.

Training Organization

Warm-up:

Before every your training you should warm-up for 5-10 minutes.

Here you can do some stretching and training with low resistance.

Training session:

During the actual training a rate of 70% -85% of the maximum pulse rate should be chosen.

The time-length of your training session can be calculated with the following rule of thumb:

- daily training session: approx. 10 min. per unit
- 2-3 x per week: approx. 30 min. per unit
- 1-2 x per week: approx. 60 min. per unit

Cool down:

To introduce an effective cool-down of the muscles and the metabolism the intensity should be drastically decreased during the last 5 – 10 minutes.

Stretching is also helpful for the prevention of muscle aches.

Success

Even after a short period of regular exercises you will notice that you constantly have to increase the resistance to reach your optimum pulse rate.

The units will be continuously easier and you will feel a lot fitter during your normal day.

For this achievement you should motivate yourself to exercise regularly.

Choose fixed hours for your training session and do not start training too aggressively.

An old quote amongst sportsmen says:

“The most difficult thing about training is to start it.”

Wish you have a lot of fun and success with your bike,

Parts List**GB**

NO.	Description	Quantity	
1	Main frame	1	
2	Front stabilizer	1	
3	Rear stabilizer	1	
4	Handlebar post	1	
5	Saddle post	1	
6	Saddle adjustable post	1	
7	Saddle	1	
8	Cap (for saddle adjustable post)	2	
9	Fastener (for saddle adjustable post)	2	
10	Knob (for saddle adjustable post)	1	
11	Knob (for handlebar post)	1	
12	Fastener (for saddle post)	1	
13	Saddle post knob	1	
14	Sleeve (for handlebar)	1	
15	Tension control cable	1	
16	Front stabilizer cap	2	
17	Rear stabilizer cap	2	
18	Computer cable (upper)	1	
19	Computer cable (lower)	1	
19	Motor	1	
20	Computer	1	
21	Carriage bolt (for front & rear stabilizer)	4	
22	Domed nut (for front & rear stabilizer)	4	
23	Washer (for front & rear stabilizer)	5	
24	Hex. Bolt (for handlebar post)	4	
25	Washer (for handlebar post)	4	
26	Pedal (R & L)	1	
27	Central chain cover(R & L)	1	
28	Chain cover (R & L)	1	
29	Nut (for idle wheel fixture)	1	
30	Plastic computer holder (R & L)	1	
31	Handlebar	1	
32	Foam grips (pair)	1	
33	End caps (pair)	1	
34	Hand pulse sensor	2	
35	Screw (for chain cover)	5	
36	Screw (for chain cover)	14	
37	Screw driver	1	
38	Allen key wrench	1	
39	Crank arm set	1	
40	Protector (for handlebar post)	1	
41	Screw (for handle pulse sensor)	2	
42	Hand pulse sensor wire	1	
43	Sensor	1	
44	Locknut (for saddle)	3	
45	Washer (for saddle)	3	

46	Protector (for flywheel)	2	
47	Screw (for computer)	4	
48	DC cable	1	
49	Adaptor	1	
50	Screw (for chain cover)	4	
51	Protector (for crank)	2	
52	Screw (for plastic computer holder)	4	
53	Ring (for handlebar post)	1	
54	End cap (for front & middle post)	2	
A1001	Washer (for flywheel)	2	
A1002	Washer (for flywheel)	2	
A1003	Nut (for flywheel)	2	
A1004	Bolt (for idle wheel fixture)	1	
A1005	Bolt (for idle wheel fixture)	1	
A1006	Nut (for idle wheel)	1	
A1007	Steel sleeve	1	
A1008	Screw (for motor)	2	
B2001	Flywheel set	1	
B2002	Belt wheel	1	
B2003	Idle wheel	1	
B2004	Motor	1	
C3001	Ball bearing set	1	
C3002	Spring	1	
D4001	Poly-v belt	1	
D4002	Sensor	1	
D4003	Magnet	1	
D4004	Idle wheel fixture.	1	

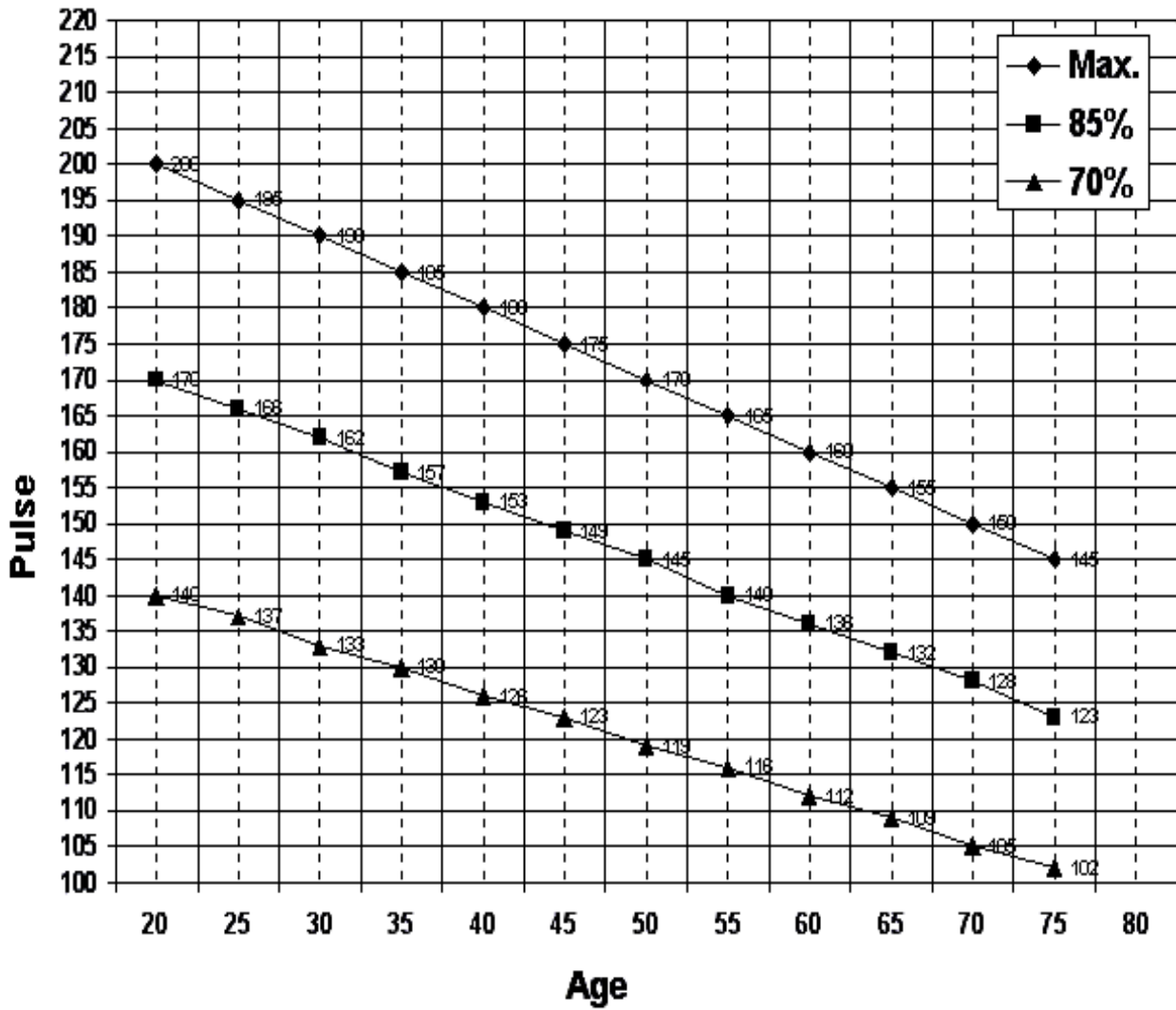

The owner's manual is only for the customer reference.