

# Dawn Trashwheels

## Assembly and Operation Manual

For Models 1130A, 1130C,  
1136A, 1136C, & 1138F  
includes all mounts

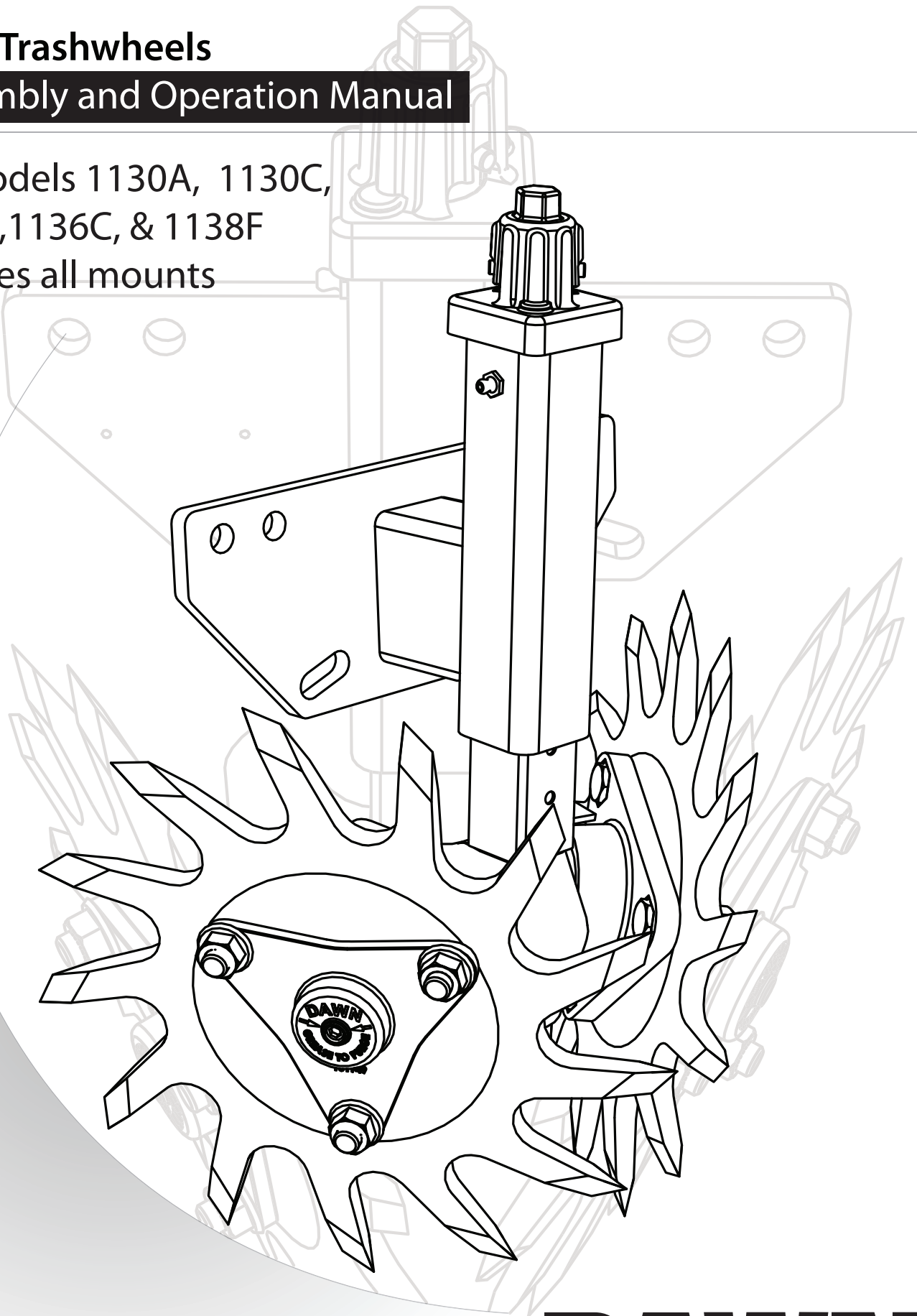

**DAWN**®

# Introduction

## PLEASE CAREFULLY READ THIS MANUAL

It is strongly recommended that you become familiar with all operation and maintenance procedures of your Dawn agricultural equipment.

Failure to follow safety recommendations while this implement is in operation, and/or failure to properly store this implement, and/or failure to adequately prepare this implement for transport, could result in equipment damage, personal injury or death. Please make yourself aware of all federal and local laws that may apply to the transport, use and sale of this implement.

## USING THIS MANUAL

All Dawn manuals are named and numbered and should be considered a principal element of the device they accompany. Please ensure this manual is kept in a location not subject to extreme conditions (i.e. excess humidity, hydraulic fluid, exposed to natural elements, etc.). Please ensure that this manual remains with the implement if traded, leased or sold.

## WARRANTY INFORMATION

All new Dawn Equipment Company products carry a limited warranty. Warranty assurances vary by device, and can be found in the appendices of this or any other Dawn Equipment Company Users Manual. Warranty information is also available upon request by contacting Dawn toll-free at 800.554.0007, or you can request a copy in writing. Request warranty information by e-mail at [info@dawnequipment.com](mailto:info@dawnequipment.com), or by US Post at Dawn Equipment Company, PO Box 497, Sycamore IL 60178.

Dawn Equipment Company prides itself on the manufacture of quality American made row crop tools. Warranties will be honored by Dawn to dealers authorized to sell Dawn Equipment products who, in turn, honor such warranties to the original retail purchaser. Should this equipment be improperly cared for, or should it be modified to change performance beyond OEM specifications, applicable Dawn warranties will become void, and Dawn sponsored implement improvements will not be granted.

## DISCLAIMER

Dawn Equipment Company makes no claim to the safety or reliability of non-Dawn OEM parts or whole goods used in conjunction with Dawn OEM equipment, and shall not be held responsible for any personal injury or property damage, or for any complications with operational performance caused by non-Dawn OEM parts or whole goods used in conjunction with Dawn OEM equipment. Please familiarize yourself with the users manuals and safety recommendations of all non-Dawn OEM equipment.

## WEIGHTS AND MEASURES

All Dawn Equipment Company part and whole good designs adhere to the United States Customary Unit System (Inch-Pound). All measurements in this manual are labeled using only the aforementioned units, unless otherwise explicitly specified.

## ADDITIONAL INFORMATION

Additional information on this, and any other Dawn tool can be found on the web at [www.dawnequipment.com](http://www.dawnequipment.com). You may also contact Dawn for information by phone at 800.554.0007, by fax at 815.899.3663, or by e-mail at [info@dawnequipment.com](mailto:info@dawnequipment.com).



# Table of Contents

---

<b>Safety</b> .....	<b>4</b>
General Safety.....	
Safety Triggers.....	
Reporting an Emergency.....	
Maintenance and Upkeep.....	
Proper Waste Disposal.....	
Safety Gear.....	
Protective Clothing.....	
First Aid Kit and Contents.....	
<b>Trashwheel Introduction</b> .....	<b>6</b>
Mounts.....	
Stems.....	
Orientation.....	
<b>Trashwheel Assembly</b> .....	<b>8</b>
Installation.....	
<b>Appendix A: Warranty</b> .....	<b>10</b>
<b>Appendix B: Quick Reference Assembly Guide</b> .....	<b>11</b>



# Safety Information

---

## GENERAL SAFETY

It is essential that you be able to recognize safety signal words and their associated symbols. Please be alert to any signs posted on your Dawn Equipment Company products, and/or in your users manual. Make sure you have read all safety messages and that you clearly understand the recommended precautions. If you have questions about any Dawn safety sign, or have further questions about safety recommendations on this or any other Dawn product, please contact us at 800.554.0007.

## SAFETY TRIGGERS

Several safety symbols appear with their associated safety words throughout your Dawn Equipment user manual. It is important to recognize and understand these safety signals in order to take appropriate action as necessary.

 **DANGER** - Indicates an imminently hazardous situation that, if not avoided, will result in serious injury or death, and/or property damage.

 **WARNING** - Indicates a potentially hazardous situation that, if not avoided, will result in serious injury or death, and/or property damage.

 **CAUTION** - Indicates a potentially hazardous situation that, if not avoided, may result in minor or moderate injury, and/or property damage.

## REPORTING AN EMERGENCY

Ensure that you have access to a radio or mobile phone when operating or repairing farm machinery. Working with a partner whenever possible significantly increases the chances of receiving timely emergency care should one party become severely injured, and/or incapacitated.

## MAINTENANCE AND UPKEEP

For safety reasons, it is important to keep your implements in proper working order. Unauthorized modifications to Dawn Equipment Company products may compromise the efficiency and/or safe operation of the product and will void any and all warranties through Dawn Equipment Company. Please read your manual before attempting any repair work to your Dawn tool. If you need to work on your Dawn tool, make sure to support it before partially or fully removing it from the attachment points. Do not adjust your Dawn tools while they are moving. Before making adjustments to your Dawn fx tool, make sure to disengage the hydraulic circuit and disconnect the power source.

## PROPER WASTE DISPOSAL

Please familiarize yourself with all waste disposal laws applicable to your area before dumping.



# Safety Gear

## PROTECTIVE CLOTHING

Wearing proper attire when working on agricultural equipment is a critical safety precaution. Loose clothing or accessories may become entangled in moving parts causing serious injury or death. Please ensure that loose cuffs, shirts, belts, jewelry, etc. are secured such that they cannot be drawn into moving machinery. Stay aware of your surroundings when in the proximity of machinery that is either moving or has the potential for spontaneous movement. Equip yourself with all recommended safety accessories, and develop a strategy for ensuring their use when needed.

## Safety Glasses / Goggles

If you will be using hazardous chemicals, or are striking, cutting or grinding metal make sure you are wearing eye protection

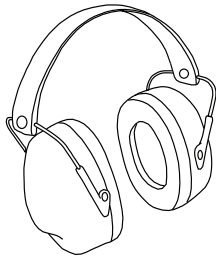
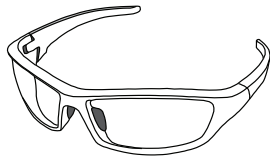

## Earplugs / Sound Mufflers

When working around equipment that generates high amplitude sound (ie dryers, vaccums, etc.), ear protection is strongly recommended.

## Respirator Mask

Please carefully read all safety information associated with any chemicals you will be handling. Use a respirator mask when using hazardous chemicals, (ie Insecticides, HN3, etc.)

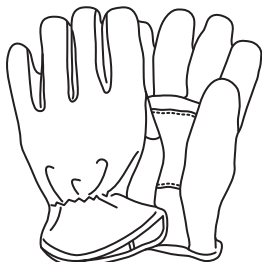
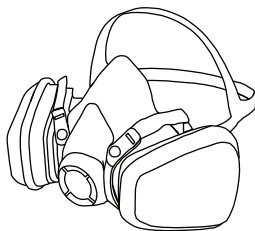

## Work Gloves

If working around machinery with sharp edges, or rough metal surfaces, work gloves may prevent a few stitches. Work gloves are inexpensive, and are really worth the investment.



## Steel-Toed Boots

A good pair of steel-toed boots can save your toes. Avoid an unfortunate accident, and protect your feet

## First Aid Kit

In order to minimize the risk of complication associated with injury, every shop and tractor should have a complete first aid kit.

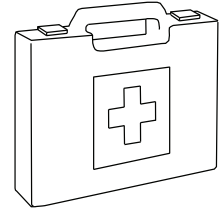

## First Aid Kit Contents

According to the National Agricultural Safety Database (NASD) and Canadian Agricultural Safety Association (CASA), each first aid kit should include the following;

### General Supplies:

- Poison First Aid Kit with syrup of Ipecac and charcoal
- Sterile first aid dressings in sealed envelope ( 2"x2" for small wounds, 4"x4" for larger wounds and for compress to stop bleeding)
- Tongue blades
- Stainless steel bandage scissors (strong enough to cut denim)
- Tweezers
- Eye wash solution
- Thermometer
- Safety pins
- Ace bandage
- "Band-aids"
- Roller bandage 1"x 5 yds. (for finger)
- Roller bandage 2"x 5 yds. to hold dressings in place
- Adhesive tape
- Triangular bandages for a sling or as a covering over a larger dressing
- Cotton balls for cleaning wounds or applying medication
- Splints 1/4" thick, 1/2" wide, 12-15" long for splinting broken arms and legs
- 70% isopropyl alcohol and tincture green soap in a covered container for cleaning
- Ice packs (chemical ice bags) to use to reduce swelling
- Several pairs of disposable latex or nitrile gloves
- Waterless hand wash
- emergency tourniquet (or elastic wrap/tubing)
- Cold pack
- Amputation preservation kit consisting of plastic bags: one large garbage bag, four kitchen-sized and two bread bags.



# Introduction

## PLANTER COMPATIBILITY

To ensure fit, double check your planter and row-unit models before attempting to install your Dawn tools. There are multiple models designed for specific planters/row units which are NOT interchangeable.

### John Deere & Bauer Built Manufacturing

Models 7000 & 7100  
require the 1140-5 mount

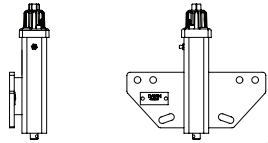

Models 7200 & 7300  
require the 1140-1 mount

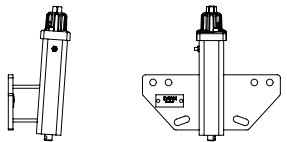

**⚠ CAUTION** If you have a 7200 Conservation Tillage planter from the early 90s, you will need to check the lower parallel link weldment.

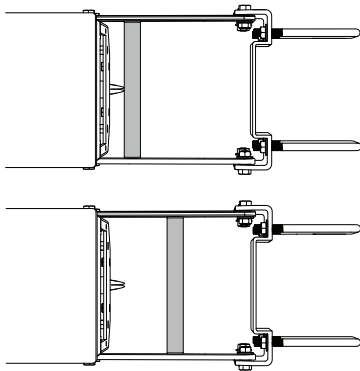

If the cross member is placed near the row unit, no Dawn fixed row cleaners will fit.

If the cross member is placed in the middle, a standard 1140-1 mount may be used.

For 7200 series "conservation tillage" planters

All 1700 series Deere and  
all Bauer planters require  
the 1140-2 mount

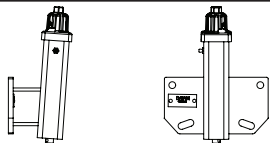

### FOR ALL Deere/Bauer MODELS

With long parallel links  
use 1140-2sp6.25

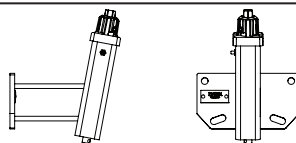

With "heavy-duty" scrapers  
use 1140-2sp3.25

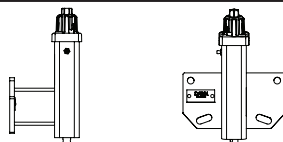

## Case

Models 1240 & 1250  
require 1140K-3 mount

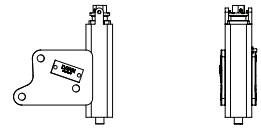

Models 800, 900 & 955  
require 1140-3 mount

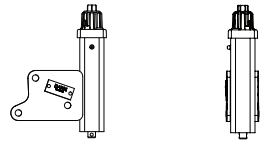

## Kinze

All 3000 series with  
air bags require the  
1140k-1 mount

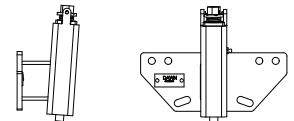

All 2000 series after 1993,  
and 3000 series with spring  
down-pressure require  
1140-1 mount

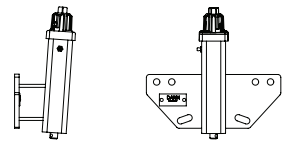

Models manufactured  
prior to 1993 require  
the 1140-5 mount

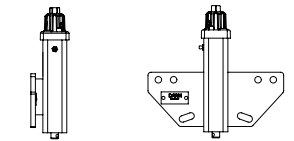

## White

All 6000 and early  
8000 series require  
the 1140W-1 mount

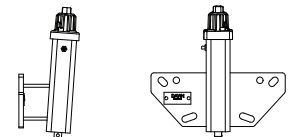

8000 series planters  
with air bags require  
the 1140W-5 mount

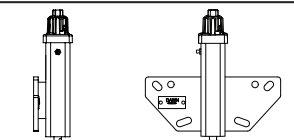

**NOTE** For White planters with air bags, you will need to reverse the lower parallel links so the cross member does not interfere with the Trashwheel assembly.





# Introduction

## TRASHWHEEL STEMS

Each Dawn Trashwheel stem is available in either a 4 hole version for 12.75" Trashwheels, or 6 hole version for either staggering or intersecting 14" Trashwheels. It is not possible to run 12.75" or 15" wheels in the intersecting position. Your stem must match the Trashwheels you plan on running.

**1130** - Most common Trashwheel stem for clearing full-width path of the gauge wheels. Perfect for 22"-30" rows. Available as 1130A for Deere, Kinze and White. Also available as 1130C for Case. Not recommended for 15" rows.

**1136** - Single wheel for narrow rows where two Trashwheels will not fit. Works well on 15" rows. Available as 1136A for Deere, Kinze, and White. Also available as 1136C for Case.

**1138** - Dual Trashwheel setup for aggressive cleaning on narrow rows. Do NOT use in worked ground. 15"-20" rows. This is a specialty tool, please contact a Dawn representative to discuss your application. Also consider the 2003 narrow-row coulters combination as an alternative.

## TRASHWHEELS

There are three different Trashwheel options by size. Be sure to check planter specifications before ordering because not all wheels will fit on every planter. Each Trashwheel is identified by its diameter.

**12.75"** - The most common wheel is the 12.75" Trashwheel. The 12.75" wheel is widely used in mixed tillage applications and in fields that are conventionally tilled or minimum tilled. This wheel is also commonly used on the Dawn 1572 no-till coulters combination.

**14"** - The 14" is the next size up and with its radially straight tines, has the unique ability to be set in the "intersecting" position. This allows for aggressive row-cleaning with relatively narrow spacing. This is only recommended for exclusively no-tilled ground. Do NOT run wheels in intersecting position in worked ground.

**15"** - The largest wheel offered by Dawn uses an integrated hub that is designed to reduce wrapping in extreme residue conditions. This wheel will not fit on most planters and is reserved for special applications and devices designed with this wheel size in mind.

## ORIENTATION

All Trashwheels are directional! For the 12.75" wheel and the 14" wheel, you may disassemble the hub to change the Trashwheel orientation or for Trashwheel replacement. Due to the integrated hub on the 15" Trashwheel, you will need to order dedicated right-hand or left-hand wheels.

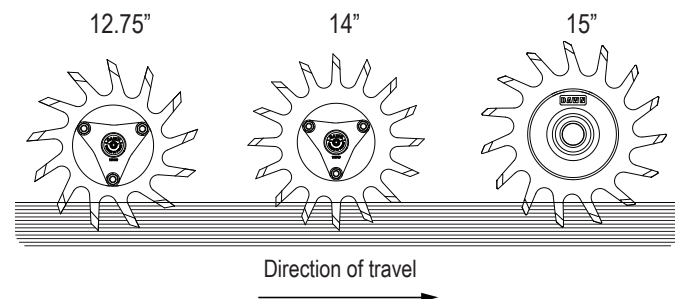

## OFFSET VS. INTERSECTING

Row cleaners should only be put in the intersecting position if there is a specific reason to do so. Generally, it is not necessary to run your Dawn Trashwheels in the intersecting position. Running the Trashwheels in the intersecting position in the conventional tillage conditions may result in plugging problems. Please contact your Dawn dealer or Dawn Equipment Company for details. For most applications, an offset configuration is preferred.

**NOTE** The only Dawn Trashwheels that can be set in the intersecting position are the 14 inch wheels with straight teeth. 12.75 inch and 15 inch wheels **must** be set in the offset position.

## HANDEDNESS

In order to draw residue outward from the center of your planter, you will want to setup half of your Trashwheels in the left handed configuration and half of your Trashwheels in the right handed configuration.

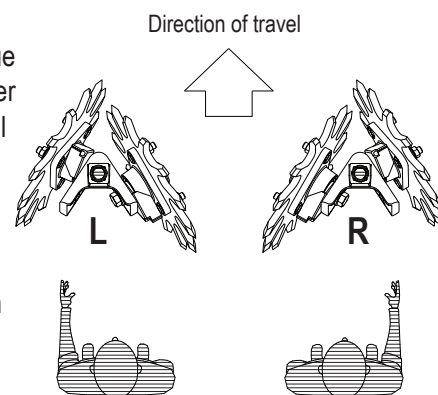

## DEPTH BANDS

Depth bands give flotation and reduce the aggressiveness of your Trashwheels. For most growers there is no need for depth bands on fixed Trashwheels.



# INSTALLATION

## TRASHWHEEL ASSEMBLY

For this assembly you will need;

- One (1) 3/4 SAE socket
- One (1) 3/16 Allen wrench
- One (1) 15/16 SAE open ended wrench
- One (1) Bench vise

**NOTE** For some shipments, Trashwheel, hub, and depth band assembly are taken care of in house by Dawn. If your Trashwheels have been shipped already assembled, feel free to skip this step.

**1** Lightly grease O-ring (P/N 9662) with Mobile XP222 or similar and place into groove on the underside of the aluminum Supercap. Do not install pipe plug until the end.

**2** To assemble Trashwheel, insert 1/2"-13x1.75" HHCS (P/N 9088) through hub flange, Trashwheel, Supercap, and loosely thread on nut (P/N 9007-R1). Repeat for the other two bolts.

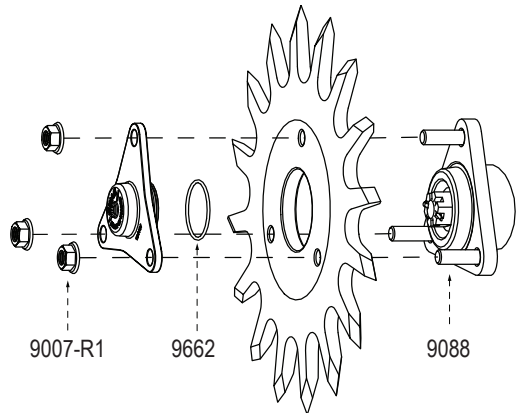

**NOTE** Trashwheels are directional! They can be assembled as either RIGHT handed or LEFT handed wheels. Assemble and install wheels according to rotational arrows on each wheel indicating the direction of travel. Trashwheel teeth appear "swept back".

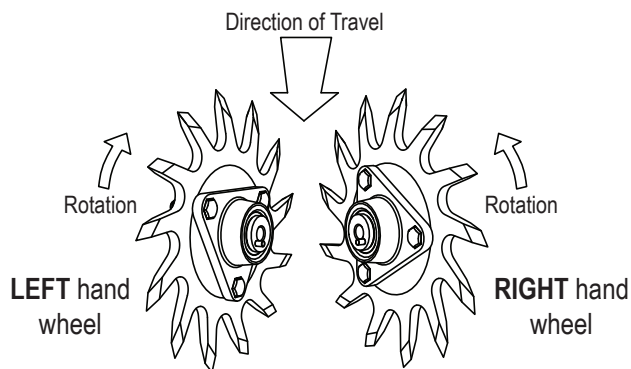

**3** Once Trashwheel assembly is complete, tighten all nuts, install grease zerk and fill hub with grease until clean grease comes out the far side. Once hubs are greased, install pipe plugs.

**4** Clamp Trashwheel stem into a bench vise by its square tube with the "V" pointing down for easy wrench access. Insert 5/8"-11x1.5" HHCS (P/N 9101) through washer, stem, stripper and into hub.

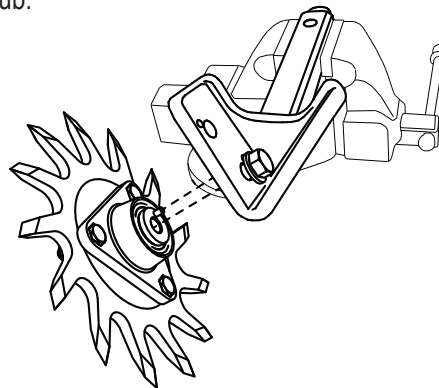

**NOTE** When installing hub strippers for the forward hole, align the stripper and roll pin so that the stripper points up. For the rear position, align the stripper and roll pin so that the stripper points away from the motion of travel.

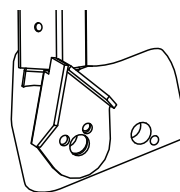

Forward Hole

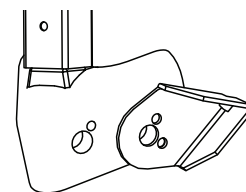

Rear Hole

## INSTALLING THE MOUNT ASSEMBLY

For this assembly you will need;

- Two (2) 3/4 SAE sockets or box wrenches

**4** For Deere, Kinze and White units, bolt the Trashwheel mount to the row unit by inserting 1/2"-13x1.25 HHCS through washer, mount plate, row unit and loosely thread into self-locking nut. Repeat for remaining three bolts. Tighten all four bolt heads.

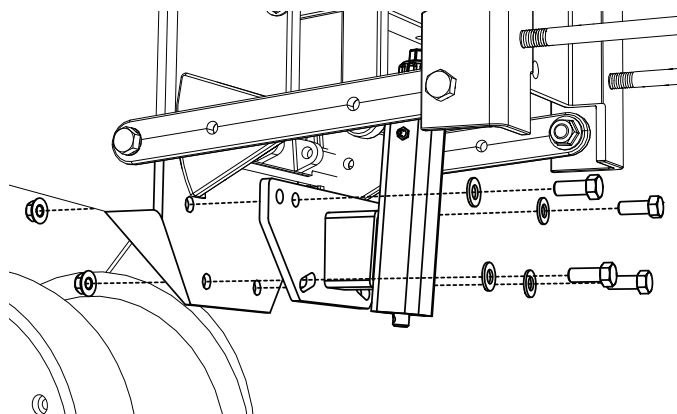



---

## INSTALLING THE TRASHWHEEL ASSEMBLY

Thread the acme screw in the Trashwheel mount assembly into the Trashwheel stem by lifting and turning the Dawn screw-adjust cap and turning the cap. Continue turning until only one and a half dots are visible on the front of the stem.

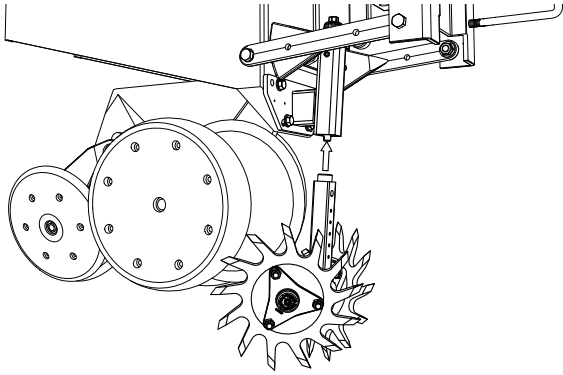

## OPERATION

To operate your Dawn screw-adjust caps,

- A) Lift cap free from magnet
- B) Turn to adjust depth of Trashwheel
- C) Square cap with tube and re-engage magnets

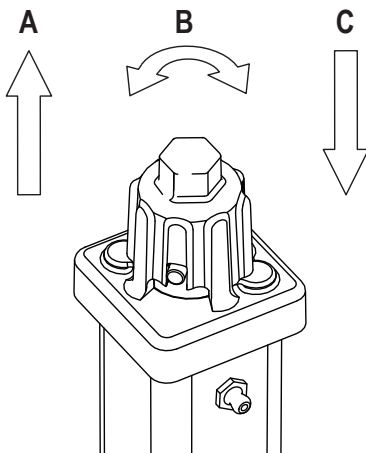

**NOTE** Due to the "T" slot on the screw-adjust cap, you may have to turn slightly past your intended stop to engage magnets.



# Appendix A - Warranty

The following warranties with respect to new Dawn Equipment Company ("Dawn") products, excepting as hereafter provided, is made by Dawn to Dealers ("Dealers") authorized by Dawn to sell the products involved and each selling Dealer, in turn, make such warranties to the original retail purchaser (the "Purchaser").

## A. Duration and Extent of Warranty

1. Products, except all working, moving and all or any parts subject to wear, except as hereafter provided, which are defective in materials or workmanship as delivered to the Purchaser by a Dealer will be repaired by a Dealer or replaced by Dawn, only, as Dawn elects, without charge for materials or labor, if such defect appears in not more than 12 months, or from and after the date of delivery to the Purchase by the Dealer.
2. Dawn warrants that the Trashwheels planter attachment wheels (Dawn part #s 200015, 101550, 102185M-L, 102185M-R, 102540F) will not bend or break during its useful lifetime.
3. Liability of Dawn for defective parts or material is specifically limited to the value of the parts or materials, only.
4. All parts or materials requiring warranty work MUST be returned by delivery to the selling Dealer for repair or for delivery to Dawn within thirty (30) days of occurrence of the defect or failure of the part or material, all freight prepaid by the Dealer. Dealer must complete Dawn warranty request form before shipping to Dawn. Upon completion of the warranty work, Dawn will ship parts or material to the Dealer, freight prepaid by Dawn.
5. All decisions by Dawn pertaining to warranty are final.

## B. Warranty Exclusions; Dawn will not be responsible for any of the following:

1. Defects or damage resulting from use, repairs or service performed in a manner not approved by Dawn or from repairs or service performed by someone other than an authorized Dawn Dealer service department (after approval from Dawn) or Dawn to repair or replace the product involved.
2. Defects, damage or failure resulting from any alteration or additions done in a manner not approved by Dawn.

3. Defects, damage or failure or depreciation resulting from wear and tear, accident, misuses, negligence, improper maintenance or improper protection and storage.
4. INCIDENTAL OR CONSEQUENTIAL DAMAGES, INCLUDING BUT NOT LIMITED TO, LOSS OF PROFITS, LOSS OF TIME, LOSS OF CROPS, INCONVENIENCE, LOSS OF USE OF THE PRODUCT OR OTHER MACHINERY, EQUIPMENT OR VEHICLE USED WITH THE PRODUCTS, COST OF RENTALS OR REPLACEMENT OF THE PRODUCTS OR OTHER COMMERCIAL LOSS.

## C. Remedies Exclusive: NO Other Warranties

The obligations of Dawn and the Dealers are limited to the obligations set forth in this Limited Warranty. THIS LIMITED WARRANTY IS IN LIEU OF ALL OTHER WARRANTIES OF DAWN, AND THE DEALERS, EXPRESSED OR IMPLIED. WARRANTIES BY DAWN OR THE DEALER OF CONDITION QUALITY, MERCHANT ABILITY OR FITNESS FOR A PARTICULAR PURPOSE ARE EXCLUDED, AS ARE ALL OTHER REPRESENTATIONS BY DAWN AND THE DEALERS TO THE PURCHASE OR USER AND ALL OTHER OBLIGATIONS OR LIABILITIES OF DAWN AND THE DEALERS. NO OTHER PERSON IS AUTHORIZED TO GIVE ANY OTHER WARRANTY OR TO ASSUME ANY OTHER LIABILITY ON BEHALF OF DAWN OR THE DEALERS. THIS LIMITED WARRANTY MAY NOT BE TRANSFERRED BY THE PURCHASER TO ANY SUBSEQUENT OWNER.

D. The instruction manual supplied with the Product contains important maintenance and service information. Read the manual and follow the recommendations contained herein. Please remember that failures due to improper maintenance or service are not covered by the Limited Warranty.

Dawn Equipment Company reserves the right to make changes in design or specifications at any time without obligation to purchasers or equipment and components previously sold. This warranty shall not be altered or changed in any way.

# Appendix B - Quick Reference Guide

1.

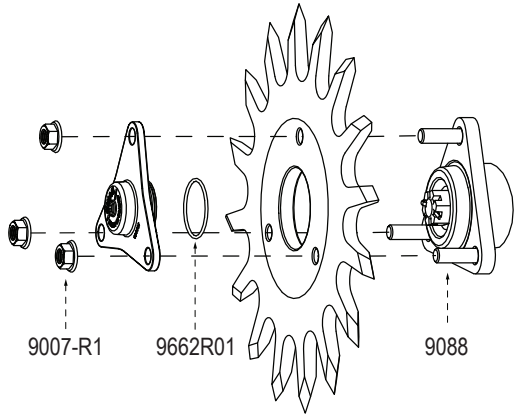

4.

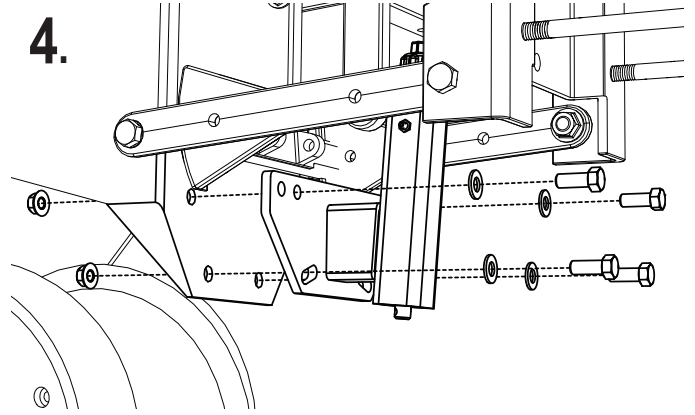

2.

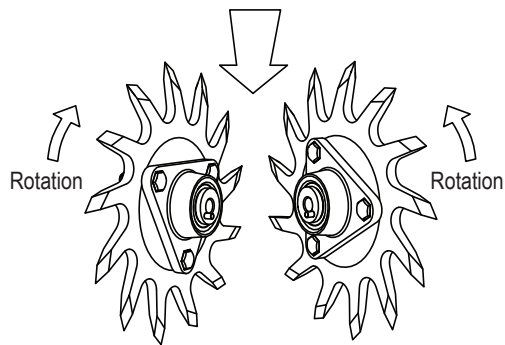

5.

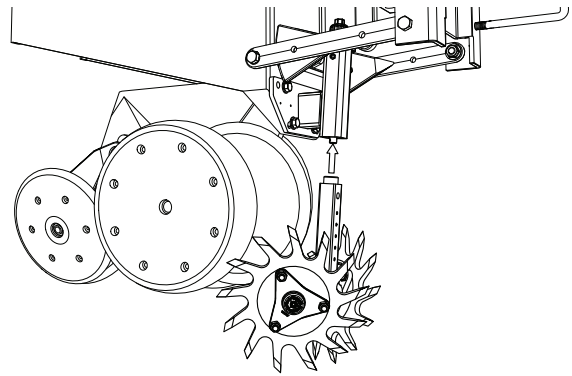

3.

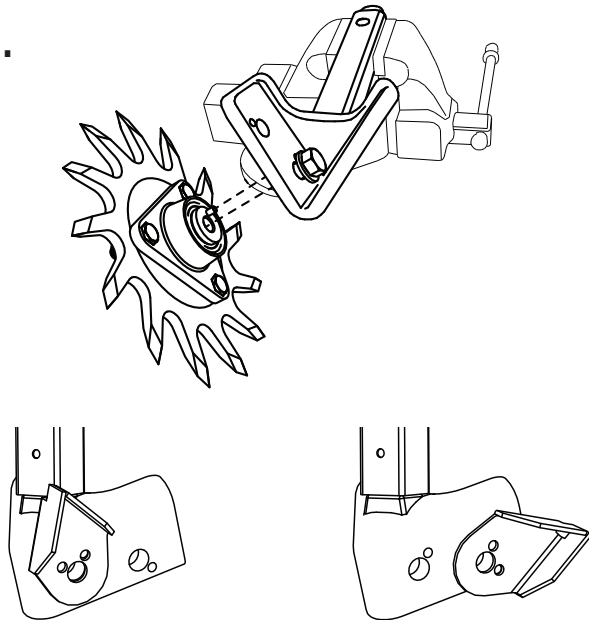

6.

