

CP-AW3019WNM

ULTIMATE 究極
INTERACTIVE



ULTIMATE INTERACTIVE WXGA LCD PROJECTOR

The Ultimate Short Throw series provides high performance projection in small spaces. By integrating Hitachi StarBoard™ software with advanced projector technology, the CP-AW3019WNM can deliver the complete interactive experience on any flat surface. The compact, lightweight chassis and optional wireless capability makes this projector easy to install and flexible to use. With the bundled wall-mount and optional tabletop kit you can project onto any existing whiteboard, wall or tabletop.

Interactive

- Pen-based single touch interactive system with Hitachi StarBoard™ software
- Rapid, precise response to user input
- WXGA resolution (1280 x 800)
- 80" (2m) image from only 56cm*
- 3000 ANSI lumens (Normal Mode)
- 4000:1 contrast ratio
- Full connectivity including HDMI
- Perfect Fit – adjust all four corners and sides of the image individually to achieve a distortion free image
- Tabletop mount facility
- 16W speaker
- Anti theft features

Cost of ownership

- Extended Hybrid Filter life – up to 4000 hour cleaning cycle
- Extended lamp life – up to 4000 hours in Eco Mode
- Virtually maintenance free
- Easy setup and installation
- Wall mount included in the box

Advanced Network Features

- Full connectivity including wireless (optional) and ethernet
- Configure and control projector via network with a web browser
- Projector management via SNMP
- Wireless network (option)
- Content via LAN
- AMX Device Discovery
- Crestron Roomview™
- Messenger
- PJ Link™
- Network Bridge

Environment

- The extended Hybrid Filter life means reduced electronic waste and reduced maintenance visits, resulting in an overall reduction in carbon footprint

Hitachi have formulated an "Environmental Vision" to contribute towards building a sustainable society through business and product development.

Our goal is to develop life-enhancing technology that will contribute to and realise a truly sustainable society for current and future generations.

StarBoard™ software requirements

- CPU: Intel Pentium 4 1.8GHz or faster • Hard disk: minimum 600MB
- RAM: minimum 1GB • Display colours: minimum 32bit
- Operating system (OS): Windows XP 32bit/Windows Vista 32bit/Windows 7 32/64bit (the latest service pack must be applied) (Tablet PC Edition and Server Edition are not supported)
- Software required: Internet Explorer 6.0/7.0/8.0 (for viewing Online Help and using Internet search functions) PowerPoint 2002/2003/2007/2010 (for viewing PowerPoint documents), Adobe Flash Player 10 (for using Flash object)
- Others: DVD drive, video card with hardware overlay feature (for using movie features)

*From centre of mirror to screen



CP-AW3019WNM Technical Specifications

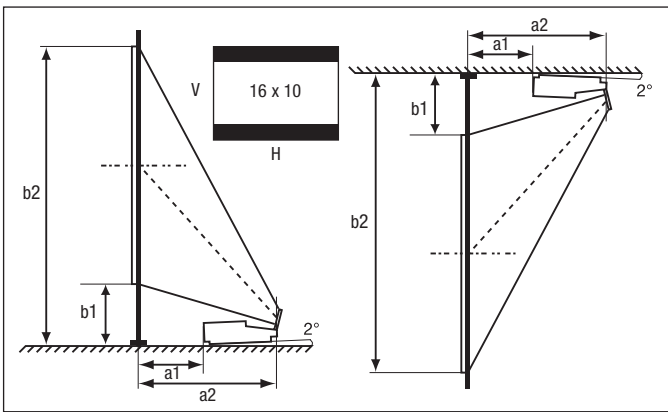
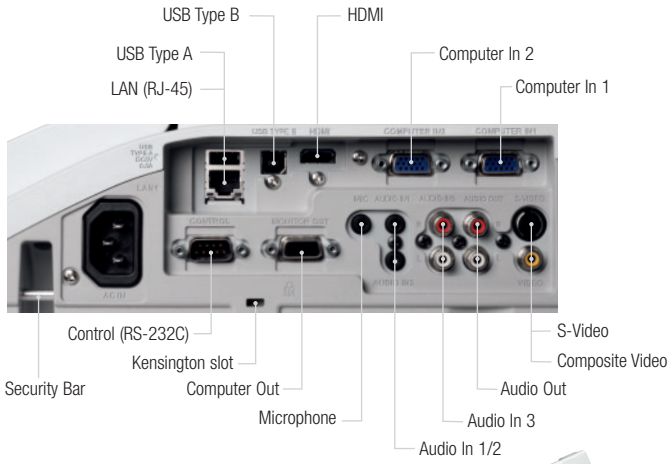

Throw distance (from the top of the lens)

Screen size (diagonal)	H x V		a1	a2	b1	b2
	(m)	(m)				
60" (1.5m)	1.3	0.8	0.120	0.426	0.295	1.102
70" (1.8m)	1.5	0.9	0.188	0.494	0.332	1.274
80" (2.0m)	1.7	1.1	0.256	0.562	0.369	1.446
90" (2.3m)	1.9	1.2	0.324	0.631	0.407	1.618
100" (2.5m)	2.2	1.3	0.392	0.699	0.444	1.791

StarBoard™ software special requirements

For Webcam playback and capturing feature

- DV (Digital video, DV cameras, D-VHS)
- Capture devices which support DirectShow (with WDM drivers)

For Conference host feature

- CPU: Intel Core 2 Duo 2.0GHz or faster
- Free hard drive space: 2GB or more
- RAM: 2GB or more
- Others: TCP/IP 54Mbps or above

OPTICAL

Interactive sensor (IR and ultrasonic waves system)	Single touch, an interactive pen is required
LCD Panel	0.59" (1.5cm) P-Si TFT x3
Resolution	WXGA (1280 x 800)
Brightness	Normal Mode
	Eco Mode
Colour light output	3000 ANSI Lumens
Contrast Ratio	2000 ANSI Lumens
Lens	3000 ANSI Lumens
Lamp Wattage	4000:1
Lamp Life	Free shaped lens and motorised free shaped mirror
Distance to Width Ratio (:1)	250W
Diagonal Display Size	2500 Hours (Normal Mode)/4000 Hours (Eco Mode)*
Number of Colour	0.3:1 (fixed)
Keystone	60~100" (152~254cm)
	8 Bit/colour, 16.7M colours
	Fixed, 5.2:-1 upward shift

COMPATIBILITY

Computer Compatibility	IBM Compatible VGA, SVGA, XGA, WXGA, WXGA+, SXGA, WSXGA+, UXGA, MAC 16"
Video Compatibility	NTSC/PAL/SECAM/PAL-M/PAL-N/NTSC4.43 SDTV: 525i(480i), 525p(480p), 625i(576i) HDTV: 750p (720p@50/60Hz), 1125i(1080i@50/60Hz), 1125p(1080p@50/60Hz) DDC2B
Plug & Play	

FEATURES

Speakers	16W Mono
Basic functions	Digital zoom x1.35, Freeze, Magnifying, Blank, Auto adjustment, Search
Picture adjustments	Equalizing Gamma Correction, 2-3 pull down, Progressive Scan, Noise Reduction, Perfect Fit
Digital keystone	Manual V Keystone correction, Manual H Keystone correction
Advanced features	Drawing function (optional wireless tablet required), MyScreen, My Memory, My Button by remote control, Blackboard/Whiteboard mode, Daytime Mode, Input source naming (English), Resolution setting, Template, Saving mode, AudioPass through, My Text, ImageCare™, Cloning function
Easy Lamp replace	replace from Top, Rear intake air filter
Outward Power on & off	Direct on, Auto off
Security systems	PIN Security Lock, MyScreen Password Lock, Transition Detector, My Text Password Lock, Key Lock (key pad, remote control), Kensington slot, Security bar, Lens door lock
Network	Configure and control projector via web browser, receive alerts via e-mail, projector management via SNMP, Scheduling, My Image, displaying text data transferred via the network, Command Control via network, Crestron RoomView™, AMX Device Discovery, PJ Link™, Network Bridge, MAC address displayed on the side
OSD Languages	English, French, German, Spanish, Italian, Norwegian, Dutch, Korean, Japanese, Portuguese, Simplified Chinese, Traditional Chinese, Swedish, Russian, Finnish, Polish, Turkish, Arabic, Persian, Czech, Danish, Hungarian, Romanian, Slovenian, Croatian, Greek, Lithuanian, Estonian, Latvian, Thai, Portuguese (Brazil), Indonesian, Vietnamese

CONNECTIONS

Digital Input	1 x HDMI
Computer Input	2 x 15-pin Mini D-sub
Computer Output	1 x 15-pin Mini D-sub
Video Input	1 x RCA Jack (for composite)
	1 x S-Video Jack
	2 x Component D-sub (shared with analogue RGB)
Audio Input	2 x Stereo Mini Jack
	1 x pair RCA (L/R)
Audio Output	1 x Microphone Jack
Control	1 x pair RCA (L/R)
USB	1 x 9-pin D-sub for RS232 control
	2 x USB type A for PC-less presentation and optional wireless pen tablet
	1 x USB type B for remote control mouse or PC screen display (selectable with User Menu) used for interactive function
Wired network	1 x RJ-45
Wireless network	Yes (option)

POWER

Power Supply	AC100-120V/220-240V, auto switching
Power Consumption	360W (AC 220-240V)
Power Consumption in Standby	<0.35W

PHYSICAL

Dimensions (W x H x D)	345 x 102 x 303mm (excluding feet and extrusions when mirror is closed)
Weight	4.1Kg
Noise Level	38dB (Normal Mode)/31dB (Eco Mode)
Air Filter	Hybrid (up to 4000 hours)

MISCELLANEOUS

Lamp indicator light, Power light, Ceiling mount image, Rear projection image, Serial number label on side

CERTIFICATION

UL60950-1/C-UL, FCC Part 15 subpart B class B, CE Marking: EN61000-3-2, EN61000-3-3, EN55022 (class B), EN55024 (EMC directive), EN60950-1 (low voltage directive), WEEE/RoHS/ErP (lot 6) compliant, c-tick class B, GOST-R

ACCESSORIES SUPPLIED

Remote control with batteries (HL02882), RGB cable, power cord, cable cover, security label, user manual (detail & concise), wall mount (HAS-K250), interactive pen with batteries, USB cable (5m), StarBoard™ software and manual, Application DVD (StarBoard™ software)

OPTIONAL ACCESSORIES

Replacement lamp	DT01411
Filter set	UX37191
Table top stand	TT-251
USB wireless adapter	USB-WLAN-11N
Solution product	TB-1 Wireless interactive tablet

WARRANTY

Projector warranty	3 Years
Lamp warranty	Please consult your local Hitachi agent for the latest offer



Wedgwood AV Ltd
Audio visual supplier since 1996

Wedgwood AV Ltd

Specialise in the supply of audio visual equipment to UK medical, MOD, education and businesses

Tel: 01754 769967 / 0800 018 9967

FREE Repeat Signage Standalone digital signage software for Windows with every order over £500+VAT purchased from Wedgwood AV Ltd in 2015

Full product list FREE AV guides



LCD monitors

Wedgwood are giving away Repeat Signage Standalone Edition worth £145+VAT with any products with a total order value of over £500+VAT purchased during 2015 from Wedgwood AV Ltd. sales@wedgwood-group.com (Order value £1,000 +VAT will receive two software licences; £1,500+VAT three licences).

Repeat Signage helps you get your message across, to promote your products or services. You can display still and moving images, scrolling text messages, RSS feeds (such as the BBC weather or your local news), show webcam or web browser, add audio, PowerPoint scheduler, Flash clocks, and even display pictures which text. [See 2 minute video](#). [Trial download](#)

Contact us - how to order

For a quotation or to place your official purchase order and receive your FREE Repeat Signage digital signage software please telephone 01754 769967 or fax 01754 768036 Email sales@wedgwood-group.com [Special offers](#)

Wedgwood AV Ltd - 01754 769967 www.wedgwood-group.com



Mount solutions



Touch screens



Digital signage



Medical monitors



Lecterns



Audio



Whiteboards



Projectors



Projector lamps



Projector lenses



Projector screens