



EPIMAX™ AUTOMATED PUMP USER MANUAL

Rev 2.0

CAT#: ASP-D100NA, ASP-D100EA

Published August 1, 2007

EPITOMICS EPIMAX™ AUTOMATED PUMP USER MANUAL

1.0 TABLE OF CONTENTS

2.0 Introduction	p.2
3.0 Pump Features	p.2
4.0 Packing List	p.3
5.0 Technical Specification	p.4
6.0 Pump Installation	p.5
7.0 Pump Operation	
7.1 Charging the Battery	p.5
7.2 Power On and System Self Check	p.6
7.3 Syringe Installation	p.8
7.4 Setting Flow Rate	p.6
7.5 Setting/Displaying Syringe/Reagent Volume	p.6
7.6 Displaying Total Volume	p.6
7.7 Setting System Pressure Level	p.6
7.8 Automated Control Setup	p.7
8.0 Maintenance	p.8
9.0 Alarm Reference and Troubleshooting Guide	p.9
10.0 Related Products	p.9
12.0 Contact Info	p.9
13.0 Disclaimer/Warranty	p.10

2.0 INTRODUCTION

EpiMAX™ Automated Pump is a digital fixed-volume pump, featuring high precision control and timing for consistent and wide allowance range of flow rates ideal in protein chromatography and related applications. EpiMAX™ Automated Pump is compatible with 3 syringe volume settings (20ml, 30ml, and 50ml) and it is optimized to be used with EpiMAX™ Affinity Purification Kit (Cat# 6000-1) for a complete automated antibody purification system.

3.0 PUMP FEATURES

EpiMAX™ Automated Pump features micro propulsion system for precise pump volume and consistent flow rate. EpiMAX™ Automated Pump is a fixed-volume pump and unlike constant-pressure pump (e.g. creeping pump), the flow rate and set volume is not affected by column pressure. When the maximum pressure set level reached, EpiMAX™ Automated Pump will automatically stop and notify the user to release the column pressure preventing alteration of column flow rate and set volume.

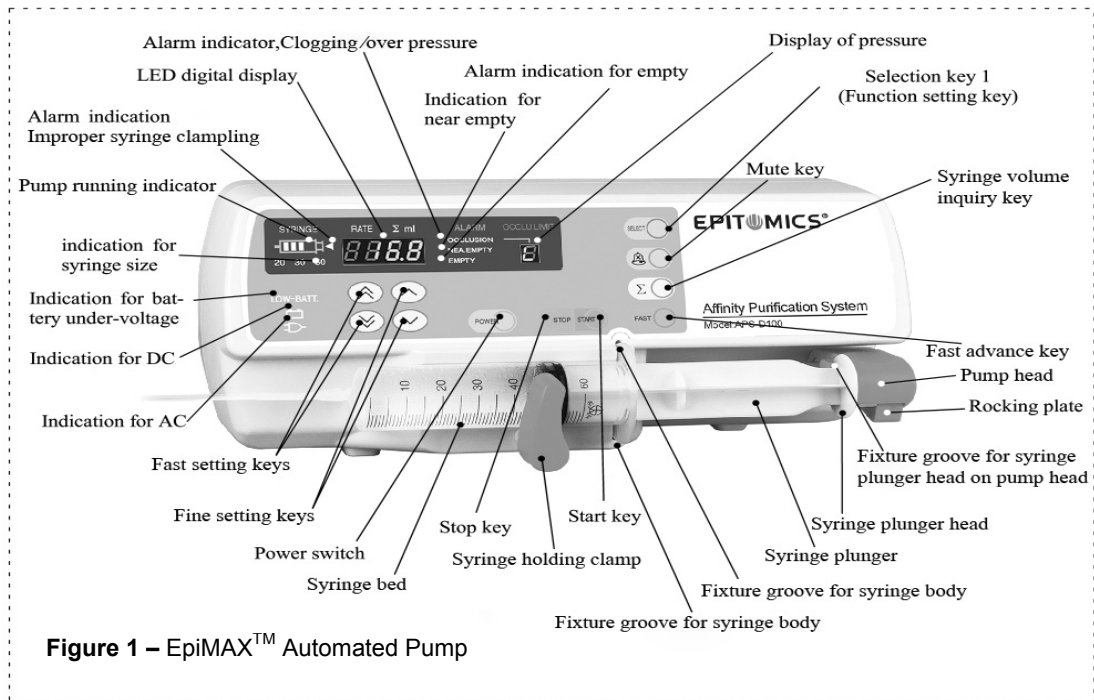

Setting up in EpiMAX™ Automated Pump is fast and simple with Auto Syringe Detection. When a syringe with specified volume (20, 30, or 50 ml) is attached to the syringe bed, EpiMAX™ Automated Pump will automatically detect the syringe volume and adjust the flow rate and volume range to optimal level. Enter desired output volume and flow rate, EpiMAX™ Automated Pump will start to deliver desired volume at preset constant flow rate.

As a preventative feature, the following alarm settings are built in to EpiMAX™ Automated Pump to maintain optimal performance:

- When remaining buffer in the syringe is less than 1.5ml, the **Near Empty Alarm Indicator** alarm will be activated.
- After the last 1.5ml buffer is delivered, **Empty Volume** will be activated and the pump will automatically stop.
- When pump pressure builds up as a result of column clogging/tubing closure, **Clogging/over-pressure** alarm will be activated and the pump will automatically release the pressure and stop.
- During loss of power (e.g. low or dead battery, lost of power source), either Low Battery Voltage Alarm or Power Alarm will activate, automatically saving previous settings (e.g. flow rate, volume level), and shuts down.

4.0 PACKAGE CONTENTS

The following components are included in the box:

- Automated Pump
- Power Cord
- Clamp Hold Set (Clamper Holder, Screws, Mini Wrench)
- Pump Document (User Manual, Quick Guide, Quality Certification)

5.0 TECHNICAL SPECIFICATIONS

Description	Specification	Notes
Syringe Adaptability	Standard 20, 30, 50 ml Syringes	
Volume Limit	0-9999 ml	Below 1000ml - 0.1 ml increments, Above 1000ml - 1ml increments
Accuracy	≤±2%	Drive accuracy: ±1%
Clogging/Over-Pressure	Low Pressure (L): 40N ± 10N High Pressure (H): 60N ± 10N	
Alarms	<ul style="list-style-type: none"> • Near Empty Volume (NEA.EMPTY) • Empty Volume • Improper syringe clamping, • Wrong clamping of syringe plunger • Malfunction or missing operation after initiation • Clogging/over pressure • Output volume equal to preset volume • Low battery • Power failure. 	
Power	AC230V, 50/60HZ (For Europe & Asia, ASP-D100NEA); AC110V,50/60(For North America, ASP-D100NA), DC12V	The pump can run continuously for over 4 hours at the rate of 5ml/h with internal battery after 16 hours of charging
Operation Condition	Temperature: +5 to +40°C ; RH: 20% to 90%	
Transportation and Storage	-40 to +55°C ; RH: ≤95%	
Dimensions	307(L)×135(D)×128(H)mm	

Pump Rate

Syringe Volume	20ml	30ml	50ml
Flow Rate	0.1-399.9ml/h	0.1-399.9ml/h	0.1-399.9ml/h
Rapid Rate	399ml/h	600.0ml/h	1200.0ml/h

6.0 PUMP INSTALLATION

EpiMAX™ Automated Pump can be installed horizontally or vertically to a supporting pole by using the clamp located on the back of the pump (Figure 2).

Figure 2 – Clamp Setup for EpiMAX™ Automated Pump

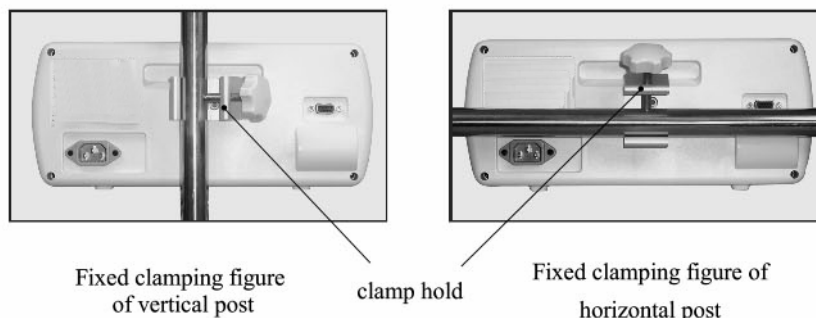

7.0 PUMP OPERATION (Please read through entire procedure before beginning)

7.1 Charging the Battery

- Connect the pump to an AC power source. The AC power indicator will light and pump will go into charge mode. Before the first use allow the battery to charge at least 16 hours.

7.2 Power On and System Self Check

- Press and hold **Power Key** for 2 seconds to turn on the pump.
- Pump will enter **Self-Check Mode**. Check LED display for any error messages.
- If there is no error message displayed, the pump is functional and ready to be used. If there is any error message, please refer to the Alarm Reference/Troubleshooting Section (Section 9) for appropriate action.

7.3 Syringe Installation

- Pull the syringe plunger and allow appropriate amount of liquid reagent to enter the syringe.
- Remove air bubbles in the syringe by dislodging the bubbles with gentle tapping and pushing the excess air with syringe plunger.
- Turn the **Syringe Holding Clamp** counterclockwise direction to expose the **Syringe Bed**.
- While pushing the Rocking Plate on the **Pump Head**, push the **Pump Head** all the way to the right.
- Insert the reagent loaded syringe into the **Syringe Bed** and secure it into the **Fixture Groove** for **Syringe Body** and **Syringe Plunger Head** (Figure 3).
- Place the **Pump Head** on top of **Syringe Plunger Head**.
- Turn the **Syringe Holding Clamp** clockwise direction to lock the syringe in place.
- Press **FAST Key** once.
- Press and hold **FAST Key** again until reagent is coming out of the syringe tip.
- Connect the prepared column to the syringe.

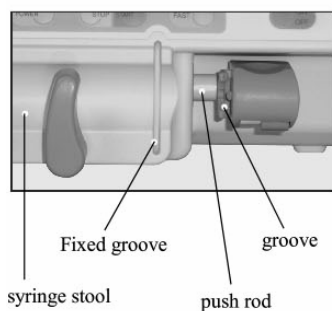

Figure 3 – Fixed groove for Syringe Body and Plunger

7.4 Setting Flow Rate

- a. Press **STOP key** to enter **STOP Mode** (Flow rate can be only set during **STOP mode**)
- b. Press **Selection Key** until you enter **Flow Rate Setting Mode** (ml/h sign will light up).
- c. Current flow rate will be displayed on the LED Digital display.
- d. Using either **Fast Setting Keys** or **Fine Setting Keys** adjust the flow rate until desired flow rate is reached.
- d. Press **Selection Key** to go next setting or press **START** to initiate the pump.

7.5 Setting/Display Volume

7.5.1 Setting Reagent Volume in the Syringe

- a. Press **STOP key** to enter **STOP Mode**.
- b. Press **Selection Key** until you enter **Volume Setting Mode** (Σ ml sign will light up).
- c. Current reagent volume will be displayed on the LED Digital display.
- d. Using either **Fast Setting Keys** or **Fine Setting Keys** adjust the volume until desired volume is reached.
- e. Press **Selection Key** to go next setting or press **START** to initiate the pump.

Note:

- Volume is locked during **START Mode** and pressing **Selection Key** will display the current set volume.
- To clear preset volume at anytime, simultaneously press **Mute Key** and **Function Setting Key/Selection Key**

7.5.2 Setting Syringe Volume

- a. Press **Selection Key/Function Setting Key** twice. Display will show -01-.
- b. Using either **Fast Setting Keys** or **Fine Setting Keys** adjust the volume until desired volume is reached.
- c. Press **Selection Key** to go next setting or press **START** to initiate the pump (volume will flash three times on the display).

Note:

- Syringe volume does not need to be changed unless the different volume size syringe is used.

7.6 Displaying Total Volume

- a. To display total volume of buffer pumped into the column, press **Syringe Volume Key** (Σ) at anytime.
- b. To reset the displayed **Total Volume**, simultaneously press **Syringe Volume Key** and **Mute Key** at anytime.

7.7 System Pressure Selection

- a. Press **Selection Key** twice. Display will show OCCL.
- b. Using **Fine Setting Keys** select either High (H) or Low (L) pressure setting.
- c. Press **Selection Key** to go next setting or press **START** to initiate the pump (volume will flash three times on the display).

7.8 Automated Control Setup

EpiMAX™ Automated Pump includes a standard RS232 interface. For automated control of the pump, connect a compatible device (Standard IEC6090:1999) through the RS232 interface.

8.0 Maintenance

Maintenance Activity	Recommended Procedure	Recommended Schedule
Clean Pump Surface	Clean outside surface of pump with soft cloth. Use cleaning detergent, if necessary.	Daily/Weekly
Replace Fuse	Replacement of Fuse: Located rear cover of the pump. Loosen screws and remove the fuse holder. Replace with 0.5A (φ5×20) Fuse.	As Required
Replace Battery	Contact Epitomics	As Required

9.0 ALARM REFERENCE/TROUBLESHOOTING GUIDE

Alarm	Cause	Solution
NEA.EMPTY (Near Empty) Light On	Reagent volume in the Syringe is less than 1.5 ml	Press STOP Key and refill the syringe with reagent if necessary.
EMPTY Light On	Reagent volume in the Syringe is at zero.	Press STOP Key and refill the syringe with reagent if necessary.
Clogging/Over Pressure Light On	Column Clogged. Preset pressure level reached. (Note: with the increased output volume, the pressure of the system will increase gradually. When system pressure of the reaches preset pressure value, Alarm for Clogging/Over Pressure will be triggered.)	Press STOP key and release the pressure (change column or unclog column). Press MUTE Key to reset the pump.
Improper Syringe Clamping	Syringe Holding Clamp is not properly set. Syringe is not securely set into the Syringe Bed and/or Fixture Groove Body or Head.	Re-secure Syringe onto the Syringe Bed/Fixture Groove. Recheck Syringe Holding Clamp.
AC Power Failure On	Lost of AC Power to the Pump.	Check if the power cord is securely connected to the pump and to the power source. Check if power source is active.
Low Battery Light On	Low Battery Level (battery level is good for only ~30 minutes or less of operation time)	Recharge battery.
No Power from Battery Light On	No Battery Power	Recharge Battery.
Alarm Beeps Twice after initial start up	No operation of the pump initiated after 2 minutes	No Action Needed.

Problem	Cause	Solution
Inaccurate rate	The edge of syringe body is not properly connected to the groove fixture on the pump.	Follow correct procedure.
	Unrecognized syringe	Use standard disposable syringes with volume setting 20, 30, or 50 mls.
Alarm for the Low Battery upon startup	The battery is charged after previous Use, or placed for a long time after charging	Recharge battery immediately
	Improper use of build-in battery, the battery is damaged.	Replace the battery
Buffer back flow/ not flow upon Start	Before inserted needle tip into vein, mechanism gap is not cancelled by pressing FAST key.	Confirm no air is tapped in the tubing. Press FAST key and force buffer into Tubing.
	The edge of syringe body is not properly connected to the groove fixture on the pump.	Follow correct procedure.
	Tubing clogging	Replace tubing.
Unsmooth movement of Advancing Head	Clamp block is stuck	Clean clamp block with alcohol (e.g. 10% Isophrophol)

For additional information and technical inquiries please visit Epitomics website or contact technical services at (877) 772-2622, support@epitomics.com

10.0 RELATED PRODUCTS

Catalog #	Product Name	Size
6000-1	EpiMAX™ Affinity Purification Kit	N/A

11.0 CONTACT

Epitomics, Inc.
863 Mitten Road Suite 103
Burlingame, CA 94010-1303, U.S.A.
Phone: (877) 772-2622 (Toll Free North America);
(650) 583-6688
Fax: (650) 583-6680

13.0 DISCLAMINER/WARRANTY

Disclaimer

Epitomics, Inc. products are warranted to meet the applicable product specifications described. Notice of non-conforming products should be made to Epitomics, Inc. within 21 days of receipt of the product. Epitomics, Inc. disclaims any and all responsibility for any injury or damage which may be caused by the fault of the user or the buyer in accordance with the terms and conditions herein

WARRANTY COVERAGE

Epitomics' warranty obligations are limited to the terms set forth below: Epitomics, Inc. ("Epitomics") warrants this hardware product against defects in materials and workmanship for a period of ONE (1) YEAR from the date of original retail purchase. If a defect exists, at its option Epitomics will (1) repair the product at no charge, using new or refurbished replacement parts, (2) exchange the product with a product that is new or which has been manufactured from new or serviceable used parts and is at least functionally equivalent to the original product, or (3) refund the purchase price of the product. A replacement product/part assumes the remaining warranty of the original product or ninety (90) days from the date of replacement or repair, whichever provides longer coverage. Any shipping and handling charge incurred for any replacement, repair, and/or exchange will be the responsibility of the customer. When a product or part is exchanged, any replacement item becomes the customer's property and the replaced item becomes Epitomics' property. When a refund is given, the product becomes Epitomics' property. All components of the pump except for the battery is covered by this warranty. Technical documents listed in IEC60601-1, term 6.8.3C as upon customer's request.



Copyright Notices

The works of authorship contained in Epitomics Website, including but not limited to all design, text, images, and scientific data, are owned, except as otherwise expressly stated, by Epitomics, Inc. and its subsidiaries. Except as otherwise expressly stated herein, they may not be copied, transmitted, displayed, performed, distributed (for compensation or otherwise), licensed, altered, framed, stored for subsequent use or otherwise used in whole or in part in any manner without Epitomics, Inc.'s prior written consent, except to the extent permitted by the Copyright Act of 1976 (17 U.S.C. Section 107), as amended, and then, only with notices of Epitomics, Inc.'s proprietary rights provided that you may download information and print out hard copies for your personal use, so long as you do not remove any copyright or other notice as may be contained in information, as downloaded.

Trademark Notices

Epitomics, Epitomics symbol logo are the worldwide registered trademarks and service marks of Epitomics, Inc. Other featured words or symbols, used to identify the source of goods and services, may be the trademarks of their respective owners.