

PXI

NI PXI-8214 User Manual

Worldwide Technical Support and Product Information

ni.com

National Instruments Corporate Headquarters

11500 North Mopac Expressway Austin, Texas 78759-3504 USA Tel: 512 683 0100

Worldwide Offices

Australia 03 9879 5166, Austria 0662 45 79 90 0, Belgium 02 757 00 20, Brazil 55 11 3262 3599,
Canada (Calgary) 403 274 9391, Canada (Montreal) 514 288 5722, Canada (Ottawa) 613 233 5949,
Canada (Québec) 514 694 8521, Canada (Toronto) 905 785 0085, China 86 21 6555 7838,
Czech Republic 02 2423 5774, Denmark 45 76 26 00, Finland 09 725 725 11, France 01 48 14 24 24,
Germany 089 741 31 30, Greece 01 42 96 427, Hong Kong 2645 3186, India 91 80 4190000,
Israel 03 6393737, Italy 02 413091, Japan 03 5472 2970, Korea 02 3451 3400, Malaysia 603 9596711,
Mexico 001 800 010 0793, Netherlands 0348 433466, New Zealand 09 914 0488, Norway 32 27 73 00,
Poland 22 3390 150, Portugal 210 311 210, Russia 095 238 7139, Singapore 65 6 226 5886,
Slovenia 3 425 4200, South Africa 11 805 8197, Spain 91 640 0085, Sweden 08 587 895 00,
Switzerland 056 200 51 51, Taiwan 02 2528 7227, United Kingdom 01635 523545

For further support information, refer to the *Technical Support and Professional Services* appendix. To comment on the documentation, send email to techpubs@ni.com.

© 2002 National Instruments Corporation. All rights reserved.

Important Information

Warranty

The NI PXI-8214 is warranted against defects in materials and workmanship for a period of one year from the date of shipment, as evidenced by receipts or other documentation. National Instruments will, at its option, repair or replace equipment that proves to be defective during the warranty period. This warranty includes parts and labor.

The media on which you receive National Instruments software are warranted not to fail to execute programming instructions, due to defects in materials and workmanship, for a period of 90 days from date of shipment, as evidenced by receipts or other documentation. National Instruments will, at its option, repair or replace software media that do not execute programming instructions if National Instruments receives notice of such defects during the warranty period. National Instruments does not warrant that the operation of the software shall be uninterrupted or error free.

A Return Material Authorization (RMA) number must be obtained from the factory and clearly marked on the outside of the package before any equipment will be accepted for warranty work. National Instruments will pay the shipping costs of returning to the owner parts which are covered by warranty.

National Instruments believes that the information in this document is accurate. The document has been carefully reviewed for technical accuracy. In the event that technical or typographical errors exist, National Instruments reserves the right to make changes to subsequent editions of this document without prior notice to holders of this edition. The reader should consult National Instruments if errors are suspected. In no event shall National Instruments be liable for any damages arising out of or related to this document or the information contained in it.

EXCEPT AS SPECIFIED HEREIN, NATIONAL INSTRUMENTS MAKES NO WARRANTIES, EXPRESS OR IMPLIED, AND SPECIFICALLY DISCLAIMS ANY WARRANTY OF MERCHANTABILITY OR FITNESS FOR A PARTICULAR PURPOSE. CUSTOMER'S RIGHT TO RECOVER DAMAGES CAUSED BY FAULT OR NEGLIGENCE ON THE PART OF NATIONAL INSTRUMENTS SHALL BE LIMITED TO THE AMOUNT THEREOF PAID BY THE CUSTOMER. NATIONAL INSTRUMENTS WILL NOT BE LIABLE FOR DAMAGES RESULTING FROM LOSS OF DATA, PROFITS, USE OF PRODUCTS, OR INCIDENTAL OR CONSEQUENTIAL DAMAGES, EVEN IF ADVISED OF THE POSSIBILITY THEREOF. This limitation of the liability of National Instruments will apply regardless of the form of action, whether in contract or tort, including negligence. Any action against National Instruments must be brought within one year after the cause of action accrues. National Instruments shall not be liable for any delay in performance due to causes beyond its reasonable control. The warranty provided herein does not cover damages, defects, malfunctions, or service failures caused by owner's failure to follow the National Instruments installation, operation, or maintenance instructions; owner's modification of the product; owner's abuse, misuse, or negligent acts; and power failure or surges, fire, flood, accident, actions of third parties, or other events outside reasonable control.

Copyright

Under the copyright laws, this publication may not be reproduced or transmitted in any form, electronic or mechanical, including photocopying, recording, storing in an information retrieval system, or translating, in whole or in part, without the prior written consent of National Instruments Corporation.

Trademarks

National Instruments™, NI™, and ni.com™ are trademarks of National Instruments Corporation.

Product and company names mentioned herein are trademarks or trade names of their respective companies.

Patents

For patents covering National Instruments products, refer to the appropriate location: **Help»Patents** in your software, the `patents.txt` file on your CD, or `ni.com/patents`.

WARNING REGARDING USE OF NATIONAL INSTRUMENTS PRODUCTS

(1) NATIONAL INSTRUMENTS PRODUCTS ARE NOT DESIGNED WITH COMPONENTS AND TESTING FOR A LEVEL OF RELIABILITY SUITABLE FOR USE IN OR IN CONNECTION WITH SURGICAL IMPLANTS OR AS CRITICAL COMPONENTS IN ANY LIFE SUPPORT SYSTEMS WHOSE FAILURE TO PERFORM CAN REASONABLY BE EXPECTED TO CAUSE SIGNIFICANT INJURY TO A HUMAN.

(2) IN ANY APPLICATION, INCLUDING THE ABOVE, RELIABILITY OF OPERATION OF THE SOFTWARE PRODUCTS CAN BE IMPAIRED BY ADVERSE FACTORS, INCLUDING BUT NOT LIMITED TO FLUCTUATIONS IN ELECTRICAL POWER SUPPLY, COMPUTER HARDWARE MALFUNCTIONS, COMPUTER OPERATING SYSTEM SOFTWARE FITNESS, FITNESS OF COMPILERS AND DEVELOPMENT SOFTWARE USED TO DEVELOP AN APPLICATION, INSTALLATION ERRORS, SOFTWARE AND HARDWARE COMPATIBILITY PROBLEMS, MALFUNCTIONS OR FAILURES OF ELECTRONIC MONITORING OR CONTROL DEVICES, TRANSIENT FAILURES OF ELECTRONIC SYSTEMS (HARDWARE AND/OR SOFTWARE), UNANTICIPATED USES OR MISUSES, OR ERRORS ON THE PART OF THE USER OR APPLICATIONS DESIGNER (ADVERSE FACTORS SUCH AS THESE ARE HEREAFTER COLLECTIVELY TERMED "SYSTEM FAILURES"). ANY APPLICATION WHERE A SYSTEM FAILURE WOULD CREATE A RISK OF HARM TO PROPERTY OR PERSONS (INCLUDING THE RISK OF BODILY INJURY AND DEATH) SHOULD NOT BE RELIANT SOLELY UPON ONE FORM OF ELECTRONIC SYSTEM DUE TO THE RISK OF SYSTEM FAILURE. TO AVOID DAMAGE, INJURY, OR DEATH, THE USER OR APPLICATION DESIGNER MUST TAKE REASONABLY PRUDENT STEPS TO PROTECT AGAINST SYSTEM FAILURES, INCLUDING BUT NOT LIMITED TO BACK-UP OR SHUT DOWN MECHANISMS. BECAUSE EACH END-USER SYSTEM IS CUSTOMIZED AND DIFFERS FROM NATIONAL INSTRUMENTS' TESTING PLATFORMS AND BECAUSE A USER OR APPLICATION DESIGNER MAY USE NATIONAL INSTRUMENTS PRODUCTS IN COMBINATION WITH OTHER PRODUCTS IN A MANNER NOT EVALUATED OR CONTEMPLATED BY NATIONAL INSTRUMENTS, THE USER OR APPLICATION DESIGNER IS ULTIMATELY RESPONSIBLE FOR VERIFYING AND VALIDATING THE SUITABILITY OF NATIONAL INSTRUMENTS PRODUCTS WHENEVER NATIONAL INSTRUMENTS PRODUCTS ARE INCORPORATED IN A SYSTEM OR APPLICATION, INCLUDING, WITHOUT LIMITATION, THE APPROPRIATE DESIGN, PROCESS AND SAFETY LEVEL OF SUCH SYSTEM OR APPLICATION.

Compliance

FCC/Canada Radio Frequency Interference Compliance

Determining FCC Class

The Federal Communications Commission (FCC) has rules to protect wireless communications from interference. The FCC places digital electronics into two classes. These classes are known as Class A (for use in industrial-commercial locations only) or Class B (for use in residential or commercial locations). Depending on where it is operated, this product could be subject to restrictions in the FCC rules. (In Canada, the Department of Communications (DOC), of Industry Canada, regulates wireless interference in much the same way.)

Digital electronics emit weak signals during normal operation that can affect radio, television, or other wireless products. By examining the product you purchased, you can determine the FCC Class and therefore which of the two FCC/DOC Warnings apply in the following sections. (Some products may not be labeled at all for FCC; if so, the reader should then assume these are Class A devices.)

FCC Class A products only display a simple warning statement of one paragraph in length regarding interference and undesired operation. Most of our products are FCC Class A. The FCC rules have restrictions regarding the locations where FCC Class A products can be operated.

FCC Class B products display either a FCC ID code, starting with the letters **EXN**, or the FCC Class B compliance mark that appears as shown here on the right.

Consult the FCC Web site at <http://www.fcc.gov> for more information.

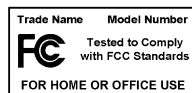

FCC/DOC Warnings

This equipment generates and uses radio frequency energy and, if not installed and used in strict accordance with the instructions in this manual and the CE Marking Declaration of Conformity*, may cause interference to radio and television reception. Classification requirements are the same for the Federal Communications Commission (FCC) and the Canadian Department of Communications (DOC).

Changes or modifications not expressly approved by National Instruments could void the user's authority to operate the equipment under the FCC Rules.

Class A

Federal Communications Commission

This equipment has been tested and found to comply with the limits for a Class A digital device, pursuant to part 15 of the FCC Rules. These limits are designed to provide reasonable protection against harmful interference when the equipment is operated in a commercial environment. This equipment generates, uses, and can radiate radio frequency energy and, if not installed and used in accordance with the instruction manual, may cause harmful interference to radio communications. Operation of this equipment in a residential area is likely to cause harmful interference in which case the user will be required to correct the interference at his own expense.

Canadian Department of Communications

This Class A digital apparatus meets all requirements of the Canadian Interference-Causing Equipment Regulations.

Cet appareil numérique de la classe A respecte toutes les exigences du Règlement sur le matériel brouilleur du Canada.

Class B

Federal Communications Commission

This equipment has been tested and found to comply with the limits for a Class B digital device, pursuant to part 15 of the FCC Rules. These limits are designed to provide reasonable protection against harmful interference in a residential installation. This equipment generates, uses, and can radiate radio frequency energy and, if not installed and used in accordance with the instructions, may cause harmful interference to radio communications. However, there is no guarantee that interference will not occur in a particular installation. If this equipment does cause harmful interference to radio or television reception, which can be determined by turning the equipment off and on, the user is encouraged to try to correct the interference by one or more of the following measures:

- Reorient or relocate the receiving antenna.
- Increase the separation between the equipment and receiver.
- Connect the equipment into an outlet on a circuit different from that to which the receiver is connected.
- Consult the dealer or an experienced radio/TV technician for help.

Canadian Department of Communications

This Class B digital apparatus meets all requirements of the Canadian Interference-Causing Equipment Regulations.

Cet appareil numérique de la classe B respecte toutes les exigences du Règlement sur le matériel brouilleur du Canada.

Compliance to EU Directives

Readers in the European Union (EU) must refer to the Manufacturer's Declaration of Conformity (DoC) for information* pertaining to the CE Marking compliance scheme. The Manufacturer includes a DoC for most every hardware product except for those bought for OEMs, if also available from an original manufacturer that also markets in the EU, or where compliance is not required as for electrically benign apparatus or cables.

To obtain the DoC for this product, click **Declaration of Conformity** at ni.com/hardref.nsf/. This Web site lists the DoCs by product family. Select the appropriate product family, followed by your product, and a link to the DoC appears in Adobe Acrobat format. Click the Acrobat icon to download or read the DoC.

* The CE Marking Declaration of Conformity will contain important supplementary information and instructions for the user or installer.

Conventions

The following conventions are used in this manual:

»

The » symbol leads you through nested menu items and dialog box options to a final action. The sequence **File»Page Setup»Options** directs you to pull down the **File** menu, select the **Page Setup** item, and select **Options** from the last dialog box.



This icon denotes a note, which alerts you to important information.



This icon denotes a caution, which advises you of precautions to take to avoid injury, data loss, or a system crash.

bold

Bold text denotes items that you must select or click in the software, such as menu items and dialog box options. Bold text also denotes parameter names.

italic

Italic text denotes variables, emphasis, a cross reference, or an introduction to a key concept. This font also denotes text that is a placeholder for a word or value that you must supply.

monospace

Text in this font denotes text or characters that you should enter from the keyboard, sections of code, programming examples, and syntax examples. This font is also used for the proper names of disk drives, paths, directories, programs, subprograms, subroutines, device names, functions, operations, variables, filenames and extensions, and code excerpts.

Contents

Chapter 1

Hardware Overview

PXI-8214 Features	1-1
Connectivity	1-2
Connectors	1-2

Chapter 2

Installation

What You Need to Get Started	2-1
Installing the PXI-8214	2-1
Driver Installation	2-3
Windows XP	2-3
Windows 2000	2-3
Windows NT	2-3
Windows 98	2-4
Linux	2-4
Device Connection Guide	2-4
Termination Configuration	2-6

Appendix A

Specifications

Appendix B

Technical Support and Professional Services

Hardware Overview

The NI PXI-8214 PXI-to-Ultra2 SCSI Host Adapter provides an Ultra2 SCSI interface to PXI or CompactPCI (cPCI) systems. The PXI-8214 is a 16-bit Low Voltage Differential (LVD)/Single-Ended (SE) SCSI solution you can use to connect up to 15 SCSI devices. Data transfer rates of up to 40 MegaTransfers (MT)/s (80 Mbytes/s) are possible. The PXI-8214 is an ideal solution for the PXI/cPCI system that requires true high-speed continuous disk operation.

PXI-8214 Features

The PXI-8214 includes the following features:

- LSI53C895A PXI-to-Ultra2 SCSI controller
- PXI/cPCI interface
 - Supports 32-bit DMA bus master with 64-bit addressing
 - Bursts up to 133 Mbytes/s at 33 MHz with zero wait-state bus master data
- SCSI interface
 - Supports 16-bit LVD and SE signaling
 - Contains 68-pin high-density (HD) connector
 - Performs wide (16-bit) Ultra2, synchronous LVD, SCSI transfers up to 40 MT/s
 - Supports up to 15 SCSI devices
 - Maximum cable length for point-to-point connections—25 m
 - Has active termination for one end of the SCSI bus
 - Provides SCSI termination power source
 - Onboard flash ROM for storage of SCSI BIOS
 - SCSI bus activity LED

Connectivity

The PXI-8214 connects up to 15 SCSI devices, including CD-ROM drives, hard disks, printers, and scanners. This interface can support single-ended and low voltage differential (LVD) devices.

Connectors

There are two connectors. Connector P1 is a cPCI backplane connector; connector J1 is a 68-contact alternative 3 shielded SCSI device connector.

Installation

This chapter explains how to install the PXI-8214.

What You Need to Get Started

- PXI or cPCI system
- PXI-8214 interface board
- Driver for PXI-8214 (diskettes are included for Windows 2000 and Windows NT; Windows XP has native support; you can download drivers for Windows 98, Linux, and other operating systems from the National Instruments Web site at ni.com/support)
- SCSI cable
- SCSI device
- SCSI terminator (may be part of SCSI device)

Installing the PXI-8214



Caution Electrostatic discharge can damage several components on the PXI-8214. To avoid such damage in handling the board, touch the antistatic plastic package to a metal part of your system chassis before removing the board from the package.

Complete the following steps to install the PXI-8214:

1. Make sure your system is turned off. Keep the system plugged in so that it remains grounded while you install the PXI-8214.
2. Choose an unused PXI/cPCI slot in your system. The PXI-8214 requires a slot that supports bus arbitration or bus master cards.
3. Remove the slot cover for the slot you have chosen.
4. Make sure the injector/ejector handle is in its downward position. Align the PXI-8214 with the card guides on the top and bottom of the slot.



Caution Do not raise the injector/ejector handle as you insert the PXI-8214. The module will not insert properly unless the handle is in its downward position so that it does not interfere with the injector rail on the chassis.

5. Hold the handle as you slowly slide the module into the chassis until the handle catches on the injector/ejector rail.
6. Raise the injector/ejector handle until the module firmly seats into the backplane receptacle connectors. The front panel of the PXI-8214 should be even with the chassis front panel.

Figure 2-1 shows how to install the PXI-8214 in a PXI/CompactPCI chassis.

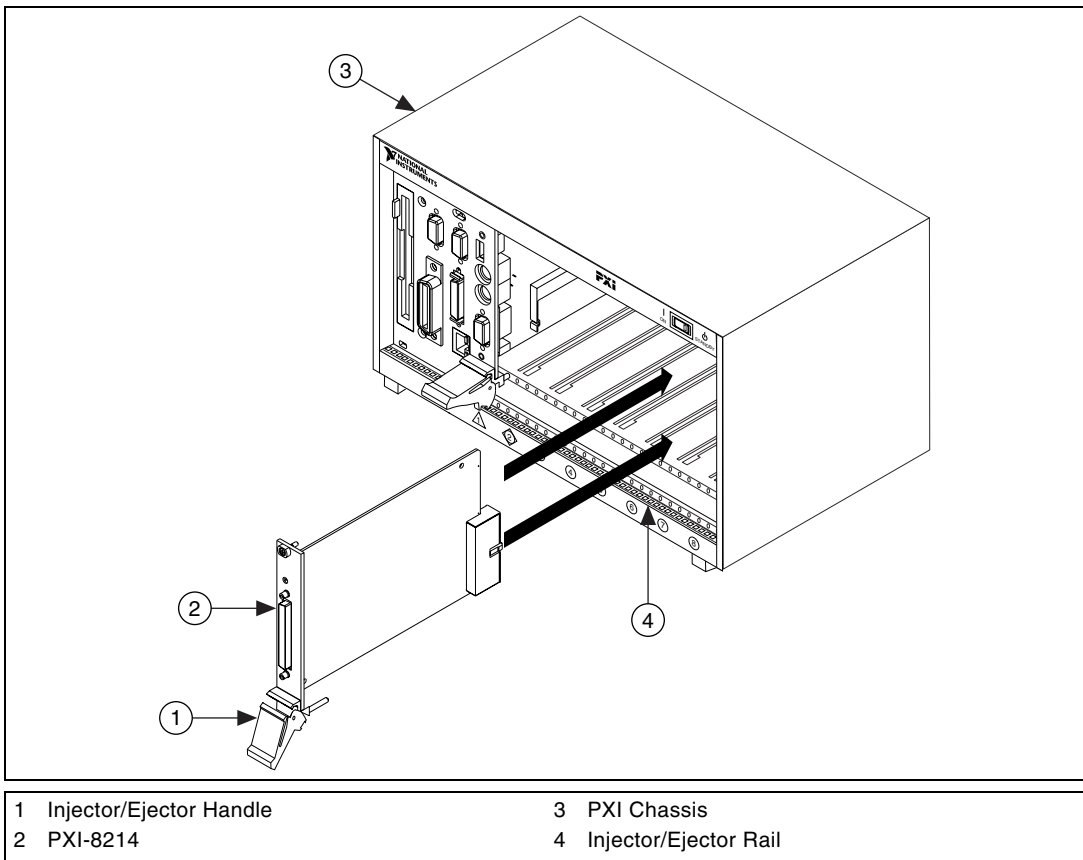

Figure 2-1. Installing the PXI-8214 into a PXI/CompactPCI Chassis

7. Screw the front panel of the PXI-8214 to the front panel mounting rail.
8. Power on your system.

Driver Installation

Windows XP

The PXI-8214 should automatically install with the correct driver. You can verify installation in the Device Manager.

After verifying that your operating system recognizes the PXI-8214 properly, power down your system and connect your devices according to the [Device Connection Guide](#) section.

Windows 2000

Installation in an Existing Operating System

1. In the New Hardware Found Wizard, select **Search for a suitable driver for my device** and click **Next**.
2. Check the **Floppy Disk** box and insert the Windows 2000 driver diskette into your floppy disk drive.
3. Windows 2000 should find the proper driver. You can verify installation in the Device Manager.

After verifying that your operating system recognizes the PXI-8214 properly, power down your system and connect your devices according to the [Device Connection Guide](#) section.

New System Installation

Refer to the installation instructions in the WIN2000.TXT file on the *NI PXI-8214 Driver for Windows 2000* disk.

Windows NT

Installation in an Existing Operating System

1. In the Control Panel, double-click the **SCSI Adapters** icon.
2. Select the **Drivers** tab and click the **Add** button. In the box that appears, click the **Have Disk...** button.
3. Point the dialog box to the winnt/miniport/ directory on your floppy disk.
4. After you select the oemsetup.inf file, you will be prompted to restart your computer.

5. You can verify the installation by returning to the Control Panel and double-clicking **SCSI Adapters**.

After verifying that your operating system recognizes the PXI-8214 properly, power down your system and connect your devices according to the *Device Connection Guide* section.

New System Installation

Refer to the installation instructions in the WINNT.TXT file on the *NI PXI-8214 Driver for Windows NT 4.0* disk.

Windows 98

1. In the Add New Hardware Wizard, select **Search for the best driver for your device**.
2. If your driver is on a floppy disk, select that option. If not, point the wizard to the driver location.
3. Windows 98 should find the proper driver file. You can verify installation in the Device Manager.

After verifying that your operating system recognizes the PXI-8214 properly, power down your system and connect your devices according to the *Device Connection Guide* section.

Linux

Instructions for installing under Linux depend on the Linux kernel you are using. Refer to the `readme.txt` file included with the driver for instructions for your particular kernel. The PXI-8214 uses the LSI53C895A PCI-to-Ultra2 SCSI controller.

After verifying that your operating system recognizes the PXI-8214 properly, power down your system and connect your devices according to the *Device Connection Guide* section.

Device Connection Guide

Each device on the SCSI bus must have a unique device number. The PXI-8214 has device number 7. Other devices on the bus must have their own unique number. For most devices, the user sets this device number with onboard switches. The device numbers do not need to be in any particular order, but they do need to be unique.

Both ends of the SCSI bus must be terminated. The PXI-8214 default configuration terminates one end of the SCSI bus. (To change this configuration, refer to the [Termination Configuration](#) section.) The other end of your SCSI bus must be terminated also. Many SCSI devices have onboard termination that can be enabled, or you can add an external terminator to the end of the bus. Improper termination can cause unpredictable bus operation.



Cautions The PXI 8214 is a 16-bit SCSI interface using active termination that fully terminates one end of the 16-bit SCSI bus. The user must provide termination for the other bus end.

You can use 8-bit devices (such as most SCSI CD-ROMs), but you must be careful when cabling and terminating these devices. If only 8-bit devices reside on the SCSI bus, you can use the 8-bit termination on those devices as the end termination.

However, if both 8-bit and 16-bit devices are used, end termination must be from either a 16-bit device at the end of the bus or an external 16-bit terminator. Terminating a 16-bit SCSI bus with an 8-bit device can result in unpredictable bus operation.

Each device must have at least 0.1 m (3.93 in.) of cabling between them. When connecting more than one device, you must use a daisy-chain configuration. A star configuration is not allowed.

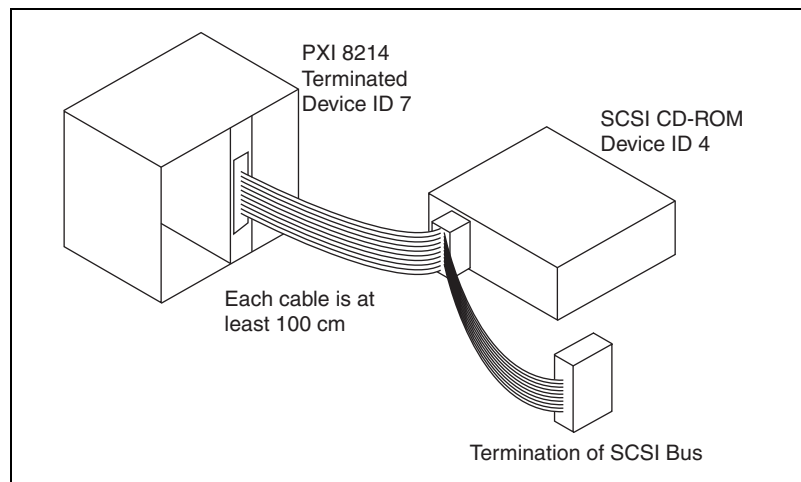

Figure 2-2. Single SCSI Device with Independent Termination

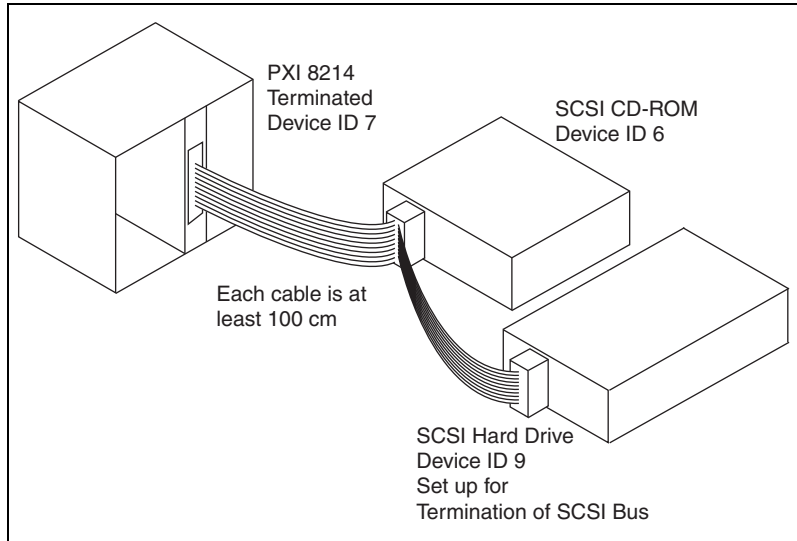

Figure 2-3. Multiple SCSI Devices with Termination Handled by the Last SCSI Device on the Bus

Termination Configuration

In the default configuration shown in Figure 2-4, the PXI-8214 switches SW1-1 and SW1-2 are both set to ON to terminate the SCSI bus. In most applications, you should use the default configuration. To disable termination on the PXI-8214, you must set both the SW1-1 and SW1-2 switches to the OFF position. In all setups, both switches should be either ON or OFF. If the switches are mismatched, the board will function incorrectly.

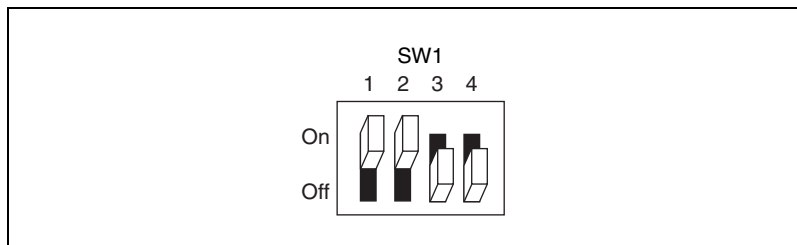

Figure 2-4. SW1 Default Configuration

Specifications

This appendix lists the electrical, mechanical, environmental, safety, and compliance specifications of the PXI-8214.

Electrical

Voltage (V)	Current	
	Typical	Maximum
+3.3	225 mA	300 mA
+5	150 mA	500 mA

Physical

Board dimensions.....	10.0 by 16.0 cm (3.9 by 6.3 in.)
Slot requirements	One peripheral slot
Weight.....	0.13 kg (0.28 lb)
Temperature	0 to 50 °C, operating –20 to 70 °C, storage
Relative humidity	10 to 90% noncondensing, operating 5 to 95% noncondensing, storage
Functional shock	30 g peak, half-sine, 11 ms pulse
Random vibration.....	5 to 500 Hz, 0.3 g _{rms} , operating 5 to 500 Hz, 2.4 g _{rms} , nonoperating

Safety

This product is designed to meet the requirements of the following standards of safety for electrical equipment for measurement, control, and laboratory use:

- IEC 61010-1, EN 61010-1
- UL 3121-1
- CAN/CSA C22.2 No. 1010.1



Note For UL and other safety certifications, refer to the product label or ni.com.

Electromagnetic Compatibility

EMC/EMICE, C-Tick, and FCC Part 15
(Class A) Compliant

Electromagnetic emissionsEN 55011 Class A at 10 meters
FCC Part 15A above 1 GHz

Electromagnetic immunityEvaluated to EN 61326:1997/
A1:1998, Table 1



Note For EMC compliance, operate this device with shielded cabling.

CE Compliance

This product meets the essential requirements of applicable European Directives, as amended for CE Marking, as follows:

- Low-Voltage Directive (safety): 73/23/EEC
- Electromagnetic Compatibility Directive (EMC): 89/336/EEC



Note See the **Declaration of Conformity (DoC)** for this product at ni.com for any additional regulatory compliance information. You can find the DoC using the search utility and product model number.

Technical Support and Professional Services

Visit the following sections of the National Instruments Web site at ni.com for technical support and professional services:

- **Support**—Online technical support resources include the following:
 - **Self-Help Resources**—For immediate answers and solutions, visit our extensive library of technical support resources available in English, Japanese, and Spanish at ni.com/support. These resources are available for most products at no cost to registered users and include software drivers and updates, a KnowledgeBase, product manuals, step-by-step troubleshooting wizards, hardware schematics and conformity documentation, example code, tutorials and application notes, instrument drivers, discussion forums, a measurement glossary, and so on.
 - **Assisted Support Options**—Contact NI engineers and other measurement and automation professionals by visiting ni.com/ask. Our online system helps you define your question and connects you to the experts by phone, discussion forum, or email.
- **Training**—Visit ni.com/custed for self-paced tutorials, videos, and interactive CDs. You also can register for instructor-led, hands-on courses at locations around the world.
- **System Integration**—If you have time constraints, limited in-house technical resources, or other project challenges, NI Alliance Program members can help. To learn more, call your local NI office or visit ni.com/alliance.

If you searched ni.com and could not find the answers you need, contact your local office or NI corporate headquarters. Phone numbers for our worldwide offices are listed at the front of this manual. You also can visit the Worldwide Offices section of ni.com/niglobal to access the branch office Web sites, which provide up-to-date contact information, support phone numbers, email addresses, and current events.