

HDSDI-CHO-2x1 HD-SDI-CHO-2x1-PB

HD-SDI Change-over 2x1

User manual

Rev. 6

Nevion Support

Nevion Europe

P.O. Box 1020
3204 Sandefjord, Norway
Support phone 1: +47 33 48 99 97
Support phone 2: +47 90 60 99 99

Nevion USA

1600 Emerson Avenue
Oxnard, CA 93033, USA
Toll free North America: (866) 515-0811
Outside North America: +1 (805) 247-8560

E-mail: support@nevision.com

See <http://www.nevision.com/support/> for service hours for customer support globally.

Revision history

Current revision of this document is the uppermost in the table below.

Rev.	Repl.	Date	Sign	Change description
6	5	2010-06-14	SHH	Added passive bypass option to manual in Chapter 1 and 4. Updated GPI table and description Chapter 5 to new Status functionality. Updated Declaration of Conformity.
5	4	2010-04-08	NBS	Corrected table in Chapter 6.
4	3	2008-07-15	AS	Added Declaration of Conformity
3	2	2007-10-26	NBS	New front page.
2	1	2007-10-08	NBS	Added Materials Declaration and EFUP.
1	0	2006-08-10		New firmware revision has another timer and slightly different latch.
0	A	2005-04-07		First released version.

Contents

- 1 Product overview 4
 - 1.1 Product description 4
 - 1.2 Product versions 4
- 2 Specifications 5
 - 2.1 Electrical input 5
 - 2.2 Electrical output 5
 - 2.3 Features 5
 - 2.4 Electrical 5
 - 2.5 Supported standards 5
- 3 Format Configuration 6
 - 3.1 Configuration examples 7
- 4 Connections 8
- 5 Module status 9
 - 5.1 GPI alarm and control – Module status outputs and selection of inputs 9
 - 5.2 Front panel - Status monitoring 10
- 6 Interface with GYDA and RS-422 command set 11
- Appendix A Materials declaration and recycling information 14

1 Product overview

1.1 Product description

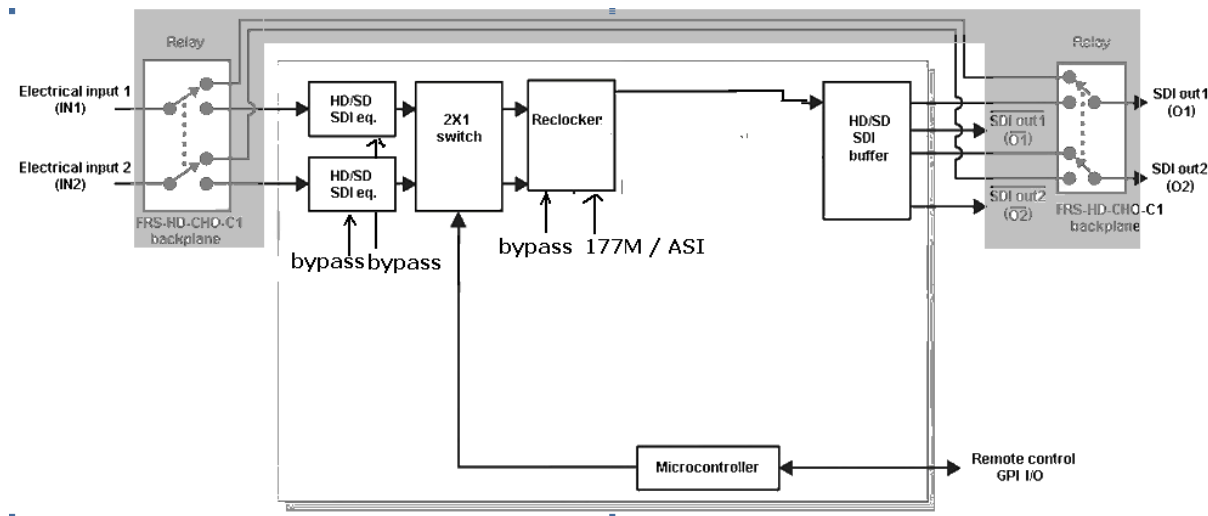

Figure 1: HDSDI-CHO-2x1(-PB) functional overview

The Flashlink HDSDI-CHO-2x1 is a serial digital video 2x1 change-over module providing high performance line protection for various signal formats from 1Mbps up to 1485Mbps. The unit can be configured to perform cable equalizing and re-clocking of SMPTE 292M, SMPTE 259M and DVB-ASI signal formats. The switching criteria can be selected to be based on loss of input signal or loss of lock (re-clocker). The switch can either be latching or non-latching (in loss of lock mode, only latching switch is available). It is also possible to control the switch with GPI inputs, with the GYDA system controller or with the open protocol RS422 interface.

The two inputs typically provide automatic cable equalizers for up to 250 meters of cable (Belden 8281A at 270Mbps) with a 2 x 1 switch in front of a re-clocker with 4 outputs. The re-clocker supports the bit-rates; 143, 177, 270, 360, 540 and 1485Mbps. For other rates, the re-clocker automatically switches to bypass mode and the HDSDI-CHO-2x1 will work as a non-reclocking 2x1 change-over unit with cable equalizer. The HDSDI-CHO-2x1 also has a special DVB-ASI mode, enabling all possible rates including empty transport streams with only K28.5 padding packets. 2 outputs are non-inverting to support DVB-ASI compatibility.

The HDSDI-CHO-2x1 is designed for various line protection applications for studio, campus, broadcast and telecom.

New in firmware version 2.0.0 or newer: When latched to standby input, latch will not hold against missing signal on standby input if the signal on main input has been restored. Also, a secondary timer has been added, which handles debouncing of the “signal on main input returns” condition. The primary timer handles debouncing of LOS on both main and standby inputs.

1.2 Product versions

HDSDI-CHO-2x1 2x1 HD/SD-SDI changeover

HDSDI-CHO-2x1-PB 2x1 HD/SD-SDI change over with passive bypass

2 Specifications

2.1 Electrical input

Number of inputs:	2.
Data rate NRZ:	1 – 1485 Mbps.
Equalization:	Automatic; Cable reclocker can be bypassed to support bit rates down to 1Mbps.
Impedance:	75 ohm
Return loss:	≤15dB @ 1485MHz.
Signal level:	nom. 800mV; Approximately 200mV min. when equalizer switched to Bypass.
Connector:	BNC.

2.2 Electrical output

Number of outputs:	4.
Connector:	BNC.
Impedance:	75 ohm.
Return loss:	≤15dB @ 1485MHz.
Jitter:	< 0.2UI.
Peak to peak signal level:	0.8V +/- 0.1V.
Signal polarity	2 outputs non-inverting, 2 outputs inverting.

2.3 Features

Re-clocking:	Automatic clock rate detection; Supported clock rates: 143, 177, 270, 360, 540 and 1485 Mbps.
--------------	--

2.4 Electrical

Power:	+5V DC / 3W Max.
Control:	Control system for access to setup and module status with BITE (Built-In Test Equipment) for use with GYDA Control System.

2.5 Supported standards

SMPTE:	SMPTE292M, SMPTE259M, SMPTE305.2M, SMPTE310M, SMPTE344M
DVB-ASI:	EN50083-9

3 Format Configuration

The HDSDI-CHO-2x1 can support a number of different formats. The correct configuration can either be set with a DIP switch or with the GYDA Control System. The layout of HDSDI-CHO-2x1 is shown in the drawing below with the DIP switch to the upper left position.

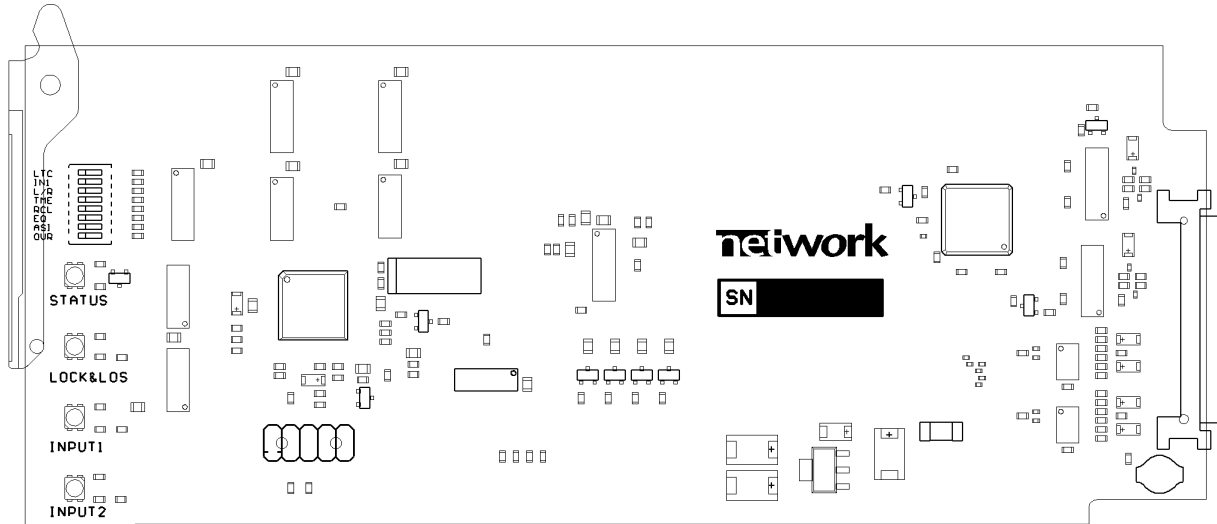

Figure 2: HDSDI-CHO-2x1 board layout

DIP switch configuration must be set according to the table below:

Switch #	Label	Function DIP=OFF	Function DIP=ON	Comment
1	LTC	Non-latching switch. Will automatically return to main when input signal present	Latching switch. Must be reset to return from standby to main	“Sticky” switching
2	IN1	Input 2 priority	Input 1 priority	Select main input
3	L/R	Loss of signal based switch decision	Reclocker based switch decision	Signal integrity decision
4	TME	Ripple rejection OFF	Ripple rejection ON (variable delay)	Timing
5	RCL	Reclocker Bypass	Reclocker ON	Reclocker mode
6	EQ	Cable equalizer Bypass. (Loss of signal based switch decision will not work on this mode)	Cable equalizer ON	Equalizer mode
7	ASI	SDI 177Mbps Reclocker support	DVB-ASI Reclocker support	ASI mode
8	OVR	GYDA control. Config. with GYDA	Override GYDA control. Config. with DIP switch	Select GYDA config. mode

All DIP switches are off when pointing towards the release handle.

When the default setting is selected, all clock rates for HD, SD and DVB-ASI are automatically configured by the module itself.

3.1 Configuration examples

Typical configurations for HDSDI-CHO-2x1:

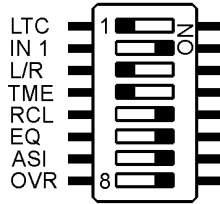

**Figure 3: Default for HD, SD or DVB-ASI;
Non-latching, Input1=main, LOS based, Reclocking, Ripple rejection OFF**

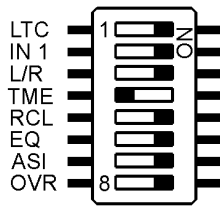
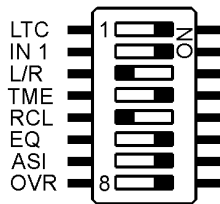

Figure 4: SD or DVB-ASI; Latching, Reclocker based decision



**Figure 5: Transparent Mode for Non-supported rates with Ripple rejection timer;
Latching, LOS based decision, Time ON, reclocking OFF**

4 Connections

The HDSDI-CHO-2x1 and HDSDI-CHO-2x1-PB has dedicated connector modules, SDI-CHO-2x1-C1 and FRS-HD-CHO-C1. These modules are mounted at the rear of the sub-rack. The modules are shown in the figure below.

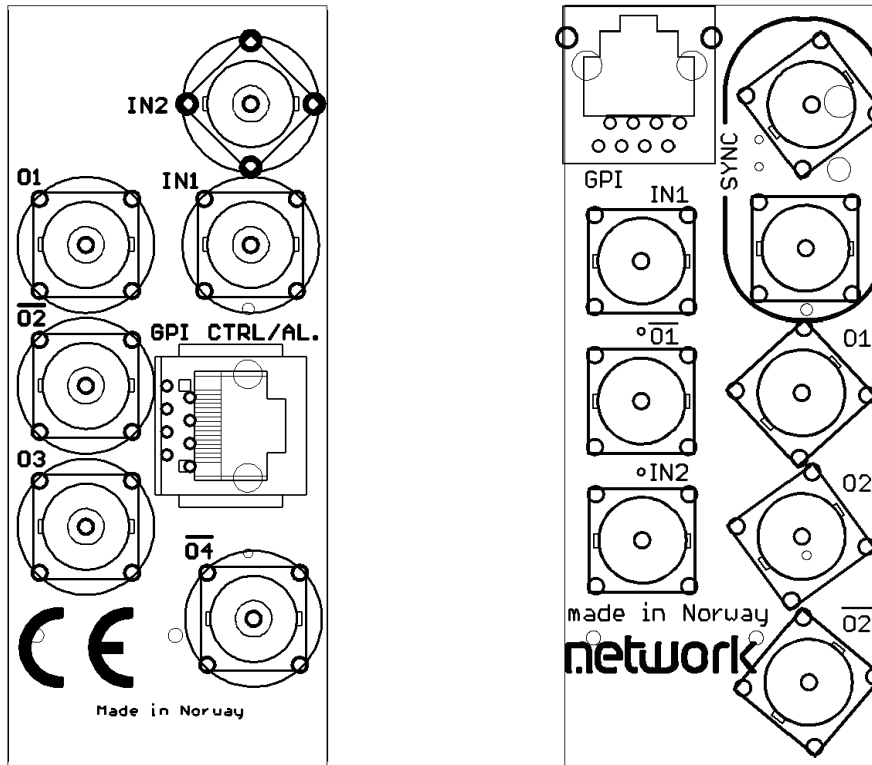

Figure 6: SDI-CHO-2X1-C1

FRS-HD-CHO C1

The electrical input signals are connected to the IN1 and IN2 BNC's. The electrical outputs are connected to the O1 to O4 BNC's. Please note that only 2 outputs are non-inverted and suitable for DVB-ASI. The Sync input connectors are not in use on this product.

The details of how the connector module is mounted, is found in the user manual for the sub-rack frame FR-2RU-10-2-xx.

This manual is also available from our web site: <http://www.nevion.com/>

5 Module status

The status of the module can be monitored in three ways.

1. GYDA System Controller (optional).
2. GPI at the rear of the sub-rack.
3. LED's at the front of the sub-rack.

Of these three, the GPI and the LED's are mounted on the module itself, whereas the GYDA System Controller is a separate module giving detailed information on the card status. The functions of the GPI and the LED's are described in sections 5.1 and 5.2. The GYDA controller is described in a separate user manual.

5.1 GPI alarm and control – Module status outputs and selection of inputs

These outputs can be used for wiring up alarms for third party control systems. The GPI outputs are open collector outputs, sinking to ground when an alarm is triggered. The GPI connector is shown in the figure below.

As of hardware version 4 or newer of the product, the Status signal is inverted, sinking to ground when signal is good. Earlier versions have a non-inverted Status signal.

The two GPI inputs can be used to control switching of inputs.

Electrical Maximums for GPI outputs

Max current: 100mA
Max voltage: 30V

HDSDI-CHO-2X1 module GPI pinning:

Signal	Name	Pin #	Mode	Direction
Status	General error status for the module	Pin 1	Inverted Open Collector	Output
LOS	Loss Of Signal at selected input	Pin 2	Open Collector	Output
Input 1	Input 1 selected (IN1)	Pin 3	Open Collector	Output
Input 2	Input 2 selected (IN2)	Pin 4	Open Collector	Output
Reset	Reset selected input to main	Pin 5	TTL, 0V = active level	Input
Set	Set selected input to standby	Pin 6	TTL, 0V = active level	Input
Ground	0 volt pin	Pin 8	0V.	

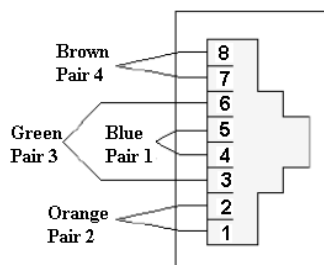
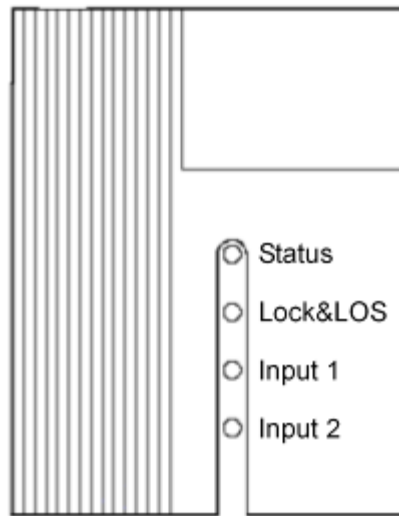

Figure 7: GPI Outlet

5.2 Front panel - Status monitoring

The status of the module can be easily monitored visually by the LED's at the front of the module. The LED's are visible through the front panel as shown in the figure below.



**Figure 8: indicator overview for HDSOI-CHO-2x1;
(Text not printed on the front panel)**

The HDSOI-CHO-2x1 has 4 LED's each showing a status corresponding to the GPI pinning. The position of the different LED's is shown in the figure above.

Diode \ state	Red LED	Yellow LED	Green LED	No light
Status	Module is faulty		Module is OK; Module power is OK	Module has no power
Lock&LOS	Loss Of Signal & No Reclocker lock	Signal present & No Reclocker lock	Signal present & Reclocker in lock	
Input 1	No input signal on Input 1	Signal present & not selected	Signal present & Input 1 selected	
Input 2	No input signal on Input 2	Signal present & not selected	Signal present & Input 2 selected	

6 Interface with GYDA and RS-422 command set

All commands follow the Flashlink protocol and can be used for direct control access to the module. The control system can either be a GYDA-SC or a third-party control system with integrated Flashlink protocol. The module can also be manually controlled with a VT100 compatible terminal program.

The protocol can be found on our web page; <http://www.nevion.com>

HDSOI-CHO-2x1 Command table

Command	Response	Comment
?	See protocol description	The "hello" command
info	Module status information	
reset	OK	Reset latch to main input channel.
set auto	Auto	Set to automatic input channel selection. Automatic input selection enabled.
set main	Main	Set to main input channel. Automatic input selection disabled.
set standby	Standby	Set to standby input channel. Automatic input selection disabled.
timer off	OK	Switch off time delay for input selection automatics
timer on	OK	Switch on time delay for input selection automatics
timer xx	OK	xx is the delay time for the timer. For firmware version 2.0.0 or newer, this is only used for switching from main to standby. (Value stored in EEPROM)
timer_rst xx	OK	xx is the delay time for the secondary timer, used on FW 2.0.0 or newer to reset back to main. (Value stored in EEPROM)
mode los	OK	Input selection automatics based on loss of signal
mode rcl	OK	Input selection automatics based on reclocker in lock
asi on	OK	Set DVB-ASI Reclocker support
asi off	OK	Set SDI 177Mbps Reclocker support
latch on	OK	Latching switch. Must be reset to return from standby to main
latch off	OK	Non-latching switch. Will automatically return to main when input signal is present
rcl on	OK	Reclocker on
rcl off	OK	Reclocker Bypass
eq on	OK	Cable equalizer on
eq off	OK	Cable equalizer Bypass (Los of signal based switch decision will not work on this mode)
main 1	OK	Input 1 configured as main. Input 2 is standby.
main 2	OK	Input 2 configured as main. Input 1 is standby.

General environmental requirements for Nevion equipment

1. The equipment will meet the guaranteed performance specification under the following environmental conditions:
 - Operating room temperature range: 0°C to 40°C
 - Operating relative humidity range: <90% (non-condensing)

2. The equipment will operate without damage under the following environmental conditions:
 - Temperature range: -10°C to 50°C
 - Relative humidity range: <95% (non-condensing)

Product Warranty

The warranty terms and conditions for the product(s) covered by this manual follow the General Sales Conditions by Nevion, which are available on the company web site:

www.nevion.com

Appendix A Materials declaration and recycling information

A.1 Materials declaration

For product sold into China after 1st March 2007, we comply with the “Administrative Measure on the Control of Pollution by Electronic Information Products”. In the first stage of this legislation, content of six hazardous materials has to be declared. The table below shows the required information.

組成名稱 Part Name	Toxic or hazardous substances and elements					
	鉛 Lead (Pb)	汞 Mercury (Hg)	鎘 Cadmium (Cd)	六价铬 Hexavalent Chromium (Cr(VI))	多溴联苯 Polybrominated biphenyls (PBB)	多溴二苯醚 Polybrominated diphenyl ethers (PBDE)
HDSDI-CHO-2x1	0	0	0	0	0	0
O: Indicates that this toxic or hazardous substance contained in all of the homogeneous materials for this part is below the limit requirement in SJ/T11363-2006. X: Indicates that this toxic or hazardous substance contained in at least one of the homogeneous materials used for this part is above the limit requirement in SJ/T11363-2006.						

This is indicated by the product marking:



A.2 Recycling information

Nevion provides assistance to customers and recyclers through our web site <http://www.nevion.com/>. Please contact Nevion’s Customer Support for assistance with recycling if this site does not show the information you require.

Where it is not possible to return the product to Nevion or its agents for recycling, the following general information may be of assistance:

- Before attempting disassembly, ensure the product is completely disconnected from power and signal connections.
- All major parts are marked or labeled to show their material content.
- Depending on the date of manufacture, this product may contain lead in solder.
- Some circuit boards may contain battery-backed memory devices.

EC Declaration of Conformity

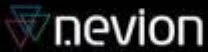

MANUFACTURER	Nevion Europe AS P.O. Box 1020, 3204 Sandefjord, Norway	
AUTHORIZED REPRESENTATIVE (Established within the EEA)	Not applicable	
MODEL NUMBER(S)	HDSDI-CHO-2x1 HDSDI-CHO-2x1-PB	
DESCRIPTION	HD-SDI Change-over 2x1	
DIRECTIVES this equipment complies with	Low voltage (EU Directive 2006/95/EC) EMC (EU Directive 2004/108/EC) RoHS (EU Directive 2002/95/EC) China RoHS ¹ WEEE (EU Directive 2002/96/EC) REACH	
HARMONISED STANDARDS applied in order to verify compliance with Directive(s)	EN 55103-1:1996 EN 55103-2:1996	
TEST REPORTS ISSUED BY	Notified/Competent Body	Report no:
	Nemko	E07380.00
TECHNICAL CONSTRUCTION FILE NO	Not applicable	
YEAR WHICH THE CE-MARK WAS AFFIXED	2008	
TEST AUTHORIZED SIGNATORY MANUFACTURER	AUTHORIZED REPRESENTATIVE (Established within EEA)	Date of Issue
		2008-07-22
		Place of Issue
	Not applicable	Sandefjord, Norway
Name	Thomas Øhrbom	
Position	VP of Quality, Nevion (authorized signature)	

¹ Administration on the Control of Pollution Caused by Electronic Information Products