

User Manual

gard mc

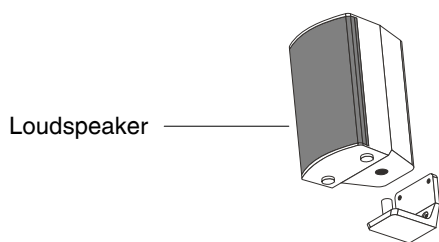

Master Station *gard mc* (surface) with display

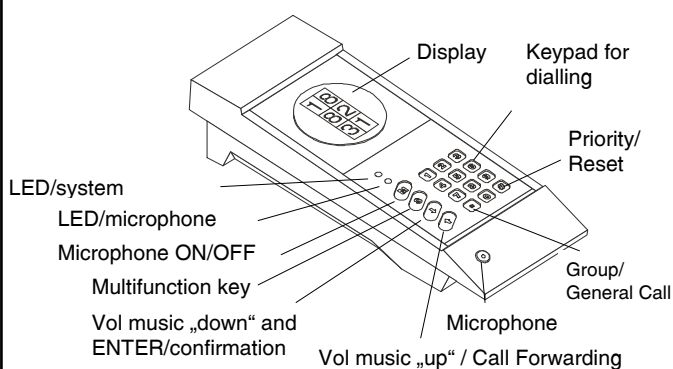

Master Station *gard mc* (recess) with display and directional swan neck microphone

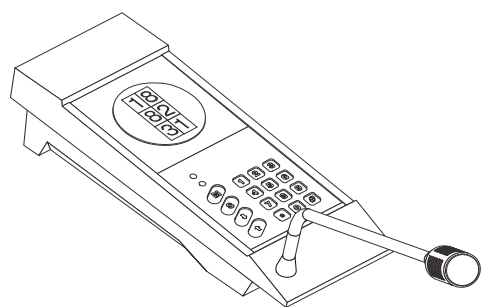

Master Station *gard mc* (recess) with encapsulated stainless steel microphone

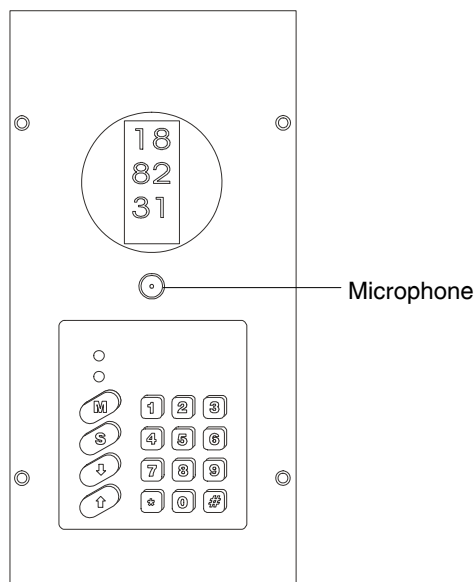

Operating Instructions

● Master / Main Station ●

Read this manual thoroughly before installation and operation of the system.

Content

1. Preliminary steps	3
1.1 Arrangement of the units	3
1.2 Volume Adjustment	3
2. Call and Conversation	3
2.1 Call	3
2.2 Priority	3
2.3 Automatic Call Repetition for 30 sec	3
2.4 Automatic Call Back	4
2.5 Treatment of Call-Backs	4
2.6 Microphone mute (mike OFF)	4
2.7 Privacy („Do not disturb“)	4
2.8 Cancelling a communication	4
3. Special Calls	4
3.1 Group Call	4
3.2 General Call	4
3.3 Answering Group/General Call	4
4. Call Transfer/Forwarding („follow me“)	5
4.1 Call Transfer/Forwarding from <i>own</i> station	5
4.2 Call Forwarding („follow me“)	5
4.3 Call Transfer/Forwarding from <i>another</i> station	5
4.4 Conference	5
5. Audio Programme Distribution	5
5.1 Music	5
6. Master Station	6
6.1. Components Master Station	6
6.2 Master/Master Intercom	6
7. Master/Substation Intercom	6
7.1 Calling a Substation	6
7.2 Treatment of Substation Calls	6
7.3 Selective suppression of Substation Call Signal at master station for individual substations	6
Door Lock Release	7
8. Short-Guidance	7

1. Preliminary Steps

1.1 Arrangement of the units



Clarson Gard MC is a microprocessor-controlled system operating in open duplex technology, i. e. simultaneous bi-directional voice transmission without pushing any buttons and without being influenced by ambient noises.

Best transmission quality is achieved when the following points are observed:

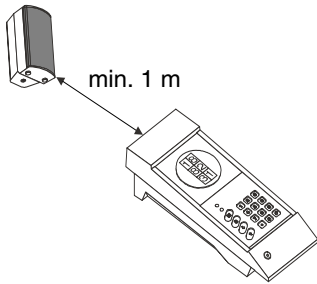

- Minimum distance between table station and loudspeaker = 1 m.

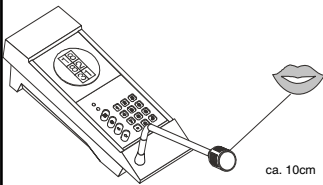

- Stations with *swan-neck microphone* require a speaking distance of approx. 10 cm.

Stations with *omnidirectional microphone* require a speaking distance of 1 m.

1.2 Volume Adjustment

This adjustment should be made when installing a station.

Readjustment might only be required if a station is moved to another place.

The station calls itself when entering code *0↓. Rotate the station by 180°. In the lower third there are 2 holes: under (1) the volume potentiometer is located.

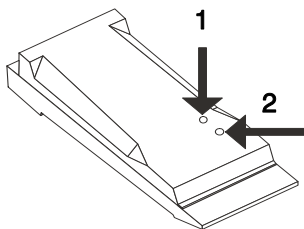

1 = Vol potentiometer

2 = Vol optional handset

Turn the potentiometer with a small screwdriver till the point of feedback is reached. Then turn it slightly back till feedback disappears.

2. Call and Conversation

2.1 Call

Steps carried out at station A:

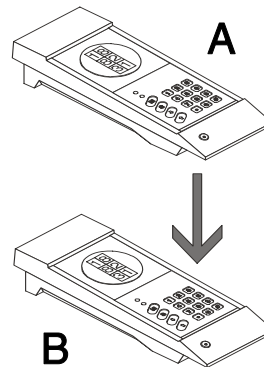

1:
Enter the station number of B via numeric keypad (1). The number of station B flashes in the first display (10).

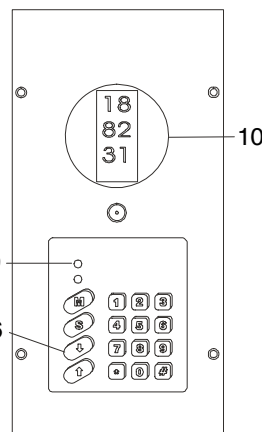

2:
Communication is established by pushing the ENTER key ↓ (6). The station's diode (9) is illuminated if the station is disengaged. If the station is occupied, the diode flashes.

The call number of station A flashes in the first display (10) of station B and the station's diode (9) is illuminated.

2.2 Priority

The priority feature allows to disconnect any existing communication.

Attention! *The priority feature always interrupts a current conversation leaving one of the participants in a waiting loop.*



1: Press the S key (5).
2: Press the ENTER key ↓ (6).

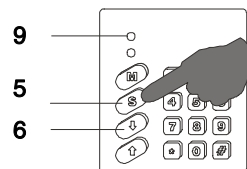

The station's diode (9) is illuminated if the priority call has been successful.

After terminating a priority call, the original communication is restored.

2.3 Automatic Call Repetition for 30 sec.

If station B is engaged, station A may wait 30 sec till station B is free and will then be connected automatically to station B. Otherwise the call is cancelled after 30 sec. This function is deactivated by pressing the # key (2).

2. Call and Conversation

2.4 Automatic Call Back

If you don't want to wait 30 sec if the station is engaged, but make the station call you back:

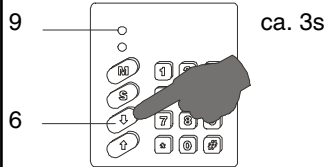

Press the ENTER key ↓(6) until the dialled call number disappears from your display (10) and until the station's diode (9) is out.

2.5 Treatment of Call-Backs

On your display (10) appears another call number whilst you are in conversation. Someone else is trying to reach you. Press the ENTER key ↓(6) after terminating your conversation. You are immediately connected to the 2nd caller.

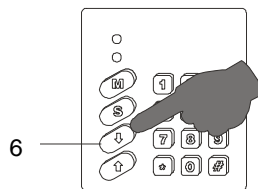

2.6 Microphone mute

Press the M key (4) to switch off the microphone. The microphone diode (8) is illuminated and reminds you of this function.

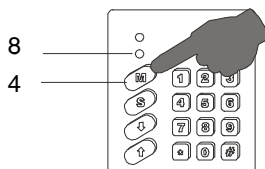

The microphone is reactivated by pressing the M key (4).

2.7 Privacy („Do not disturb“)

Switch off the microphone by pressing the M key (4) for approx. 2 sec till the microphone diode (8) flashes. A signal tone in intervals of approx. 1 min. reminds you of this function. Press the M key (4) to reactivate the microphone. The diode (8) will go out.

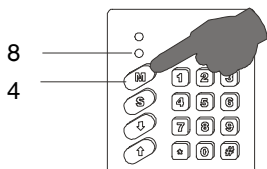

2.8 Cancelling a Communication

Either station A or B cancels a conversation by pressing the # key (2).

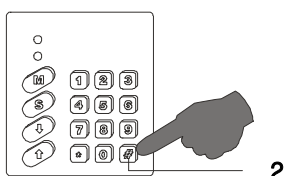

3. Special Calls

3.1 Group Call

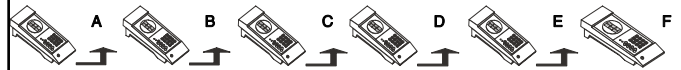

Releasing a group call:

Press subsequently

1. * key (3)
2. Numeric keys (1)
3. ENTER key ↓ (6)

Make your announcement.

If you wait for an answer, i. e. the person paged is expected to reply, don't press the # key immediately thus allowing the person paged to reply (see 3.3). A group call is cancelled by pressing the # key.

Groups have single digit call numbers, f. ex. *1↓.

3.2 General Call



The general call is kind of a group call and is normally released by pressing *1↓.

There are 7 group calls. 8 + 9 are for special functions.

Group and general calls are priority calls. They always interrupt current conversations.



3.3 Answering Group/General Calls

Reply to a group/general call is made by pushing the ENTER key ↓ (6).

The person paged is automatically connected to the station which has released the group call provided that the call meanwhile has not been cancelled.

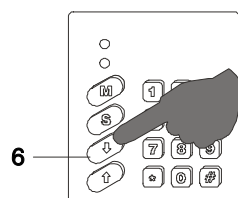

4. Call Transfer/Call Forwarding

4.1 Call Transfer/Call Forwarding („follow me) from own station A

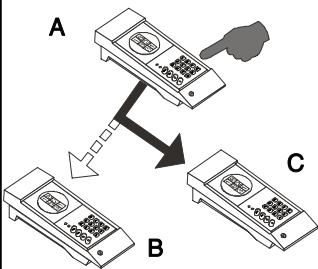

When leaving your room, all incoming calls may be transferred to your temporary location or to any other station.

Proceed as follows:

You are at station A and forward a call to station C:

1. Dial directory number of A
 2. Push the \uparrow key (7)
- Reaction:* Directory number A flashes in the display of station A.
3. Dial directory number of C
 4. Confirm by pushing the ENTER key \downarrow (6).

Reaction: Your own directory number A disappears from the display. A square in the display bottom left and a signal tone in intervals of approx. 1 min. reminds you of the call forwarding. Cancelling the forwarding is made as follows:

1. Enter own directory number A
2. Push \uparrow key (7)
3. Enter own directory number A
4. Push ENTER \downarrow key (6)

4.2 „Follow me“

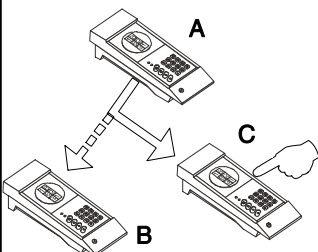

You are at station C and want your calls (A) to be forwarded to station C.

Proceed as follows at C:

1. Dial number of A
2. Push \uparrow (7)
3. Dial number of C
4. Push ENTER key \downarrow (6)

When returning to station A, the square in the display bottom left and a signal tone reminds you of the call forwarding.

Cancelling see 4.1.

4.3 Call Transfer/Call Forwarding from another station

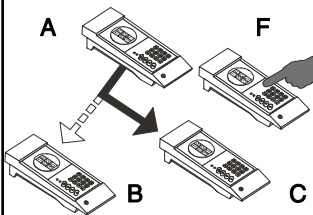

You are at station F and want to forward calls for station A to a third station C:

1. Dial directory number of station A
2. Push \uparrow (7)
3. Dial directory number of station C.
4. Confirm by pushing ENTER key \downarrow (6).

When returning to your own station A, a square in the display bottom left and a signal tone in intervals of approx. 1 min. reminds you of the call forwarding.

Cancelling see 4.1

4.4 Conference

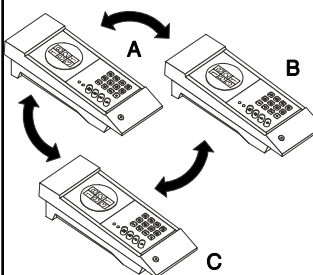

A conference is possible between max. 3 stations.

Station A proceeds as follows:

1. Dial number of stat. B
2. Push ENTER key \downarrow (6)
3. Dial number of stat. C
4. Push ENTER key \downarrow (6)

During the conference the station numbers are flashing in the first and second display (10) of the involved stations and the stations's diodes are illuminated (9).

The conference may be cancelled by any participant pressing the # key

5. Audio Programme Distribution

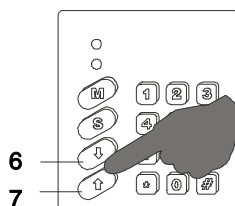

If your station is equipped with this feature, volume is adjusted individually by pressing

\uparrow (7) = „vol up“ and
 \downarrow (6) = „vol down“

These adjustments are made when the station is out of communication.

5. Audio Programme Distribution

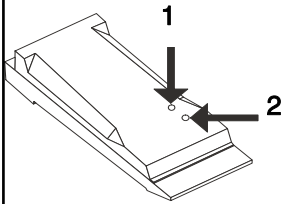

Press ↓↑ keys simultaneously:

→ *music OFF*

Press again ↓↑ keys simultaneously:

→ *music ON*
at medium volume

Basic adjustment (=vol max) is set via potentiometer (1), located on the case bottom.
(2=optional handset)

6. Master Station

6.1 Components Master Station

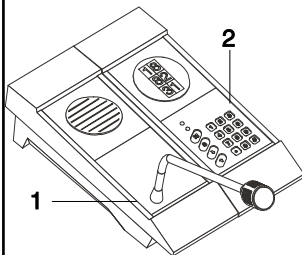

In general master stations consist of two elements:

- **Audio Module** with swan-neck microphone and loudspeaker (1)

- **Operating Module** with display and membrane keypad (2).

Each main station may operate as master station.

6.2 Master/Master Intercom

See pos. 1 - 5

7. Master/Substation Intercom

7.1 Calling a Substation

A master/main station calls a substation as per pos. 1 - 5, however first push the **S** key (5).

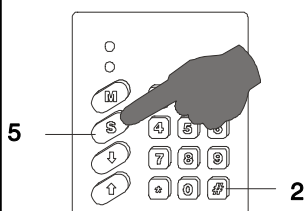

Examples:

Calling substation 1:

S 1 ↓

or substation 13:

S 13 ↓

7.2 Treatment of Substation Calls

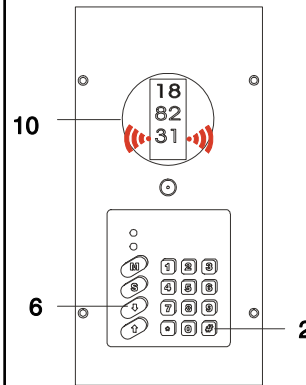

Communication with door stations or similar is established immediately.

However, if cell or bed stations are concerned the station called has to push its speech button to switch on the station's microphone.

Communication is cancelled exclusively by the main/master station by pushing the # key (2).

Substation calls are indicated successively in the display of the master station (10).

In case of more than 3 incoming calls the third display is flashing. Furthermore an audio signal is to be heard if the master station is not in communication.

Calls are treated successively by pushing the ↓ key (6).

To treat a call with preference, proceed as per 7.1.:

7.3 Suppression of call signal at the master station for individual substations

In case of repeated unjustified individual substation calls the call signal at the master station can be suppressed:

Whilst communicating press the following keys:

0 and ↓ ENTER (6).

Cancel conversation by pressing #.

Signal tone is now deactivated, the station's number flashes constantly in the display.

Maximum 4 signal tones can be deactivated.

The call signal is reactivated automatically if a new communication is established with this substation.

Brief Instructions

Volume Control	*0↓ Station calls itself	Call Forwarding/ Call Transfer (from <i>own station</i>)	- Own station no. ↑ Forwarded station no. ↓
Calling a <i>Master / Main Station</i>	- Station number + ↓ (f. ex. 1↓)	<i>cancel</i>	- Own station no. ↑ Own station no. ↓
Calling a <i>Substation</i>	- S + station no. + ↓ (f. ex. S1↓)	Call Forwarding/ Call Transfer (from <i>another station</i>)	- Own station no. ↑ Forwarded station no. ↓
Answering <i>Substation Calls</i>	- ↓ —> Calls are treated successively SXX↓ —> a station is treated with preference	<i>cancel</i>	see above
Cancelling a Call	- #	Call Forwarding („Follow me“)	- Own directory no. ↑ Forwarded station no. ↓
Priority	- S + ↓ (LED on)	<i>cancel</i>	see above
Microphone Mute		Conference (A + B + C)	- A dials station no. B ↓ A dials station no. C ↓
<i>activate</i>	- M —> LED on	<i>cancel</i>	A, B or C push #
<i>cancel</i>	- M —> LED off	Audio Programme Distribution	- Volume Adjustment ↑ = „vol up“ ↓ = „vol down“
Privacy (“Do not disturb”) <i>activate</i>	- Push M for approx. 2 sec —> LED/mike flashes + signal tone	Door Lock Release	S + call no + ↓+ S (example: S1↓S) or ↓+ S
<i>cancel</i>	- Push M —> LED/mike OFF signal tone OFF	Selective suppression of substation calls at the master station	Push 0 and ↓
Group Call	- * X ↓		
General Call	- * 1 ↓		
Automatic Call Repetition for 30 sec	- Automatic switch off after 30 sec or cancel with #		
Automatic Call Back	- Hold down ↓ till directory number disappears from display and LED switches off		
<p>CLARSON APPARATEBAU GMBH POB 11 63 D-78080 Dauchingen / GERMANY</p> <p>☎ +49 (0)7720 99 56 - 0 ☎ +49 (0)7720 99 56 - 22 E-mail: clarson@clarson.de http://www.clarson.de</p>			