

# **SAILBRAIN GPS** **INSTRUCTION** **MANUAL**

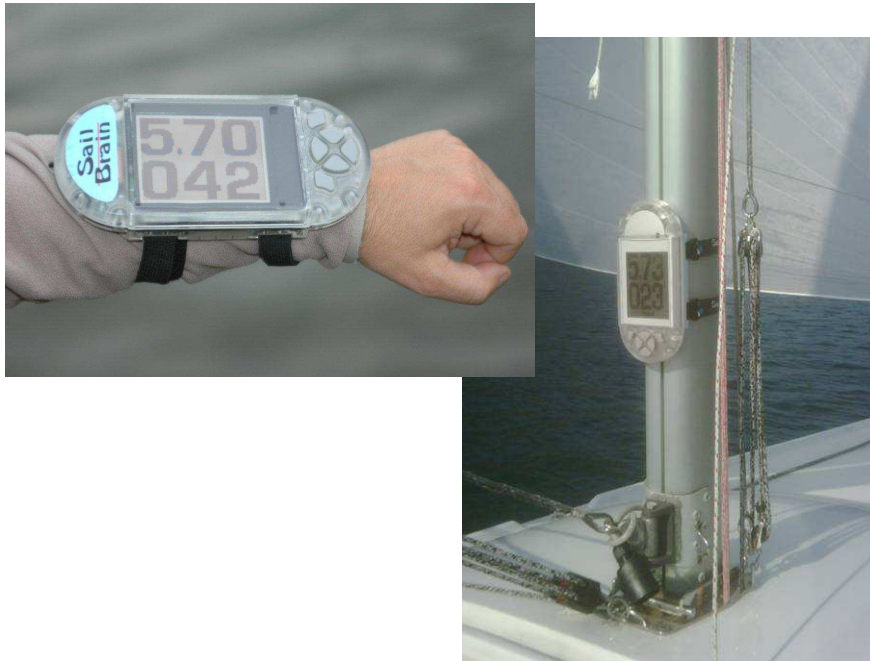

**Versione 1.0 per Firmware 2.6**



**NEW WIND** [ **SAILBRAIN**  
**ELECTRONICS**  
**SAIL INSTRUMENT**  
**WWW.SAILBRAIN.IT** ]

<b>INDEX</b>	
<b>Important informations about privacy</b> .....	3
<b>Important informations on safety</b> .....	3
Start in safe environments .....	3
Road safety .....	3
General precautions .....	3
Equipment and replacement by third parties .....	3
Precautions on repairs .....	3
Indications and precautions on tool and remote control batteries .....	3
Low battery indicator on the tool bar .....	4
Indications on the remote control .....	4
Remote control security .....	4
Remote control code setting .....	5
<b>Introduction to SAILBRAIN</b> .....	6
What is SAILBRAIN .....	6
Technical data .....	6
Operating environment .....	6
Software update .....	6
<b>SailBrain characteristics</b> .....	7
Features SailBrain "COMPASS" model (for dinghies) .....	7
Features SailBrain "GPS" model .....	7
Features SailBrain "PLOT" model .....	7
Features SailBrain " PLOT PLUS REMOTE GPRS " model .....	7
<b>Know your SailBrain functions</b> .....	8
Data displayed with Sailbrain "Compass" model .....	8
Data displayed with Sailbrain "Gps" model .....	8
Data displayed with Sailbrain "Plot" model .....	8
Data displayed with Sailbrain "Plot plus remote Gprs" model ..	9
<b>Startup and shutdown of the device</b> .....	10
Startup of the device .....	10
Signal acquisition .....	10
Shutdown of the device .....	10
<b>Quick start</b> .....	10
Use of external keys of the tool and of remote control .....	10
<b>SailBrain function menù map</b> .....	11
<b>Use of each menu</b> .....	11
<b>Start menu - "SETUP"</b> .....	11
Input .....	11
Function .....	12
View .....	12
Unit .....	14
<b>Start menu - "NAVIGATION"</b> .....	15
<b>Start menu - "RACE"</b> .....	15
Pre race .....	15
Timer .....	16
Waip .....	16
Evo-race .....	17
<b>How to approach for racing usually</b> .....	18
<b>The approach to the race procedure for schemas</b> .....	19
<b>Legend symbols shown for display data on the display</b> .....	20
<b>Declaration of conformity</b> .....	21
<b>Protection of the environment through recycling in the European Community</b> .....	21
<b>Limited manufacturer's warranty</b> .....	21
Warranty period .....	21
What is not covered by the warranty? .....	21
Warranty repair .....	22
Repairs outside the warranty period .....	22
Units outside warranty no longer repairable .....	22
<b>Revision history of instructions</b> .....	23
<b>Appendix to the instructions to download or upgrade SailBrain software on your PC</b> .....	24

## ***IMPORTANT INFORMATIONS ABOUT PRIVACY***

While using functions of this localization device, make sure to comply with all applicable laws and privacy and the rights of others.

When uses the device to detect an updated position, or you have location data for any past period, make sure you comply with the law and not violating privacy and the rights of others.

## ***IMPORTANT INFORMATIONS ON SAFETY***

Read following rules, about any mobile phone use (SAILBRAIN GPRS model includes a GSM module). Failure to comply with these rules may be dangerous or illegal.

SailBrain is a mobil GPS tool, marker of data and performance and should not be used as the primary source of information for navigation.

**Start in safe environments:** do not turn on SAILBRAIN GPRS in environments where is banned the use of the mobile phone. Turn off SAILBRAIN GPRS near medical equipment, power down before embarking on an airplane, shut down in the vicinity of blasting or flammable materials, respect all those limitations that mobile phones are subject.

**Road safety:** do not manipulate the localizer while driving and not to support him in dangerous locations in the event of collision or accident.

### ***General precautions***

Read this informations before you use SAILBRAIN. To reduce the risk of electrical shocks, personal injury, fire, damage to equipment and damages of any kind, carefully review the following precautions.

**Avoid wet areas:** never leave the product for a long time in wet locations, nor near sources of water.

**Avoid areas subject to heat:** place the product away from areas subject to high temperatures. The product must be kept away from sources of heat type radiators, heaters, and all other equipment producing heat.

Do not leave the tool, and remote control inside your car in summer with particularly high outside temperatures.

The heat not only causes damage and spoils the product, but also causes defects on battery. In addition, the heat can cause fires and damages.

**Avoid using the product improperly / unmount it:** NOT disassemble, rebuild or repair this product; otherwise you may cause fire, electrical shocks, and failures. Also, the opening of the device from unauthorized personnel part causes the immediate decay of the guarantee.

**Mounting accessories:** do not use the product on an unstable basis. Avoid installing closely with parties subject to strong vibrations.

**Avoid using products for cleaning very aggressive;** use a concentration at 50 % of simple SOAP and water to clean it.

**Please note that there is not sand or dirty also very fine especially on screen before cleaning;** screen may be damaged and/or scratched.

### ***Equipment and replacement by third parties***

The use of equipment, accessories or batteries supplied by third parties, not produced or authorized by the manufacturer, make nothing product warranty and negatively affect the operational safety of the device itself.

### ***Precautions on repairs***

The device and the battery does not contain repairable parts from the user. Not try never disassemble or repair yourself these parties, otherwise you may cause fire, electric shocks, and failures. Always get in touch with the authorized service centre where they were needed repairs or replacements.

### ***Indications and precautions on tool and remote control batteries***

SAILBRAIN contains within it a 3.6V. battery.

- Do not disassemble or modify the battery
- Stop using your device if you detect abnormal temperatures, odours, loss of color and deformation, or if you see abnormal conditions during use or storage.

- Not to throw anything on fire and dispose according to local regulations.
- The battery to fire or high temperature exposure could lead to the explosion of the battery.
- Do not try to replace with equivalent batteries and do not use the above battery for different purposes.
- Do not attempt to charge the battery outside of the device.

Exposure to temperatures below to the -20 ° C degrees or above the +50°C can irreparably damage the battery.

Leave the battery (or apparatus) in hot or cold environments (such as for example a closed car in summer or winter) will reduce the capacity and the lifetime of the battery.

A device with a hot or cold battery may temporarily not work regardless of the status of the battery.

The performance of the battery is still greatly reduced at temperatures below to the 0 ° C.

All the data in this manual refers to a functional battery around 20° C and in standard environmental conditions.

The duration of the battery of the instrument differs depending on the use or less of the backlight:

- At least 18 hours without backlight for night view
- At least 10 hours with backlight for night view

You do not have to remove the internal battery even if you do not use the tool for a prolonged time period.

It's not necessary to remove any battery from the tool for charging; you can recharge battery simply by attaching it, to a power outlet, the given charger included and using the appropriate connection located at the rear of the tool. The total elapsed time previewed to charge the battery, if the battery was completely discharged, it is approximately 8 hours. CAUTION: make sure that the connector screw useful for charging is entering into its housing with one

click and screwed without forcing too: a led lit informs you that the tool is regularly on charge.

#### ***Low battery indicator on the tool bar***

When you'll see, in the menu page on the screen in low/left angle of the instrument, the symbol indicating the charged low battery, you have approximately 2 hours of battery available.

#### ***Indications on the remote control***

The remote control battery life is approximately 2 years and it is replaceable.

- If your remote control is lost or damaged, it can easily be replaced. Contact us for details of the case.
- Remote controller-similar keys are located on the outside of the tool; you can always set your SailBrain on your favorite functions using the buttons on the tool.

#### ***Remote control security:***

- Rain and spray: No additional protection for your remote control is required.
- Possible immersion: Protect your remote ensuring of a watertight protection.
- Tip: on keel boats not particularly wetted there is no problem; on dinghies where there is a possibility that you have swim with the remote control or anyway on boats particularly "wetted", used a watertight security.

**Remote control code setting:**

In case your remote is lost and you must replace it, it is necessary to set it up again on the instrument to be connected to it.

This operation is necessary register within 30 seconds after turning on the power of the instrument.

- Enter in the "View" menu below shown;
- Enter in the "Radio Remote" submenu and set it on **ACQ**;
- Press any key on the remote control pressed until you hear an acquisition signal;

Try now that the remote control is connected to the instrument.

## **INTRODUCTION TO SAILBRAIN**

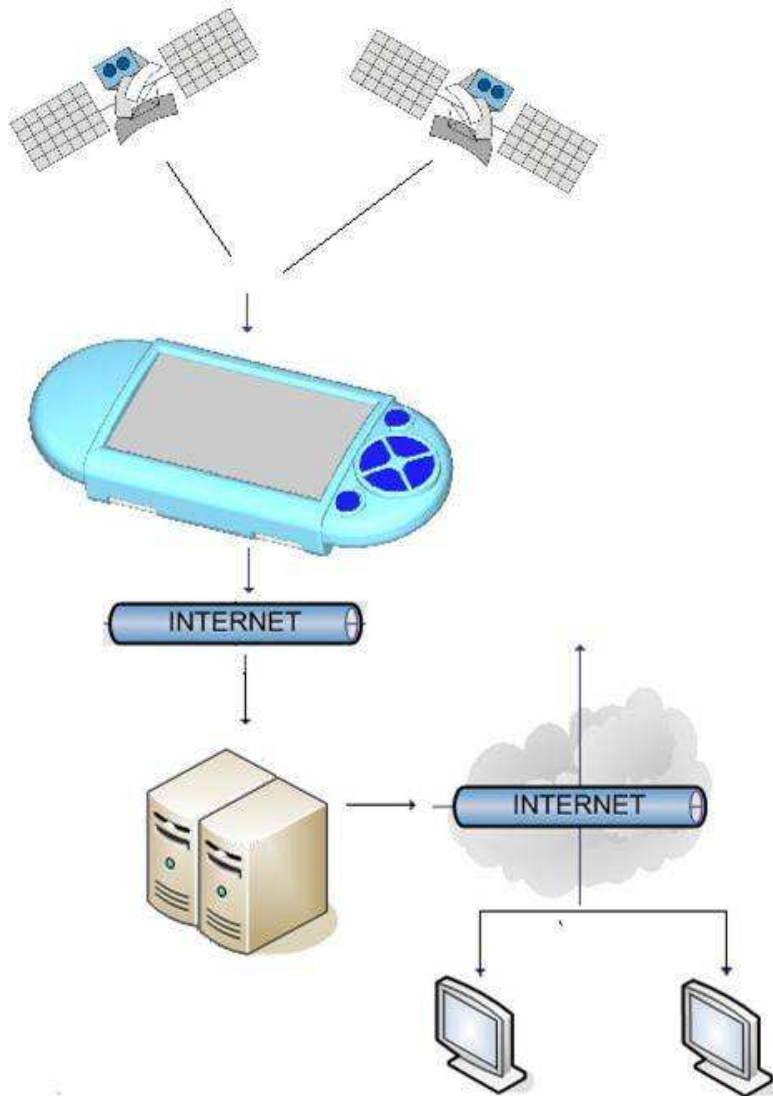

## **What is SAILBRAIN**

The device consists of a GPS Locator with graphic display specifically designed for use in training or regattas but also useful on cruise vessels. The easy installation makes it suitable to any vessel.

Only GPRS REMOTE PLUSE PLOT model has a gprs module and a SIM useful to communicate with the portal SAILBRAIN and then distribute information.

### **Technical data**

Dimensions of the device: (L x H x W): 192,6 x 89 x 28/31 mm.

Weight: 250 g

Screen dimensions:

- Color screen 16:9: (L x H x D): 95,0 x 55,0 x 110,0 mm.
- Black & white screen 4:3: (L x H x D): 80,0 x 62,0 x 100,0 mm.

### **Operating environment**

Temperature: -25 ÷ +70 °C

Humidity: Less than 85%

### **Software update**

Every time that are added to the SailBrain new features or software upgrades, you can update your device using the software for the PC SailBrain update to update the firmware.

## **SAILBRAIN CHARACTERISTICS**

### **Features SailBrain "COMPASS" model (for dinghies):**

- Magnetic compass;
- Only digit view;

### **Features SailBrain "GPS" model:**

- Sequential menu user-friendly for the selection of each function;
- Modular design with the possibility of applying both to the forearm that to the mast;
- Very large screen;
- Viewing of very large numbers and choice of emissions data in multiple formats (from 1 to 6 data exposed);
- Possibility of waypoints setting;
- All available functions necessary for navigation and the race;
- Registration data up to 50,000 points;
- USB port to transfer data to your PC using software SailBrain update;
- Battery duration very large compared to other similar instruments;
- Firmware easily upgradeable;
- GPS accompanied by accelerometers and miscellaneous filters capable of a speed of 5 Hz.;
- Only digit view;



### **Features SailBrain "PLOT" model:**

In addition to above in the "GPS" model, the "PLOT" version will have the following additional features:

- Remote control to change functions without having to go to the mast!!!!!!
- GPS accompanied by accelerometers and miscellaneous filters capable of a speed of 5 Hz.;
- GRAPHIC VIEW ON THE DISPLAY OF THE OWN BOAT ON THE RACE COURSE;
- GRAPHIC VIEW ON THE DISPLAY OF THE LAY LINES JUST ON THE PRE-RACE COURSE AND DURING THE RACE;

- GRAPHIC VIEW ON THE DISPLAY OF THE LAY LINES BOTH DURING UP-WIND LEG AND DOWNWIND LEG ACCORDING TO THE TARGET PREVIOUSLY SET;
- VIEWING OF THE DISTANCE, EXPRESSED IN TIME, FROM THE LAY LINES BOTH DURING UP-WIND LEG AND DOWNWIND LEG ACCORDING TO THE TARGET PREVIOUSLY SET;
- GRAPHIC VIEW ON THE DISPLAY, DURING THE RACE, OF YOUR TRACKS TRAVELLED DURING THE PREVIOUS LEG;
- Self adapting tack angle and speed target;
- Self detecting marks;
- "Training" functions to optimize manoeuvres and optimization of the boat;
- Possibility of reviewing immediately on the unit, with graphic view, the just ended race or download it with its data on your pc;
- Very high tactical capacity;
- Graphic view related to the VMG.

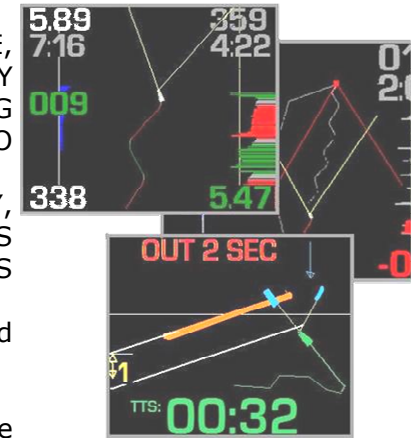

### **Features SailBrain " PLOT PLUS REMOTE GPRS " model:**

In addition to above in the "PLOT" model, the "PLOT PLUS REMOTE GPRS" model will have the following additional features:

- Gprs Modem for sharing infos.

## KNOW YOUR SAILBRAIN FUNCTIONS

### SAILBRAIN MODEL "COMPASS" FOR DINGHIES (2 data viewed)

#### DATA DISPLAYED:

- Compass degree;
- Inclinometer;

### SAILBRAIN MODEL "GPS" (data viewed from 1 to 6 digits according to your choice previously set in "View" menu): DATA DISPLAYED:

#### **DURING THE START:**

- Spd: speed;
- Head: Your compass direction expressed in degrees;
- RDTL: distance to the starting line according to your course of the moment;
- PDTL: distance to the starting line taken perpendicularly to the starting line;
- TTS: time to the starting line with the speed of the moment;
- TIM: Countdown to the start.

TTS: -3  
Rdtl: 94.2  
Tim: 0:27

Rdtl: 94.2  
Tim: 0:27

033°

Spd: 5.18  
Head: 035°  
TVmg: 5.07  
EvoRace1/4

#### **AFTER THE START:**

- Spd: speed;
- Head: compass direction expressed in degrees;
- Wind: wind direction expressed in degrees;
- Tvmg: target of your vmg in that moment compared to the previously set functions;
- Coordinates of latitude and longitude of that moment;
- View of the true tack angle, expressed in degrees, every time you make it;

### SAILBRAIN MODEL "PLOT" (data viewed from 1 to 8 digits according to your choice

### previously set in "View" menu): DATA DISPLAYED:

In addition to above in the "GPS" model, the "PLOT" model will have the following additional features:

#### **DURING THE START:**

- All the data up shown but with the help of the GRAPHIC VIEW;
- Detection, expressed in degrees, of the starting line from the right side to left or contrary, depending on what previously set. The data of this function will appear after you have started the countdown;
- GRAPHIC VIEW of the start area with included lay lines for the mark and for that race committee and of your boat related to the start area;

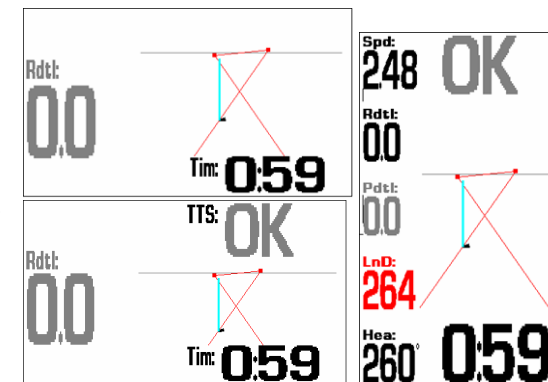

#### **AFTER THE START:**

- All the data up shown but with the help of the GRAPHIC VIEW that on your choice will be displayed on all the race field (Plot All) or maximized on your boat (Plot Near) or to Mark (Plot to Mark);
- Distance to lay lines expressed both in time and through the GRAPHIC VIEW.

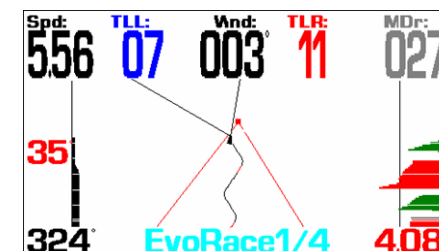
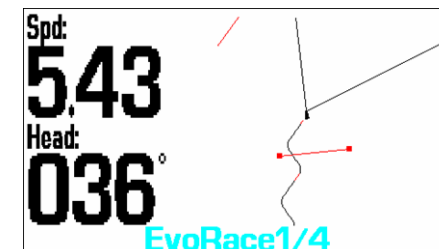



**SAILBRAIN MODEL "PLOT PLUS REMOTE GPRS" (data viewed from 1 to 8 digits according to your choice previously set in "View" menù) DATA DISPLAYED:**

In addition to above in the "PLOT" model, the "PLOT PLUS REMOTE GPRS" model will have the following additional features:

- Presence of a Gprs Modem for sharing infos.

## STARTUP AND SHUTDOWN OF THE DEVICE

### Startup of the device

To activate SAILBRAIN you must press on the button beside shown for about 1 second; after 2/3 seconds the instrument will turn on.

ATTENTION: the same button can be used, on Plot model, also for Plot view mode pressing \_\_\_\_\_ repeatedly depending on the desired zoom level.



### Signal acquisition:

- When SailBrain is enabled, the device requires some minutes in the first startup and less in the following uses (usually 1 or less) for the acquisition of necessary gps information.
- Just switch on, your SailBrain immediately begins to work and will not acquire a signal up to will not disappear the written "INVALID GPS FIX".
- Only when disappears the written shown above, the tool will begin to issue reliable data.
- The necessary signal will be captured only if the tool is used in a outdoors place.
- If you want to see how many satellites are available for the acquisition of the necessary GPS information, disabled the function Plot by briefly pressing the same key is used to power up until appears "Plot off" and press the "Esc" key (see below) until you see the graduated scale that indicates the number of available satellites. Only the latter will be necessary only in GPS model. For a good signal reception you must see at least 6 or 7 bars filled in scale.

### Shutdown of the device

To disable SAILBRAIN you must press the same key is used to power up until the display will turn off (about 3 seconds).

## QUICK START

**Using external keyboard on the instrument and of the remote control to change your SailBrain functions:**

Navigate to the menu of the individual functions by pressing the keys indicated, highlighted both on the tool and on the supplied remote control.

- When you'll see the function that you want, simply wait for 5 seconds (depending on entered settings in "View" menu) for the function you want to appear on the screen, or press ECS key.
- MOVING BETWEEN THE FUNCTIONS: If you want to use and highlight different functions you'll only need to move with the 4 buttons beside indicated to move from one menu or function to another ones.
- To exit from a selected menu, and/or to select a different one, you can or press either any of the buttons above indicated, or press the "ESC" key positioned in the low part of the tool or wait the 5 seconds above shown.
- The key "ESC" is usefull also to see the different data according to your previous choice setted in the tool.



Remote control works exactly the same as indicated for keys located on the tool.

## SAIL BRAIN FUNCTION MENU MAP

- When you startup your SailBrain will appear the main menu and, according to the plan shown below, will appear the page with functions Setup - Race - Navigation.

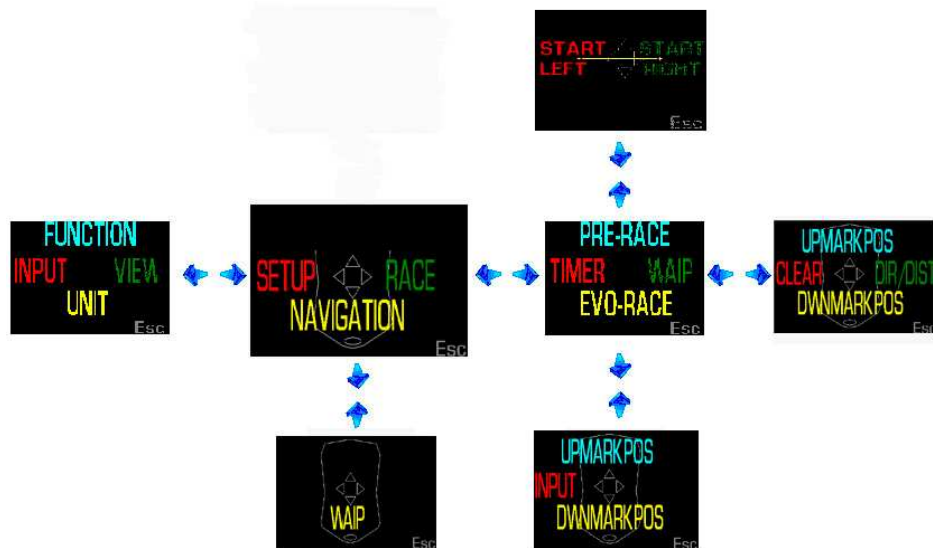

- As previously said, and according to the the plan up shown, the general menu of the instrument is strictly sequential; to exit from a selected menu, and/or to select a different one, you can or press either any of the buttons above indicated, or press the "ESC" key positioned in the low part of the tool. or the tool will automatically exit after 5 seconds of not working.

## USE OF EACH MENU'

### START MENU' – "SETUP":

Before to use the tool during navigation, we recommend that you enter into this menu because it allows setting of important functions and data of your boat to use the tool properly.

In this menu there are some submenu that enable the following settings:

- INPUT:**

The functions mentioned in this menu are displayed automatically in "Race Mode" but you can and should set them manually in this drop-down menu where you can select 9 settings:

- Setup mode:** You can i.e. set tool depending on whether you are in pre-race ("PRE"), race ("RACE"), navigation ("NAVI") or training ("TRAIN"). This function will be automatically setted depending on the menu that you will go on later;
- Wind mode:** This function ensure that the wind direction, in Plot view and during training, always comes from the top of the screen;
- Hand Mode:** If you want to start collecting useful data for training and you have just turned on the tool, you can communicate to the instrument that you're Windward starboard, selecting "Starboard" or Windward port, selecting "Port";
- Wind Direction:** wind direction in degrees detected by the tool during some tacks before start and during the race. You can see this function on the screen also without entering in this menu;
- Base Wind Direction:** actual wind direction in degrees normally corresponding to the direction of upwind mark;

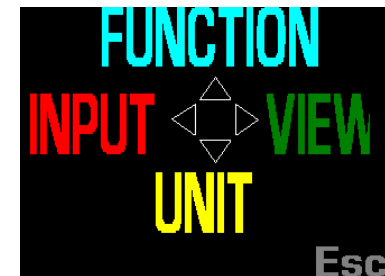

SetupMode:	Navi
WindMode:	Unkn
HandMode:	Unkn
Wind Direction:	359
BaseWind Direction:	0
UpWind Targ Angle:	35
UpWind Targ Speed:	5.00
DownWind Targ Angle:	165
DownWind Targ Speed:	5.00

**ATTENTION:** for proper emission of the wind direction data, it is good practice to make a few tacks (usually 3 or 4) before start;

later, before the beginning of the starting procedures, do a check to the wind and you see the wind direction on the compass. Normally you will find already in "Wind direction" the correct wind direction: if you detect some discrepancy in that regard, it is a good idea to force the wind direction detected in the previous check by entering it in both "Wind direction" that in "Base wind direction".

- **UpWind Targ Angle:** it's your target of the true upwind angle related to wind direction (useful for the precision timing to the starting line);
- **UpWind Targ Speed:** : it's your target of the true upwind speed (useful for the precision timing to the the starting line);
- **DwWnd Targ Angle:** : it's your target of the true downwind angle related to wind direction (useful for the precision timing to the the starting line);
- **DwWnd Targ Speed:** it's your target of the true downwind speed (useful for the precision timing to the the starting line);

• **FUNCTION:**

This is a drop-down menu and allows various settings related the view of the data and the precision of them.

- **Mark Detect ON / OFF**  
This menu allows you to, or less if set to ON or OFF, the release of the marks of the race. In GPS model this function will be set on OFF by default.
- **WindSh Detct ON / OFF**  
This menu allows you to, or less if set to ON or OFF, the wind shift detection.

• **VIEW:**

This menu, also as drop-down menu, allows you to set the tool according to the use of the moment. Contains several settings all important for how you want to see the data on the display once you leave moorings.

YOU WILL HAVE TO CHOOSE THESE SETTINGS ONLY ON FIRST USE AND IF YOU WISH TO CHANGE SCREEN WHILE SAILING (IF YOU SET MORE THAN ONE POSSIBILITY) YOU CAN SELECT THEM BY SIMPLY CLICKING ON THE "ESC" KEY TO MOVE FROM ONE SCREEN TO ANOTHER:

- Screen orientation: sets the possibility of displaying data on the screen vertically or horizontally;
- Background color (only color display): sets the ability to view the background black or white;
- Font: sets the ability of normal character ("norm") or bold ("bold");
- Nightlight: allows the lighting screen for viewing nigh
- Contrast (only black and white display): sets the amount of contrast which is displayed on the screen;
- Beep Key: allows to set the length of the sound that you hear when you press a key on the keyboard;
- User Option: possibility of setting the instrument very detailed ("Full") or simpler but less detailed ("Basic" recommended);
- Radio remote: If set to on enables communication between the instrument and the remote control;
- **Pre race Digi view:** This function allows you to set the individual screens of your interest, by clicking ON to them, with respect to the issuance ONLY of digital data during starting procedure. Obviously less are the required data and more the numbers appear larger on the screen.

- **Spd – Head – RDtl – Pdtl – WDir – TTS – Time (Speed – Heading – Distance from starting line along your course – Perpendicular distance from starting line – Wind direction – Time to the starting line – Timer)**

<b>Spd:</b>	<b>5.87</b>
<b>Rdtl:</b>	<b>94.2</b>
<b>Pdtl:</b>	<b>66.5</b>
<b>LnD:</b> 264	<b>TTS:</b> <b>-3</b>
<b>Wnd:</b> 000'	<b>Tim:</b> <b>0:27</b>
<b>Hea:</b> 039'	

- Spd – RDtl – Pdtl – TTS – Time (Speed – Distance from starting line along your course – Perpendicular distance from starting line – Time to the starting line – Timer)

Spd: 5.87  
Rdtl: 94.2  
Pdtl: 66.5  
TTS: -3  
Tim: 0:27

- Spd – SDtl – TTS – Time (Speed – Selected distance from starting line – Time to the starting line – Timer)

Spd: 5.87 TTS: -3  
Rdtl: 94.2 Tim: 0:27

- Spd – Head – TTS – Time (Speed – Heading – Time to the starting line – Timer)

Spd: 5.87 TTS: -3  
Hea: 039 Tim: 0:27

- SDtl – TTS – Time (Selected distance from starting line – Time to the starting line – Timer)

TTS: -3  
Rdtl: 94.2  
Tim: 0:27

- Spd – Time (Speed – Timer)

Spd: 5.87  
Tim: 0:27

- SDtl – Time (Selected distance from starting line – Timer)

SDtl: 94.2  
Tim: 0:27

- TTS – Time (Time to the starting line – Timer)

TTS: -3  
Tim: 0:27

- **Evo race Digi view:** This function allows you to set the individual screens of your interest, by clicking ON to them, with respect to the issuance ONLY of digital data after starting procedure. Less are the required data and more the numbers appear larger on the screen.

- Spd – Head – WDir - TVmg (Speed – Heading – Wind direction - True Vmg)

- Spd – Head - WDir (Speed – Heading – Wind direction)

- Spd – Head - TVmg (Speed – Heading – True Vmg)

Spd: **5.18**  
 Head: **035°**  
 TVmg: **5.07**  
 EvoRace1/4

- Spd – Head (Speed – Heading)

**5.18**  
**354°**  
 EvoRace1/4

- Spd (Speed)

**4.75**

- Head (Heading)

**033°**

- Date – Coor - Spd – Head - Sat (Date – Coordinate - Speed – Heading – Visible satellites)

Date: **22/10/09**  
 Time: **010104**  
 Lat: **N455548"**  
 Lon: **E091718"**  
 Spd: **5.62**  
 Head: **324°**  
 EvoRace1/4

- SelectDistTo Line: sets the ability to display the distance from the starting line along your course of the time ("Real") or perpendicular to the starting line ("Perp");
- Start Ang: it allows, after placing extremes of the starting line, to view compass degrees of the starting line from right to left ("RightLeft") or from left to right ("LeftRight"). The data of this function will appear after you have started the countdown;
- Autoexit Menu: sets the time in seconds in which the instrument automatically exits from the menu displayed without having to touch any buttons on the instrument;
- DemoMode: it's usefull if you want to view a demo to view data on the tool ("On" or "Off" setting possibilities);
- DemoPause: it's usefull if you want to pause demo function ("On" or "Off" setting possibilities);
- DemoSpeed: it's usefull to set acceleration times of demo function view (possibility of setting a number from 1 to 10);
- DemoPart: ability to set the demo function just for the start ("Start") or for all the race ("All");

- **UNIT:**

Into this menu, also as drop-down menu, you can set the selected unit of measure IT WILL BE NECESSARY TO CHOOSE THESE SETTINGS ONLY ON FIRST USE::

- SpeedUnits: setting of speed in knots ("Knots"), meters per second settings ("Mt/Sec"), or in kilometers per hour ("Km/Hr");
- Distance to Start: setting of the

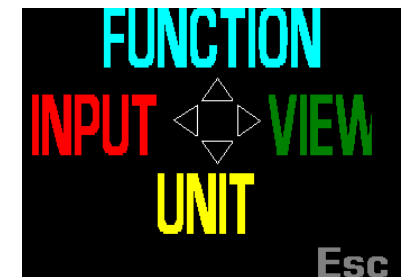

distance from starting line viewable in meters ("Mt"), length ("Lenght"), miles ("Miles"), or in Kilometers ("Kmeter");

- o Compass offset: it's a kind of magnetic variation;
- o Head Average sec: constitutes a kind of damping for the transmission of compass direction: it's usually a good parameter when set to 5 or 6;
- o Speed Average sec: constitutes a kind of damping for the transmission of boat speed: it's usually a good parameter when set to 3 or 4;
- o Time Zone Offset Hour: sets the current time zone;
- o Boat Dim unit: setting the length of the boat in centimeters ("cm"), meters ("mt") or feet (feet ");
- o Boat Len: setting of the boat length;
- o J Len: setting of the "J" length (measure from the bow to the front of the mast) if the instrument is held to the mast or the distance from the bow to the position of the instrument or of the crew member which takes the tool to the forearm, so that the tool can calculate this distance above all to correctly display the distance and the time from the starting line;

Speed Unit:	Knots
Dist ToMark Unit:	Mt
Dist ToStartLine Unit:	Mt
CompassOffset:	0
HeadAverageSec:	5
SpeedAverageSec:	3
TimeZoneOffsetHour:	1
Boat Dim Unit:	Cm
Boat Len :	750
1 / 12 ▾ Esc	

### **START MENU' – "NAVIGATION":**

This menu represents a kind of shortcut that can anticipate the times to go to the "Race" menu, as follows, and specifically to the function "Waip" where you can set the race marks.

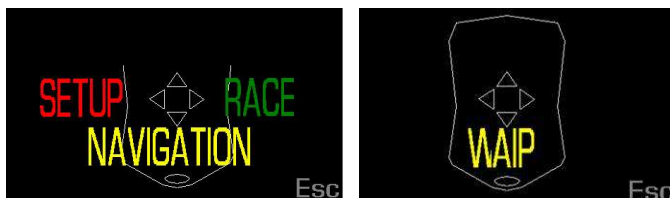

### **START MENU' – "RACE":**

This menu introduces us to all the informations we wish to receive during a race; SailBrain was designed so that the exposed functions of the menu have a logical and sequential sense according to the usual procedures to make a race.



Therefore in this menu will appear the following functions:

- **PRE-RACE:**

This menu allows you to set the extremes of the starting line. With SailBrain you can easily do it because when you approach, at constant speed and always coming from down of the starting line, to the left extreme of the starting line, you have just click on the "Start Left" function and when you approach, always at constant speed and always coming from down of the starting line, to the right extreme of the starting line, you have just click on the "Start Right" function.



SailBrain presents a big particularity compared to competing tools: if during the starting procedure one of the two extremes of the starting line will move, it will be sufficient resets only the end that has changed its position and NOT THE ALL STARTING LINE.

**ATTENTION: DETECTION OF THE ENDS OF THE STARTING LINE MUST BE SELECTED WHEN IT IS THE INSTRUMENT TO BE ALONGSIDE THE MARK AND THE RACE COMMITTEE AND NOT WHEN THE BOW IS ALONGSIDE THEM.**

Only for this function and timer function (shown below) you can exit from this menu only selecting the desired function (Start left or Start right) or by pressing Esc (there is no automatic exit from menu after 5 seconds of not using).

- **TIMER:**

Setting the countdown to the start with the choice of 5, 4, 3, or 1 minute; also in the case of



re-start, the previously set inputs remain in memory.

Only for this function and Pre race function (up shown) you can exit from this menu only selecting the desired function (5, 4, 3, 1) or by pressing Esc (there is no automatic exit from menu after 5 seconds of not using).

- **WAIP:**

Into this menù it's possibile to set some data that will be a lot usefull during the race:

- Upmark Pos: it allows, clicking on, entered the upwind mark while passes alongside, for example at the end of the first upwind leg, so as to have more correct data during the second upwind leg of the same race. **Please note that SailBrain is already able to detect automatically the marks, so this function should not be required ;**
- Dwnmark Pos: it allows, clicking on, entered the downwind mark while passes alongside, for example at the end of the first downwind leg, so as to have more correct data during the second downwind leg of the same race. **Please note that SailBrain is already able to detect automatically the marks so this function should not be required;**



- Dir/Dist: this menu, also as drop-down menu, is very important because allows, before the race start, to set the following information:



- Dist To Mark Unit: allows you to set the distances to the mark in metres ("mt"), mile ("miles") or kilometres ("kmeter");
- Start → UpMark Dir: setting of the upwind mark direction from the starting line expressed in degrees;
- Start → UpMarkDist: setting of the upwind mark distance from the starting line;
- Up → DownMark Dir: setting of the downwind mark direction from the upwind mark expressed in degrees. By default, once entered the direction of upwind mark, SailBrain enters the direction for downwind mark by adding or subtracting 180°;
- Up → DownMarkDist: setting of the downwind mark distance from the upwind mark. By default, once entered the distance upwind, SailBrain enters the same distance to the downwind mark: make attention to correct this data if necessary;
- Usage: This is very important function because it allows, when "At Next Start" is set, to set all the race course as shown above for the first race of the day or for those races to follow, if the race course is not changed, if set on "At All" is set, or, if set on "Now", allows to enter directions and distances of the mark at starting procedure already begun, **FOR EXAMPLE WHEN SIGNALLED A CHANGE OF COURSE.**
- Clear: This function allows you to "clean" the race field from marks possibly placed incorrectly;



- **Evo-Race:**

This submenu, practically, reflects some previously listed functions and represents a kind of shortcut to return to previous menu shortening times to use.

In fact this menu, by selecting the following functions, allows for:



- Upmark Pos: it allows, clicking on, entered the upwind mark while passes alongside, ( RECOMMENDED IN CASE OF AT THE UPWIND MARK, THE OFFSET MARK IS NOT WELL POSITIONED AND CONSTITUTES A KIND OF CONTINUATION OF UPWIND COURSE). **Please note that if the offset mark is well positioned, SailBrain is already able to detect automatically the upwind mark so this function should not be required;**
- Dwnmark Pos: it allows, clicking on, entered the downwind mark while passes alongside. **Please note that SailBrain is already able to detect automatically the marks so this function should not be required;**
- Input: allows to return to one of the first settings without having to go to "Setup" menu.

## **HOW TO APPROACH FOR RACING USUALLY:**

These are the procedures usually used to start for a race:

1. Startup your SailBrain;
2. Set the length and the J of your boat and how you want to display all the units of all measurement data refer to (to do only the first time and before to go for the race): SETUP → UNIT;
3. Set the screens of your liking during both the departure and after the same (to do usually only the first time and before to go for the race): SETUP → VIEW;
4. Set if you want that SailBrain will indicate the starting line compass degrees from the right extreme to left or contrary as soon as countdown will start (to do only the first time and before to go for the race): SETUP → VIEW → STARTLINEANG;
5. Before to start make 2 or 4 close tacks and with the angle to the wind which is the most similar as possible. SailBrain will autodetect the wind direction at that time. If you want a check you can set yourself the wind direction by pointing out it perfectly in the same direction of the wind and watching the degrees of your compass direction: in this last case not made detection of wind direction at a speed too low, and if you made both the 2 close tacks and check properly you can see that in SETUP → INPUT → WIND DIR direction is already set and correct. **TIP: If you find discrepancies between the wind direction detected by the tool during the tacks or if you don't have enough time to do them, set the direction of the wind of your check in SETUP → INPUT both in WIND DIR that BASE WIND DIR;**
6. Set into SETUP → INPUT targets of your boat for a correct display of the times to the starting line and layline.
7. Set SETUP → RACE → WAIP → DIR/DIST distance and direction of marks; **IMPORTANT: to correctly display data after departure it is important to set the direction and distance of marks before you start the timer;**
8. Place the right end of the starting line: RACE → PRE-RACE → START RIGHT as previously shown;
9. Place the left end of the starting line: RACE → PRE-RACE → START LEFT as previously shown;
10. If you want, you can make provisionally start the countdown: RACE → TIMER and SailBrain will give you the compass direction of the

starting line from right to left end according to as you have previously set.

11. At this point you are ready to start for your race; wait for the starting procedure and make your choices. Sail Brain will help you with its graphical view that, depending on whether the line perfectly horizontal or not, will indicate to you from which part of the starting line it's better to start. In this mode you can choose the emission partial data (11.a) or the display of all data that SailBrain offers (11.b) according to your previous choice;
12. Immediately after the starting signal SailBrain will automatically be in a mode (Race mode) that will expose data you deem appropriate in accordance with the previously chosen settings. If you want to change the following settings you just press the "ESC" button to modify the desired settings;

## THE APPROACH TO THE RACE PROCEDURE FOR SCHEMAS:

Summarizing the procedure in the respective points for schemas is the following:

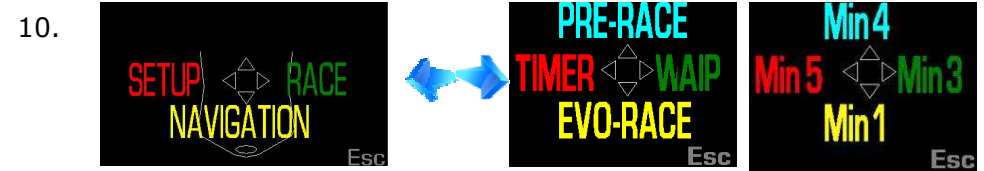
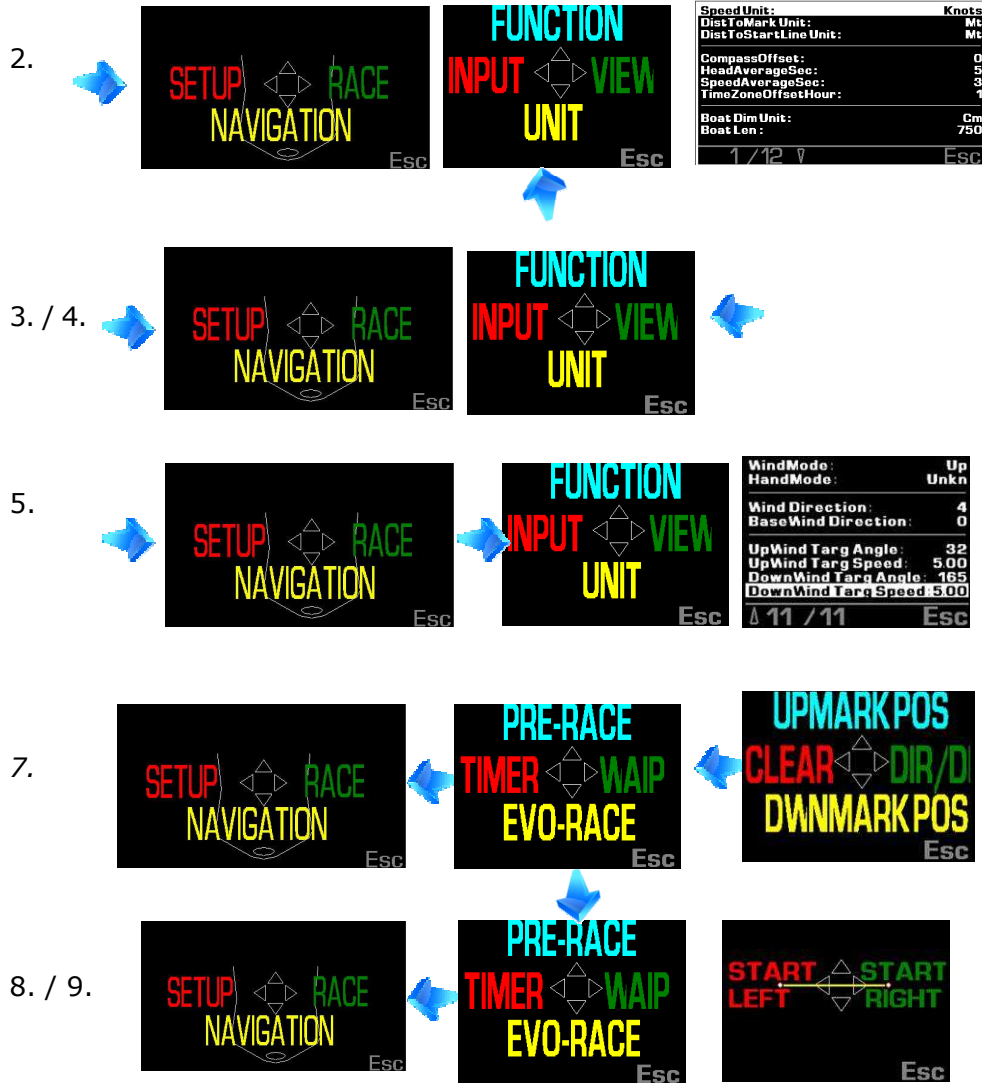

11.a dati parziali

T	-3
S	
T	0:27
m	
Spd:	587
Rdtl:	942
Pdtl:	665
TTS:	-3
Tim:	0:27

11.b tutti dati

12. a dati parziali

4.75
------

12. b tutti dati

Spd:	5.18
Head:	035°
TVmg:	5.07
EvoRace1/4	

**LEGENDA SIGLE INDICATE PER VISUALIZZAZIONE DATI  
SUL DISPLAY IN ORDINE ALFABETICO:**

<b>Date:</b>	Date;
<b>Head:</b>	Heading;
<b>Lat:</b>	Latitude;
<b>Lon:</b>	Longitude;
<b>LnD:</b>	Line direction: Compass direction of starting line (from right to left or contrary according to previously set);
<b>MDr:</b>	Mark direction;
<b>PDTL:</b>	Perpendicular distance to Line;
<b>RDTL:</b>	Real distance to Line (along your course);
<b>SDTL:</b>	Selectioned distance to line;
<b>Spd:</b>	Speed;
<b>Time:</b>	Time or Timer – Current Time or countdown;
<b>TVmg:</b>	True Vmg;
<b>TTS:</b>	Time to Start;
<b>Wnd:</b>	Wind direction;

## **DECLARATION OF CONFORMITY**

The manufacturer shall declare that this equipment is in compliance with the essential requirements and other relevant provisions of Directive 1999/5/EC.

This product may contain articles, technology or software subject to export laws and regulations of the United States and other countries.

## **PROTECTION OF THE ENVIRONMENT THROUGH RECYCLING IN THE EUROPEAN COMMUNITY**



This symbol on the product, or on the packaging, shows that the product may not be disposed of with household waste. Instead it is your responsibility to dispose of the equipment at the designated collection points for recycling of waste electrical and electronic components. Differentiated waste collection and recycling of equipment at the time of disposal will help to conserve natural resources and to ensure that the equipment is recycled in such a way as to protect human health and the environment. For more information on the collection points for recycling equipment, please call the Town Hall, the waste disposal service or the shop where you made the purchase.

## **LIMITED MANUFACTURER'S WARRANTY**

### **Warranty period**

The warranty period shall commence on the purchase date of the product by the original purchaser. The product consists of multiple components, which are covered by a different warranty period. In particular, this limited warranty will be valid for a period of:

- a) twenty-four (24) months for the apparatus with exclusion of consumable parts and accessories listed in subparagraph (b);

- b) six (6) months for the following consumable parts: accessories and batteries.

Insofar as permitted by the relevant national legislation, the warranty period will not be renewed or extended, as a result of subsequent resale, repair or replacement of the product authorized by the manufacturer and/or NW. However parts of the product repaired or replaced product will be warranted for the remainder of the warranty period or for a period of sixty (60) days from the date of repair or replacement, whichever period is the longer.

### **What is not covered under warranty?**

1. This limited warranty does not cover:
  - a) the deterioration of the product due to normal wear and tear (including, without limitation, wear and tear on the battery) and/or;
  - b) defects resulting from bad use (including, without limitation, defects caused by sharp objects, deformations, pressures, drops, bumps, etc.) and/or
  - c) defects or damage caused by inappropriate use of the product and/or
  - d) defects resulting from other factors/acts outside the control of the manufacturer and/or of the reseller (E.g. failure SIM card).
2. This limited warranty does not cover defects caused by a battery short-circuit (electrical shock) or the visible broken seals closing the battery or that the battery was used in other equipments.
3. This limited warranty is not valid when open, change, or repair of the product by persons other than authorized centres.
4. This limited warranty is not valid in case of repairs carried out using unauthorized spare parts or if, at the discretion of the manufacturer and/or of the reseller, the product serial number or the component identifiers are shown to be removed, erased, defaced, altered or are illegible.
5. This limited warranty is not valid in case of prolonged exposure of the product to humidity, steam or the extreme thermal or environmental conditions or rapid changes in the presence of such conditions, corrosion, oxidation, spills or action of chemical products.

The manufacturer operates a policy of continuous development. The manufacturer and/or the reseller reserve the right to make changes and improvements to any product described in this document without prior notice.

Under no circumstances the manufacturer and/or the reseller shall be liable for any loss of data or profit or any special, incidental, consequential or indirect damages howsoever caused.

### ***Warranty repair***

Equipment repaired under warranty, according to warranty conditions listed above, are free both for workforce and replaced parts.

### ***Units outside the warranty period***

Equipment repaired out of warranty, according to warranty conditions listed above, will be charged to the customer at a cost established before. Any shipping costs and/or transport shall be borne by the customer.

### ***Units outside warranty no longer repairable***

If the equipment is out of warranty and absolutely no longer repairable the manufacturer and/or the reseller will not be obliged to restore the proper functioning of it but simply to return it to the customer declaring the absolute impossibility of repair.

## ***REVISION HISTORY OF INSTRUCTIONS:***

1.0 Initial instruction manual for firmware 2.6.

## APPENDIX TO THE INSTRUCTIONS FOR INSTALLING THE SOFTWARE ON YOUR PC:

### ***SailBrain Download and Upgrade Tools Software***

#### ***Installation and User manual ver 1.2***

#### **Index:**

<b>Introduction</b> .....	pag. 27
<b>Installing COM port Drivers</b>	
Installing Via "The Found New Hardware Wizard".....	pag. 27
Installing Using setup.exe.....	pag. 32
<b>Troubleshooting</b>	
Windows XP Cannot Find Drivers For My Device.....	pag. 33
Windows XP Forces Reboot after Installing a Device... Driver Installation Fails And Windows XP Gives Error Code 10.....	pag. 33
Windows XP Displays an Error and Then Terminates Installation.....	pag. 33
<b>Software tools installation</b>	
Installing and configure the SailBrain test and download tools software.....	pag. 34
<b>Log file browsing</b>	
Browse SailBrain Logs in NMEA format.....	pag. 37
Browse SailBrain Logs in KML format.....	pag. 37

#### **Introduction**

This document is intended to guide the reader through the process of installing SailBrain device tools software and the COM port driver for the Microsoft Windows operating system.

The SailBrain device is equipped with a dedicated port (Pic. 1.1), necessary to connect with a PC to download the event index file and all events stored in the internal flash memory.



Pic. 1.1

#### **Installing COM port Drivers**

##### **Installing Via "The Found New Hardware Wizard"**

To install COM port drivers under Windows XP, follow the instructions below:

- If a device of the same type has been installed on your machine before and the drivers that are about to be installed are different from those installed already, the original drivers need to be uninstalled. Please refer to the Uninstalling CDM Drivers (USB drivers) section of this document for further details of this procedure.
- Download the latest available CDM drivers from the FTDI web site ([www.ftdichip.com](http://www.ftdichip.com)) and unzip them to a location on your PC.
- If you are running Windows XP or Windows XP SP 1, temporarily disconnect your PC from the Internet. This can be done by either removing the network cable from your PC or by disabling your network card by going to the "Control Panel\Network and Dial-Up Connections", right-clicking on the appropriate connection and selecting "Disable" from the menu. The connection can be re-enabled after the installation is complete. This is not necessary under Windows XP SP 2 if configured to ask before connecting to Windows Update. Windows XP SP 2 can have the settings for Windows Update changed through "Control Panel\System" then select the "Hardware" tab and click "Windows Update".
- Connect the device to a spare USB port on your PC. If the device is based on the FT2232, the Microsoft composite device driver is automatically loaded in the background. Once the composite driver has



been installed Windows Found New Hardware Wizard will launch. If there is no available Internet connection or Windows XP SP 2 is configured to ask before connecting to Windows date, the screen shown in Picture 2.1 is displayed. Select "No, not this time" from the options available and then click "Next" to proceed with the installation. If there is an available Internet connection, Windows XP will silently connect to the Windows Update website and install any suitable driver it finds for the device in preference to the driver manually selected.



Pic. 2.1

- Select "Install from a list or specific location (Advanced)" as shown in Picture 2.2 below and then click "Next".



Pic. 2.2

- Select "Search for the best driver in these locations" and enter the file path in the combo-box ("C:\CDM 2.02.04" in Picture 2.3 below) or browse to it by clicking the browse button. Once the file path has been entered in the box, click next to proceed.



Pic. 2.3

- If Windows XP is configured to warn when unsigned (non-WHQL certified) drivers are about to be installed, the message dialogue shown in Picture 2.4 will be displayed unless installing a Microsoft WHQL certified driver. Click on "Continue Anyway" to continue with the installation. If Windows XP is configured to ignore file signature warnings, no message will appear.



Pic. 2.4

- The screen shown in the next picture will be displayed as Windows XP copies the required driver files.



Pic. 2.5

- Windows should then display a message indicating that the installation was successful. Click "Finish" to complete the installation for the first port of the device.



Pic. 2.6

- If the device is based on the FT2232, the Found New Hardware Wizard will continue by installing the USB Serial Converter driver for the second port of the FT2232 device. The procedure for installing the second port is identical to that for installing the first port from the first screen of the Found New Hardware Wizard. This is done automatically if the driver is Microsoft WHQL certified. If the device is not based on the FT2232, the COM port emulation driver is loaded as indicated in the following steps.
- The Found New Hardware Wizard will launch automatically to install the COM port emulation drivers. As above, select "No, not this time" from the options and click "Next" to proceed with the installation (Picture 2.7).



Pic. 2.7

- Select "Install from a list or specific location (Advanced)" as shown in Picture 2.8 below and then click "Next".



Pic. 2.8

- Select "Search for the best driver in these locations" and enter the file path in the combo-box ("C:\CDM 2.02.04" in Picture 2.9 below) or browse to it by clicking the browse button. Once the file path has been entered in the box, click next to proceed.



Pic. 2.9

- If Windows XP is configured to warn when unsigned (non-WHQL certified) drivers are about to be installed, the message dialogue shown in Picture 2.10 will be displayed unless installing a Microsoft WHQL certified driver. Click on "Continue Anyway" to continue with the installation. If Windows XP is configured to ignore file signature warnings, no message will appear.



Pic. 2.10

- The screen shown in Picture 2.11 will be displayed as Windows XP copies the required driver files.

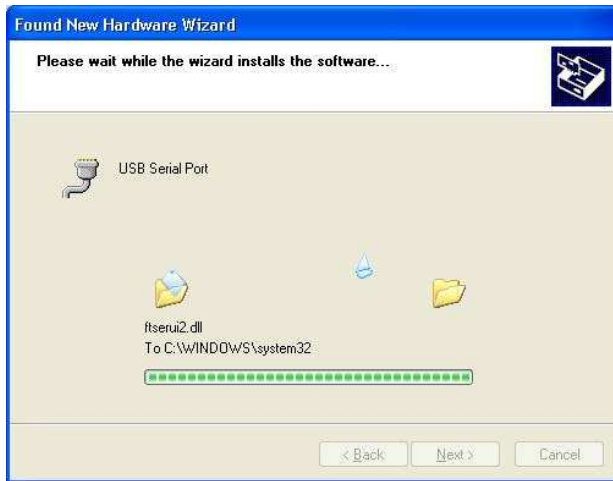

Pic. 2.11

- Windows should then display a message indicating that the installation was successful (Picture 2.12). Click "Finish" to complete the installation for the first port of the device.



Pic. 2.12

- If the device is based on the FT2232, the second port must also be installed. The procedure for installing the second port is identical to that for installing the first port from the first screen of the Found New Hardware Wizard for the USB Serial Port device. If the driver is Microsoft WHQL certified, this is done automatically.

- Open the Device Manager (located in "Control Panel\System" then select the "Hardware" tab and click "Device Manger") and select "View > Devices by Connection", the device appears as a "USB Serial Converter" with an additional COM port with the label "USB Serial Port" (Picture 2.13). If the device is based on the FT2232, two ports will be available from a composite USB device.

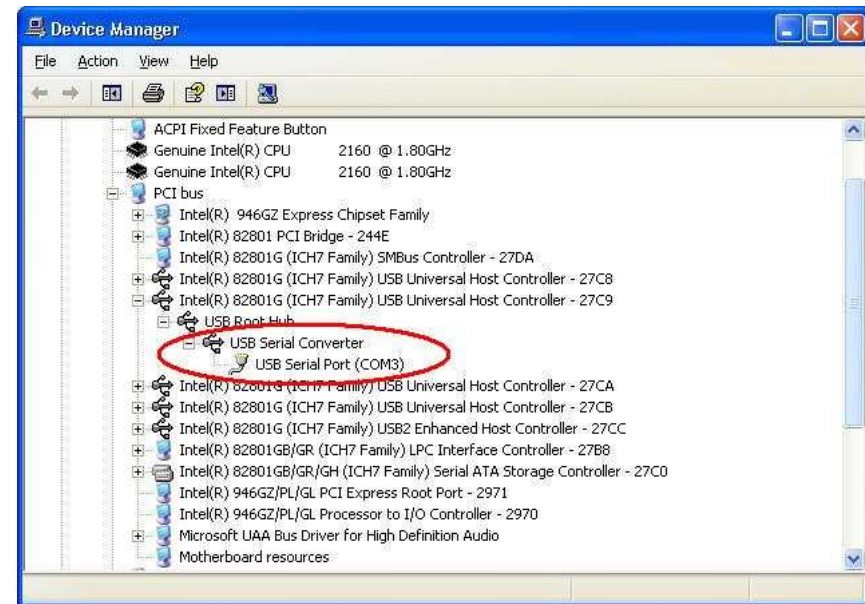

Pic. 2.13

- In the case of the FT2232, port A of the FT2232 will be installed as COMX and port B will be installed as COMX+1 where COMX is the first available COM port number.

## Installing Using setup.exe

In the case of a Microsoft XP certified driver package, it is possible install the driver package using the Driver Install tools. The simplest tool provided is the Driver Package Installer automatically. The current FTDI CDM driver package supports 32-bit and 64-bit systems through common INF files. DPInst has separate executables for 32-bit and 64-bit installation. This means that if a single solution is desired for 32-bit and 64-bit systems, the developer must be able to detect which version of DPInst is required for the system the driver is being installed on.

Double click on the icon

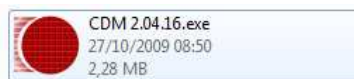

The procedure will start click on "Run" button

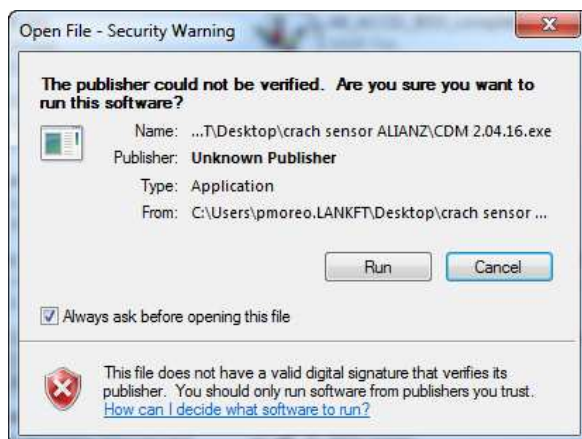

A popup menu will be appear to show the installation in progress, at the end the info box will disappear automatically.

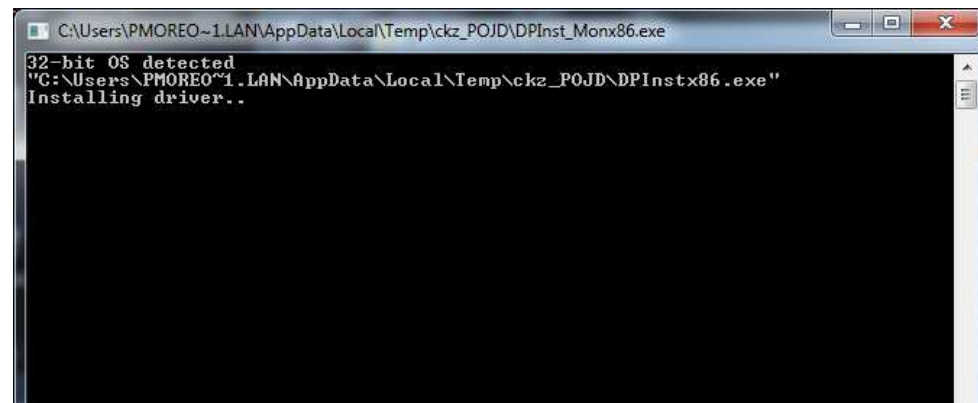

Insert the cable in the USB port the com port number will be displayed in the device managers, insert the USB into the device and the connection is done.

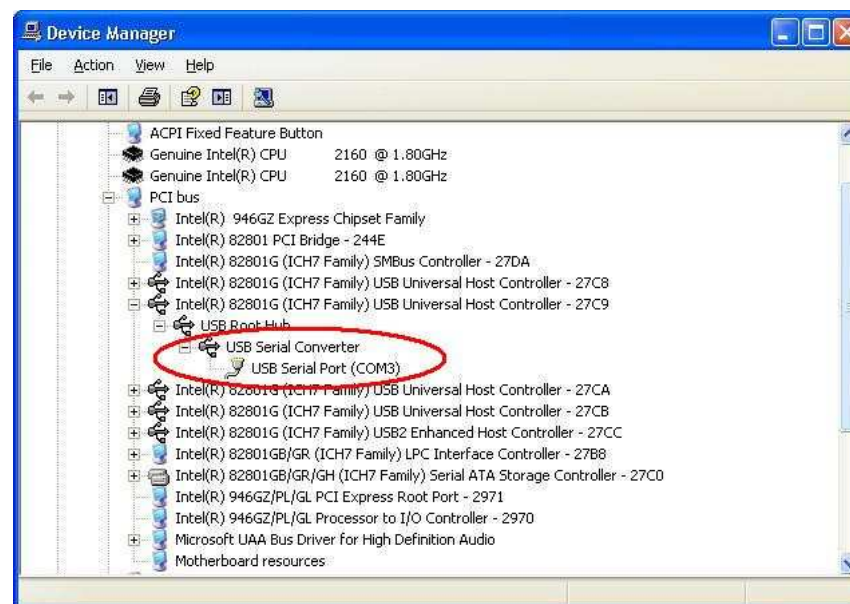

## Troubleshooting

### Windows XP Cannot Find Drivers For My Device

In this case, verify that the installation steps shown in the previous points have been carried out correctly.

### Windows XP Forces A Reboot After Installing a Device

This problem can occur if an application is accessing a file while the New Hardware Wizard is trying to copy it. This usually occurs with the FTD2XX.DLL file. Selecting not to restart the computer then unplugging and re-plugging the device may allow the device to function properly without restarting. Restarting the machine will allow the device to work correctly.

### Driver Installation Fails And Windows XP Gives Error Code 10

Windows error code 10 indicates a hardware error or failed driver installation. This error may appear if a device has insufficient power to operate correctly (e.g. plugged into a bus powered hub with other devices), or may indicate a more serious hardware problem. Also, it may be indicative of USB root hub drivers being incorrectly installed.

Please refer to the example schematics on the FTDI web site for standard device configurations. If the error persists, please contact the FTDI support department.

### Windows XP Displays An Error And Then Terminates Installation

If the following screen is displayed with this message, Windows XP has been configured to block the installation of any drivers that are not WHQL certified.



Pic. 2.14

Two options are available to successfully install the device. Either a certified version of the driver can be installed (if available) or the driver signing options can be changed to either warn or ignore to allow the installation to complete. To change the current driver signing setting, go to "Control Panel\System", click on the "Hardware" tab and then click "Driver Signing". The desired signing option may then be selected.

## Installing and configure the SailBrain Download and Upgrade Tools software

- Copy the folder SailBrain in C:\SailBrain and run the file **SailBrainDownloader.exe**

The welcome page start, DO NOT connect the device and click NEXT to continue



Pic. 3.1

Remove the metallic cap showed in picture 3.2 and insert the dedicated connector inside plug;



Pic. 3.2

- Insert the USB cable in the pc or the specific COM port previously installed as shown in the picture 3.3, the COM port will start to be scanned to search the one where SailBrain is connected;

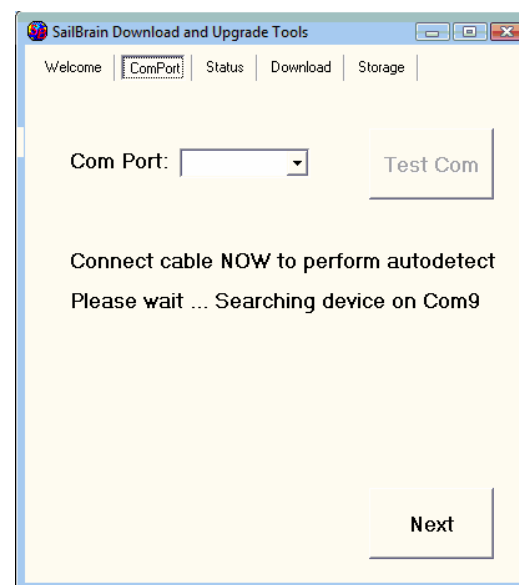

Pic. 3.3

- When COM port is detected, the status will show: Detecting Device...OK and indicate COM port where device is attached, as shown in Picture 3.4.

If procedure is not successful an error message will be shown, please check physical connection both on SailBrain device and on computer side.

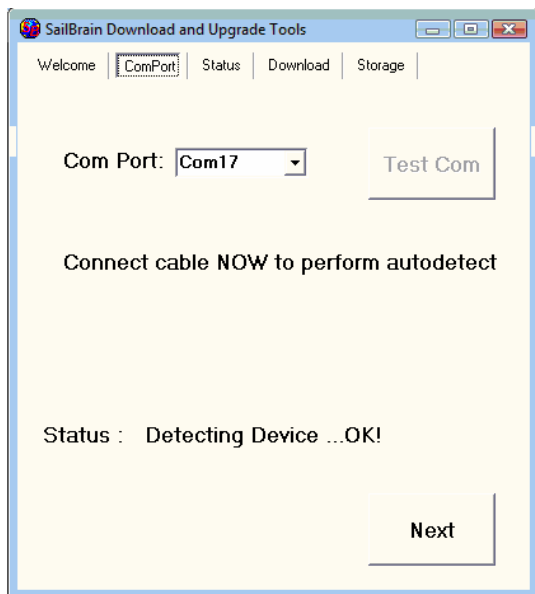

Pic. 3.4

- If the TestCom is ok click on "Next"

The menu status shows:

- Link connection with the SailBrain device (green box the link is ok and the SailBrain device is working properly)
- CPU Type: microcontroller model
- HW: Hardware release
- Device: device release
- DATEGmt (Cpu): internal date GMT
- TIMEGmt (Cpu): internal time GMT
- Code: device ID serial number
- Stat: device Status

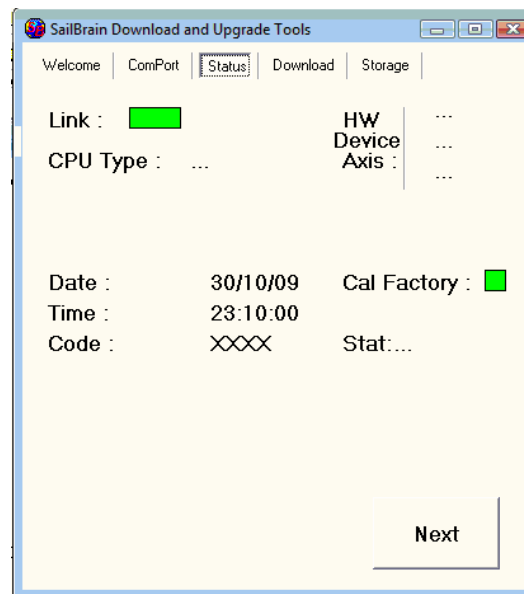

Pic.3.5

- Pressing Next button you will go to the menu where you can download the settings, index and all the events stored inside the module, press Download button and all the Log stored inside SailBrain device will be Downloaded:



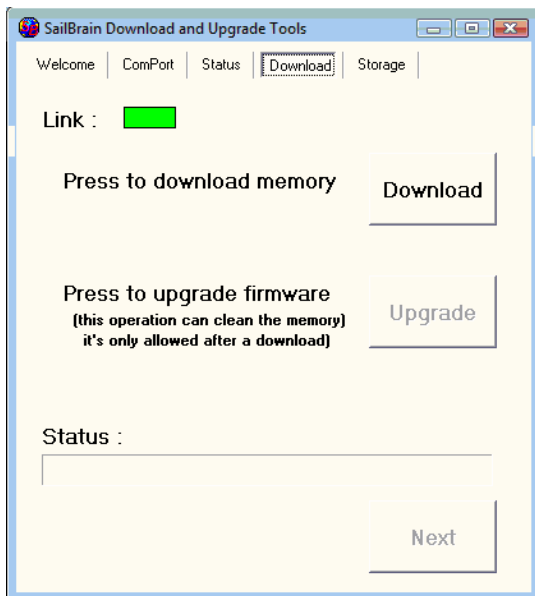

Pic. 3.6

In case of new firmware version you will have just to press Upgrade button and wait until Upgrade process is over;

- The last menu allows to save the logs with all information (Save button), file can be saved in standard NMEA format and in Google Kml, depending on "Save" check settings, see Picture 3.7:

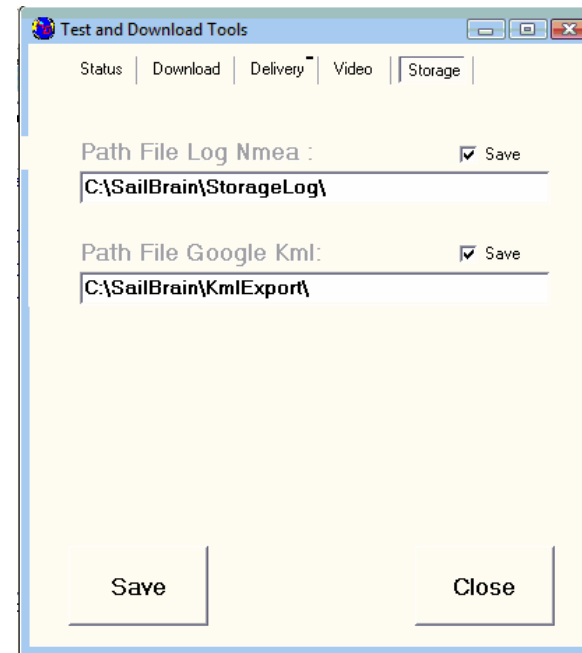

Pic. 3.7

## Log file browsing

### Browse SailBrain Logs in NMEA format

If you decide to save Log files downloaded from SailBrain device in NMEA format you will have in chosen directory Log files organized by date and time (see picture 4.1)

Name	Size	Type	Date Modified
Log_20101101_08.txt	1,024 KB	Text Document	11/12/2010 2:19 PM
Log_20101101_09.txt	600 KB	Text Document	11/12/2010 2:19 PM
Log_20101101_10.txt	590 KB	Text Document	11/12/2010 2:19 PM
Log_20101104_17.txt	550 KB	Text Document	11/12/2010 2:19 PM
Log_20101111_16.txt	428 KB	Text Document	11/12/2010 2:19 PM
Log_20101111_17.txt	297 KB	Text Document	11/12/2010 2:19 PM
Log_20101111_18.txt	245 KB	Text Document	11/12/2010 2:19 PM

Pic. 4.1

You can open NMEA log files with a normal text editor and browse inside it or load it with standard NMEA log reader (see picture 4.2)

```

$GPRMC,161946.000,A,04547.5834,N,0914.5759,E,0.44,0.00,20101111,,A*##
$GPRMC,161947.000,A,04547.5834,N,0914.5753,E,0.47,0.00,20101111,,A*##
$GPRMC,161948.000,A,04547.5834,N,0914.5748,E,0.49,0.00,20101111,,A*##
$GPRMC,161949.000,A,04547.5834,N,0914.5742,E,0.53,0.00,20101111,,A*##
$GPRMC,161950.000,A,04547.5842,N,0914.5736,E,0.57,0.00,20101111,,A*##
$GPRMC,161951.000,A,04547.5847,N,0914.5727,E,0.65,0.00,20101111,,A*##
$GPRMC,161952.000,A,04547.5849,N,0914.5720,E,0.69,0.00,20101111,,A*##
$GPRMC,161953.000,A,04547.5856,N,0914.5712,E,0.74,0.00,20101111,,A*##
$GPRMC,161954.000,A,04547.5859,N,0914.5703,E,0.81,0.00,20101111,,A*##
$GPRMC,161955.000,A,04547.5864,N,0914.5692,E,0.88,0.00,20101111,,A*##
$GPRMC,161956.000,A,04547.5869,N,0914.5680,E,0.97,0.00,20101111,,A*##
$GPRMC,161957.000,A,04547.5874,N,0914.5667,E,1.07,0.00,20101111,,A*##
$GPRMC,161958.000,A,04547.5876,N,0914.5656,E,1.16,0.00,20101111,,A*##
$GPRMC,161959.000,A,04547.5888,N,0914.5642,E,1.27,0.00,20101111,,A*##
$GPRMC,162000.000,A,04547.5893,N,0914.5630,E,1.36,0.00,20101111,,A*##
$GPRMC,162001.000,A,04547.5898,N,0914.5615,E,1.46,0.00,20101111,,A*##
$GPRMC,162002.000,A,04547.5908,N,0914.5600,E,1.55,0.00,20101111,,A*##
$GPRMC,162003.000,A,04547.5910,N,0914.5586,E,1.62,0.00,20101111,,A*##

```

Pic. 4.2

### Browse SailBrain Logs in KML format

If you decide to save Log files downloaded from SailBrain device in KML format, readable from Google Earth that you can get from URL: <http://earth.google.com/intl/en-uk/download-earth.html> you will have in chosen directory Log files organized by date and time (see picture 4.3)

Nome	Ultima modifica	Tipo	Dimensione
Log_20101101_08.Kml	12/11/2010 12.55	File KML	680 KB
Log_20101101_09.Kml	12/11/2010 12.55	File KML	1.220 KB
Log_20101101_10.Kml	12/11/2010 12.55	File KML	746 KB
Log_20101104_17.Kml	12/11/2010 12.55	File KML	450 KB
Log_20101111_16.Kml	12/11/2010 12.55	File KML	950 KB
Log_20101111_17.Kml	12/11/2010 12.55	File KML	783 KB
Log_20101111_18.Kml	12/11/2010 12.55	File KML	915 KB

Pic. 4.3

Here following an example of KML file on the map, where you can analyze point-by-point the track with details including Progressive, Time, Date, Speed and Heading of the boat:

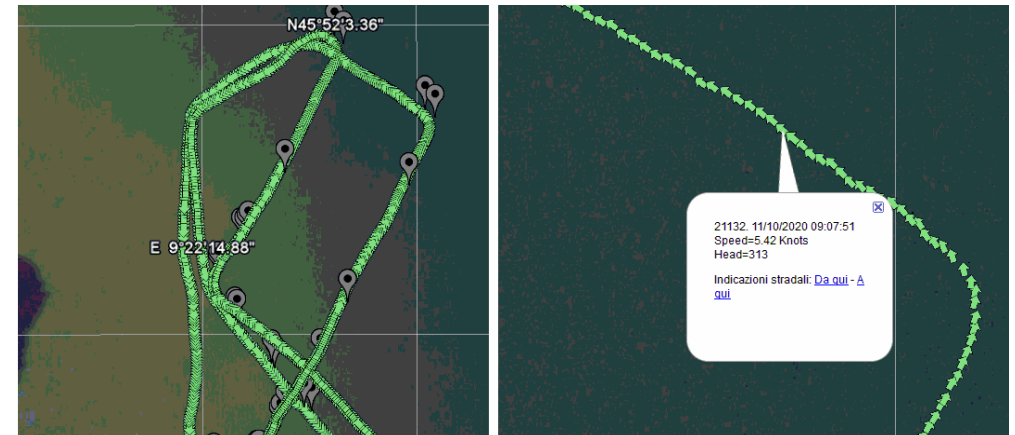

## **Note about this tool:**

**The manufacturer claims the right to make changing at any moment with no obligation to previously inform other parties.**