User Manual V1.1

ETHERNET

WIFI

Full Function Serial Network/Wireless Module

1	BRIEF INTRODUCTION	5
2	SUMMARIZE	5
2.1	TECHNICAL SPECIFICATIONS	5
2.2	HARDWARE EXPLANATION	6
2.2.1	<i>Mechanical Dimensions</i>	6
3	QUICK START	8
3.1	RESTORE FACTORY SETTINGS	8
3.2	CONFIGURATE NETWORK PARAMETER	8
3.3	CONFIGURATE SERIAL NETWORK PARAMETER	9
4	FUNCTION DESCRIPTION	9
4.1	SERIAL TO ETHERNET	9
4.2	SERIAL TO WIFI CLIENT	10
4.3	SERIAL TO WIFI AP	10
4.4	DEFAULT MODE	11
4.5	SERIAL WORK MODE SWITCHING	11
4.6	SERIAL-NET DATA CONVERSION	13
4.7	PARAMETER CONFIGURATION DIRECTION	15
5	WEB CONFIGURATION	16
5.1	WEB NETWORK CONFIGURATION	16
5.1.1	<i>Serial to Ethernet-dynamic ip</i>	16
5.1.2	<i>Serial to Ethernet-static ip</i>	17
5.1.3	<i>Serial to WIFI CLIENT-dynamic ip</i>	17
5.1.4	<i>Serial to WIFI CLIENT-static ip</i>	18
5.1.5	<i>Serial to WIFI AP</i>	18
5.2	WEB SERIAL CONFIGURATION	18
5.3	SUBMITTING ALTERATION	20
6	SERIAL AT COMMAND CONFIGURATION	20
6.1	ACCESS TO AT COMMAND MODE	20
6.2	AT COMMAND	20
6.2.1	<i>Net mode</i>	22
6.2.2	<i>wifi_conf</i>	22

6.2.3	<i>Channel</i>	23
6.2.4	<i>dhcpc</i>	23
6.2.5	<i>net_ip</i>	24
6.2.6	<i>net_dns</i>	24
6.2.7	<i>dhcpcd</i>	24
6.2.8	<i>dhcpcd_ip</i>	25
6.2.9	<i>dhcpcd_dns</i>	25
6.2.10	<i>dhcpcd_time</i>	25
6.2.11	<i>net_commit</i>	25
6.2.12	<i>out_trans</i>	26
6.2.13	<i>remoteip</i>	26
6.2.14	<i>remoteport</i>	26
6.2.15	<i>remotepro</i>	27
6.2.16	<i>timeout</i>	27
6.2.17	<i>mode</i>	27
6.2.18	<i>uart</i>	28
6.2.19	<i>uartpacklen</i>	28
6.2.20	<i>uartpacktimeout</i>	28
6.2.21	<i>escape</i>	28
6.2.22	<i>tcp_auto</i>	29
6.2.23	<i>save</i>	29
6.2.24	<i>reconn</i>	29
6.2.25	<i>ver</i>	29
6.3	AT COMMAND CONTROL CODE ROUTION	30
6.3.1	<i>Inquiry configuration information</i>	30
6.3.2	<i>Serial to Ethernet(Dynamic ip address)</i>	31
6.3.3	<i>Serial to Ethernet(static ip address)</i>	32
6.3.4	<i>Serial to wifi client(dynamic IP address)</i>	33
6.3.5	<i>Serial to wifi client(static IP address)</i>	33
6.3.6	<i>Serial to wifi AP</i>	34
6.3.7	<i>Restore factory value</i>	35
7	SERIAL CONFIGURATION TOOLS	36
7.1	SEARCHING THE MODULE	38
7.2	SET EACH PARAMETERS	38



7.3	SUBMIT THE CONFIGURATION	39
7.4	USER DATA RETENTION	40
7.5	INQUIRY CONFIGURATION	40
7.6	ACCESS TO TRANSPARENT TRANSMISSION MODE.....	40
7.7	RESTORE FACTORY FACTORY VALUE SETTING	40
8	DEVICE SEARCH TOOLS.....	41
9	RESTORE FACTORY SETTINGS	42
10	FIRMWARE UPGRADE	43
	APPENDIX A DOCUMENT REVISION RECORD.....	43

1 Brief Introduction

The module is a new low-cost embedded UART-ETH-WIFI module (serial port - Ethernet - Wireless network)

This product is an embedded module based on the universal serial interface network standard, built-in TCP / IP protocol stack, enabling the user serial port, Ethernet, wireless network (wifi) interface between the conversions.

Through the module, the traditional serial devices do not need to change any configuration; data can be transmitted through the Internet network. Provide a quick solution for the user's serial devices to transfer data via Ethernet.

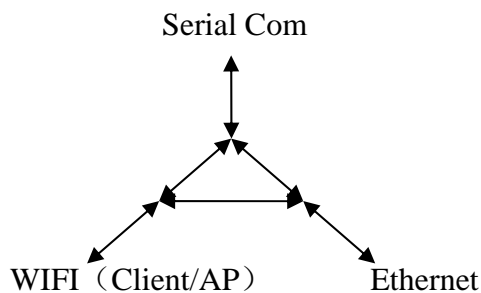

Picture 1.F-structure

2 Summarize

2.1 Technical Specifications

Table 2-1 Technical Specifications

Network standard	wireless: IEEE 802.11n、IEEE 802.11g、IEEE 802.11b
	wired: IEEE 802.3、IEEE 802.3u
Wireless transmission rate	11n: maximum up to 150Mbps 11g: maximum up to 54Mbps 11b: maximum up to 11Mbps
Tracks number	1-14
Frequency range	2.4-2.4835G
Emission power	12-15DBM
Interface	2 Ethernet, 2 serial, 1 usb (host/slave) ,GPIO
Antenna	
Antenna type	Onboard antenna / External Antenna

Functional Parameters	
WIFI work mode	Client/AP/Router
WDS Function	Support WDS wireless bridge connection
Wireless security	Wireless MAC address filtering
	Wireless security function switch
	64/128/152 bit WEP encryption
	WPA-PSK/WPA2-PSK、WPA/WPA2 security mechanism
Network management	Remote Web management
	Configuration file import and export
	WEB software upgrade
Serial to Ethernet	
Maximum transmission rate	230400bps
TCP connection	Max connection number>20
UDP connection	Max connection number>20
Serial baud rate	50~230400bps
Other Parameters	
Status indicator	Status indicator
Environmental standard	Operating temperature: -20-70℃
	Operating humidity: 10%-90%RH (noncondensing)
	Storage temperature: -40-80℃
	Storage humidity: 5%-90%RH (noncondensing)
Additional properties	Frequency bandwidth optional: 20MHz、40MHz, Automatic

2.2 Hardware Explanation

2.2.1 Mechanical Dimensions

Mechanical Dimensions is shown in the following picture:

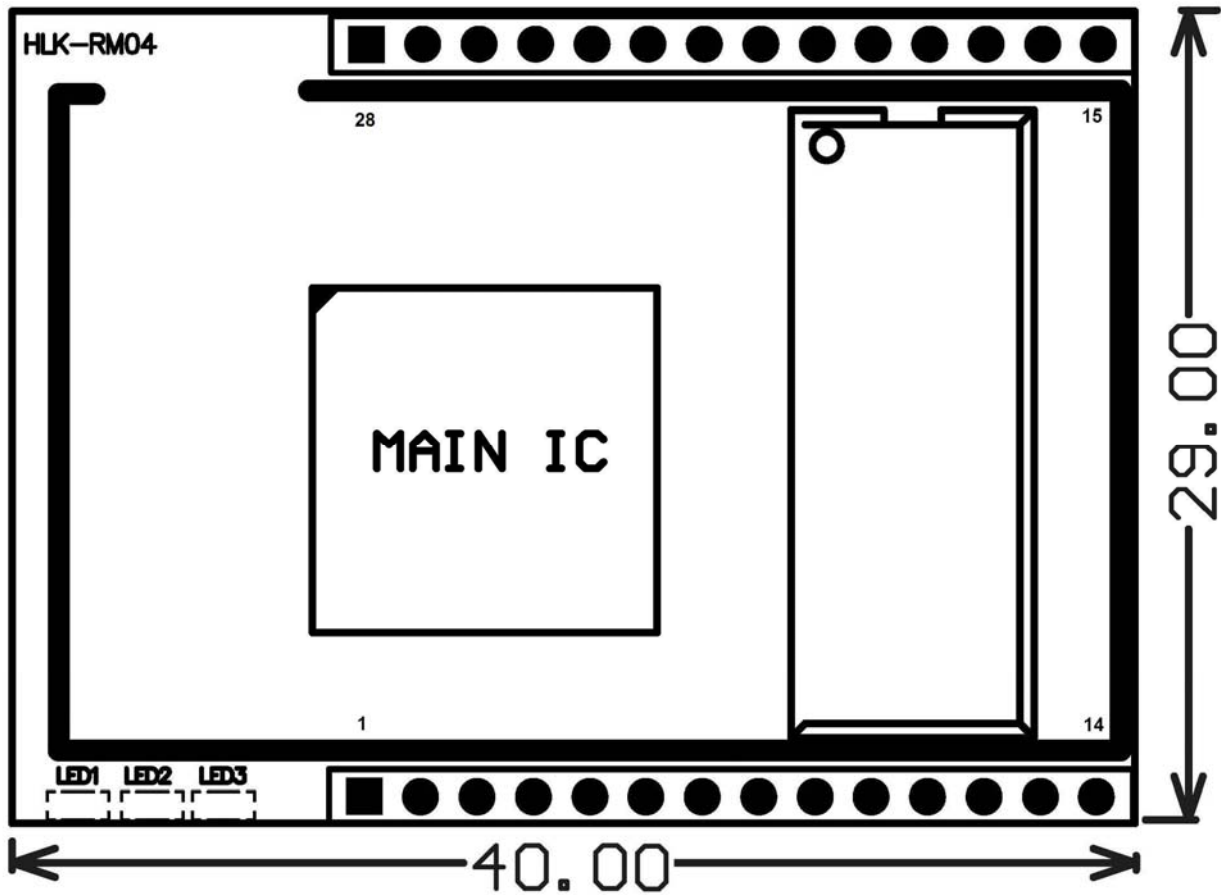

Picture2.Dimensions Unit:mm

2.2.2 Pins Interface

The Pin of this product as shown above is defined as follows:

Table2-2 module pin interface

No.	Function	Direction	Explanation
1	VCC5V	A	Supply Voltage, 5V+/-10%
2	GND	GND	Analogue Ground
3	WIFILED	O	WLAN Activity LED
4	VO3.3	I	3.3V Output (Suuport Atmost 300mA)
5	LINK1	I/O	10/100 PHY Port #1 activity LED
6	N/A		Reserved
7	N/A		Reserved
8	GPIO0		General GPIO Reserved
9	GPIO1		General GPIO Reserved
10	ES/RST	I/O	Exit transparent transmission mode/Restore factory

11	TXOP1	I/O	10/100 PHY Port #1 TXP
12	TXON1	I/O	10/100 PHY Port #1 TXN
13	RXIP2	I/O	10/100 PHY Port #2 TXP
14	RXIN2	I/O	10/100 PHY Port #2 TXN
15	RXIN1	I/O	10/100 PHY Port #1 RXN
16	RXIP1	I/O	10/100 PHY Port #1 RXP
17	TXON2	I/O	10/100 PHY Port #2 OXN
18	TXOP2	I/O	10/100 PHY Port #2 OXP
19	GPIO2	I	General GPIO Reserved
20	UART_RX	I	UART RXD.
21	UART_TX	O	UART TXD.
22	GPIO3	I	General GPIO Reserved
23	LINK2	I/O	10/100 PHY Port #2 activity LED
24	GPIO4	O	General GPIO Reserved
25	WPS/RST	I	WiFi Protected Setup /Restore factory value
26	GPIO5	O	General GPIO Reserved
27	VO1.8	Power Out	1.8V Output (Suupport Atmost 300mA)
28	VCC5V	Power In	Supply Voltage, 5V+/-10%

Notes: The I/O port level voltage is 3.3 V

3 Quick Start

3.1 Restore factory settings

In order to ensure that all of the configuration process is correct, bring the module to restore the factory settings first. If it is already in factory mode, you can skip this step. Power on the module with 5V (350mA) electric source, wait about 30 seconds, After starting, Lower ES/RST pin more than Trst, release of ES/RST feet, the system will automatically restart. After rebooting the system the module is already in Factory mode.

3.2 Configurate network parameter

Set the PC to static IP mode and then connect it with the module via Ethernet or wifi. The IP address is set to 192.168.16.100/255.255.255.0, gateway 192.168.16.254. The (wifi default ssid and the default password, see this document.) open the browser <http://192.168.16.254>, enter the web configuration page, default user name and password is admin / admin. Modify the network

parameters through the web. Now, the module's IP address is 192.168.16.254. Configuration details can be seen in 5.1.

3.3 Configure serial network parameter

Opens the browser <http://192.168.16.254/ser2net.asp>, enter the serial-to-network web configuration page. Configure the serial-to-network parameters as needed through a web page. Configuration details can be seen in 5.2.

4 Function Description

The module can be divided into four major modes: default mode, serial to Ethernet, serial to WIFI CLIENT and serial to WIFI AP.

4.1 Serial to Ethernet

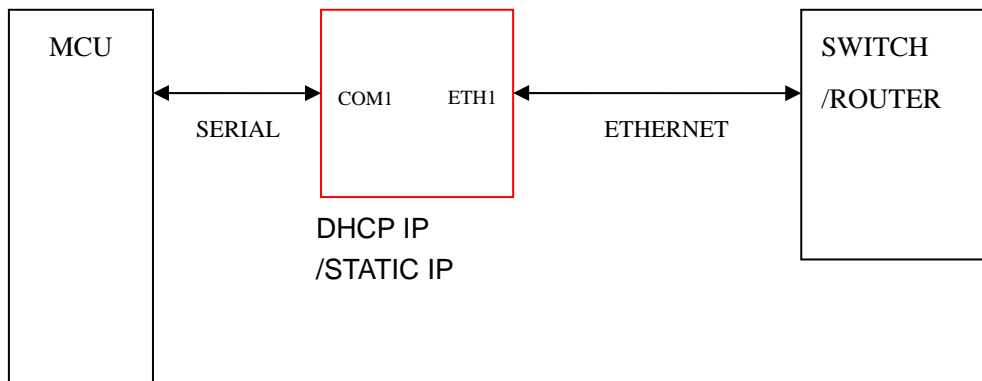

Chart3.serial to Ethernet model

In this mode, ETH1 enable, WIFI, ETH2 function close. Through the appropriate settings, the data between COM1 and ETH1 network can achieve mutual conversion.

Ethernet can be configured as dynamic IP address (DHCP), can also be configured as static IP address (STATIC).

4.2 Serial to WIFI CLIENT

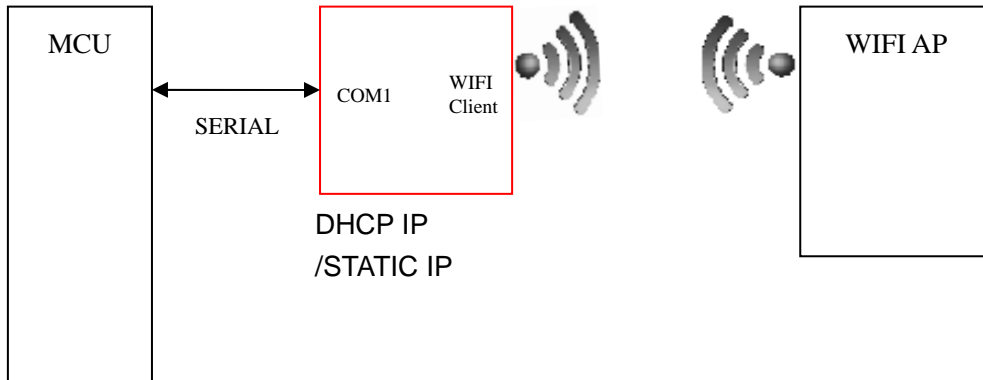

Chart 4.Serial to WIFI CLIENT model

In this mode, WIFI enable, module works in the client mode, ETH1, ETH2 function close. Through the appropriate settings, the data between COM1 and WIFI network can achieve mutual conversion.

WIFI CLIENT can be configured as dynamic IP address (DHCP), can also be configured as static IP address (STATIC).

WIFI safety: support all encryption methods at present.

4.3 Serial to WIFI AP

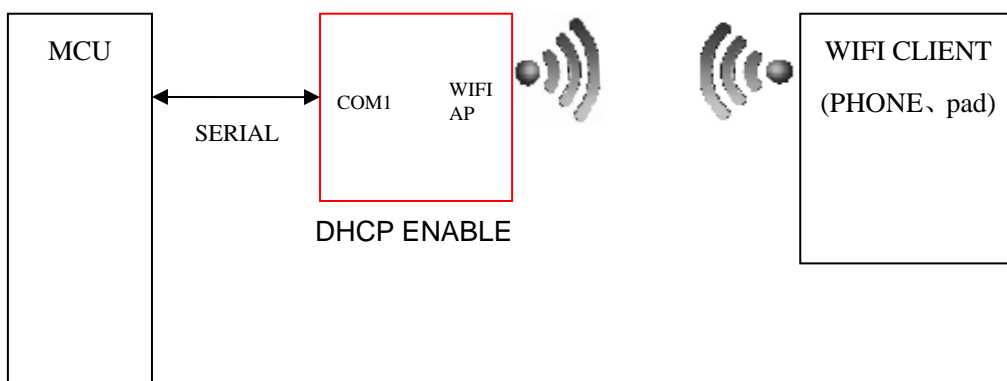

Chart 5. Serial to WIFI AP model

In this mode, WIFI enable, module works in the AP mode, ETH1, ETH2 function close.

Through the appropriate settings, the data between COM1 and WIFI network can achieve mutual conversion.

WIFI safety: support all encryption methods at present.

In this mode, WIFI device can connect with the module and become the device under WIFI LAN.

4.4 Default mode

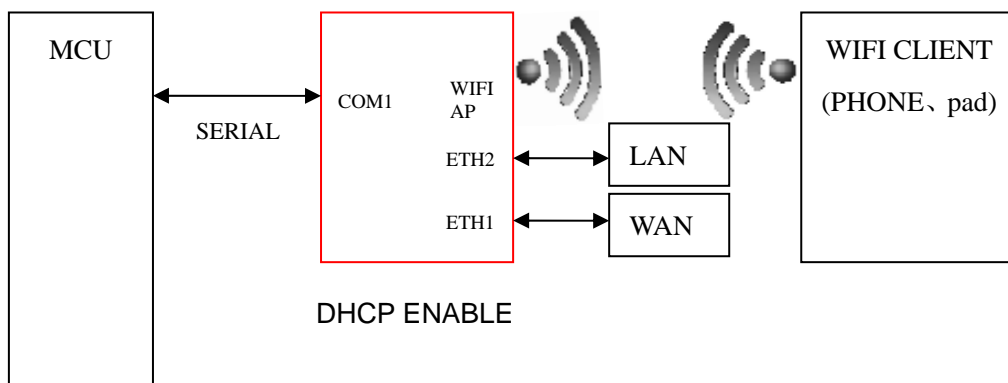

Chart 6.Default mode model

In this mode, WIFI enable, module works in the AP mode, ETH1, ETH2 function enable. ETH1 works as WAN, ETH2 works as LAN. Through the appropriate settings, the data between COM1 and network can achieve mutual conversion.

WIFI safety: support all encryption methods at present.

In this mode, WIFI device can connect with the module and become the device under WIFI LAN.

WAN default IP is dynamic IP address. LAN, WIFI for the same local area network, enabled by default DHCP server.

4.5 Serial work mode switching

Module serial work status is defined as two modes: transparent transmission mode, the AT command mode

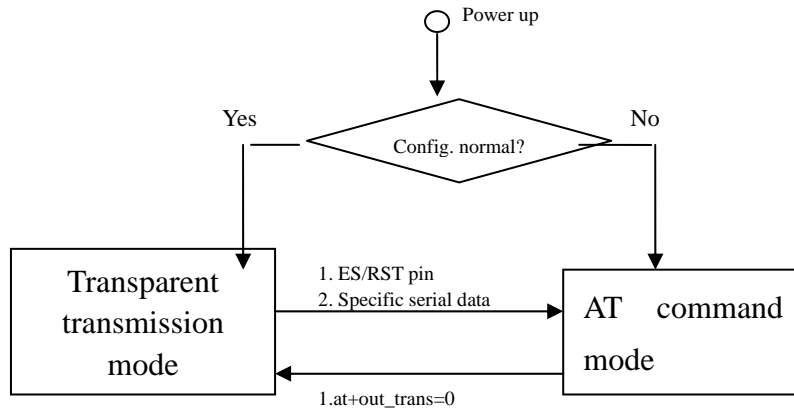

Chart 7.Serial work mode switching

After power-on normally, the module will check whether the current network serial port configuration is normal, if the network connection is normal, the module automatically enters transparent transmission mode, and otherwise the module will enter AT command mode.

There are two kinds of methods for transparent mode entering AT command mode:

1. ES/RST pin

In any state, to maintain the time of ES / RST pin' low level greater than T_{es} and less than T_{rst} , the module will immediately enter the AT command mode.

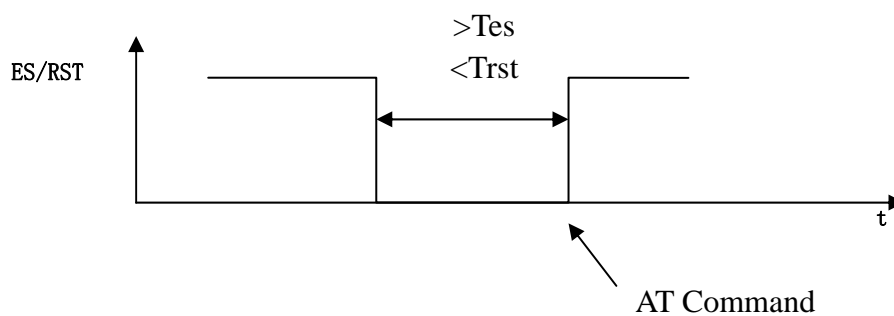

Chart 8. ES/RST Exit transparent transmission mode

2. Specific serial data

When serial exit pass-through feature is turned on, you can send specific serial data to make the module exit transparent transmission mode. Serial exit pass-through process is as follows:

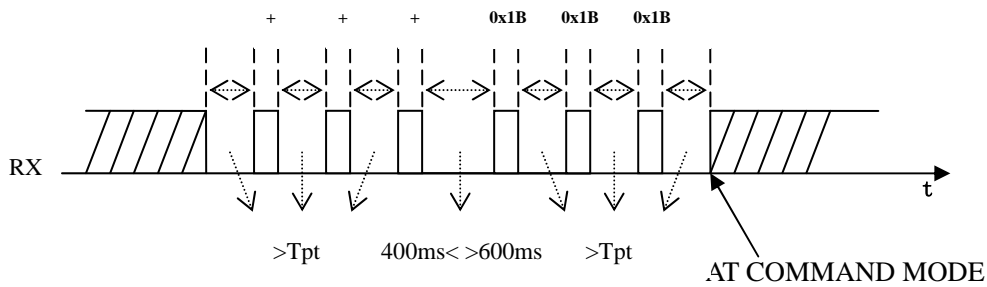

Chart 9. Serial exit transparent transmission mode

Notes:

T_{pt} : Serial framing time

The group frame time interval is greater than continuous send three "+", and then wait for about 500ms ($400ms < > 600ms$) framing interval is greater than the time to send three consecutive 0x1B. The modules will exit the transparent transmission mode.

Notes: This function only can be used in the case of serial exit pass-through feature is turned on.

4.6 Serial-net data conversion

There are four mode for serial-net conversion: TCP Server、TCP Clinet、UDP Server、UDP Client。

TCP Server

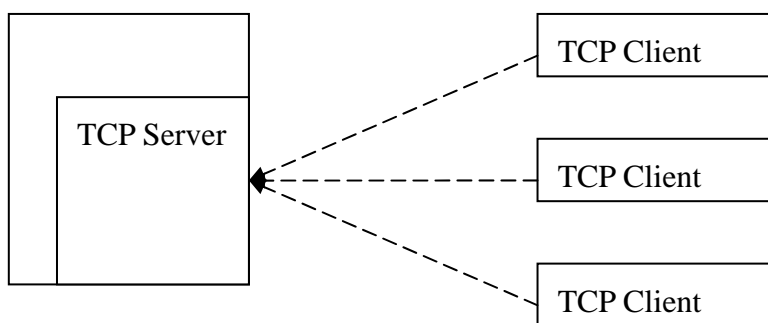

Chart 10. TCP Server

In this mode, the module is listening on the specified port, waiting for TCP Client connection, if connected, all TCP data is sent directly to the serial port end, the data of the serial end sent to TCP Clie n end

TCP Client

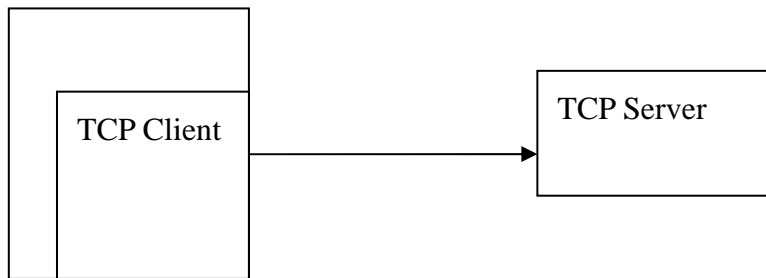

Chart 11.TCP Client

In this mode, the module is connected to the specified domain / IP port. All the data sent from the TCP Server-side end will be sent directly to the serial port, the data from the serial end sent to the TCP Server-side. Abnormal network disconnect will cause the module active reconnect. TCP Active reconnection function enable, TCP Server initiative disconnected, the module will immediately take the initiative to reconnect, and otherwise the module will not reconnect.

UDP Server

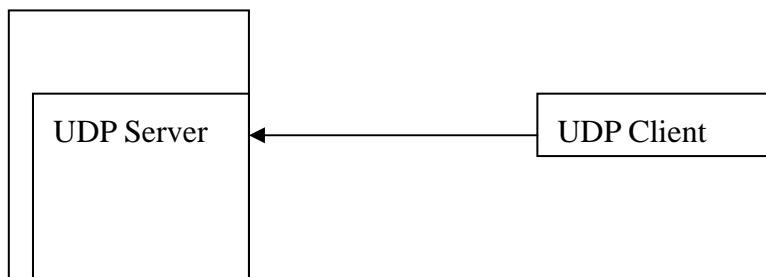

Chart 12.UDP Server

In this mode, the module opens the local designated port, once received the data sent to the port, the module will send the data to the serial port, and record the remote ip, port. The module will record only the last information on the remote connection. Serial received data will be sent directly to the recorded remote ip, port.

UDP Client

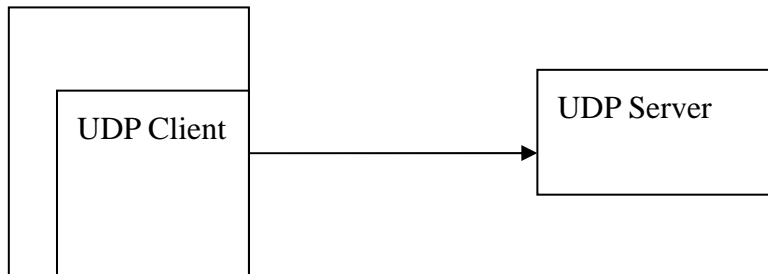

Chart 13.UDP Client

In this mode, the module directly sends the serial data to the specified ip, port. The serial data returned from the server-side will be distributed to serial port.

4.7 Parameter configuration direction

The module provides two ways for the configuration parameters:

- 1.Web page;
2. Serial AT command.

Access to WEB configuration page requires the confirmation of the module's IP addresses, as well as the user name and password that authenticated by WEB.

Configuring parameters through the serial port AT command needs to make the module into the AT command mode first.

Serial configuration tool `module_CONFIG`: Configure the module through AT command, provide a easier and convenient configuration process through the configuration combination of each parameter.

5 WEB configuration

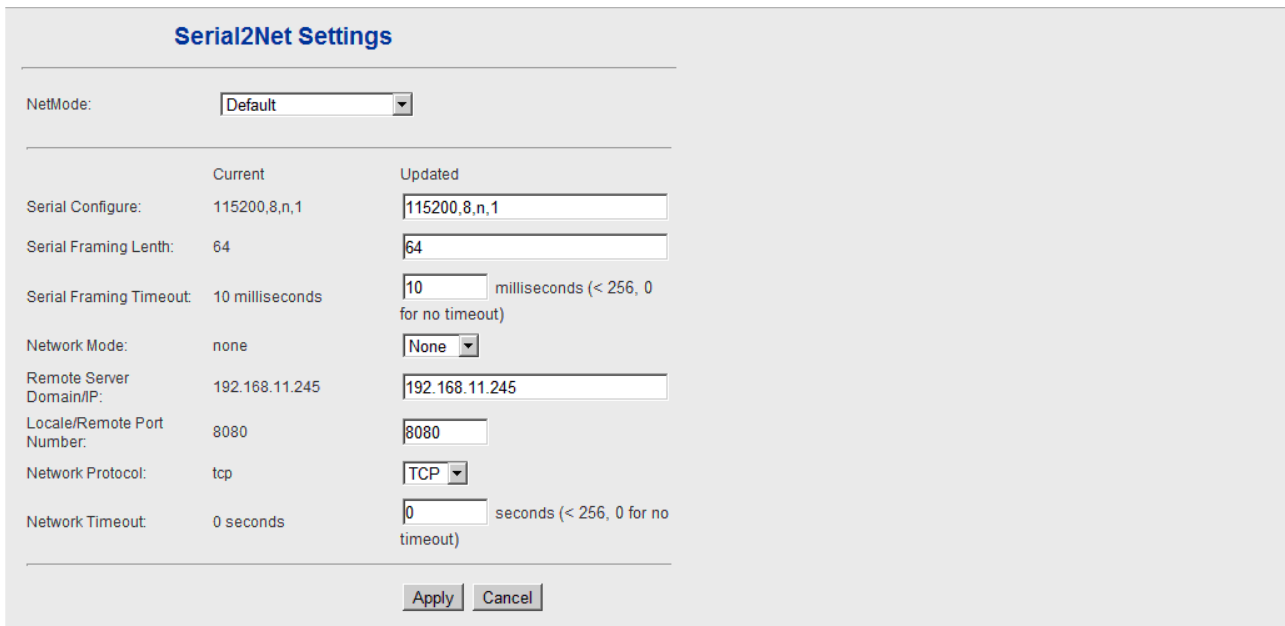

The image shows a web configuration page titled "Serial2Net Settings". It features a "NetMode" dropdown menu set to "Default". Below this is a table with two columns: "Current" and "Updated". The table contains the following settings:

	Current	Updated
Serial Configure:	115200,8,n,1	115200,8,n,1
Serial Framing Lenth:	64	64
Serial Framing Timeout:	10 milliseconds	10 milliseconds (< 256, 0 for no timeout)
Network Mode:	none	None
Remote Server Domain/IP:	192.168.11.245	192.168.11.245
Locale/Remote Port Number:	8080	8080
Network Protocol:	tcp	TCP
Network Timeout:	0 seconds	0 seconds (< 256, 0 for no timeout)

At the bottom of the form are "Apply" and "Cancel" buttons.

Chart 7.WEB configuration page

Through the correct module address (default address:http://192.168.16.254/ser2net.asp),you can access to the WEB configuration page.

The page can be divided into 3 areas:

- 1 Network configuration area
- 2 Serial function configuration areas
- 3 Configuration submit area

5.1 WEB network configuration

Net mode selection:

- Default – default work mode
- ETH-SERIAL – Serial to Ethernet
- WIFI (CLIENT)-SERIAL – serial to WIFI CLIENT
- WIFI (AP)-SERIAL) – Serial to WIFI AP

Choose different work mode, the web will show you different page.Mode configuration page is as follows:

5.1.1 Serial to Ethernet-dynamic ip

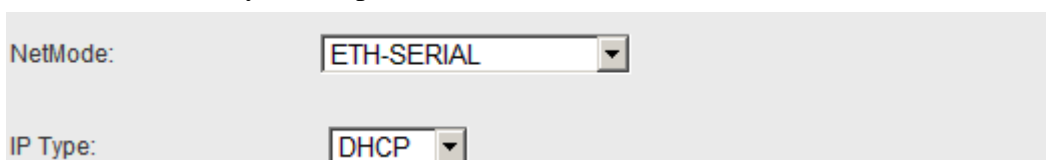

The image shows a configuration page for "Serial to Ethernet-dynamic ip". It features a "NetMode" dropdown menu set to "ETH-SERIAL" and an "IP Type" dropdown menu set to "DHCP".

Chart 8. Serial to Ethernet-dynamic

5.1.2 Serial to Ethernet-static ip

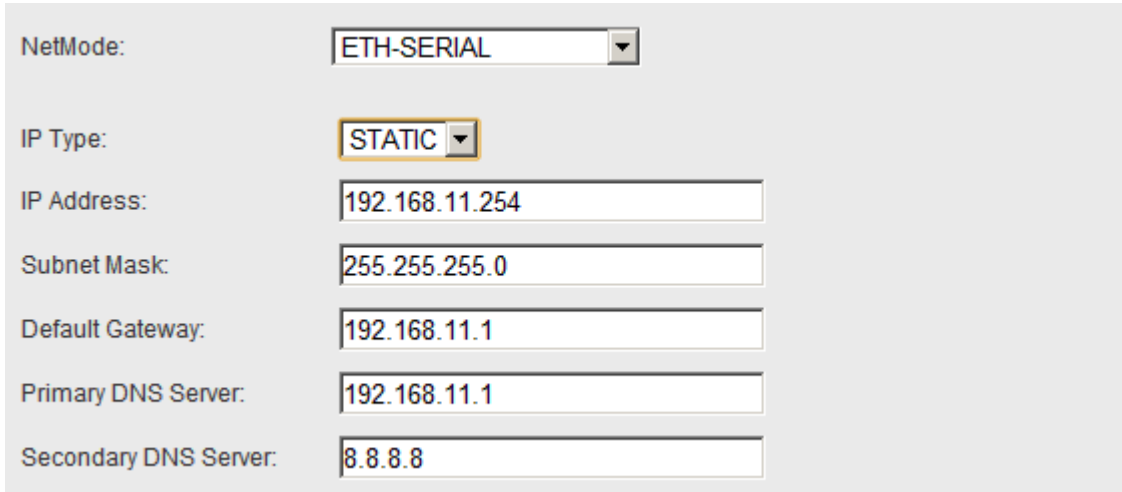

NetMode: ETH-SERIAL

IP Type: STATIC

IP Address: 192.168.11.254

Subnet Mask: 255.255.255.0

Default Gateway: 192.168.11.1

Primary DNS Server: 192.168.11.1

Secondary DNS Server: 8.8.8.8

Chart 9. Serial to Ethernet-static

5.1.3 Serial to WIFI CLIENT-dynamic ip

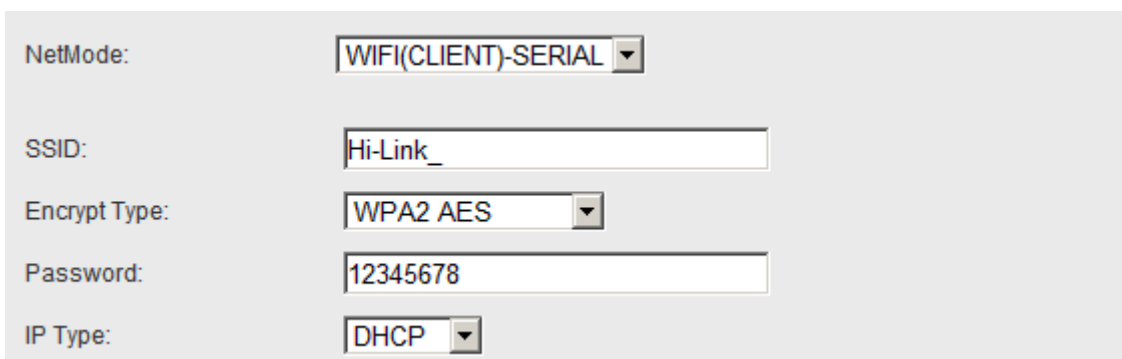

NetMode: WIFI(CLIENT)-SERIAL

SSID: Hi-Link_

Encrypt Type: WPA2 AES

Password: 12345678

IP Type: DHCP

Chart 10. serial to WIFI CLIENT dynamic

5.1.4 Serial to WIFI CLIENT-static ip

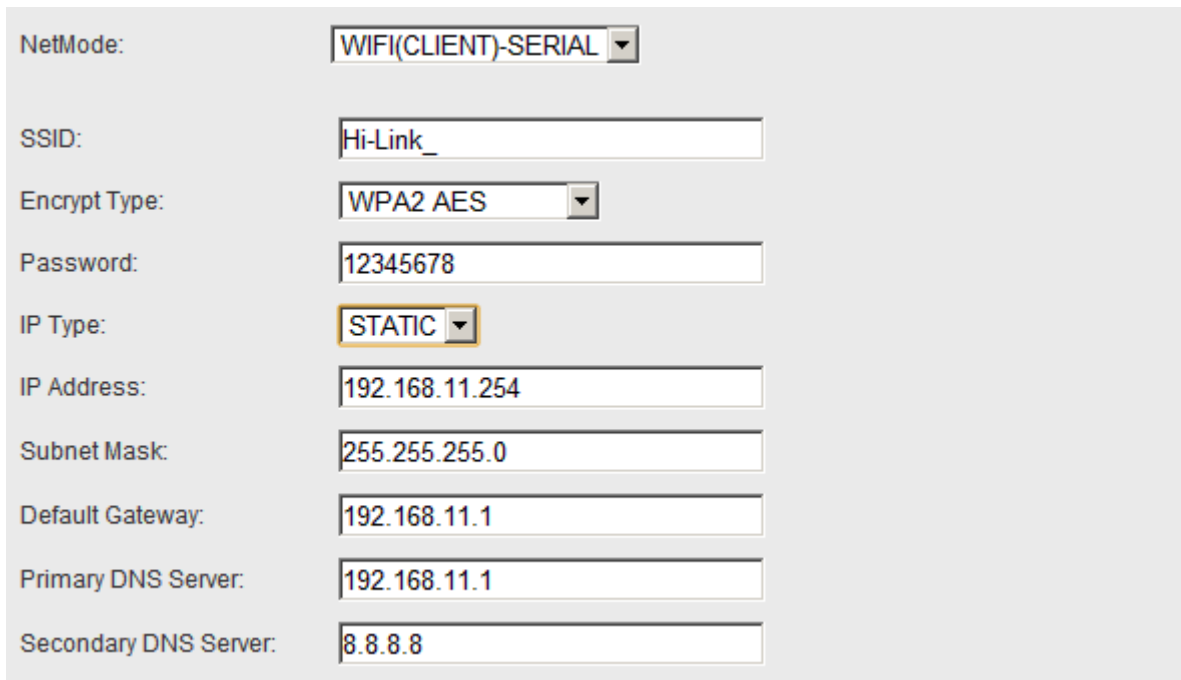

NetMode:	WIFI(CLIENT)-SERIAL
SSID:	Hi-Link_
Encrypt Type:	WPA2 AES
Password:	12345678
IP Type:	STATIC
IP Address:	192.168.11.254
Subnet Mask:	255.255.255.0
Default Gateway:	192.168.11.1
Primary DNS Server:	192.168.11.1
Secondary DNS Server:	8.8.8.8

Chart 11. Serial to WIFI CLIENT-static

5.1.5 Serial to WIFI AP

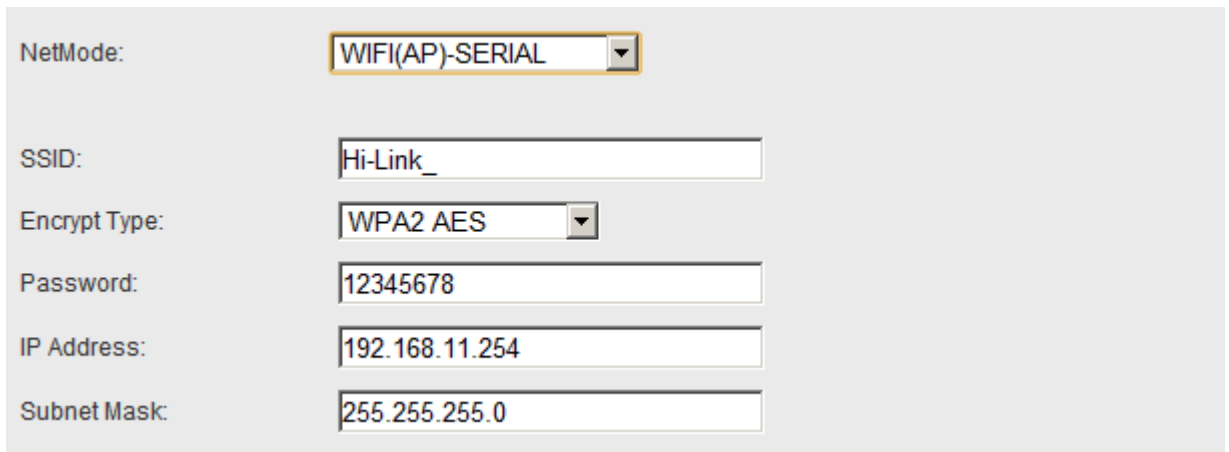

NetMode:	WIFI(AP)-SERIAL
SSID:	Hi-Link_
Encrypt Type:	WPA2 AES
Password:	12345678
IP Address:	192.168.11.254
Subnet Mask:	255.255.255.0

Chart12. Serial to WIFI AP

5.2 WEB serial configuration

Serial Web configuration page (ser2net.asp) is as follows:

Serial Settings

	Current	Updated
Serial Configure:	115200,8,n,1	<input type="text" value="115200,8,n,1"/>
Serial Framing Lenth:	64	<input type="text" value="64"/>
Serial Framing Timeout:	10 milliseconds	<input type="text" value="10"/> milliseconds (< 256, 0 for no timeout)
Network Mode:	client	<input type="text" value="Client"/>
Remote Server Domain/IP:	192.168.11.245	<input type="text" value="192.168.11.245"/>
Locale/Remote Port Number:	8080	<input type="text" value="8080"/>
Network Protocol:	udp	<input type="text" value="UDP"/>
Network Timeout:	0 seconds	<input type="text" value="0"/> seconds (< 256, 0 for no timeout)
		<input type="button" value="Submit"/>

Current shows the current configuration , **Updated** shows the current revision parameters。
Submit submit the revision.

Serial Configure: Serial configuration.fomat: Baud rate, data bits, parity bit, stop bit.
For example: “115200,8,n,1”.

Serial Framing Lenth: The Lenth of Serial Framing

Serial Framing Timeout: The time of Serial Framing

Network Mode: choose Client、Server or none。

Remote Server Domain/IP: Remote Server Domain/IP address

For expmale: 192.168.11.245

Locale/Remote Port Number: The specified parameter is not the same under the different network modes. Client specifies the port number on the remote, Server specified local port number.

Network Protocol: Use tcp or udp Protocol

Network Timeout: Under the server network mode, no data transmission within the timeout period, the connection will be disconnected. 0 specifies never disconnected.

5.3 Submitting Alteration

Click the button 'Apply' to submit the configuration of the current page. If some parameters of the network have changed, the submission process may take about 25 seconds. If you only modify the serial functional configuration, the submission process will be completed soon.

Click the button 'Cancel' to reload the page, the modified configuration will be lost.

6 Serial AT command configuration

6.1 Access to AT command mode

Module in network fault, such as fault allocation situation will automatically exit the transparent transmission mode, enter AT instruction mode. In any condition, keep ES/RST feet low level of time but more than T_{es} and less than T_{rst} , the module will enter AT instruction mode immediately.

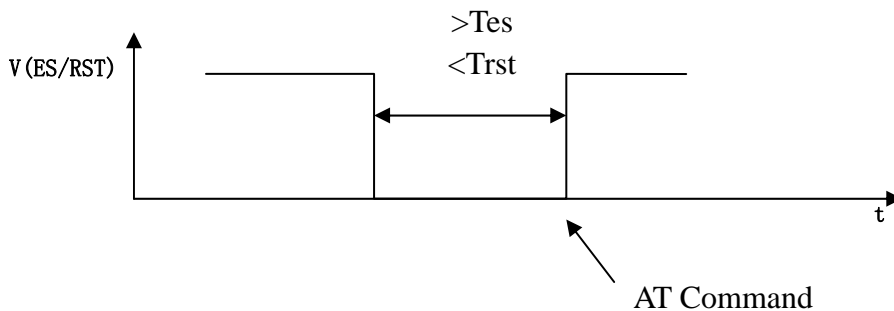

6.2 AT Command

In AT mode, you can configure the system parameters through the serial port AT instruction. Instruction format is as follows:

At+[command]=[value]\r

According to the different command, module will return a different return value.

For example: "at+remoteip=192.168.11.133\n" set remote ip address as 192.168.11.133.

For example: "at+remoteip=? \n" Inquiry remote ip address.

At command is as follows:

netmode	Network mode
wifi_conf	Wifi configuration
dhcpc	Dhcp client configuration
net_ip	Network ip address
net_dns	Network dns address
dhcpd	Dhcp server configuration
dhcpd_ip	Dhcp server ip address
dhcpd_dns	Dhcp server dns address
dhcpd_time	Dhcp sever time allocation
net_commit	Submit network configuration
out_trans	Exit transparent transmission mode
remoteip	Remote server domain name or IP address
remoteport	The local or distal port number
remotepro	Network Protocol type
timeout	Network timeout
mode	Network mode
uart	Serial port configuration
uartpacklen	Serial group frame length
uartpacktimeout	Serial framing time
escape	Save the configuration and start service
tcp_auto	Restart services
save	Restore factory value settings
reconn	Restart the module
restore	The version of module
reboot	reboot module
ver	module version
CLport	TCP / UDP CLIENT local port
RTS	serial output instruction (485)
XON_XOFF	XON / XOFF flow control enabled
net_wanip	wan ip address
tcp_client_check	TCP CLIENT remote status detection
S2N_Stat	serial functional status

Get_MAC	get the MAC address
wifi_ConState	WiFi CLIENT connection status
wifi_Scan	WiFi Scan
suspend	the system hangs
C2_uart	Serial 2 port configuration
C2_mode	Serial 2 port network mode
C2_remoteip	serial 2 domain name or IP address of the remote server
C2_port	local or remote serial port number 2
C2_CLport	local port serial 2TCP/UDP CLIENT
C2_protocol	serial two types of network protocols
C2_timeout	serial port 2 Network Timeout
C2_uartpacklen	Serial 2 port group frame length
C2_uartpacktimeout	Serial 2 port group frame time
C2_tcp_auto	serial 2TCP automatic reconnection
C2_tcp_client_check	serial 2TCP CLIENT remote status detection

6.2.1 Net mode

Function:

Network mode setting

Format:

At+netmode=<netmode>\r

Parameters:

Table 6-3 network mode

value	meaning
0	Default setup
1	Ethernet
2	Wifi client
3	Wifi ap

6.2.2 wifi_conf

Function:

Wireless parameter setting

Format:

At+wifi_conf=<ssid>, <encrypt type>, <password> \r

Parameters:

ssid: Network SSID

Encrypt type: Encryption mode

Table 6-4 Encryption mode

value	meaning
none	Open network
wep_open	Wep encryption, open authentication method
wep	Wep encryption, encryption authentication
wpa_tkip	wpa tkip
wpa_aes	wpa aes
wpa2_tkip	wpa2 tkip
wpa2_aes	wpa2 aes
wpawpa2_tkip	wpa/wpa2 tkip
wpawpa2_aes	wpa/wpa2 aes

6.2.3 Channel

Function:

WiFi wireless channel select

Format:

At+Channel=<Channel>\r

Parameter:

Channel:0-14

6.2.4 dhcp

Function:

Dhcp client enable

Format:

At+dhcp=<dhcp>\r

Parameters:

Table 6-5 Dhcp client enable

value	meaning
0	Static ip address
1	Dynamic ip address

6.2.5 net_ip

Function:

Network mode setting

This parameter is not valid when Dhcp client feature is turned on.

Format:

At+Net_ip=<ip>, <mask>, <gateway>\r

Parameters:

Ip: Ip address

Mask: Subnet mask

Gateway: Gateway Network Element

6.2.6 net_dns

Function:

Network mode setting

This parameter is not valid when Dhcp client feature is turned on

Format:

At+Net_dns=<dns1>, <dns2>\r

parameters:

dns1: Major DNS address

dns2: Minor DNS address

6.2.7 dhcpd

Function:

Dhcp server enable

This parameter is not valid when the network mode is AP.

Format:

At+dhcpd=<dhcpd>\r

Parameters:

Table 6-6 Dhcp servers enable

value	meaning
0	close
1	open

6.2.8 dhcpd_ip

Function:

Dhcp server IP setting

Format:

At+Dhcpd_ip=<ip start>, <ip end>, <mask>, <gateway>\r

parameters:

Ip start: Ip started address

Ip end: Ip ended address

Mask: Subnet mask

Gateway: Gateway Network Element

6.2.9 dhcpd_dns

Function:

Dhcp server dns setting

Format:

At+Dhcpd_dns=<dns1>, <dns2>\r

Parameters:

dns1: Major dns address

dns2: Minor dns address

6.2.10 dhcpd_time

Function:

Dhcp server time setting

Format:

At+Dhcpd_time=<time >\r

Parameters:

time: Dhcp effective time assigned to device.

6.2.11 net_commit

Function:

Submit to network setting

Network configuration parameters set to be submitted by this parameter to save the entry into

force.

Format:

At+Net_commit=< Net_commit >\r

Parameters:

Table 6-7 submit to network setting

value	meaning
0	invalid
1	submit

6.2.12 out_trans

Function:

Exit the transparent transmission mode

Format:

At+out_trans=<out_trans>\r

Parameters:

Table 6-8 Exit the transparent transmission mode

value	meaning
Arbitrarily	Exit the transparent transmission mode

6.2.13 remoteip

Function:

Remote ip or domain name setting

Format:

At+remoteip=< remoteip >\r

Parameters:

Remote server domain name or IP address

6.2.14 remoteport

Function:

Remote port setting

Format:

At+ remoteport=<remoteport>\r

Parameters:

Remoteport: Remote port

6.2.15 remotepro

Function:

Protocol Type setting

Format:

At+remotepro=<remotepro>\r

Parameters:

Table 6-9 remotepro parameters setting

value	meaning
None	No protocol
Tcp	Tcp protocol
Udp	Udp protocol

6.2.16 timeout

Function

Network time-out

Format:

At+timeout=<timeout>\r

Parameters:

Network time-out server

Network mode, when there is not any data transfer during the time-out, the connection will be disconnected. 0 specifies never disconnected.

6.2.17 mode

Function:

The conversion mode setting

Format:

At+mode=<mode>\r

Parameters:

Table 6-10 mode setting

value	meaning
None	No protocol

Client	Tcp protocol
Server	Udp protocol

6.2.18 uart

Function:

Serial configuration setting

Format:

At+uart=<baud>, <data>, <parity>, <stop>\r

parameters:

Baud: Baud rate

Data: Data bits

Parity: Parity bit

Stop: length of stop bit

6.2.19 uartpacklen

Function:

Serial framing length setting

Format:

At+uartpacklen =<uartpacklen>\r

Parameters:

uartpacklen: Serial framing length (Unit: bit) .Default value: 64.

6.2.20 uartpacktimeout

Function:

Serial framing time setting

Format:

At+ uartpacktimeout=<uartpacktimeout>\r

Parameters:

uartpacktimeout: Serial framing time (unit: ms)。 Default value:10

6.2.21 escape

Function:

Serial exiting the Pass-through enable

Format:

At+ escape=<escape>\r

Parameter:

escape: 0 - close, 1 - enable

6.2.22 tcp_auto

Function:

TCP automatic reconnection

Format:

At+ tcp_auto=<tcp_auto>\r

Parameter:

tcp_auto: 0 - close, 1 - enable.

6.2.23 save

Function:

Submitted to serial converter configuration and restart the service.

Format:

At+ save=<save>\r

Parameters:

Table 6-11 submit to network setting

value	meaning
0	invalid
1	submit

6.2.24 reconn

Function:

Restart serial transformation service

Format:

At+ reconn =< reconn >\r

Parameters:

Table 6-12 reconn

value	meaning
arbitrarily	Restart serial transformation service

6.2.25 ver

Function:

Inquiry the firmware version

Format:

At+ ver =? \r

Parameters:

None

6.3 AT command control code roution

6.3.1 Inquiry configuration information

Code:

```
char *query="\n\nat+netmode=?\r\n\nat+wifi_conf=?\r\n\nat+dhcpcd=?\r\n\nat+dhcpcd_ip=?\r\n\nat+dhcpcd_dns=?\r\n\nat+dhcpcd_time=?\r\n\nat+dhcpc=?\r\n\nat+net_ip=?\r\n\nat+net_dns=?\r\n\nat+net_wanip=?\r\n\n\nat+remoteip=?\r\n\nat+remoteport=?\r\n\nat+remotepro=?\r\n\nat+timeout=?\r\n\nat+mode=?\r\n\nat+uart=?\r\n\nat+uartpacklen=?\r\n\nat+uartpacktimeout=?\r\n\nat+ver=?\r\n\n";
```

Com_send(query);

Run,return:

```
at+netmode=? 0\nat+wifi_conf=? Hi-Link,wpa2_aes,12345678\nat+dhcpcd=? 0\nat+dhcpcd_ip=? 192.168.14.1,192.168.15.254,255.255.254.0,192.168.15.254\nat+dhcpcd_dns=? 192.168.15.254,0.0.0.0
```

```

at+dhcpcd_time=? 86400
at+dhcpc=? 1
at+net_ip=? 192.168.15.254,255.255.254.0,192.168.11.1
at+net_dns=? 192.168.11.1,0.0.0.0
at+net_wanip=? ,,
at+remoteip=? 192.168.11.245
at+remoteport=? 8080
at+remotepro=? tcp
at+timeout=? 0
at+mode=? server
at+uart=? 115200,8,n,1
at+uartpacklen=? 64
at+uartpacktimeout=? 10
at+ver=? V1.39(Dec 6 2012)

```

6.3.2 Serial to Ethernet(Dynamic ip address)

Code:

```

char *commands_eth="\
\
at+netmode=1\r\n\
at+dhcpc=1\r\n\
\
at+remoteip=192.168.11.245\r\n\
at+remoteport=8080\r\n\
at+remotepro=tcp\r\n\
at+timeout=0\r\n\
at+mode=server\r\n\
at+uart=115200,8,n,1\r\n\
at+uartpacklen=64\r\n\
at+uartpacktimeout=10\r\n\
at+net_commit=1\r\n\
at+reconn=1\r\n\
";

```

```
Com_send(commands_eth);
```

Run and return:

```

at+netmode=1 ok
at+dhcpc=1
at+remoteip=192.168.11.245 ok
at+remoteport=8080 ok
at+remotepro=tcp

```

```
at+timeout=0 ok
at+mode=server
at+uart=115200,8,n,1 ok
at+uartpacklen=64 ok
at+uartpacktimeout=10 ok
at+net_commit=1
```

6.3.3 Serial to Ethernet(static ip address)

Code:

```
char *commands_eth_static="
|
at+netmode=1\r\n|
at+dhcpc=0\r\n|
at+net_ip=192.168.11.254,255.255.255.0,192.168.11.1\r\n|
at+net_dns=192.168.11.1,8.8.8.8\r\n|
|
at+remoteip=192.168.11.245\r\n|
at+remoteport=8080\r\n|
at+remotepro=tcp\r\n|
at+timeout=0\r\n|
at+mode=server\r\n|
at+uart=115200,8,n,1\r\n|
at+uartpacklen=64\r\n|
at+uartpacktimeout=10\r\n|
at+net_commit=1\r\n|
at+reconn=1\r\n|
";
```

```
Com_send(commands_eth_static);
```

Run and return:

```
at+netmode=1 ok
at+dhcpc=0
at+net_ip=192.168.11.254,255.255.255.0,192.168.11.1 ok
at+net_dns=192.168.11.1,8.8.8.8 ok
at+remoteip=192.168.11.245 ok
at+remoteport=8080 ok
at+remotepro=tcp
at+timeout=0 ok
at+mode=server
at+uart=115200,8,n,1 ok
at+uartpacklen=64 ok
at+uartpacktimeout=10 ok
```

at+net_commit=1

6.3.4 Serial to wifi client(dynamic IP address)

Code:

```
char *commands_wifi_client="\
at+netmode=2\r\n\
at+wifi_conf=HI-LINK,wpa2_aes,12345678\r\n\
at+dhcpc=1\r\n\
\
at+remoteip=192.168.11.245\r\n\
at+remoteport=8080\r\n\
at+remotepro=tcp\r\n\
at+timeout=0\r\n\
at+mode=server\r\n\
at+uart=115200,8,n,1\r\n\
at+uartpacklen=64\r\n\
at+uartpacktimeout=10\r\n\
at+net_commit=1\r\n\
at+reconn=1\r\n\
";
```

```
Com_send(commands_wifi_client);
```

Run and return:

```
at+netmode=2 ok
at+wifi_conf=HI-LINK,wpa2_aes,12345678 ok
at+dhcpc=1
at+remoteip=192.168.11.245 ok
at+remoteport=8080 ok
at+remotepro=tcp
at+timeout=0 ok
at+mode=server
at+uart=115200,8,n,1 ok
at+uartpacklen=64 ok
at+uartpacktimeout=10 ok
at+net_commit=1
```

6.3.5 Serial to wifi client(static IP address)

Code:

```
char *commands_wifi_client_static="\
\
```

```

at+netmode=2\r\n\
at+wifi_conf=HI-LINK,wpa2_aes,12345678\r\n\
at+dhcpc=0\r\n\
at+net_ip=192.168.11.254,255.255.255.0,192.168.11.1\r\n\
at+net_dns=192.168.11.1,8.8.8.8\r\n\
\
at+remoteip=192.168.11.245\r\n\
at+remoteport=8080\r\n\
at+remotepro=tcp\r\n\
at+timeout=0\r\n\
at+mode=server\r\n\
at+uart=115200,8,n,1\r\n\
at+uartpacklen=64\r\n\
at+uartpacktimeout=10\r\n\
at+net_commit=1\r\n\
at+reconn=1\r\n\
";

```

Com_send(commands_wifi_client_static);

Run and return:

```

at+netmode=2 ok
at+wifi_conf=HI-LINK,wpa2_aes,12345678 ok
at+dhcpc=0
at+net_ip=192.168.11.254,255.255.255.0,192.168.11.1 ok
at+net_dns=192.168.11.1,8.8.8.8 ok
at+remoteip=192.168.11.245 ok
at+remoteport=8080 ok
at+remotepro=tcp
at+timeout=0 ok
at+mode=server
at+uart=115200,8,n,1 ok
at+uartpacklen=64 ok
at+uartpacktimeout=10 ok
at+net_commit=1

```

6.3.6 Serial to wifi AP

Code:

```

char *commands_wifi_ap="\
\
at+netmode=3\r\n\
at+wifi_conf=Hi-Link_,wpa2_aes,0000000000\r\n\

```

```

at+dhcpcd=1\r\n\
at+dhcpcd_ip=192.168.16.100,192.168.16.200,255.255.255.0,192.168.16.254\r\n\
at+dhcpcd_dns=192.168.16.254,8.8.8.8\r\n\
at+dhcpcd_time=86400\r\n\
at+net_ip=192.168.16.254,255.255.255.0,192.168.16.254\r\n\
at+net_dns=192.168.16.254,8.8.8.8\r\n\
\
at+remoteip=192.168.11.245\r\n\
at+remoteport=8080\r\n\
at+remoteproto=tcp\r\n\
at+timeout=0\r\n\
at+mode=server\r\n\
at+uart=115200,8,n,1\r\n\
at+uartpacklen=64\r\n\
at+uartpacktimeout=10\r\n\
at+net_commit=1\r\n\
at+reconn=1\r\n\
";

```

Com_send(commands_wifi_ap);

Run and return:

```

at+netmode=3 ok
at+wifi_conf=Hi-Link_,wpa2_aes,0000000000 ok
at+dhcpcd=1 ok
at+dhcpcd_ip=192.168.16.100,192.168.16.200,255.255.255.0,192.168.16.254 ok
at+dhcpcd_dns=192.168.16.254,8.8.8.8 ok
at+dhcpcd_time=86400 ok
at+net_ip=192.168.16.254,255.255.255.0,192.168.16.254 ok
at+net_dns=192.168.16.254,8.8.8.8 ok
at+remoteip=192.168.11.245 ok
at+remoteport=8080 ok
at+remoteproto=tcp
at+timeout=0 ok
at+mode=server
at+uart=115200,8,n,1 ok
at+uartpacklen=64 ok
at+uartpacktimeout=10 ok
at+net_commit=1

```

6.3.7 Restore factory value

Code:

```
char *commands_device_default="\
```

```
\  
at+default=1\r\n\  
at+reboot=1\r\n\  
";  
  
Com_send(commands_device_default);
```

Run and return:

```
at+default=1
```

After 30s, the modules start normally, all configuration parameters change to the factory configuration.

7 Serial configuration tools

CONFIG is a configuration tools that configurate the module through the serial port. Tool interface is as follows:

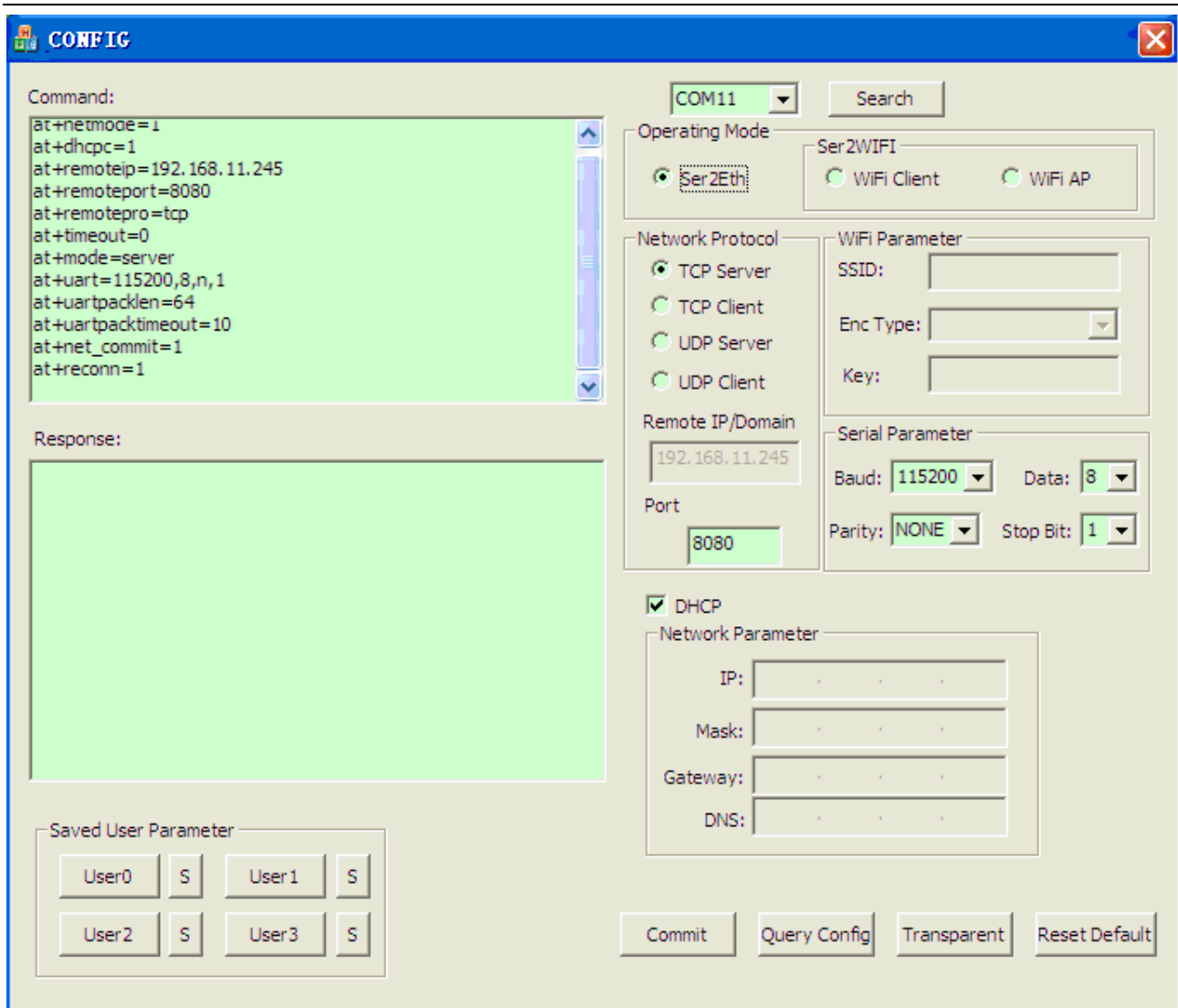

Chart 13 Configuration tools interface

Description:

1. 'Com 11' stands for configuration serial option
2. Search: module searching button
3. Operation mode: work mode selection
4. Wifi Parameter: wireless parameter configuration
5. Network Protocol: Network protocol selection
6. Serial Parameter: Serial parameter configuration
7. IP: Network IP address configuration
8. Commit: submit the configuration
9. Query config: Inquiry the configuration
10. Transparent: Access to transparent transmission mode
11. Reset Default: Restore the factory value setting

-
12. Saved User Parameter: User parameter holding area
 13. Command: Ready for sent AT instruction area
 14. Response: AT instruction return information area

7.1 Searching the Module

Through the "configure serial port choice" choose PC serial number and click on the "search module" button, the tool will use the specified serial search the module HLK - RM04, the module will be searched if it has been connected and in AT instruction mode . The module information will be found in the AT instruction return information area. Shown as below:

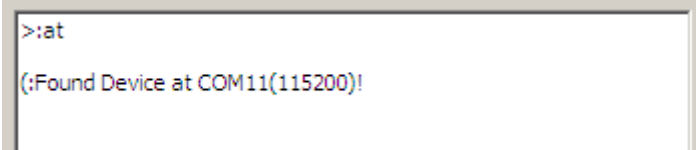

```
>:at
(:Found Device at COM11(115200)!
```

Chart 16 searching the module

At this time, The PC and module have been able to establish the normal AT command communication. All the AT interactive orders need to process based on the normal AT instruction communication.

7.2 Set each Parameters

Configure the required function through the configuration items 3, 4, 5, 6, 7. The Configuration and modification information would immediately create the matching AT command in the ready for sent AT instruction area. The generated AT instruction will not send to the module at once. Shown as below:

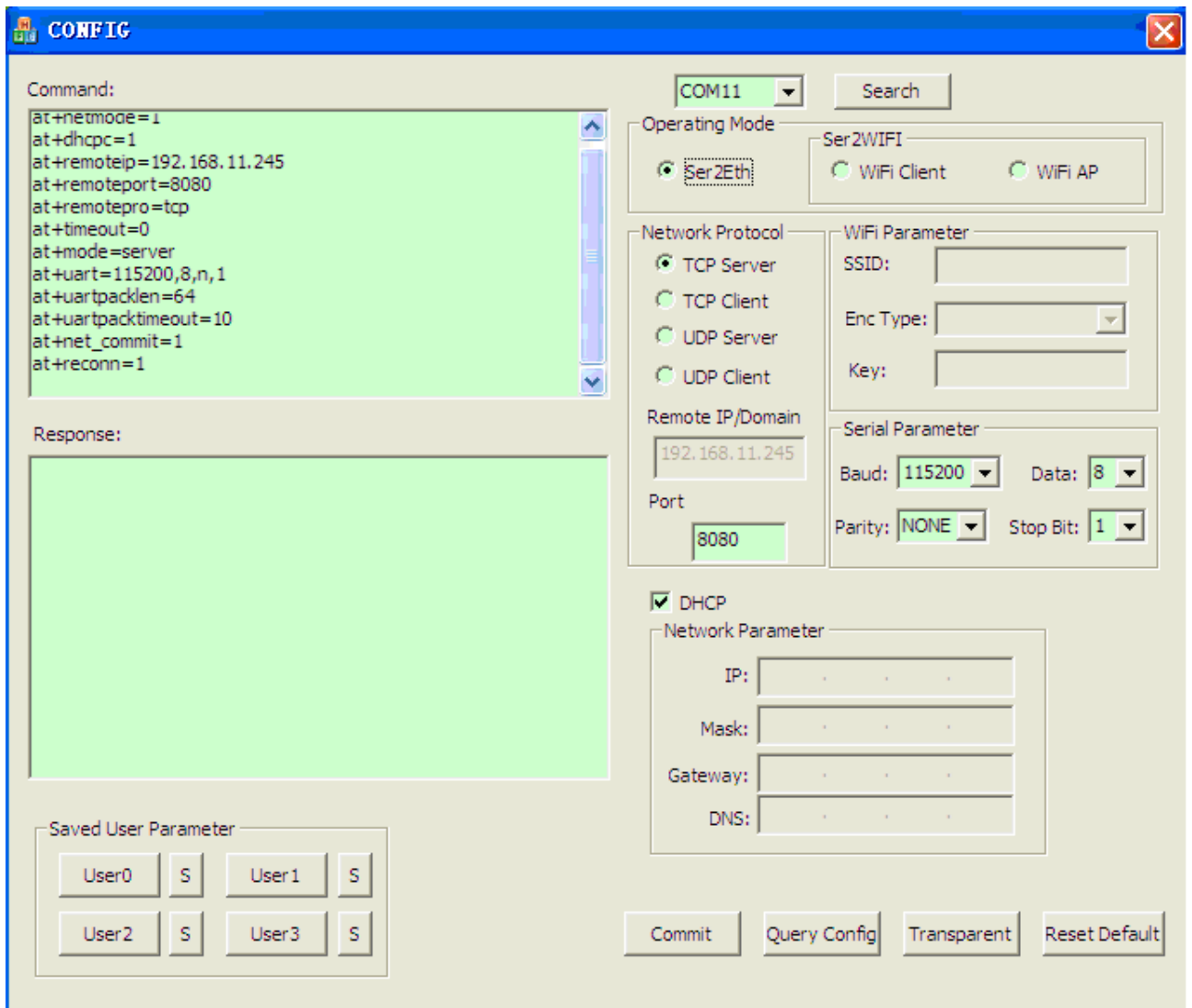

Chart 17 Serial configuration tool generates AT command

7.3 Submit the configuration

Click the submit configuration button, the tool will send the AT instruction in the ready for sent area to the module immediately. The information of command execution results will be shown in AT instruction return information area.

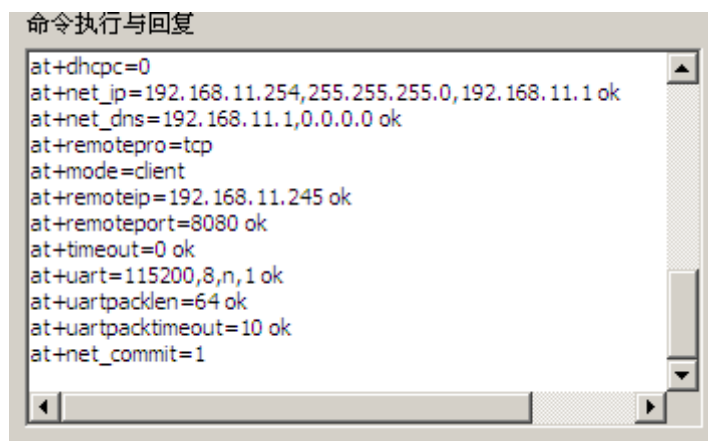

Chart18. Serial configuration tools instruction execution

7.4 User Data Retention

The user parameter holding area provides parameter saving function. Through this function you can save up four sets of parameters at most, respectively, user0 user1, user2, user3. Click "S" button, it will pop up a confirmation dialog shown as below:

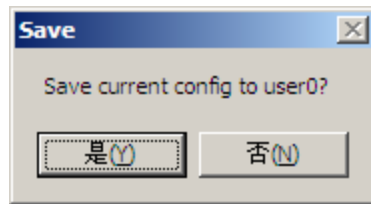

Chart 19. Pop-up Dialog of parameter saving

Click on the button "yes", the instruction in the ready for sent AT instruction area will save for user0 parameter group. After this step, when you click "user0" anytime, this parameter group can be called immediately, and covered to the ready for sent AT instruction area.

The stored user parameter will save as text file in the tools contents, file name, respectively, user0, user1, user2, user3.

7.5 Inquiry configuration

Click on the button 'inquiry', The tool will send a series of AT instructions immediately to the module to inquire the current configuration of the module, the result of execution will show in AT instruction return information area at once, each configuration items will make corresponding change with the return information.

7.6 Access to transparent transmission mode

If the module has already in the AT instruction mode, click on the button 'T/T', you can access to the transparent transmission mode at once.

7.7 Restore factory factory value setting

Click on the button 'reset', the tool will pop up a confirmed box shown as below:

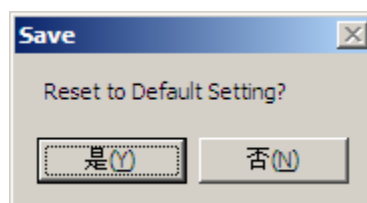

Chart 20 Pop-up box for reset default setting

Click on the button 'yes', The tools will send AT instruction immediately, after about 30 seconds, the module will access to the default state.

8 Device Search tools

Module_Discover is a search tool of network end used to search the module. The interface is as follows:

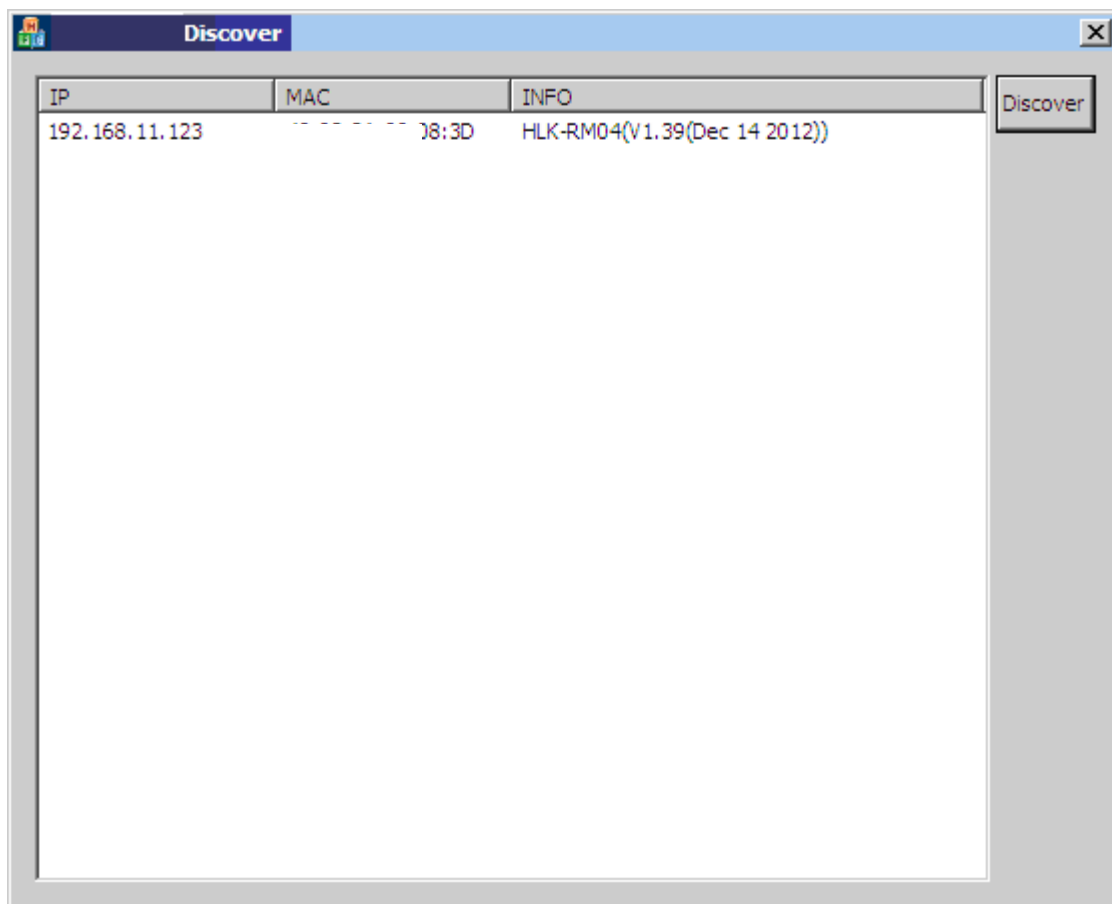

Chart 21. Device search tools

Click on the button "Discover", the tools will search all the module connected with PC in the LAN. The module being searched will show in the information box soon. The module information including: IP address, MAC address and version of it.

9 Restore factory Settings

Support the following ways to restore the factory settings

1. Through the Web page.
- 2 By keeping the ES/RST pin low level time greater than Trst.

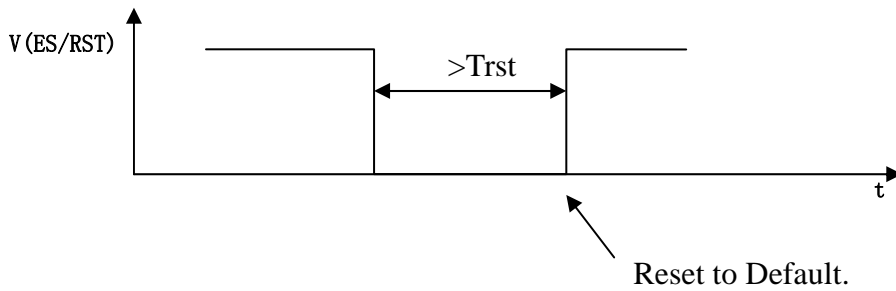

Factory setting parameter values see the following list:

netmode	0
wifi_conf	Hi-Link_,wpa2_aes,12345678
dhcpc	1
net_ip	192.168.11.254,255.255.255.0,192.168.11.1
net_dns	192.168.11.1,8.8.8.8
dhcpd	1
dhcpd_ip	192.168.16.100,192.168.16.200,255.255.255.0,192.168.16.1
dhcpd_dns	192.168.16.1,8.8.8.8
dhcpd_time	86400
remoteip	192.168.11.245
remoteport	8080
remotepro	tcp
timeout	0
mode	none
uart	115200,8,n,1
uartpacklen	64
uartpacktimeout	10
IP address	192.168.16.254
Wifi password	12345678
Web username/password	admin/admin

Tes	100ms
Trst	6s

10 Firmware upgrade

1. Restore the factory value.
2. Pc can connect with module through Ethernet, ip: 192.168.16.123/255.255.255.0. Browser visits 192.168.16.254. Username / password: admin / admin.
3. Open the following page. Select the appropriate firmware, click apply upgrades. Wait about 3 minutes. Can not cut out the upgrade process, otherwise it may cause damage to the module.



Appendix A document revision record

Version number	Revision range	Date
1.00	Draft version	2012-9-10
1.10		2012-12-1
1.20	Firmware v1.41	2013-01-14