

Robertshaw®

8625

DIGITAL
PROGRAMMABLE
THERMOSTAT**NEW**5 - 2 Day Programmable
2 Heat / 2 Cool

User's Manual

Quick Start Installation and Programming

**110-1166**

As an ENERGY STAR® partner, Invensys Controls Americas has determined that this thermostat meets the ENERGY STAR® guidelines for energy efficiency.

Application

The Robertshaw 8625 is a multi-stage thermostat designed to control 24 VAC heat pump systems.

Features

- Large backlit display.
- Four preprogrammed ENERGY STAR® setpoints for each day of the week.
- Adjustable 1st stage temperature differential: 1.0°F to 3.0°F (0.5°C to 1.5°C).
- Adjustable 2nd stage temperature differential: 1.0°F to 6.0°F (0.5°C to 3.0°C).
- Adjustable 2nd stage delay (10-40 minutes).
- Energy Efficient Recovery (EER™).
- Residual cooling for added air conditioning efficiency.
- Zone compatible as master thermostat.
- Fahrenheit/Celsius display option.
- Programmable from 45°F (4°C) to 90°F (32°C).
- Accuracy within ± 1 degree.
- Separate heating and cooling programs.

⚠ WARNING:

- Always turn off power at main fuse or circuit breaker panel before installing, removing, cleaning, or servicing thermostat.
- Read all the information in this manual before installing this thermostat.
- **DO NOT CONNECT TO 120 VAC.** This is a 24 VAC low-voltage thermostat. Do not install on voltages higher than 30 VAC.
- All wiring must conform to local and national building and electrical codes and ordinances.
- Do not short (jumper) across terminals on the gas valve or at the system control to test installation. This will damage the thermostat and void the warranty.
- Do not connect ground to any terminal in this unit.

♻ Recycling Thermostat

If this thermostat REPLACES a thermostat that contains mercury, DO NOT discard the old thermostat in the regular trash. Mercury is harmful to humans and the environment. For this reason, do not open, break, or crush the mercury cell. If mercury leaks from a damaged cell, DO NOT touch or handle mercury with bare hands. Use protective, non-absorbent gloves to place mercury into a sealable container. Fill the container with sand or another absorbent material and seal the container completely.

Return the mercury or mercury products, in a sealed container, to Invensys Controls Americas or a local recycling center for proper disposal. If you have any questions, call Robertshaw technical support at 1-800-445-8299.

Invensys Controls Americas
28C Leigh Fisher Blvd.
El Paso, TX 79906
Attn: Mercury Recycling Center

Step 1: Replacing Existing Thermostat**Wiring Table**

Old Terminal	New Label	Description
R, V-VR or VR-R	R	24VAC, return
Y, Y1, M	Y1	Compressor relay (Stage 1)
O or R	O	Reversing valve (cool active)
B	B	Reversing valve (heat active)
F or G	G	Fan control relay
Y2	Y2	2 nd stage cooling circuit
W2, W-U or E	W2/E	2 nd stage heating control or emergency heating for heat pumps
C, X or B	C	24 VAC, transformer common side
L or X	L	System monitor
W or W1	W1	1st stage heat - non heat pump

NOTE: THIS THERMOSTAT REQUIRES A 24 VAC COMMON WIRE FOR PROPER OPERATION.

NOTE: ON SOME OLDER MODELS, THE C TERMINAL CAN BE EITHER THE COOLING CONTROL OR THE COMMON SIDE OF THE TRANSFORMER. CHECK FURNACE WIRING DIAGRAM TO VERIFY C TERMINAL. IF IT IS THE COMMON SIDE OF THE TRANSFORMER, CONNECT TO THE C TERMINAL.

⚠ WARNING:

In heat pump applications, do not connect anything to the W1 terminal. When switched to HP mode, W1 is connected internally to Y1 on the thermostat. Connect AUX heat to the W2/E terminal.

1. Turn off power to heating and cooling system.
2. Remove cover of old thermostat to expose wires. Do not disconnect wires. (See Figure 1)
3. Label wires per the Wiring Table.
4. After labeling wires, remove wires from terminals.
5. Remove existing thermostat base from wall.
6. Refer to the following section for instructions on how to install thermostat.

Figure 1

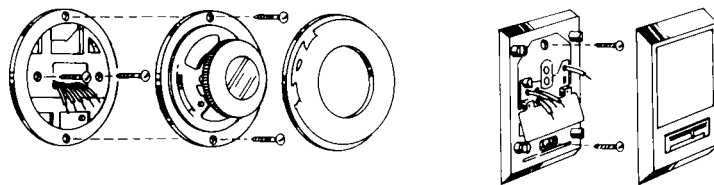

Installing Item 8625 Thermostat

NOTE: FOR NEW INSTALLATIONS, MOUNT THERMOSTAT ON AN INSIDE WALL, 4-5 FEET ABOVE THE FLOOR. DO NOT INSTALL BEHIND A DOOR, IN A CORNER, NEAR AIR VENTS, IN DIRECT SUNLIGHT, OR NEAR ANY HEAT OR STEAM GENERATING FIXTURES. INSTALLATION AT THESE PLACES WILL AFFECT THERMOSTAT OPERATION.

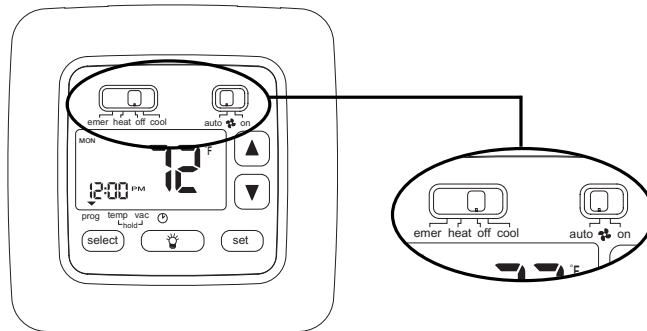

1. Turn power off to the heating and cooling systems.
2. Place EMER-HEAT-OFF-COOL in OFF position.
3. Place AUTO  ON switch into AUTO position.
4. Remove the cover using a coin or screwdriver (see Figure 2).
5. Place thermostat against the wall at desired location. Make sure wires will feed through opening on base of thermostat.

Figure 2

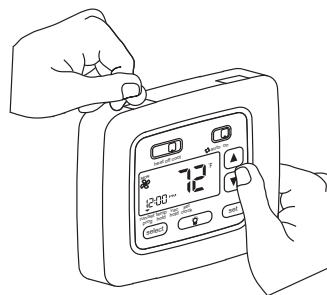
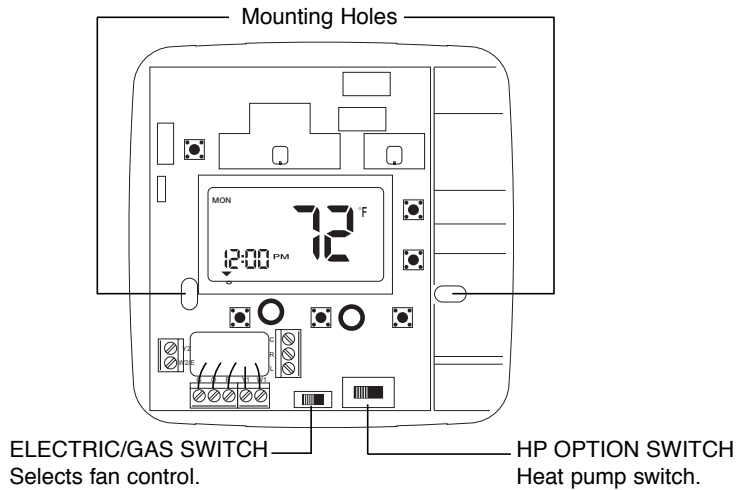

Figure 3



6. Mark placement of mounting holes (see Figure 3). Set base aside.
7. Drill the marked holes using a 3/16" (5mm) drill bit. **NOTE:** Enclosed plastic anchors do not require a drilled hole for drywall.
8. Tap plastic anchors into the wall.
9. Align base with plastic anchors and feed wires through opening (see Figure 3).
10. Secure base to wall with supplied screws.
11. Connect wires to terminal strip. Refer to wiring diagrams on page 5. Make sure wire connections are secure.
12. Place Electric/Gas switch into either the ELEC or GAS position depending on the type of furnace (see Figure 3).
13. Place the HP option switch into either the NON_HP or HP position depending on the type of system you are using (see Figure 3). Use the HP position for heat pumps **ONLY**. Use the NON_HP setting for everything else.
14. Replace cover on thermostat by snapping into place.
15. Turn on power to system. Test thermostat as described in the section **To Test Thermostat**.

Wiring Diagrams

The following is just a sample of the most common types of HVAC systems. Refer to your system's installation manual for wiring information.

**HEAT/COOL
4-WIRE
SINGLE TRANSFORMER**

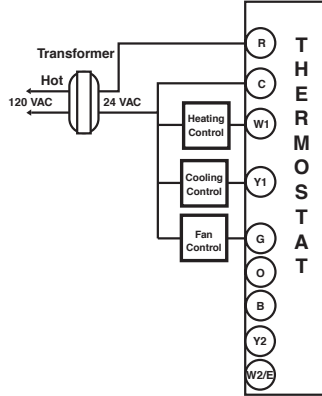

**HEAT ONLY
3-WIRE
SINGLE TRANSFORMER**

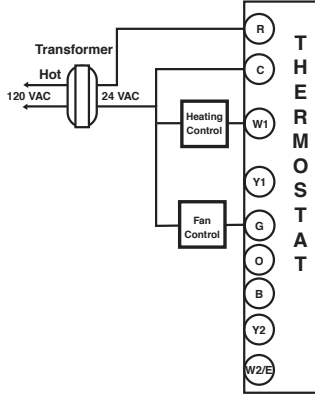

**HEAT ONLY
2-WIRE
SINGLE TRANSFORMER**

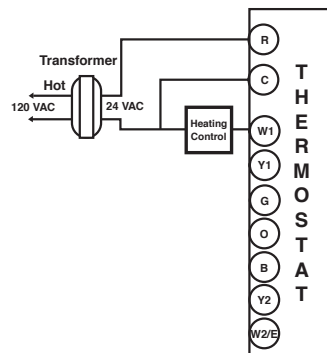

**COOL ONLY
3-WIRE
SINGLE TRANSFORMER**

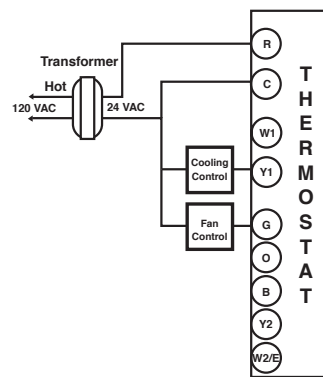

**HEAT/COOL
2 STAGE**

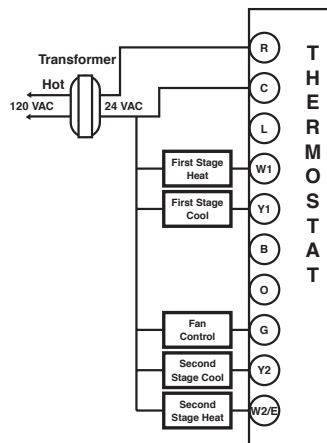

HEAT PUMP WIRING DIAGRAMS

HEAT PUMP WITH COOL ACTIVE REVERSING VALVE

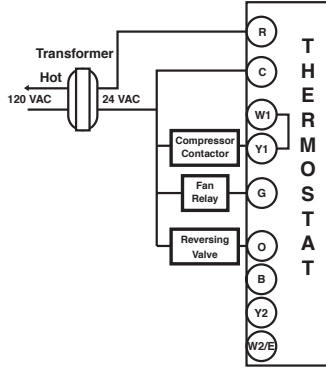

NOTE: Make sure the HP switch is in the HP position. When switched to HP mode, W1 is connected internally to Y1.

HEAT PUMP WITH HEAT ACTIVE REVERSING VALVE

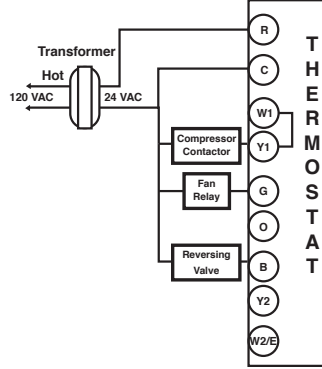

NOTE: Make sure the HP switch is in the HP position. When switched to HP mode, W1 is connected internally to Y1.

HEAT PUMP + AUX COOL COOL ACTIVE REVERSING VALVE

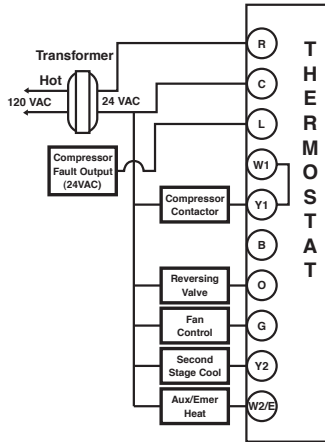

NOTE: Make sure the HP switch is in the HP position. When switched to HP mode, W1 is connected internally to Y1.

HEAT PUMP + AUX HEAT HEAT ACTIVE REVERSING VALVE

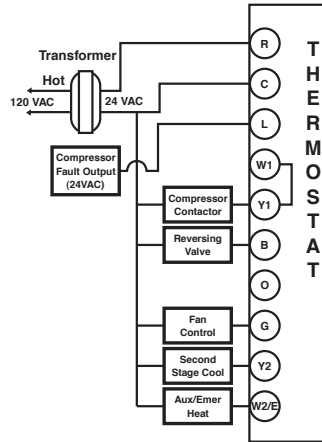

NOTE: Make sure the HP switch is in the HP position. When switched to HP mode, W1 is connected internally to Y1.

To Test Thermostat

⚠ WARNING: DO NOT SHORT (JUMPER) ACROSS TERMINALS OF GAS VALVE OR SYSTEM CONTROL TO TEST OPERATION. THIS WILL DAMAGE THE THERMOSTAT AND VOID YOUR WARRANTY.

CAUTION: DO NOT SWITCH SYSTEM TO COOL OR LEAVE IN COOL MODE IF THE TEMPERATURE IS BELOW 50°F (10°C). THIS CAN DAMAGE THE AIR CONDITIONING SYSTEM AND CAUSE PERSONAL INJURY.

1. Place the EMER-HEAT-OFF-COOL switch into the COOL position. The * will be displayed.
2. Press the ▼ button until the temperature setting is at least 3 degrees below the room temperature. The air conditioning system should turn on within a few seconds.

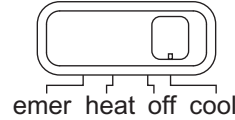

NOTE: ONCE THE THERMOSTAT TURNS OFF WHEN IN THE COOL MODE, A BUILT IN 5-MINUTE DELAY PREVENTS THE SYSTEM FROM TURNING ON AGAIN. THIS PROTECTS THE COMPRESSOR. NO ADDITIONAL TIME DELAY RELAY IS REQUIRED. TO OVERRIDE THE 5-MINUTE DELAY FOR INSTALLATION, PRESS THE RESET BUTTON.

3. Put the EMER-HEAT-OFF-COOL switch into the OFF position. The air conditioning system should turn off.

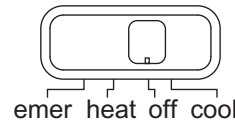

4. Put the EMER-HEAT-OFF-COOL switch into the HEAT position. The ♂ will be displayed.
5. Press the ▲ button until the temperature setting is at least 3 degrees above room temperature. The heating system should turn on. The fan may not turn on immediately, depending on the fan delay built into the furnace.

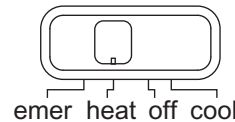

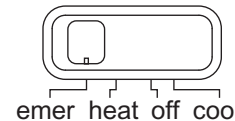

NOTE: If HP is selected, the heat will not come on until the 5 minute short cycle protection has expired.

6. Put the EMER-HEAT-OFF-COOL switch into the EMER position. The ♂^e will be displayed.
7. Press the ▲ button until the temperature setting is at least 3 degrees above room temperature. The secondary heating system should turn on.

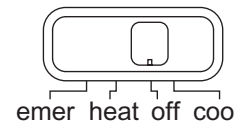

- NOTE: The compressor will not turn when in emergency heat mode.**
8. Put the EMER-HEAT-OFF-COOL switch into the OFF position. The heating system should turn off. The fan may continue to run for a short period of time.



9. Put the AUTO  ON switch into the ON position. The blower fan should turn on. The display will show a .



10. Put the AUTO  ON switch into the AUTO position. The blower fan should turn off.



Programming Guide

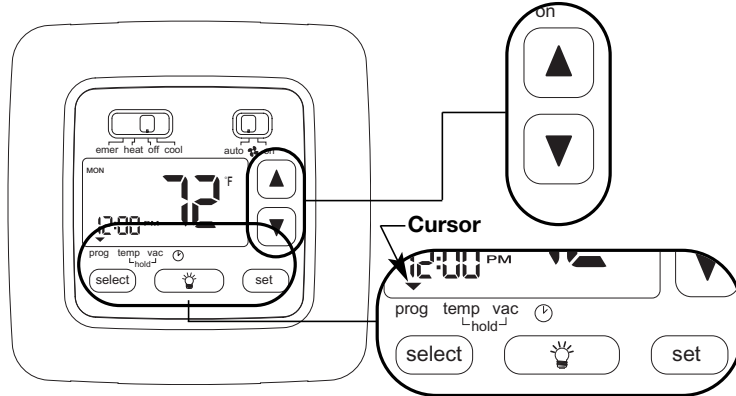

SETTING TIME OF DAY AND DAY OF WEEK

1. Press SELECT until the cursor is over ☉. Press SET. The HOURS segment will be blinking. Use the ▲ or ▼ button to adjust the HOURS setting. **NOTE:** The **AM** or **PM** indicator will change as the HOURS display rolls through a 24 hour cycle.
2. Press SET. The MINUTES segment will be blinking. Use the ▲ or ▼ button to adjust the MINUTES setting.
3. Press SET. The DAY segment will be blinking at the top of the display. Use the ▲ or ▼ button to adjust the day of the week. Press SET.

MON	=	MONDAY
TUE	=	TUESDAY
WED	=	WEDNESDAY
THU	=	THURSDAY
FRI	=	FRIDAY
SAT	=	SATURDAY
SUN	=	SUNDAY

PROGRAMMING YOUR THERMOSTAT

The 8625 thermostat features 1-button programming. Simply follow these steps to customize your thermostat for your lifestyle.

1. Place the HEAT-OFF-COOL switch into the HEAT position. Make sure the cursor is in the PROG position. Press SET. The HOURS segment will be blinking. **MON** thru **FRI** (the work week) will be displayed across the top. **AM1** will be illuminated in the lower right hand corner. You can now start programming the first event of the work week.
2. Use the ▲ or ▼ button to adjust the hour of the first event. Press SET.
3. The MINUTES segment will be blinking. Use the ▲ or ▼ button to adjust the minutes. Press SET.
4. The temperature should be blinking. Use the ▲ or ▼ button to adjust the desired temperature of the first event. Press SET.
5. **AM2** should now be displayed. Repeat steps 2-4 to program the remaining events (**PM1** and **PM2**) for the work week. There are a total of 4 events.

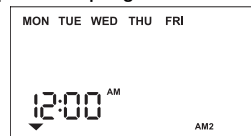

6. After pressing SET for the 4th event, the day of the week along the top will switch to **SAT SUN** and **AM1** will be displayed. Repeat steps 2-4 to program the weekend settings.



7. With the weekend settings programmed, place the HEAT-OFF-COOL switch in the COOL position. Repeat steps 2-6 to program the cooling settings.

CUSTOMIZING THE THERMOSTAT

Settings

System

Cool: The thermostat controls the cooling.

Off: The heating and cooling systems are off.

Heat: The thermostat controls the heat.

Emer: The thermostat controls the second stage emergency heat. Use only when the primary stage of heat is not functioning or requires service. The display will show **CHECK HP** when the heat pump requires service.

Fan

Auto: Equipment controls the fan.

On: The fan operates continuously.



Temperature Differential

The temperature differential for 1st stage is factory set at 1.0°F (.5°C). This means that whenever the room temperature changes by one degree Fahrenheit from the temperature setting, the system will turn on. If the system turns on too often, increase the temperature differential.

NOTE: The temperature differential for 2nd stage is factory set at 2.0°F (1.0°C)

Changing Fahrenheit (°F) to Celsius (°C), Clock Setting, Temperature Differential, and Filter Monitor

- The thermostat is preset to display the temperature in degrees Fahrenheit (US models) or degrees Celsius (Canadian models). The temperature display can be changed. Press and hold both the SELECT and SET buttons for three seconds. The display will flash either an **F** or **C**. Release buttons. Press the ▲ or ▼ button to switch the display.
- Press SET. The display will switch to the clock setting.
- The display will read **CLOC**. Use the ▲ or ▼ button to toggle between 12 or 24 for the clock setting.
- Press SET. The display will switch to the differential setting for 1st stage heating and cooling.
- The display will read **diFF**. Press the ▲ or ▼ button to adjust the differential up or down.



6. Press SET. The display will switch to the differential setting for 2nd stage heating and cooling.
7. The display will read **diF2**. Press the ▲ or ▼ button to adjust the differential up or down.
8. Press SET. The display will switch to the differential delay.
9. The display will read **dLY2**. The differential delay is the length of time (in minutes) from when the 1st stage engages, until the 2nd stage engages to assist in heating or cooling. Press the ▲ or ▼ button to adjust the delay up or down.
10. Press SET. The display will switch to the Energy Efficient Recovery (EER™) setting.
11. The display will read **EER**. When turned on, the thermostat will look ahead to determine when to turn on the heating/cooling system in order to reach the desired temperature at the desired time. Press the ▲ or ▼ button to turn EER on or off.
12. Press SET. The display will switch to the filter monitor setting.
13. **CHECK FILTER** and the length of hours for the filter monitor will be displayed.
14. Use the ▲ or ▼ to adjust the filter timer from 0 (OFF) to 9900 hours. **NOTE:** The filter timer is based on equipment run time. Select the length of time based on the recommended service interval for your filter.
15. Press SET to return to normal operation.

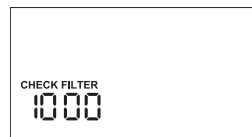

Begin Programmed Operation

1. Make sure the cursor is above PROG.
2. Place AUTO  ON switch into AUTO.
3. Place HEAT-OFF-COOL switch into COOL or HEAT depending on the season.

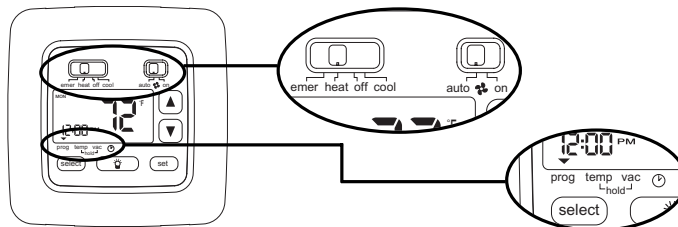

Temporary Program Hold

You can temporarily increase or decrease the temperature and hold it for 3 hours or until the next program event, whichever comes first.

1. Press the ▲ or ▼ button. The temperature will blink. Using the ▲ ▼ or button, adjust the temperature to the desired level.
2. Press SET.

Another way to select a temporary hold is:

1. Press SELECT until the cursor is over TEMP HOLD. Press SET. The temperature will be blinking. Use the ▲ or ▼ button to change the temperature.
2. Press SET.

To cancel a temporary hold, press SELECT until the cursor is above PROG. Press SET.

Vacation Hold

You can set your thermostat to hold a desired temperature for 1-365 days. Vacation hold terminates at midnight of the last day. The thermostat returns to normal operation the next day at 12:01 AM.

1. Press SELECT until the cursor is over VAC HOLD. Press SET. The temperature will be blinking. Use the ▲ or ▼ button to change the temperature.
2. Press SET. **365d** will be displayed. Use the ▲ or ▼ button to adjust between 1 and 365 days.
3. Press SET.

To cancel a vacation hold, press SELECT until the cursor is above PROG. Press SET.

Check Filter Reset

Once the filter timer has expired, **CHECK FILTER** will turn on and stay on. To clear the message and reset the timer:

1. Press SELECT and SET and hold for 3 seconds. **CLr** will appear in the time display.
2. Press any key to clear the message. The display will transition to the temperature scale display. See step 4 in **CUSTOMIZING YOUR THERMOSTAT**.
3. No further input is needed. Within a few seconds, the display will return to the normal operating mode.



Backlit Display

This thermostat is equipped with a backlight to make night time temperature adjustments quick and easy. Press the  button to activate the backlight. The backlight will turn off after about 10 seconds of inactivity.

Reset

The RESET button is located above the upper left corner of the display. Only use the reset feature if the thermostat is malfunctioning.

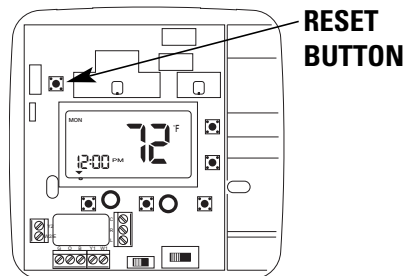

Troubleshooting

Symptom	Remedy
Thermostat does not turn on system.	Check wiring. (See Installing Item 8625 Thermostat)
Thermostat turns on and off too frequently.	Increase temperature differential. (See Programming Guide)
System fan does not operate properly.	Move the Electric/Gas switch to either gas or electric, to match system. (See Installing Item 8625 Thermostat)
Time shown on display is not the current time of day.	Change time of day setting. (See Programming Guide)
Thermostat does not follow program.	Thermostat may not have been programmed in HEAT or COOL position. Verify program. Check AM/PM indicators at time of day and programmed time changes. (See Programming Guide) Verify program and day of week are correct. (See Programming Guide)

If problems with thermostat cannot be resolved, call:

Technical Support: (800) 445-8299

Monday-Friday 7:30-5:30 CST

For after hours service, a 24-hour automated help line is available.

TWO-YEAR LIMITED WARRANTY

Invensys Controls Americas warrants to the original contractor installer or to the original consumer user, each new Robertshaw thermostat to be free from defects in materials and workmanship under normal use and service for a period of two (2) years from date of purchase. This warranty and our liability does not apply to batteries or merchandise that has been damaged by misuse, neglect, mishandling, alterations, improper installation, or use in a way other than in accordance with **Invensys Controls Americas** recommendations and instructions.

Invensys Controls Americas agrees to repair or replace at its option any thermostat under warranty provided it is returned within the warranty period, postage prepaid, with proof of the date of purchase. Cost of thermostat removal or reinstallation is not the responsibility of **Invensys Controls Americas**.

Repair or replacement as provided under this warranty is the exclusive remedy of the consumer. **Invensys Controls Americas** shall not be liable for any incidental or consequential damages for breach of any express or implied warranty on this product, or under any other theory of liability. Except to the extent prohibited by applicable law, any implied warranty of merchantability or fitness for a particular purpose on this product is limited to the duration of this warranty.

Some states do not allow the exclusion or limitation of incidental or consequential damages, or allow limitations on how long an implied warranty lasts, so the above limitations or exclusions may not apply to you. This warranty gives you specific legal rights, and you may also have other rights which vary from state to state.

For warranty returns, send thermostat, shipping prepaid to:

Invensys Controls Americas
Warranty Department
515 South Promenade Avenue
Corona, CA 92879-1736

Invensys. Controls Americas
191 E. North Avenue
Carol Stream, Illinois 60188
United States of America

Notes

