

Your Guarantee

If this product is found to be faulty as a result of faulty materials or workmanship within one year from date of purchase, it will be repaired free of charge.

This guarantee is subject to the following terms:

- Sunpentown must be notified of the fault.
- Proof of purchase must be presented to Sunpentown's nominated representative.
- The warranty will be void if the product is modified, misused or repaired by an unauthorized person.
- The warranty after repair will not be extended beyond the original one-year period.
- All replacement parts will be new or reconditioned.
- Parts, which are replaced, become the property of Sunpentown.
- The warranty applies for the use of the product in the USA only.

What is NOT COVERED:

- Warranty does not include freight charges.
- Incidental or consequential damage caused by possible defects with this product.
- Damage to product caused by improper power supply voltage, accident, fire, floods or acts of nature.
- Failure of product resulting from unauthorized modifications to the product.
- Improper installation or failure to perform the necessary maintenance.

This GUARANTEE is in addition to your Statutory Rights

SUNPENTOWN INTERNATIONAL INC.
14625 Clark Ave. City of Industry, CA 91745
Tel: 800-330-0388
service@sunpentown.com
www.sunpentown.com

Mr. Induction[®]

SMARTSCAN[®]

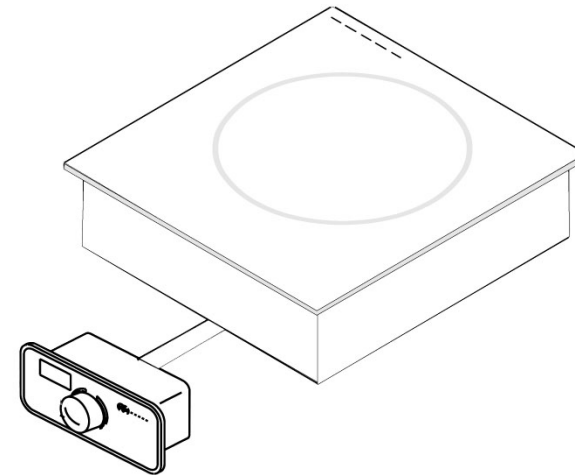

SR-182R (120V / 1800W)

SR-343R (208-240V / 3400W)

INSTRUCTION MANUAL



Thank you for purchasing your SMARTSCAN induction cooker by Sunpentown. Make full use of your new induction range. Please carefully read this manual and keep on hand for future reference.

IMPORTANT SAFEGUARDS

- A. Read all instructions.
- B. Do not touch hot surfaces. Use handles or knobs.
- C. To protect against electrical shock, do not immerse cord or appliance in water or other liquid.
- D. Close supervision is necessary when any appliance is used by or near children.
- E. Unplug from outlet when not in use and before cleaning. Allow to cool before putting on or taking off parts.
- F. Do not operate any appliance with a damaged cord or plug or after the appliance malfunctions or has been damaged in any manner. Return appliance to the nearest authorized service facility for examination, repair or adjustment.
- G. The use of accessory attachments not recommended by the appliance manufacturer may cause injuries.
- H. Do not use outdoors.
- I. Do not let cord hang over edge of table or counter, or touch hot surfaces.
- J. Do not place on or near a hot gas or electric burner, or in a heated oven.
- K. Extreme caution must be used when moving an appliance containing hot oil or other hot liquids.
- L. Always attach plug to appliance first, then plug cord into the wall outlet. To disconnect, turn any control to “off”, then removed plug from wall outlet.
- M. Do not use appliance for other than intended use.
- N. Save these instructions.

SPECIFICATIONS

Model	SR-182R	SR-343R
Voltage	120V~ / 60Hz	208-240V / 50Hz
Consumption	1800W	3400W
Dimension	12.60" x 13.4" x 3.94" (H)	
Weight	12.79 LBS	
Power Range	350~1800W	2000~3400W
Cord Length	5.9 feet	
Protection Designs	Overheat protection. Automatic hazard detection. Circuit protection sensor. High voltage. 20A fuse. Small object heat prevention. Thermostat. Pan material detection	

TROUBLESHOOTING

INDEX

PROBLEM	CHECK POINTS
No power or cooktop does not read the command	<ul style="list-style-type: none"> ▪ Is the cooktop plugged firmly into a correct outlet? ▪ Does the cooktop have a dedicated 15-amp line? The cooktop needs 13 amps to operate and should be on a 15-amp dedicated circuit. If the circuit is not 15-amps or if there are other electrical draws on the circuit, the unit is not getting enough power. ▪ Has the unit been dropped or handled roughly? If so, we suggest sending it in for evaluation. ▪ Are the buttons broken? ▪ Was there a power shortage in the building?
Cook / Temp indicator continues to flash even with a pan on the unit and the unit does not heat up	<ul style="list-style-type: none"> ▪ Is the pan an induction compatible pan? These symptoms suggest the cooktop is not sensing a pan. ▪ The pan may be too small or too large for the electromagnetic field. The pan should be no smaller than 4.5" or larger than 12". ▪ Is the pan centered in the electromagnetic field?
Cooktop suddenly stops heating during normal operation	<ul style="list-style-type: none"> ▪ There may have been a power shortage (blow out) at the facility where the unit is being used and starving the unit of power. This may also occur if you are not using a 15-amp dedicated line. ▪ Has another electrical appliance begun to draw from the same circuit therefore starving the cooktop of power? ▪ Check the fan to see if it is still running. ▪ Are the air vents blocked? The vents can be blocked on the outside by a wall or something similar OR on the inside by dust, grease and food residue. The unit must have a 2" clearance for air circulation around the sides and back. Otherwise, the internal temperature will become too high. The unit has a Safety Shut-Off, which lasts for 15-20 minutes before returning to full power. If it is necessary to leave an empty pan on the unit, the power must be set below 300 watts. ▪ Was the unit on cook mode for more than 2 hours but with no settings changed?
Pan does not get hot enough even though temperature is set on high	<ul style="list-style-type: none"> ▪ Check if the "TEMP" button is on, which means the cooktop will generate no more than 1100watts of power. If so, switch to COOK. ▪ Are you using an extension cord? Any use of an extension cord over 10 feet will affect the power reaching cooktop.
Pan cooks unevenly or does not maintain heat level and overheats	<ul style="list-style-type: none"> ▪ Is it an induction compatible pan? ▪ Pan may be the wrong shape (too convex/concave) or the wrong size (smaller than 4.5" or larger than 12"). ▪ Pan may not be centered on the cooktop.
Fan continues to run when the unit is turned off	<ul style="list-style-type: none"> ▪ The fan will continue to run until unit is completely cooled down. This is a safety feature. It is designed to help preserve the life of the cooktop.

Page 1 – Important Safeguards

Page 2 – Index

Page 3 – Installation Knob

Page 4 – Installation

Page 5 – How to Use

Page 6 – Key Points Before Using the Cooktop

Page 7 – List of Suitable & Unsuitable Cookware

Page 9 – Troubleshooting

Page 10 – Specifications

Control Plate (SR-182R)

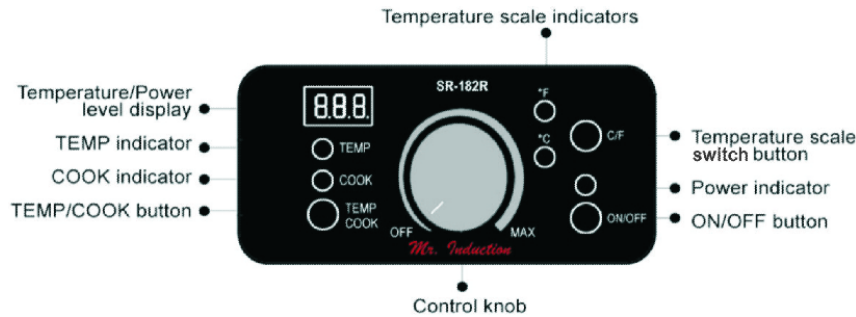

Installation

- The cooktop can be surface-mounted into the countertop.
- The cooktop can be flush with the countertop

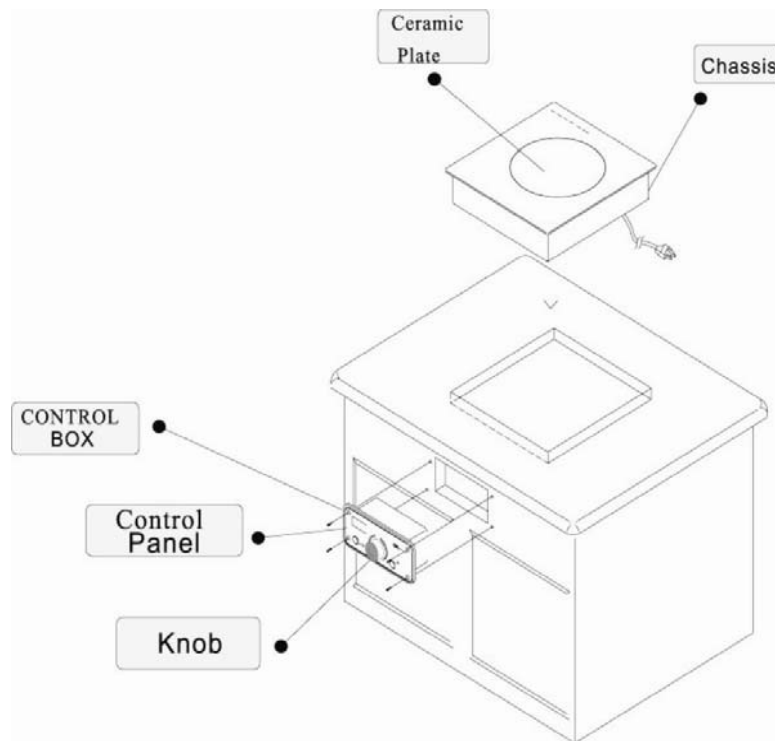

Unsuitable Cookware

Ceramic, GLASS, copper, bronze, aluminum bottom, or bottom of less than 12cm(4.5in) cookware.



Copper, bronze and aluminum cookware



Glass cookware



Ceramic cookware (without special coating)

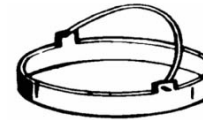

Pans with legs or with a concave bottom



Bowl-shaped cookware



Cookware with diameter less than 12cm(4.5in)

Maintaining the product

- Unplug the cord before any cleaning is done.
- To clean the ceramic plate, use a soft sponge with dishwashing liquid. Then wipe clean with damp towel.
- Clean fan intake with vacuum whenever necessary.

DO NOT IMMERSE THE COOKTOP IN WATER TO SOAK. THIS WILL DAMAGE THE COOKTOP.

NOTE

This equipment generates, uses and can radiate radio frequency energy and, if not installed and used in accordance with the instructions, may cause harmful interference to radio communications. However, there is no guarantee that interference will not occur in a particular installation. If this equipment does cause harm to radio or television reception, which can be determined by turning the equipment off and on, the user is encouraged to try to correct the interference by one or more of the following measures:

- Reorient or relocate the receiving antenna.
- Increase the separation between the equipment and receiver.
- Connect equipment to an outlet that's on a different circuit than the receiver.
- Consult the dealer or an experienced radio/TV technician for help.

Changes or modifications not expressly approved by the party responsible for compliance could void the user's authority to operate the equipment.

- Please plug this cooktop in the correct 15-amp outlet.
- Do not share the outlet with other appliances and make sure it is correctly plugged in.
- Do not touch the ceramic plate immediately after cooking, the plate may remain hot due to heat transferred from the cookware.
- Do not insert any object in the inlet or outlet to prevent electric shock.
- Do not damage the ceramic plate.
- If the ceramic plate is broken, please turn unit off and unplug from outlet immediately.

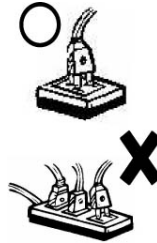

IMPORTANT:

- If the electric cord is damaged, please contact our service technician for a replacement.
- This appliance is equipped with overheat protection feature.
- Those with a pacemaker should consult their physician before using this item.
- If the cooktop surface is broken or cracked, do not use the product as it may cause electric shock.







EMERGENCY PROCEDURES

If the cooktop is not working properly, please contact our service technician for assistance. Do not disassemble the unit by yourself.

LIST OF SUITABLE / UNSUITABLE COOKWARE

Suitable Cookware

Iron, cast iron, stainless steel and enameled wares with diameter over 12cm(4.5in) are recommended.

 S/S Multi-ply Cookware	 Iron/Steel Fry pan	 Cast Iron pot
 Iron pan	 Iron/Steel Tray	 Enameled ware

INSTALLATION

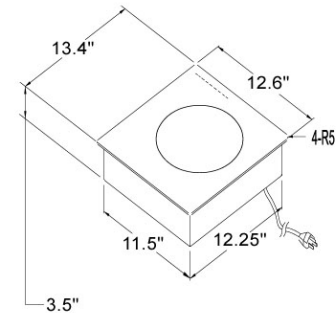
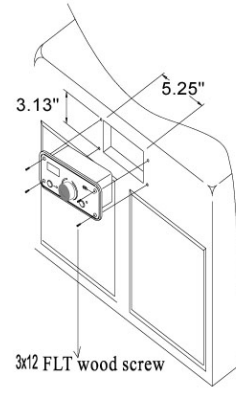

Install in kitchen counter. Unit : inch.

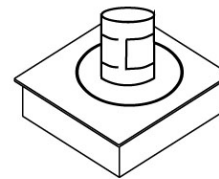

Do not place any other articles on the cooktop plate except proper cookware.

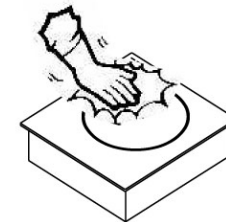

Do not touch the ceramic plate after cooking. As surface may retain heat from cookware.

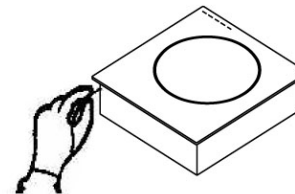

Do not insert wire screwdriver or other metal parts into vent hole.

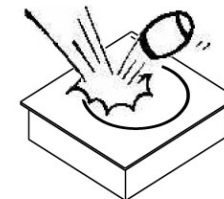

Do not damage the ceramic plate. If the ceramic plate is broken, please turn off the unit and unplug from outlet immediately.

COOK vs TEMP

The operation of this induction cooktop has two functions: COOK and TEMP.

In <COOK> Function (COOK indicator is on):

- LED displays a one or two digit number, indicating the power level (1-20)
- Unit will continuously cook until: manually shut off.

In <TEMP> Function (TEMP indicator is on):

- LED displays a two or three digit number, indicating cooking temperature. (90°F/32°C, 110°F/43°C, 130°F/54°C, 150°F/65°C, 170°F/76°C, 180°F/82°C, 200°F/93°C, 220°F/104°C, 240°F/115°C, 260°F/126°C, 270°F/132°C, 290°F/143°C, 310°F/154°C, 330°F/165°C, 350°F/176°C, 360°F/182°C, 380°F/193°C, 400°F/204°C, 420°F/215°C, 440°F/226°C)
- Unit will cook until set temperature is reached and will keep warm.
- When set temperature is reached, unit will stop heating. Unit starts heating again when it senses temperature has dropped below setting.
- Temperature difference: when cooking a large pot of soup or other contents, please be advised that the temperature inside the pot will vary from point to point. For example, the bottom section (closest to cooktop) will be a bit hotter than the middle section. The type and quality of cookware can affect temperature transfer.

HOW TO USE

1. Plug in power cord (120V / 60Hz) - unit will beep once.
2. Please suitable cookware and add food contents.
3. Press ON/OFF button (red indicator light will illuminate) AND turn knob clockwise until it “clicks” to turn on unit.
4. Press COOK/TEMP button to select setting
 - COOK mode: LED displays power level: 1~20
 - TEMP mode: LED displays temperature: 90~440°F / 32~226°C
5. Turn knob clockwise/counter-clockwise to set power level or temperature.
6. When cooking is done, turn unit off by pressing ON/OFF button or turn knob all the way left till “click” is heard.

NOTE:

- You must press ON/OFF button AND turn knob clockwise, pass click to turn on unit. Pressing the ON/OFF button OR turn knob counter-clockwise to OFF position will turn unit off.
- Safety feature: if no cookware is placed, unit will shut off after 2 minutes.
- To avoid temperature jump, please cook at least 1 quart of food/content.
- Actual temperature (in TEMP mode) may vary slightly due to different variables, such as: surrounding temperature, content and volume of food, and if using a lid, etc.
- Use flat cookware and place in center of plate.
- When using cookware that is not flat or with an uneven bottom, the set temperature will be VERY different from the actual temperature.

ATTENTION

- Always place cookware or other objects on the top plate gently as the ceramic plate may crack under force.
- Please use suitable cookware, otherwise abnormal cooking or damage may occur.
- The self-protect circuit will protect the unit when power supply is unstable. The red power light will be flashing and cooking will stop.

KEY POINTS BEFORE USING THE COOKTOP