

# NeTYS PL 550-750 VA

## PRODUCT MANUAL

### CONTENTS

<b>1. SAFETY STANDARDS .....</b>	<b>4</b>
<b>2. GENERAL DESCRIPTION.....</b>	<b>5</b>
2.1. LED-BASED CONTROL AND DISPLAY PANEL .....	6
<b>3. UNPACKING AND INSTALLATION.....</b>	<b>7</b>
3.1. UNPACKING.....	7
3.2. ENVIRONMENTAL REQUIREMENTS FOR INSTALLATION .....	7
3.3. CONNECTION TO THE MAINS POWER SUPPLY AND CONNECTING THE LOAD.....	7
<b>4. OPERATING MODES .....</b>	<b>8</b>
<b>5. COMMUNICATION .....</b>	<b>9</b>
<b>6. MAINTENANCE .....</b>	<b>10</b>
6.1. REMEDIES FOR MINOR PROBLEMS.....	10
<b>7. TECHNICAL DATA .....</b>	<b>11</b>

## CERTIFICATE AND CONDITIONS OF WARRANTY

**This SOCOMEC UPS uninterruptible power system is guaranteed against manufacturing and material defects, for a period of 24 months** from the date of purchase and not however more than 27 months from the date of shipment by SOCOMEC UPS..

The warranty is of the 'carry-in' type: free supply of parts and labour for repairs, with return of a product to be replaced to SOCOMEC UPS, or authorized centres, at the customer's cost and risk.

**In order to use the warranty service, the user must respect the following rules:**

- the product must be returned exclusively in its original packaging. Any damage caused during shipping in packaging other than the original is not covered by the warranty;
- the product must be accompanied by proof of purchase: a document (bill, invoice, receipt) showing the date of purchase and the information necessary to identify the product (model, serial number). The number of the authorization for return for repairs must also be attached, with a detailed description of the defect found in the product. If any of these elements is missing, the warranty is invalid. The return authorization number is issued by the service centres by telephone on receiving notification of the malfunction;

The warranty is recognised within Italian territory. If the UPS is exported outside Italian territory, the warranty shall be limited to the cover of the parts used to repair the fault.

**The warranty shall not apply in the following cases:**

- Failures due to fortuitous circumstances or force majeure (lightning, floods, etc.);
- Failures due to negligence or improper use (use outside tolerance limits: temperature, humidity, ventilation, electric power supply, applied load, batteries);
- Insufficient or inadequate maintenance;
- Attempted maintenance, repairs or modifications not carried out by SOCOMEC UPS personnel or personnel from a support centre authorised by SOCOMEC UPS.
- If the battery has not been recharged in accordance with the terms indicated on the packaging and in the manual, in cases of extended storage or UPS inactivity.

SOCOMECS UPS may, at its own discretion, opt for the repair of the product or for the replacement of the faulty or defective parts with new parts or with used parts that are equivalent to new parts with regard to functions and performance.

Defective or faulty parts replaced free of charge are to be put at the disposal of SOCOMEC UPS that becomes the sole owner.

Replacements or repairs of parts and any modifications to the product during the warranty period shall not extend the duration of the warranty.

In no case will SOCOMEC UPS be responsible for damages (including, without limitations, damage for loss of earnings, interruption of activity, loss of information or other economic losses) deriving from the use of the product.

The present conditions are subject to Italian law. Any dispute falls under the province of the Court of Vicenza.

\* For further information: [www.socomec.com](http://www.socomec.com)

## 1. SAFETY STANDARDS

---

This manual must be kept next to the UPS, so that the operator may consult it at any time for clarification on the correct use of the UPS.

Read the manual carefully before connecting the unit to the mains power supply and to the devices to be powered.

Before switching on the UPS (*Uninterruptible Power Supply*), the operator must be fully aware of the functions and positions of all the controls and of the technical and functional characteristics of the system, in order to avoid any risk to persons and to the equipment.

- Before starting, the unit must have an equipotential connection as established by the safety standards in force. The earth cable of the UPS must be connected to an efficient earth point.
- If the unit is not earthed, all devices connected to the UPS will not have an equipotential connection. In this case the manufacturer declines all responsibility for damage or accidents caused by non-observance of the aforementioned standards.
- This is pluggable type A equipment with battery already installed by the supplier, it's operator installable and may be operated by layman.
- In case of power failure (UPS in back up mode), do not disconnect the input cable from the mains so as to ensure earth connection to the powered loads.
- All subsequent maintenance operations must be carried out solely and exclusively by authorized personnel. Inside the system high electric voltages are generated which may endanger maintenance personnel who are not sufficiently prepared and trained for such tasks.
- If at any time a hazard condition is created during use, disconnect the mains power supply (if possible through the control panel upstream of the unit) and shutdown the UPS completely following the appropriate procedure.
- When assembling and replacing the battery, the UPS should always be switched off and disconnected from the mains power supply. Do not dispose of batteries in a fire, the battery may explode.
- CAUTION : a battery can present a risk of electric shock and high short circuit current. The following precaution should be observed when working on batteries: remove watches, rings or other metal objects and use tools with insulated handles.
- The batteries constitute an internal power source for the UPS and mean that the system output may be powered even when the UPS is not connected to the mains power supply.
- Do not force, break or try to open the batteries. They are sealed and do not require any maintenance. They contain substances that are toxic to health and that pollute the atmosphere. Do not switch the UPS on if any leakage of liquid or white powder residue is noted.
- Replace batteries with the same number and type of batteries as originally installed in the equipment.
- Replace the fuses ONLY with other fuses of the same type.
- As the mains cable of the UPS is considered a disconnecting device, the mains socket to which the UPS is connected and/or the rear of the UPS must be accessible and easy to disconnect.
- Avoid contact of the UPS unit with water or liquids in general. Do not introduce foreign bodies.
- If the unit needs to be scrapped, it must be handed over solely and exclusively to specialist disposal companies. These companies are obliged to break up and dispose of the various components in accordance with the national legal provisions in force.
- The UPS generates a leakage current of about 1.5mA. To guarantee the maximum limit leakage current of 3.5mA, make sure that the maximum leakage current of the load is 2 mA. If the load current exceeds this value, have qualified personnel connect the UPS to an industrial type, IEC 309 compliant power supply mains, with a current of correct dimensions for the UPS power rating.
- NeTYS UPS is intended for commercial and industrial use; it is not recommended for use in medical applications that are essential to the survival of the patient.
- Use the UPS in accordance with the technical specifications given in the User Manual.

## 2. GENERAL DESCRIPTION

### NeTYS: sure power supply for PC, servers, graphics stations and network devices.

The main purpose of the UPS is to protect sensitive and critical equipment from electrical disturbances that can compromise operation. Black-outs, brown-outs, variations in voltage and frequency, lightning, electrostatic discharges and rapid over voltages are phenomena found in all office and industrial environments and which cause damage to the hardware and loss of data.

NeTYS is an Uninterruptible Power Supply designed to power computers and connected peripherals, with the exception of any other electrical device (such as household appliances, television sets, stereo systems and video recorders) that may be connected only to the filtered output sockets.

### INTRODUCTION

The characteristic feature of these UPS is the constant monitoring of the power supply which, duly filtered and if considered suitable, is used to supply consumers. In cases of a mains failure or if the mains is considered to be outside limits accepted by the load, the inverter (the heart of the UPS) is activated immediately. Drawing on the power stored in the batteries, the inverter generates a voltage that instantly takes over from the mains without any disruption to the equipment connected.

During operation under emergency conditions, the internal batteries discharge but are recharged again automatically when mains power returns.



Being hermetically sealed, the batteries do not require maintenance of any kind at any stage of their working life.

### Block diagram

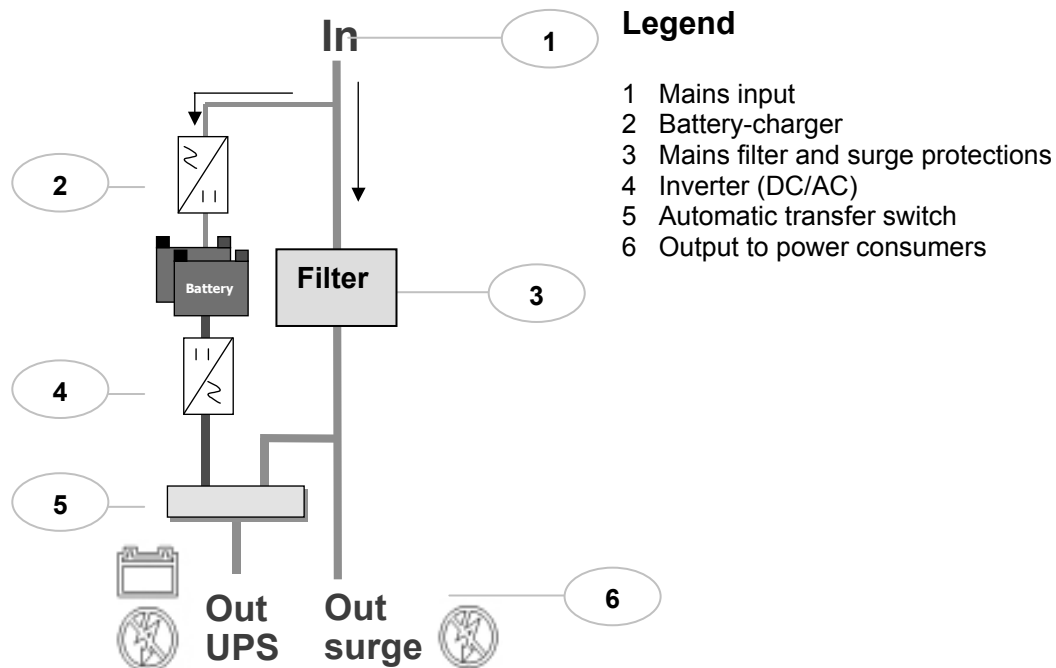
The block diagram provides a useful aid to understanding how the machine operates.



## 2.1. LED-BASED CONTROL AND DISPLAY PANEL

	<p> <b>ON/OFF switch</b> Turns the UPS ON and OFF</p> <p><b>Visual indication of operating mode</b> LED (green) lit = <b>NORMAL MODE</b> (mains OK) LED (yellow) flashing = <b>BATTERY MODE</b> (mains absent or abnormal)</p> <p> UPS failure LED (red)</p> <p><b>Acoustic alarm ((o))</b> Intermittent alarm every 5 seconds = BATTERY MODE Intermittent alarm every second = battery low Intermittent alarm every 0.5 second = overload Continuous alarm = UPS failure</p>
---	---

## 3. UNPACKING AND INSTALLATION

---

### 3.1. UNPACKING

Remove the UPS and all the accessories that come with it (cables, product manual, etc) from its packing case.

It is always advisable to keep the original packaging that has been specially designed for safe transport, in case the unit has to be moved again.

### 3.2. ENVIRONMENTAL REQUIREMENTS FOR INSTALLATION

*Install the UPS after first checking the following:*

- NeTYS has been designed for use in closed environments.
- Place the UPS on a flat and stable surface, in a ventilated environment away from heat sources and exposure to direct sunlight.
- Keep ambient temperature between 0°C and 40°C and humidity less than 90% (non-condensing); the best temperature to guarantee longest possible battery life is 15-20°C.
- Ensure that the environment where the UPS will be installed is not dusty, and leave a space of at least 20 cm around it to allow for adequate ventilation and access to the rear panel.
- Make sure not to place the UPS or any other heavy object on the cables.
- Check that the voltage and frequency preset for operation is right for your electrical power supply looking the data can be found on the data plate.
- Use only the manufacturer-supplied or recommended cables and accessories for connections to the RS232/USB serial interface

It is recommended that the batteries be left to charge for 8 hours the first time the unit is used.

### 3.3. CONNECTION TO THE MAINS POWER SUPPLY AND CONNECTING THE LOAD

Cables with the appropriate cross-section and conforming to the safety standards in force should be used for connection to the mains and connection of the loads.

**Connect the UPS power cord to the mains power supply**

**Connect the loads to the outlet sockets on the rear of the UPS.**

#### SWITCHING THE UPS ON

Switch the UPS on by pressing the ON button on the front panel. The “Normal mode” LED will light up: allow ten seconds for the self-teach procedures to run.

When you are sure that the UPS is functioning properly, the various loads may be switched on and work may commence in protected mode.

#### SWITCHING THE UPS OFF

***Warning! This UPS has been designed to control and maintain the battery charge; therefore only in exceptional circumstances are you advised to switch it off completely***

To shutdown the UPS completely, press and hold down the OFF button. The UPS switches off all the LEDs and is then fully deactivated.

## 4. OPERATING MODES

---

### NORMAL MODE

When mains power is available and the voltage falls within the acceptable range, the **NORMAL MODE** LED on the front panel remains on permanently. In this mode, the loads are powered from the mains power supply directly and protected in cases of voltage peaks. The batteries are constantly recharged.

### BATTERY MODE

The UPS switches automatically to this operating mode when mains power fails (spikes or lengthy black-outs) or if the mains is at a value considered to be dangerous; the consumers are powered using the energy stored in the batteries converted to AC voltage through the inverter.

In this mode, a slow intermittent acoustic alarm sounds, while the **BATTERY MODE** LED on the front panel flashes.

In cases of prolonged mains failure, the UPS powers the consumers until it shuts down when the batteries are fully depleted (see the chapter on COMMUNICATION for orderly shutdown via software).

Just before shutdown when the battery charge runs out fully, low battery charge is signalled via a rapid intermittent acoustic alarm.

The UPS automatically returns to normal operating mode about two seconds after the mains power is restored. The time taken to transfer from normal to battery mode and vice-versa is imperceptible to the load.

### OVERLOAD

The UPS can power loads up to the power rating declared on the machine's data plate; once this limit is exceeded, the machine goes into overload condition.

Overloads are signalled by a rapid sounding acoustic alarm .

Warning: Significant overloads could cause permanent damage to the UPS!

Avoid connecting laser printers that generate absorption peaks liable to cause overloads on the UPS.

## 5. COMMUNICATION

---

The UPS provides excellent protection against interruptions or imperfections in the mains power supply. In these cases the computer (load) is powered by the UPS using battery power until this runs out.

Various software applications and communication options are available to optimise operation of the UPS and to correctly manage shutdown when back-up power ends. The status of the UPS can be monitored, keeping track of all the mains failures and battery discharges so as to activate an automatic and orderly procedure to close the programs and shutdown the system. When mains power returns the system will restart automatically.

All NeTYS models are equipped with RS232 and USB communication interface

### COMMUNICATION SOLUTIONS

**Uni Vision** *local management software* for local shutdown of Windows™ & Linux systems.

**Free on [http://www.socomec.fr/page\\_uk/lien\\_prod\\_ups.htm](http://www.socomec.fr/page_uk/lien_prod_ups.htm)**

### RS232/USB INTERFACE

Communication with the server can take place directly via the **RS232/USB** interface.

In addition to local or networked shutdown it is possible to perform full monitoring of the electrical parameters regarding battery status and the automatic programming of the UPS start-up and shutdown procedures.

For a complete description of the software features, refer to the **Uni Vision**.



## 6. MAINTENANCE

### 6.1. REMEDIES FOR MINOR PROBLEMS

This section examines some of most likely problems that can compromise correct operation of the UPS, attempting to solve them and identifying the possible causes and remedies.



THE UPS INTERNALLY GENERATES HAZARDOUS ELECTRICAL VOLTAGES. ALL MAINTENANCE MUST BE PERFORMED SOLELY AND EXCLUSIVELY BY AUTHORIZED PERSONNEL.

If you have difficulty in getting the UPS to work, the reason may be among those listed below. For any other problem, you are advised to get in touch with your dealer or service organisation directly. For quick and effective action, when you call it is important to give precise details of the defect, the model number and the manufacturing serial number that can be found on the conformance and inspection certificate or on the data plate on the bottom of the UPS.

PROBLEM	CAUSE	SOLUTION
The UPS works in battery mode even if mains power is available	- Poor connection to the input mains.  -The mains voltage is out of range	-Check the connection of the cable to the UPS and to the mains outlet.  -No solution because mode of operation is correct.
Back-up time shorter than expected	-Batteries not fully charged.  -Batteries not working properly.	-Leave the batteries to charge for 8 hours consecutively.  -Have the batteries replaced by authorised personnel.
The UPS stalls/goes into overload alarm	Overload on the load line.	Check that the load applied is not greater than the maximum permitted or reduce the load power requirement.

IF THE EQUIPMENT IS TO BE LEFT IDLE FOR A LONG PERIOD, WAIT FOR THE BATTERIES TO CHARGE FULLY BEFORE SWITCHING OFF. WHILE THE UPS IS LEFT IDLE, MAKE SURE THAT THE BATTERIES ARE RECHARGED FOR 24 HOURS AT LEAST ONCE EVERY 4 WEEKS.

## 7. TECHNICAL DATA

NeTYS PL	550	750
Power (UPS protection)	550 VA (330 W)	750 VA (450 W)
Power (Surge protection)	1200 VA	1200 VA
Technology	High Frequency Step Wave	

### INPUT

Voltage	170 - 260 V
Frequency	50 / 60 Hz with automatic selection
Mains connection	Cable with plug

### OUTPUT

Voltage (in Battery Mode)	230V ± 10%
Frequency	50 / 60 Hz ± 1 Hz
Wave form	Stepwave
Transfer time	2-6 milliseconds (typical)
Protection	Overload, deep discharge and short circuit
Load connection socket UPS and Surge protection	# 4 schuko type + IT / FR* (CEI 23-50)
Load connection socket Surge protection	# 2 schuko type + IT / FR* (CEI 23-50)

### BATTERY

Typical back-up time PC+15" LCD monitor	20 min.	30 min.
--	---------	---------

### COMMUNICATION

Communication interface	RS232/USB
Local communication software	UPS Management software – Windows™ & Linux (free download)
Telephone protection	Telephone line/modem/ADSL suppressors: RJ 11/45

### ENVIRONMENT

Noise level at 1 meter	< 45dBA
Temperature	0- 35°C (15- 25°C for optimum battery life)
Environment	Altitude: 2000 mt, humidity: 90% non-condensing
Reference Standards	(EN) IEC 62040-1-1 (safety), EN 50091-2/IEC 62040-2 (EMC), EN 61000-4-5/C62.41:1991 (surge); CEI 23-50; IEC 60884-1

### WEIGHT AND DIMENSIONS

Dimensions (WxDxH mm)	160 x 210 x 125	
Net weight	5,3 Kg	5,5 Kg

\* Specific model with French plug