

# DESKPOWER 2000 Series User's Manual

Fujitsu endeavours to ensure that the information in this document is correct, but accepts no liability for any error or omission in the same. Any procedures described in this document for operating Fujitsu products should be read and understood by the operator before such products are used. To ensure that Fujitsu products function without risk to safety and health, such procedures should be strictly observed by the operator. The development of Fujitsu products and services is continuous and published information may not be up to date. Any particular issue of a product may contain facilities not described herein. It is important to check the current position with Fujitsu. Specifications and statements as to performance in this document are Fujitsu estimates intended for general guidance. They may require adjustment in particular circumstances and should therefore not be taken as formal offers or commitments.

DESKPOWER is a trademark of Fujitsu Limited. The following are registered trademarks of Microsoft Corporation: MS, MS-DOS, Windows® NT, Windows® 98, Windows Millennium, Window® 2000 and Windows XP.

Intel and Pentium are registered trademarks of Intel Corporation in the U.S.

Celeron is a registered trademark of Intel Corporation in the U.S.

ATI and RADEON are registered trademarks of ATI Technologies, Inc.

Other product names are trademarks or registered trademarks of respective companies.

Other products are copyrighted by individual companies.

All other trademarks referenced are trademarks or registered trademarks of their respective owners, whose protected rights are acknowledged.

Copyright © Fujitsu Siemens Computers GmbH 2001

All rights, including rights of translation, reproduction by printing, copying or similar methods, in part or in whole, are reserved.

Offenders will be liable for damages.

All rights, including rights created by patent grant or registration of a utility model or design, are reserved.

Delivery subject to availability. Right of technical modification reserved.



## DECLARATION OF CONFORMITY according to FCC Part 15 Class B

This device complies with Part 15 Class B of the FCC Rules. Operations are subject to the following two conditions:

(1) This device may not be allowed to cause harmful interference, (2) This device must accept any interference received, including interference that may cause undesired operation.

Website: [www.fujitsu-pc-asia.com](http://www.fujitsu-pc-asia.com)

# IMPORTANT SAFETY INSTRUCTIONS

1. Read these instructions carefully. Save these instructions for future reference.
2. Follow all warnings and instructions marked on the product.
3. Unplug this product from the wall outlet before cleaning. Do not use liquid cleaners or aerosol cleaners. Use a damp cloth for cleaning.
4. Do not use this product near water.
5. Do not place this product on an unstable cart, stand, or table. The product may fall, causing serious damage to the product.
6. Slots and openings in the cabinet and the back or bottom are provided for ventilation; to ensure reliable operation of the product and to protect it from overheating, these openings must not be blocked or covered. The openings should never be blocked by placing the product on a bed, sofa, rug, or other similar surface. This product should never be placed near or over a radiator or heat register, or in a built-in installation unless proper ventilation is provided.
7. This product should be operated from the type of power indicated on the marking label. If you are not sure of the type of power available, consult your dealer or local power company.
8. This product is equipped with a 3-wire grounding-type plug, a plug having a third (grounding) pin. This will only plug into a grounding-type power outlet. This is a safety feature. If you are unable to insert the plug into the outlet, contact your electrician to replace your obsolete outlet. Do not defeat the purpose of the grounding-type plug.
9. Do not allow anything to rest on the power cord. Do not locate this product where persons will walk on the cord.
10. If an extension cord is used with this product, make sure that the total ampere rating of the equipment plugged into the extension cord does not exceed the extension cord ampere rating. Also, make sure that the total rating of all products plugged into the wall outlet does not exceed 15 amperes.
11. Never push objects of any kind into this product through cabinet slots as they may touch dangerous voltage points that could result in a fire or electric shock. Never spill liquid of any kind on the product.
12. Do not attempt to service this product yourself, as opening or removing covers may expose you to dangerous voltage points or other risks. Refer all servicing to qualified service personnel.

13. Unplug this product from the wall outlet and refer servicing to qualified service personnel under the following conditions:
  - a. When the power cord or plug is damaged or frayed.
  - b. If liquid has been spilled into the product.
  - c. If the product has been exposed to rain or water.
  - d. If the product does not operate normally when the operating instructions are followed. Adjust only those controls that are covered by the operating instructions since improper adjustment of other controls may result in damage and will often require extensive work by a qualified technician to restore the product to normal condition.
  - e. If the product has been dropped or the cabinet has been damaged.
  - f. If the product exhibits a distinct change in performance, indicating a need for service.
  
14. **CAUTION. When replacing the battery, be sure to install it with the polarities in the correct position. There is a danger of explosion if the battery is replaced with an incorrect type or is mistreated. Do not recharge, disassemble or dispose of in fire. Replace only with the same or equivalent type recommended by the manufacturer. Dispose of the used battery according to the manufacturer's instructions.**
  
15. Use only the proper type of power supply cord set (provided in your accessories box) for this unit. It should be a detachable type: UL listed/CSA certified, BS1363,ASTA,SS145 certified, rated 10A 250V minimum, VDE approved or its equivalent. Maximum length is 15 feet (4.6 meters).
  
16. **NOTE:**  
**Please take extra precaution when connecting the LAN cable; do not connect the LAN cable to the peripheral device's connector, that might have excessive voltage.**

# Before reading this manual

This section describes safety precautions and convention used in this manual. Be sure to read this.

## For Safe Operation

This manual contains important information for using the DESKPOWER personal computer. Read this manual thoroughly before using your PC. In particular, "Safety Precautions" in this manual must be read and understood. This manual including "Safety Precautions" must be readily available at all times.

This equipment is compliant with the PC industry standard (PC-11-1988) of the Japan Electronics and Information Technology Industries Association.

## Note

This product is a Class B Information Technology Equipment and conforms to the standard set by the Voluntary Control Council for Interference by Technology Equipment (VCCI). This product is designed to be used in a domestic environment, however, it may cause radio interference when used in the vicinity of a radio or television receiver. Make sure that you read the manual when using this product.

Fujitsu, as a member of the International Energy Star Program, recognizes that this equipment is compliant with the standard of the International Energy Star Program.



The International Energy Star Program is a worldwide program for promoting energy saving for computers and other office equipment. The program aims at promoting the development and use of products equipped with the functions that can effectively reduce energy consumption and uses a voluntary system that allows enterprises to join at their own discretion. The target products are office equipment including computers, displays, printers, facsimiles, and copying machines. The standards for individual types of equipment and the mark (  ) prepared by the Program are used commonly among member countries.

## Caution

This equipment is class B information technology equipment based on the standard of the Voluntary Control Council for Interference by Information Technology Equipment (VCCI). Although the equipment is intended for use in residential environments, it may create interference if placed near radio or television. Handle the equipment in accordance with the manual.

### **Using this Product for High-Safety Applications**

This product is for office, personal, home, ordinary industry and other general use. It is not designed and manufactured for use in high-safety applications.

Do not use this product for such applications without taking measures to satisfy the high-safety requirements.

High-safety applications require extremely high level of safety, and involve serious hazards to life and health if the required safety is not assured. High-safety applications include the following.

- Nuclear reaction control in nuclear facilities, automatic aviation control, air traffic control, mass-transportation control, life-supporting medical equipment, and missile launch control.

Some parts (including the CRT display, LCD, or hard disk drive) used on this product have a limited life. When used continuously for a prolonged period, these parts will need earlier replacement.

### **Backing Up the Data**

The customer is responsible for maintaining the integrity of data (including the basic and application software) stored or installed on the product. We do not warrant the integrity of data stored or installed on the personal computer the customer sent for repair. Take appropriate measures such as making a backup.

We assume no responsibility for loss of data and any direct or incidental damage due to any cause other than those specified in the warranty.

This computer is designed for use within the country. If you are using it abroad, please do so on your own responsibility.

This equipment may be adversely affected by the momentary drop of the supplied voltage due to lightning. Use of an AC uninterruptible power supply is recommended for measures against the momentary drop of the supplied voltage.

(This message is based on the Japan Electronics and Information Technology Industries Association's guidelines for measures against momentary voltage drop in PCs.)

Since this equipment contains special materials controlled by the Foreign Exchange and Foreign Trade Control Law. Authorization under the law may be required to export this equipment.

**Microsoft Service Pack**

Microsoft Corp. offers Service Pack to provide the users of Microsoft® Windows® with more stable system operation (<http://www.microsoft.com/>).

The latest version of the Service Pack helps you configure the most stable system using Microsoft® Windows® provided at that time by Microsoft Corp.

We recommend you to use the latest version.

In some environments, however, the Service Pack may cause unexpected failure. Read Readme.txt for the Service Pack before use.

Again, we recommend you to make a system backup in case of failed installation.

Components of this product (motherboard, CD-ROM, hard disk, and floppy disk drive) contain traces of heavy metals (lead and chrome) and chemical (antimony).

# Conventions Used in This Manual

## Introduction

This operating manual tells you how to put your PC into operation and how to operate it in daily use. The Operating Manual applies for all configuration levels. Depending on the configuration level chosen some of the hardware components described may not be available on your PC. Please observe the notes on your operating system.



You can incorporate operable drives (for example DAT drive) as well as other boards.

Depending on the configuration selected, the operating system is preinstalled on your hard disk (e.g. Windows 2000).

Your PC has a number of security features to ensure that no unauthorised persons can access your data, for example, you can activate a screen saver with password protection. For example, you can activate a screen saver with password protection. The security functions in the BIOS Setup also allow you to protect your data by means of passwords. Systems with a SmartCard reader offer additional protection.

## Notational conventions

The meanings of the symbols and fonts used in this manual are as follows:

 <b>CAUTION</b>	Indicates information which is important for your health or for preventing physical damage.
	Indicates important information which is required to use the system properly.

- Text which follows this symbol describes activities that must be performed in the order shown.

Text in this typeface indicates screen outputs.

"Quotation marks" indicate names of chapters or terms.

## Important Notes

In this chapter you will find information regarding safety which is essential to take note of when working with your PC. The manufacturer's notes contain helpful information on your PC.

### Safety

#### CAUTION

---

During installation and before operating the device, please observe the instructions on environmental conditions in the chapter entitled "Technical data" as well as the instructions in the chapter "Preparing for Use".

Please check whether the device is correctly set for the local power supply (see "Preparing for Use" chapter).

The main switch and the ON/OFF switch do not disconnect the system unit from the mains voltage. To completely disconnect the mains voltage, remove the power plug from the grounded mains outlet.

Replace the lithium battery on the system board in accordance with the instructions in the "System expansions - Replacing lithium battery" chapter.

Caution: components in the system can get very hot.

### Manufacturer's notes

Keep this operating manual together with your device. If you pass on the device to third parties, you should include this manual.

### Energy saving

When the PC is delivered, some energy-saving functions are already set (see the technical manual for the system board or the "BIOS Setup" manual).

- If you are not using your PC, switch it off.
- In the BIOS Setup you may set further energy-saving functions for the PC.
- Depending on the operating system, you can set additional power-management features.

#### **Energy saving under Windows 2000**

The Screen Saver tab allows you to set energy-saving functions for your screen. Select the following item in the menu: Start → Settings → Control Panel → Display → Display Properties → Screen Saver → Energy saving features of monitor.

With the default setting Control Panel → Power Options → Advanced additional power management features of Windows 2000/XP are available.



## □ **FCC Class B Compliance Statement**

The following statement applies to the products covered in this manual, unless otherwise specified herein. The statement for other products will appear in the accompanying documentation.

### **NOTE:**

This equipment has been tested and found to comply with the limits for a "Class B" digital device, pursuant to Part 15 of the FCC rules and meets all requirements of the Canadian Interference-Causing Equipment Regulations. These limits are designed to provide reasonable protection against harmful interference in a residential installation. This equipment generates, uses and can radiate radio frequency energy and, if not installed and used in strict accordance with the instructions, may cause harmful interference to radio communications. However, there is no guarantee that interference will not occur in a particular installation. If this equipment does cause harmful interference to radio or television reception, which can be determined by turning the equipment off and on, the user is encouraged to try to correct the interference by one or more of the following measures:

- Reorient or relocate the receiving antenna.
- Increase the separation between equipment and the receiver.
- Connect the equipment into an outlet on a circuit different from that to which the receiver is connected.
- Consult the dealer or an experienced radio/TV technician for help.

Fujitsu is not responsible for any radio or television interference caused by unauthorised modifications of this equipment or the substitution or attachment of connecting cables and equipment other than those specified by Fujitsu. The correction of interference caused by such unauthorised modification, substitution or attachment will be the responsibility of the user.

The use of shielded I/O cables is required when connecting this equipment to any and all optional peripheral or host devices. Failure to do so may violate FCC rules.

## ❑ Transporting the PC

### CAUTION

---

Transport all parts separately in their original packaging or in a packaging which protects them from knocks and jolts, to the new site. Do not unpack them until all transportation manoeuvres are completed.

Never drop the monitor!

## ❑ Cleaning the PC

### CAUTION

---

Turn off all power and equipment switches and remove the power plug from the mains supply.

Do not clean any interior parts yourself, leave this job to a service technician.

Do not use any cleaning agents that contain abrasives or may corrode plastic.

Ensure that no liquid enters the system.

Ensure that the ventilation areas of the system unit and the monitor are free.

#### **Cleaning the system unit and the monitor**

Wipe the system unit and monitor casing with a dry cloth. If particularly dirty, use a cloth that has been moistened in mild domestic detergent and then carefully wrung out.

#### **Cleaning the keyboard and the mouse**

Use disinfectant wipes to clean the keyboard and the mouse.

The mouse mechanism and the mouse ball can be cleaned by removing the retaining ring on the underside of the mouse.



Additional information can be found in the documentation for your keyboard and mouse.

## □ **Disposal and recycling**

This device has been manufactured to the highest possible degree from materials which can be recycled or disposed of in a manner that is not environmentally damaging. The device may be taken back after use to be recycled, provided that it is returned in a condition that is the result of normal use. Any components not reclaimed will be disposed of in an environmentally acceptable manner.

Do not throw lithium batteries into the household waste. They must be disposed of in accordance with local regulations concerning special waste.

## Reference to products

In this manual, the product names are referred to as follows:

This manual includes information on other operating systems.

Product name	Description used in the manual		
Microsoft® Windows® XP Professional	Windows XP Professional	Windows XP	Windows*
Microsoft® Windows® XP Home Edition	Windows XP Home Edition		
Microsoft® Windows® 2000 Professional	Windows 2000		
Microsoft® Windows NT® Workstation Operating System Version 4.0	Windows NT		
Microsoft® Windows® Millennium Edition	Windows Me		
Microsoft® Windows® 98 operating system SECOND EDITION	Windows 98		
Microsoft® MS-DOS® operating system	MS-DOS		

Note: Descriptions such as Windows XP/2000/NT/Me/98 are used.

# Warning and caution labels

Your PC bears the warning and caution labels as shown below.  
The warning and caution labels must not be removed or damaged.

## Rear of the PC main unit

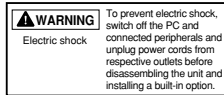
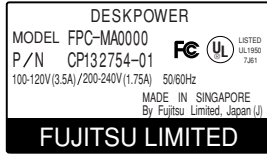
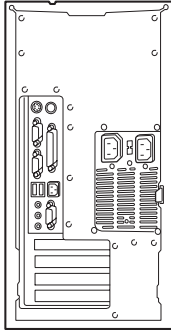

## Inside the PC main unit

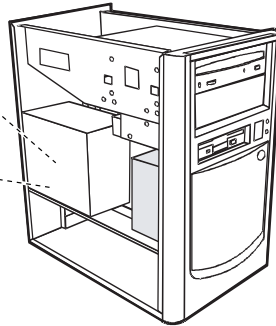
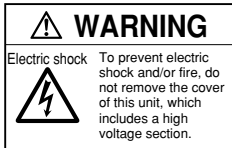

### ATTENTION

115V of voltage switch in the power supply corresponds to 100-120V  
230V of voltage switch in the power supply corresponds to 200-240V

### WARNING

Electric shock



- Before mounting or dismounting an optional unit in/from your PC, switch off the PC and all connected units and unplug all power cords from respective outlets to prevent electric shock.

# Organization of This Manual

## **Before Reading This Manual**

This section contains cautions for safe operation, representations and symbols used in this manual. Be sure to read this first!

## **Chapter 1 Preparing for Use**

This chapter provides the names and functions of individual parts.

## **Chapter 2 Operation**

This section describes the location of installation and installation of the computer.

## **Chapter 3 Troubleshooting and Tips**

This chapter provides the basic information on the PC and operation.

## **Chapter 4 System Expansion**

This chapter provides basic information on how to handle the peripherals installed (or can be installed) on the PC.

## **Chapter 5 Technical Data**

This chapter describes the specifications of this PC.

# Contents

## CHAPTER 1 Preparing for Use

<b>1 Preparing for Use</b> .....	<b>2</b>
Unpacking and Checking the Delivery .....	2
Steps for Initial Setup .....	2
Setting Up the PC .....	3
Connect the Monitor, Mouse and Keyboard .....	3
Connecting the PC to the Mains Voltage .....	5
Initial Switch-on: Software will be Installed .....	6
Connecting External Devices .....	8

## CHAPTER 2 Operation

<b>1 Operation</b> .....	<b>12</b>
Switching On the PC .....	12
Switching Off the PC .....	13
Indicators on the system unit .....	14
<b>2 Keyboard</b> .....	<b>15</b>
<b>3 Floppy Disks</b> .....	<b>17</b>
Working with Floppy Disks .....	17
Settings in BIOS Setup .....	18
Property and Data Protection .....	18
Access Protection Under Windows .....	18
BIOS Setup Security Functions .....	19

## CHAPTER 3 Troubleshooting and Tips

<b>1 Troubleshooting and Tips</b> .....	<b>22</b>
Installing New Software .....	22
Power-on Indicator Remains Unlit After You Have Switched on Your Device .	22
No Mouse Pointer Displayed on the Screen .....	24
The Floppy Disk Cannot be Read or Written .....	24
Time and/or Date is Not Correct .....	25
Tips .....	25

**CHAPTER 4      System Expansion**

**1 System Expansions ..... 28**  
Information about boards ..... 28  
Opening the System Unit ..... 29  
Assembling the System Unit ..... 30  
Installing and Removing a Board ..... 30  
Installing and Removing Drives ..... 33

**CHAPTER 5      Technical Data**

**1 Technical Data ..... 44**  
Electrical Data ..... 44  
List of Specifications ..... 45  
Index ..... 46



# **CHAPTER 1**

---

---

## **Preparing for Use**

---

---

# 1 Preparing for Use

## CAUTION

---

Please take note of the safety information in the "Important notes" chapter.

## ■ Unpacking and Checking the Delivery

It is recommended not to throw away the original packaging material! It may be required for reshipment at some later date.

- Unpack all the individual parts.
- Check the delivery for damage incurred during transportation.
- Check whether the delivery agrees with the details in the delivery note.

Should you discover that the delivery does not correspond to the delivery note, notify your local sales outlet immediately.

## ■ Steps for Initial Setup

First-time setup includes the connection of the monitor, mouse and keyboard to the system unit and the setup of the supplied software.



### ● External devices

If you have received other devices in addition to your PC (e.g. a printer or a modem), do not connect these until after the initial installation. The following sections contain a description of how to connect these external devices: "Connecting external devices to the serial port" and "Connecting external devices to the parallel port".

### ● Drives and boards

If you have received drives or boards with your PC, please do not install them until after first-time setup. How to install drives and boards is described in the chapter "System expansions".

Perform the following steps in the prescribed order:

1. Decide where you are going to use the PC, and then set it up.
2. Connect the monitor, mouse and keyboard to the PC.
3. Check the rated voltage of the PC and connect it to the mains voltage.
4. Switch the PC on and follow the instructions on the screen.

## ■ Setting Up the PC

### CAUTION

---

When installing your PC, give consideration to the recommendations and safety notes.

Set up the PC only in its correct orientation. The points to observe are illustrated on the following pages.

We recommend that you place your equipment on a surface with good anti-slip qualities. In view of the multitude of different finishes and varnishes used on furniture, it is possible that the rubber feet of the devices will mark the surface they stand on.

Do not expose the PC to extreme environmental conditions (see chapter "Technical data") and protect it from dust, humidity and heat.

Provide at least 200 mm of clearance on the left, in front of and behind the ventilator area of the system unit to ensure adequate ventilation. Do not cover the ventilation areas of the monitor and the system unit.

Do not place several system units one above the other.

## ■ Connect the Monitor, Mouse and Keyboard

The ports for monitor, mouse and keyboard are on the rear and on the front of the system unit.



PS/2 keyboard port / purple



PS/2 mouse port / green



Monitor port / blue



USB port / black

### Connecting the keyboard

#### Connecting standard keyboard

Use the supplied keyboard cable only.

- Plug the other end of the keyboard cable (square plug) into the socket on the underside of the keyboard.
- Plug the round keyboard cable connector into the port marked with this symbol on the  system unit.

## ❑ Connecting the mouse

### Connecting a PS/2 mouse

- Connect the PS/2 mouse to the PS/2 mouse port  on the system unit.

### Connecting USB mouse

- Connect the USB mouse to the USB port  on the system unit.



---

If you do not attach a mouse at the PS/2 mouse port , you can disable the mouse controller in the BIOS Setup in order to free the IRQ12 for a different application.

## ■ Connecting the PC to the Mains Voltage

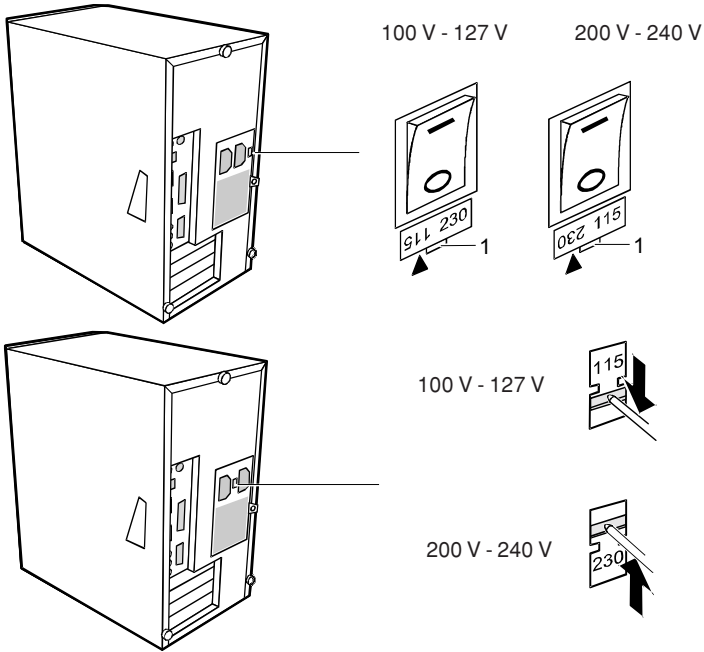

### 1 Notch for inserting the screwdriver

If the power supply of your PC does not have a slide-in or plug-in element for setting the rated voltage, then your system automatically sets itself to the local rated voltage. If you have a PC with a slide-in or plug-in element, then you must match the set rated voltage to the local rated voltage.

- Check the voltage setting.

## CAUTION

### ● Devices with main power switch:

The value indicated with an arrow must be compatible with the local rated voltage:

- 115 = 100 V to 127 V
- 230 = 200 V to 240 V

If the voltage setting is incorrect, then lift out the manual voltage adjuster with a screwdriver (1), turn it to the required setting and reinsert it.

### ● Devices without main power switch:

The visible value must agree with the local mains voltage:

- 115 = 100 V to 127 V
- 230 = 200 V to 240 V

If an incorrect mains voltage is set, push the slide switch all the way into the other possible position with a pointed object.

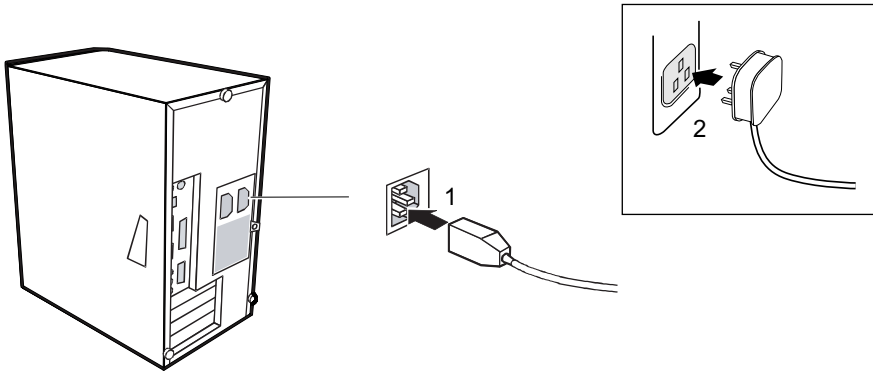

- Plug the system unit's power cable into the system unit (1) and then into the grounded mains outlet (2).

## ■ Initial Switch-on: Software will be Installed

If the PC is connected to a network, the network protocol is required as well as the user and server details. Contact your network administrator if you have any questions about these settings.

When you switch on your PC for the first time, the supplied software is installed and configured. You should plan some time for this, as this process must not be interrupted.

### CAUTION

---

Once the installation has been started the PC must not be switched off!

During installation the PC may only be rebooted when you are requested to do so!

Otherwise the installation will be not be performed correctly. If a fault occurs during the installation, the contents of the hard disk must be completely restored.

You may need the licence number for Windows during the installation. This number is located on a sticker on your PC.

#### Switching on monitor and PC

- Switch the monitor on (see the operating manual for the monitor).
- Switch the PC on. To do this, follow the instructions below.

## Switching on PC with devices with main power switch

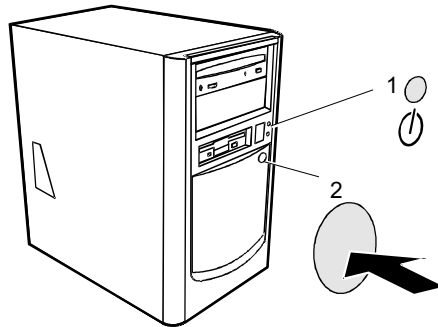

### 1 Power button

### 2 Power-on indicator

- If the power-on indicator lights orange or flashes green/orange, press the power button on the front of the casing.

The power-on indicator lights green and the PC is started.

### Installing the software

- During installation, follow the instructions on screen.

Consult the operating system manual if there is anything unclear about the requested input data.

## ■ Connecting External Devices



### CAUTION

---

Do not connect or disconnect cables during a thunderstorm.

Always take hold of the actual plug. Never unplug a cable by pulling the cable itself.

Connect and disconnect the cables in the order described below.

With the exception of USB devices, always remove all power plugs before connecting external devices!

Read the documentation on the external device before connecting it.

#### Connecting cables

- Turn off all power and equipment switches.
- Pull all power plugs out of grounded mains outlets.
- Connect all cables at the system unit and peripherals. You must observe the information provided in the chapter "Important notes".
- Plug all data communication cables into the utility sockets.
- Plug all power cables into the grounded mains outlets.

#### Disconnecting cables

- Turn off all power and equipment switches.
- Pull all power plugs out of grounded mains outlets.
- Unplug all data communication cables from the utility sockets.
- Disconnect all cables from the system unit and peripherals.



---

USB devices are hot-pluggable. This allows cables from USB devices to be connected and disconnected with the system switched on.

Additional information can be found in the documentation for the USB devices.



## □ Connections on the system unit

The ports for external devices are on the rear and on the front of the system unit. The ports available on your PC depend on the configuration level you have selected. The standard ports are marked with the symbols shown below (or similar). Exact details of the position of the ports are supplied in the technical manuals for the boards.



Keyboard port / purple



PS/2 mouse port / green



Serial interface 1 / turquoise



Serial interface 2 / turquoise



Monitor port / blue



Parallel interface / Printer / burgundy



Headphones port / orange



Microphone jack (mono) / pink



Audio output (Line out) / lime green



Audio input (Line in) / light blue



Game port / gold SCSI connection



USB - Universal Serial Bus / black

LAN



LAN connector



Some of the devices that you connect require special drivers (see the operating system and device documentation).

## ❑ Connecting external devices to the serial port

External devices can be connected to the serial port (e.g. a modem).

- Connect the data cable to the external device.
- Connect the data cable to the serial port .

For an exact description of how to connect external devices to the serial port, please refer to the device documentation.



### ● Settings of the serial port

If you need to change the settings of the serial port (e.g. address, interrupt), you can do so in the BIOS Setup.

### ● Device drivers

The devices connected to the serial port require drivers. Your operating system already includes many drivers. Nevertheless, if the driver you need is not on the hard disk, please install it from the data carrier supplied with the device or with the application programme.

## ❑ Connecting external devices to the parallel port

External devices can be connected to the parallel port (e.g. a printer).

- Connect the data cable to the external device.
- Connect the data cable to the parallel port .

For an exact description of how to connect external devices to the parallel port, please see the device documentation.



### ● Settings of the parallel port

If you need to change the settings of the parallel port (e.g. address, interrupt), you can do so in the BIOS Setup.

### ● Device drivers

The devices connected to the parallel port require drivers. Your operating system already includes many drivers. Nevertheless, if the driver you need is not on the hard disk, please install it from the data carrier supplied with the device or with the application programme.

# **CHAPTER 2**

---

## **Operation**

---

# 1 Operation

## ■ Switching On the PC

- Switch the monitor on (see the operating manual for the monitor).

### On devices with main power switch

- Switch the PC on with the main power switch on the back panel.
- If the power-on indicator lights orange or flashes green/orange, press the power button on the front of the casing.

The power-on indicator lights green and the PC is started.



---

If you have assigned the system password, you must enter this when requested to do so in order to start the operating system.

### On devices without main power switch

- If the power-on indicator lights orange or flashes green/orange, press the power button on the front of the casing.

The power-on indicator lights green and the PC is started.



---

If you have assigned the system password, you must enter this when requested to do so in order to start the operating system.

## ■ Switching Off the PC

### On devices with main power switch

- Shut down the operating system properly. For Windows: select Shut Down from the Start menu.
- If the operating system does not automatically switch off the PC, switch the PC to ready to operate by pressing the power button or turn it off by pressing the main power switch when requested to do so.

If the PC is ready-to-operate, the power-on indicator is illuminated orange. The PC uses minimal energy.

When the PC is switched off with the main power switch, the power-on indicator goes off after approx. 15 seconds. The PC no longer uses any power.

### CAUTION

---

The main power switch and the power button do not disconnect the PC from the mains voltage. To completely disconnect the mains voltage, remove the power plug from the socket.

- Switch the monitor off.

### On devices without main power switch

- Shut down the operating system properly. For Windows: select Shut Down from the Start menu.
- If the operating system does not automatically switch the PC off, turn the PC to ready-to-operate when requested to do so by pressing the power button.

If the PC is ready-to-operate, the power-on indicator is illuminated orange. The PC uses minimal energy.

### CAUTION

---

The power button does not disconnect the PC from the mains voltage. To completely disconnect the mains voltage, remove the power plug from the socket.

- Switch the monitor off.

## ■ Indicators on the system unit

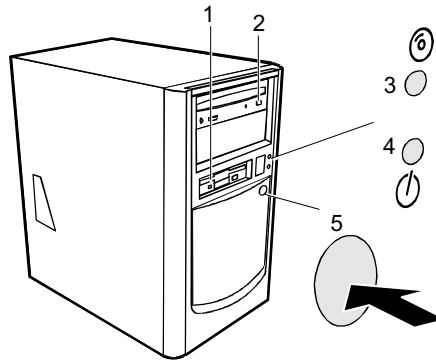

### 1 Floppy disk indicator

The indicator lights up when the floppy disk drive of the system unit is accessed. You may only remove the floppy disk when the indicator is unlit.

### 2 CD-ROM indicator

The indicator lights up when the CD-ROM drive of the system unit is accessed. You may only remove the CD when the indicator is dark.

### 3 Hard disk indicator

The indicator lights up when the hard disk drive of the system unit is accessed.

### 4 Power-on indicator

- green:  
The system unit is on.
- orange:  
The system unit is ready-to-operate.  
In this mode the PC consumes very little power and can be switched on with the power button.
- flashing green/orange:  
The indicator only flashes on systems which support the ACPI function (Advanced Configuration and Power Management Interface).  
The system unit is in the energy-saving mode (standby). After being switched on with the power button, the PC returns to the state it was in before the energy-saving mode.

## CAUTION

In an energy-saving mode the PC must not be switched off with the main power switch (if present) or disconnected from the mains, as this may result in data loss.

### 5 ON/OFF switch

Switches the PC on or off. With Windows 98 with ACPI or with Windows 2000 you can set additional functions of the ON/OFF switch in the Control Panel (Power management).

## 2 Keyboard

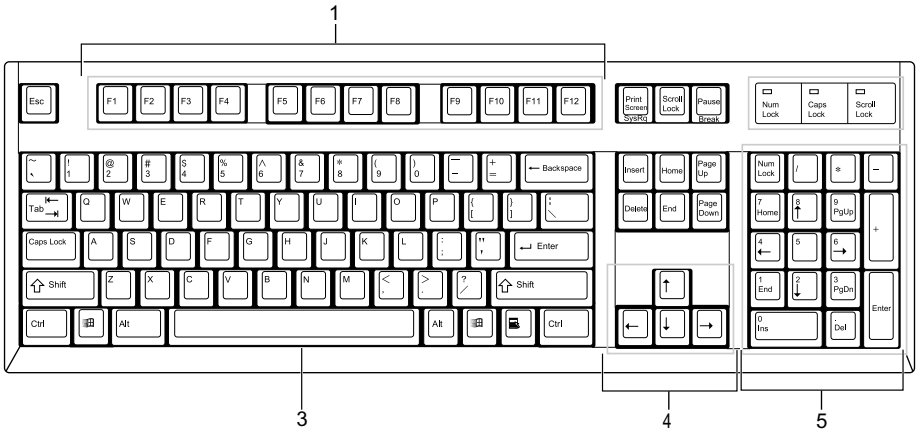

### 1 Esc key

Pressing this key cancels the operation the application program is executing.

### 2 F keys

These F keys are assigned specific functions for each application.

### 3 Back space key

Press the Back Space key to move the cursor to the left while deleting characters.

### 4 Insert key

Press the Insert key to switch between character insert mode and overwrite mode.

### 5 Print Screen key

Pressing this button copies the screenshot to the clipboard.

### 6 Home key

Press the Home key to move the cursor all at once to the beginning of the current line or text.

### 7 Indicators

The indicator lights when you press [Num Lock], [Shift] + [Caps Lock], or [Scroll Lock], indicating that it is enabled. When the key is pressed again, the indicator turns off and the key function is disabled.

### 8 Caps Lock key

Use the Caps Lock key to type alphabetical characters.

Press [Shift] + [Caps Lock] to switch between uppercase and lowercase.

## 9 Ctrl key

Use the Ctrl key in combination with another key. Its function varies with each application.

## 10 Windows key

Press the Windows key to display the Start menu.

## 11 Alt key

Use the Ctrl key in combination with another key. Its function varies with each application.

## 12 Application key

This key has the same function as clicking the right mouse button.

Press this key to display the shortcut menu of the selected item.

## 13 Enter key

The Enter key is also referred to as the Return key.

Press this key to perform line feed or execute a command.

## 14 Delete key

Press the Delete key to delete a character. Press this key together with [Ctrl] and [Alt] to reset the computer.

## 15 End key

Press the End key to move the cursor all at once to the end of the current line or text.

## 16 Cursor keys

Press each of these keys to move the cursor in the desired direction.

## 17 Page Down key

Scrolls down the on-screen page when pressed.

## 18 Page Up key

Scrolls up the on-screen page when pressed.

## 19 Numeric keypad

Enables you to enter numerals when the [Num Lock] indicator is on.

The function described in the lower part of the numeric key is enabled when the [Num Lock] indicator is off.

## 20 Num Lock key

Press the Num Lock key to change the Ten-key pad functions.

## ◎ Point

---

To tilt the keyboard, pull up the tilt foot on the both sides of the underside of the keyboard.

---

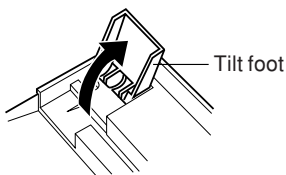



# 3 Floppy Disks

## ■ Working with Floppy Disks



Follow the instructions supplied by the vendor of the floppy disks.

Never clean the floppy disk drives with cleaning disks. Any attempt would destroy the read/write head in the disk drive within 20 seconds.

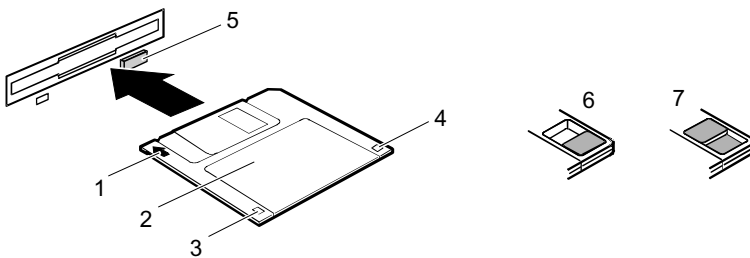

**1 Insertion direction**

**2 Label area**

**3 Write protection switch for a 720 KB or a 1.44 MB floppy disk**

**4 Identification of a 1.44 MB floppy disk or write protect switch on a 120 MB floppy disk**

**5 Eject button for inserted floppy disks**

**6 Disk is write-protected**

**7 Disk is not write-protected**

- To insert a floppy disk, push it into the drive in the insertion direction until it engages. The label should be facing upward.

- To remove the floppy disk, press the eject button (5).

The write-protect switch enables you to protect the data on the floppy disk from inadvertent overwriting or deletion.

- To protect the data on the floppy disk from being overwritten, push the write-protect switch to position (6). The hole is now visible.

- To remove write protection, push the switch to position (7). The hole is now covered.

## ■ Settings in BIOS Setup

The BIOS Setup menu allows you to set your hardware configuration and system functions. When the PC is delivered, the default entries are valid. You may customise these settings to your requirements in the BIOS Setup.

## ■ Property and Data Protection

Software functions and mechanical locking offer a broad range of functions for protecting your PC and your personal data from unauthorised access. You can also combine these functions.

### □ Anti-theft protection

There are two ways to protect your PC from theft:

- with a chain and the eyelet (1)
- with the Kensington Lock device (2) and with a Kensington MicroSaver

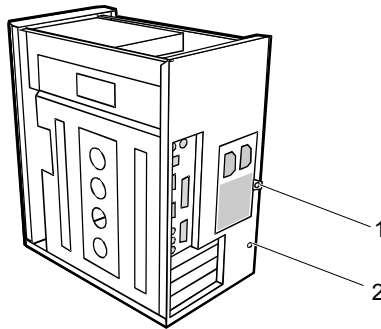

**Kensington Lock**

## ■ Access Protection Under Windows

Under MS-Windows you can activate a screen saver and protect it with a password. Only those users who know the password can deactivate the screen saver and access any open files. Detailed information on screen savers is provided by the associated help function.

## ■ BIOS Setup Security Functions

The Security menu in BIOS Setup offers you various options for protecting your personal data against unauthorised access, e.g.:

- Preventing unauthorised BIOS Setup entry
- Preventing unauthorised system access
- Preventing unauthorised access to the settings of boards with their own BIOS
- Preventing system booting from the diskette drive
- Activating virus warnings
- Preventing unauthorised writing of diskettes
- Protecting BIOS from being overwritten

You can also combine these functions.

# **CHAPTER 3**

---

## **Troubleshooting and Tips**

---

# 1 Troubleshooting and Tips



## CAUTION

---

Take careful note of the safety warnings and in the “Preparing for Use” chapter, when you connect or disconnect cables.

If a fault occurs, try to correct it as described:

- in this chapter
- in the documentation of the connected devices
- in the help systems of the software used.

If you fail to correct the problem, proceed as follows:

- Switch the PC off.
- Make a note of the steps and the circumstances that led to the fault.
- Make a note of any error messages displayed.
- Note the ID number of your device.
- Contact your sales outlet or our customer service centre.

## ■ Installing New Software

When installing programmes or drivers, important files may be overwritten and modified. To be able to access the original data in the event of any problems following installation, you should backup your hard disk prior to installation.

## ■ Power-on Indicator Remains Unlit After You Have Switched on Your Device

This may be due to the following:

### **The mains voltage supply is faulty**

- Check that the power cable is plugged properly into the system unit and grounded mains outlet.
- Switch the PC on at the power switch.

### **Internal power supply overloaded**

- Disconnect the power cable of the system unit from the grounded mains outlet.
- Wait for a moment.
- Plug the power cable into the grounded mains outlet again.
- Switch the PC on at the power switch.

## ❑ **The screen stays blank**

If your screen remains blank this may be due to the following:

### **Monitor is switched off**

- Switch your monitor on.

### **Power saving has been activated (screen is blank)**

- Press any key on the keyboard.

or

- Deactivate the screen saver. Enter the appropriate password.

### **Brightness control is set too dark**

- Adjust the brightness control. For detailed information, please refer to the operating manual supplied with your monitor.

### **Power cable not connected**

- Switch off the monitor and the PC.
- Check that the power cable of the monitor is properly connected to the monitor and, depending on the connector, to the system unit or to the grounded mains outlet.
- Check that the power cable of the PC is plugged properly into the system unit and grounded mains outlet.
- Switch on the monitor and the system unit.

### **Monitor cable not connected**

- Switch off the monitor and the system unit.
- Check that the monitor cable is properly connected to the system unit and monitor.
- Switch on the monitor and the system unit.

### **Wrong monitor has been set under Windows 2000**

- Restart the PC.
- If the message Starting Windows appears, press function key [F8].

The Windows 2000 Advanced Options Menu appears.

- Select Safe Mode or Safe Mode with Network.
- Set the correct values for the attached monitor as described in the operating manual of the monitor by selecting Start → Settings → Control Panel → Display → Settings.

### **The wrong RAM modules have been inserted**

See the technical manual for the system board for information on which memory modules can be used.

## **■ No Mouse Pointer Displayed on the Screen**

- Shut down the operating system properly.
- Switch the PC off.
- Check that the mouse cable is properly connected to the system unit.  
If you use an adapter or extension lead with the mouse cable, check the connections.
- Make sure that only one mouse is connected.
- Switch the PC on.

The mouse controller must be enabled if you use a PS/2 mouse on the PS/2 mouse port .

- Check in the BIOS Setup that the mouse controller is Enabled.
- Check that the mouse driver is properly installed and is present when the application programme is started. Detailed information can be found in the user guide for the mouse and application programme.

## **■ The Floppy Disk Cannot be Read or Written**

- Check that the floppy disk is not write protected.
- Check the relevant entries for Diskette A: or B: in the Main menu of the BIOS Setup.
- Check that the floppy disk drive controller is enabled.
- Check that the cables of the floppy disk drive are properly connected (refer to “Changing the floppy disk drive” chapter).

## ■ Time and/or Date is Not Correct

You can set the time and date in the BIOS Setup or in the operating system.

- Set the time and date.



---

If the time and date are repeatedly wrong when you switch on your PC, the on-board battery is flat. Change the lithium battery as described in the "Replacing lithium battery" chapter.

## ■ Tips

### **The PC cannot be switched off with the power button**

Cause: The PC was not switched on with the power button.

- Press the power button again.

Cause: System crash

- Press and hold the power button for at least four seconds until the device switches off.

### **Out of system resources**

If you have too many applications running at once, you may experience problems due to a lack of system resources. In this case you should:

- close unnecessary applications
- or
- run the applications in a different order.



**CD-ROM drive**

Information on the CD-ROM drive is contained:

- in the manual of the CD-ROM drive
- on the CD "Drivers & Utilities"

**Other manuals**

Other manuals are contained on the "Drivers & Utilities" CD.

# **CHAPTER 4**

---

---

## **System Expansion**

---

---

# 1 System Expansions



It may be necessary to update the BIOS when carrying out a system expansion or hardware upgrade. In this case, please contact our customer service centre.

When installing components with a high power loss, make sure that the maximum permissible temperatures of the individual components are not exceeded.

The device must be switched off when installing/removing the system expansions and may not be in the Suspend mode.

This chapter describes all the activities required to modify your PC hardware (e.g. installing boards or drives).

Memory and processor upgrading are described in the technical manual for the system board.

Read the supplied documentation before installing new drives and/or boards.

## ■ Information about boards

Take care with the locking mechanisms (catches and centring pins) when you are replacing the system board or components on the system board.

To prevent damage to the system board or the components and conductors on it, please take care when you insert or remove boards. Make sure expansion boards are inserted straightly.

Never use sharp objects (screwdrivers) for leverage.



Boards with electrostatic sensitive devices (ESD) are identifiable by the label shown.

When you handle boards fitted with ESDs, you must, under all circumstances, observe the following points:

- Some peripheral devices may not be used on your PC.
- You must always discharge static build up (e.g. by touching a grounded object) before working.
- The equipment and tools you use must be free of static charges.
- Remove the power plug from the mains supply before inserting or removing boards containing ESDs.
- Always hold boards with ESDs by their edges.
- Never touch pins or conductors on boards fitted with ESDs.

## ■ Opening the System Unit

- Switch the PC off. The PC must not be in the Suspend mode!

### ⚠ CAUTION

---

Please take note of the safety information in the "Important notes" chapter.  
Pull the power plug out of the mains outlet!

- If any cables attached to the system unit are obstructing you, pull out the connectors on the system unit.
- Place the system unit in a convenient working position.

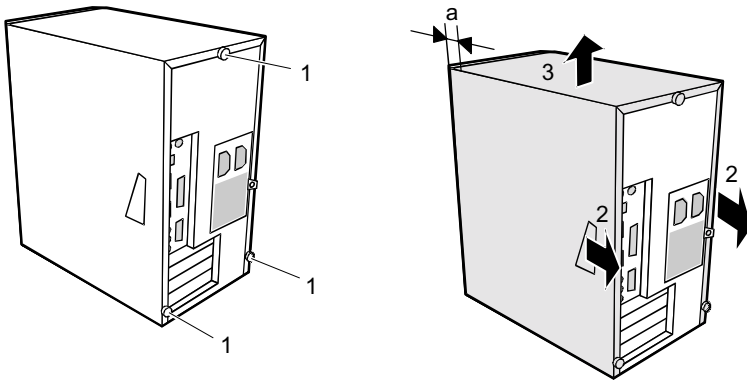

- 1 Loosen the screws (1).
- 2 Push the top cover in the direction of the arrow (2) until the distance (a) is approximately 10 mm.
- 3 Lift off the top cover in an upward direction (3).

## ■ Assembling the System Unit

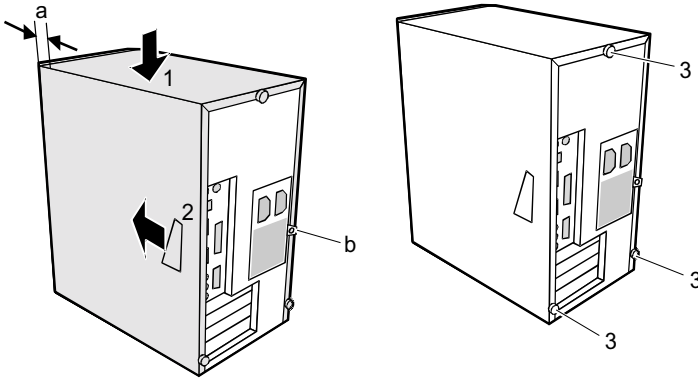

- 1 Place the top cover on the system unit in the direction of the arrow (1) so that the distance (a) is approx. 10 mm.
- 2 Push the top cover in the direction of the arrow (2).



Make sure that the eye (b) for the anti-theft protection fits in the recess on the top cover. Check whether the top cover is mounted straight.

- 3 Fasten the screws (3).
- 4 Return the system unit to its original position.
- 5 If you have disconnected cables, reconnect them to the connectors on the rear panel.

## ■ Installing and Removing a Board



### CAUTION

Please take note of the "Information about boards".

You can install boards which are up to 290 mm long.

The number, position and arrangement of the board slots on the system board can be found in the technical manual for the system board. Boards may already be installed when the device is shipped.

## ❑ Installing a board

- 1 Open the system unit (see "Opening the system unit").

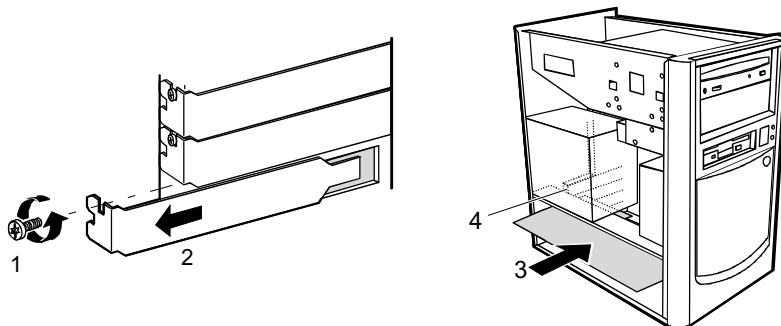

- 2 Remove the screw (1).
- 3 Remove the rear slot cover plate from the slot (2).



Do not dispose of the cover plate. For cooling, protection against fire and in order to comply with EMC regulations, you must refit the cover plate if you remove the board.

- 4 Take the new board out of its packaging.
- 5 Make the required settings for the board.
- 6 Push the board up to its slot (3).  
Ensure that the end of a long board without angle bracket fits into the corresponding guide of the system unit.
- 7 Press the board into the slot so that it engages.
- 8 Fix the board with the screw (4).
- 9 If necessary, connect the cables.
- 10 Close the system unit (see "Assembling the system unit").



If you have installed or removed a PCI board, please check the relevant PCI slot settings in the BIOS Setup. If necessary, change the settings. Further information is provided in the PCI board documentation.

## ❑ Removing a board

- 1 Open the system unit (see "Opening the system unit").
- 2 Disconnect the cables connected to the board.

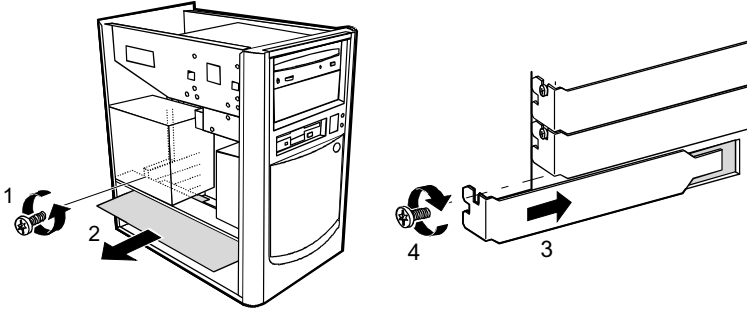

- 3 Remove the screw (1).
- 4 Remove the board from the system unit (2).
- 5 Place the board into appropriate packaging.

## ⚠ CAUTION

---

To ensure proper cooling, fire protection and observation of the relevant EMC (electromagnetic compatibility) regulations, you must mount a rear slot cover plate.

- 6 Push the rear slot cover plate into the slot (3).
- 7 Fasten the rear slot cover plate with the screw (4).
- 8 Close the system unit (see "Assembling the system unit").



---

If you have installed or removed a PCI board, please check the relevant PCI slot settings in the BIOS Setup. If necessary, change the settings. Further information is provided in the PCI board documentation.

## ■ Installing and Removing Drives

The system unit houses a total of three accessible drives (two 5 1/4-inch drives and one 3 1/2-inch drive) and one non-accessible half-height (Slimline) drive.

### IDE drives

By default four IDE drives are supported. Ideally hard disks are connected to IDE port 1, and accessible drives, for example CD-ROMs, to IDE port 2 (see also the Technical Manual for the system board).

### □ Installing an accessible drive

- 1 Open the system unit (see "Opening the system unit").

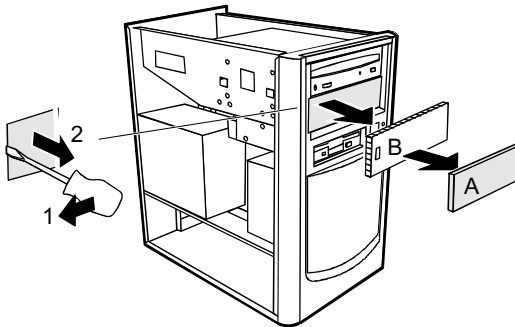

- 2 Pry the plastic drive cover (A) out of the front cover.
- 3 Pry the shielding plate (B) on left-hand side out of the bay.



Do not throw away the plastic covers. For cooling, protection against fire and in order to comply with EMC regulations, you must refit the plastic covers if you remove the drive again later.

- 4 Take the new drive out of its packaging.
- 5 Make the required changes to the drive settings (if necessary, to the settings of installed drives as well).



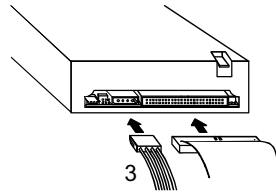
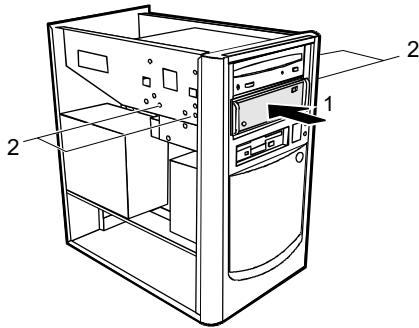

- 1 Slide the drive into the system unit (1).
- 2 Fasten the drive into place with the screws (2).
- 3 Plug the connectors of the data cable and the power supply cable into the drive (3). Make sure the polarity is correct.
- 4 Close the system unit (see "Assembling the system unit").



---

It may be necessary to modify the entry for the drive in the BIOS Setup.

❑ **Removing an accessible drive**

- 1 **Open the system unit (see "Opening the system unit").**

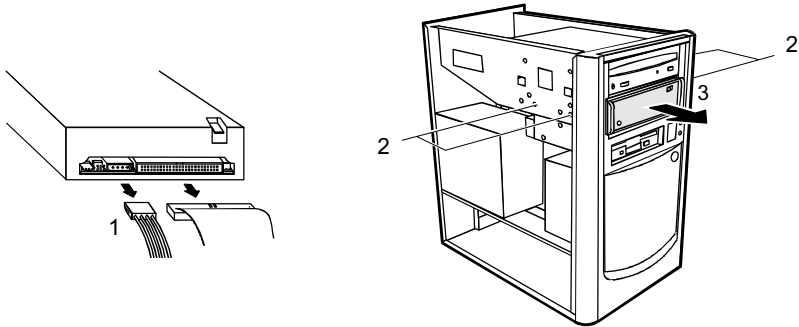

- 2 **Pull the data and the power supply connectors from the desired drive (1).**
- 3 **Remove the screws (2) and take the drive out of the system unit (3).**

**⚠ CAUTION**

For cooling, protection against fire and in order to comply with EMC regulations, you must refit the plastic cover.

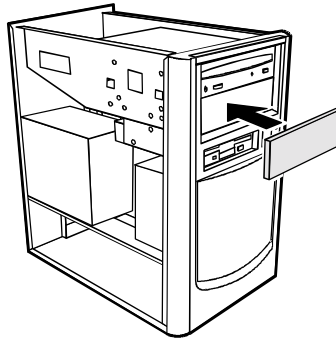

- 4 **Press the plastic drive cover into the front panel until it snaps in place.**
- 5 **Close the system unit (see "Assembling the system unit").**



It may be necessary to modify the entry for the drive in the BIOS Setup.

## ❑ Changing the floppy disk drive

- 1 Open the system unit (see "Opening the system unit").

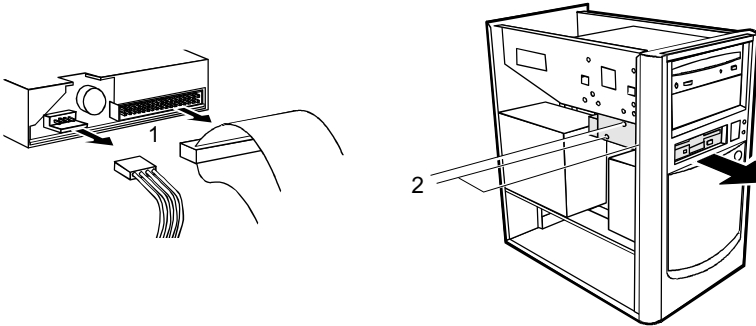

- 2 Pull the data and the power supply connectors from the floppy disk drive (1).
- 3 Remove the screws (2) on the left side of the floppy disk drive.

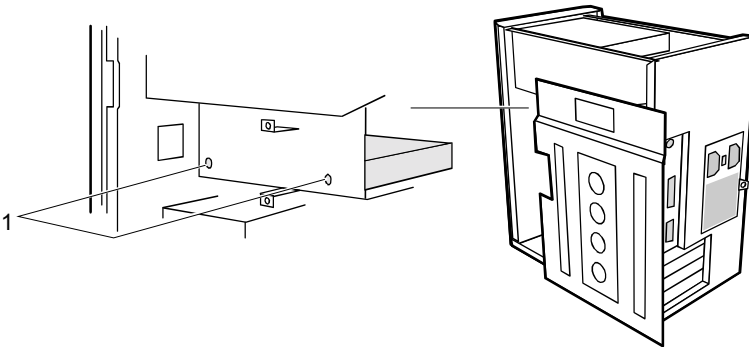

- 4 Remove the screws (1) on the right side of the floppy disk drive.



You may need to remove the USB front panel (see "Removing a USB front panel") before you can remove the screws on the right side of the floppy disk drive.

- 5 Slide the drive carrier out of the system unit in the direction of the arrow.

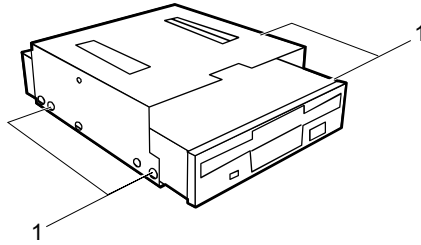

- 1 Remove the screws.
- 2 Take the new floppy disk drive out of its packaging.
- 3 Replace the floppy disk drive.
- 4 Fasten the drive with the screws.

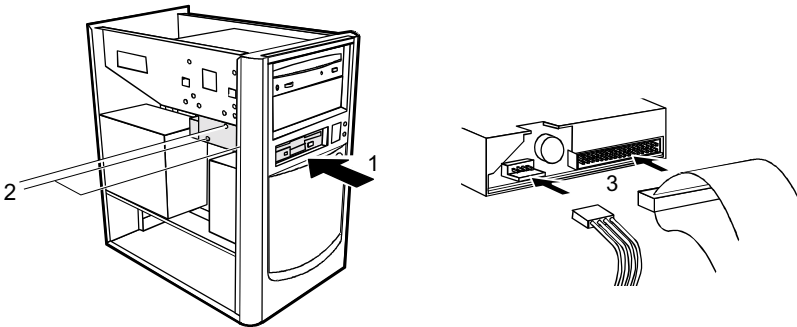

- 1 Slide the drive into the system unit (1).
- 2 Plug the connectors of the data cable and the power supply cable into the floppy disk drive (3).  
Make sure the polarity is correct.
- 3 Fasten the drive with the screw (2).
- 4 Close the system unit (see "Assembling the system unit").



It may be necessary to modify the entry for the drive in the BIOS Setup.

## ❑ Replacing a hard disk drive

### Removing the hard disk carrier

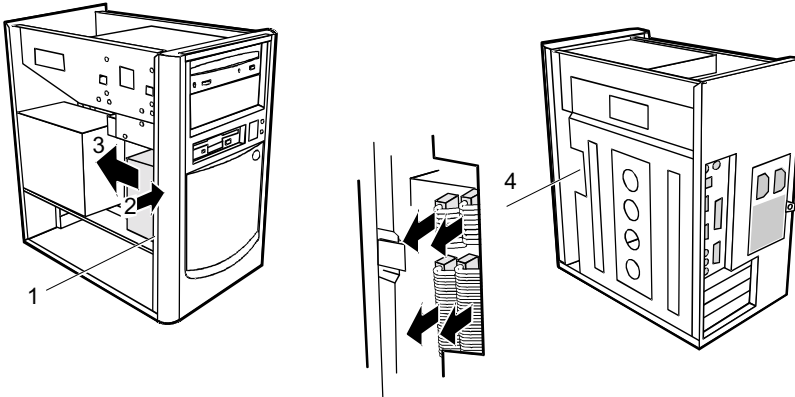

- 1 Open the system unit (see "Opening the system unit").
- 2 Remove the screw (1) and push the hard disk carrier in the direction of the arrow (2) out of its securing lugs.
- 3 Lift the hard disk carrier out of the system unit in the direction of the arrow (3).
- 4 Disconnect the cables from the hard disk drive (4).

### Replacing a hard disk drive

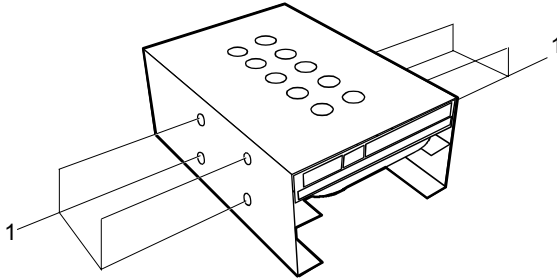

- 1 Remove the screws of the hard disk drive you want to replace.
- 2 Take the new hard disk drive out of its packaging.
- 3 Make the required settings (e.g. master/slave, stand alone) on the drives.
- 4 Replace the hard disk drive.
- 5 Fasten the hard disk drive with the screws.

### Replacing a hard disk drive

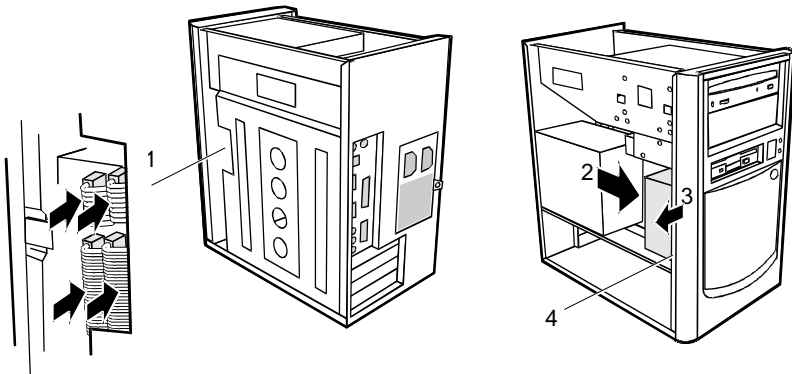

- 1 Connect the cables to the hard disk drive (1).
- 2 Insert the hard disk carrier in the guide rail provided for this purpose on the casing (2, 3).

- 3 Fasten the hard disk carrier with the screw (4).
- 4 Close the system unit (see "Assembling the system unit").



It may be necessary to modify the entry for the drive in the BIOS Setup.

#### Mounting a hard disk drive in a 5<sup>1</sup>/<sub>4</sub>" slot



To do this, you require a special mounting frame.

- 1 Open the system unit (see "Opening the system unit").
- 2 Make the required settings (e.g. master-slave) on the hard disk drives.

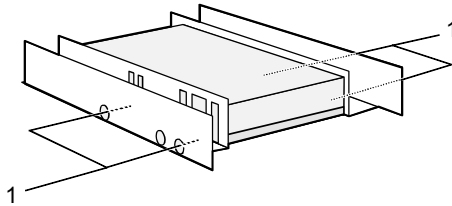

- 3 Fasten the drive with the four screws in the installation frame.
- 4 Install the installation frame with the drive in the desired 5<sup>1</sup>/<sub>4</sub>" slot (see "Installing an accessible drive").
- 5 Close the slot with the panel. Ensure that the cover engages.
- 6 Close the system unit (see "Assembling the system unit").

## □ Replacing lithium battery

### CAUTION

---

Incorrect replacement of the lithium battery may lead to a risk of explosion.

The lithium battery may be replaced only with an identical battery or with a type recommended by the manufacturer.

Do not throw lithium batteries into the household waste. They must be disposed of in accordance with local regulations concerning special waste.

Ensure that you insert the battery the right way round. The plus pole must be on the top!

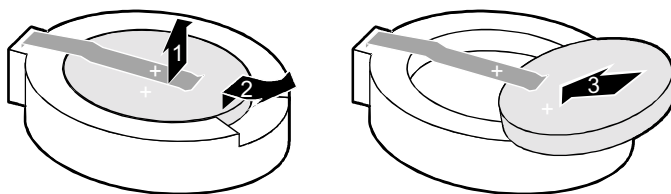

- 1 Lift the contact (1) a few millimetres and remove the lithium battery from its socket (2).**
- 2 Insert a new lithium battery of the same type into the socket (3).**



- **Replacing processor**

To replace the processor you must remove the system board bracket.

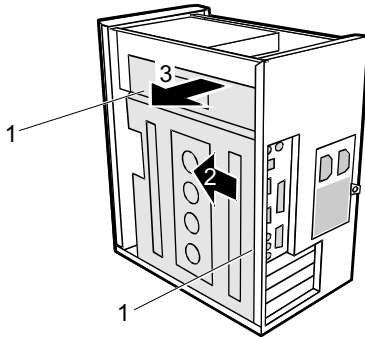

- 1 **Open the system unit (see "Opening the system unit").**
- 2 **Remove all boards (see "Removing a board").**
- 3 **Unscrew the screw on the system board rack (1), push the system board rack somewhat in the direction of the arrow (2) and then tilt it out upward (3).**

Replace the processor.

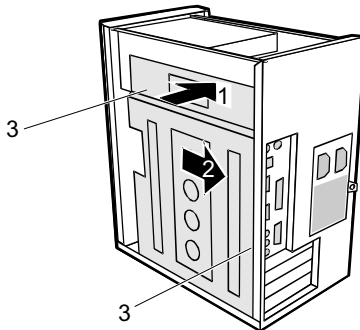

- 1 **Fold the system board rack into the casing again (1) and push it back into its original position (2).**
- 2 **Fasten the screw (3).**
- 3 **Reinstall all boards (see "Installing a board ").**
- 4 **Close the system unit (see "Assembling the system unit").**

# **CHAPTER 5**

---

## **Technical Data**

---

# 1 Technical Data

## ■ Electrical Data

Product Name	DESKPOWER 2000	
Regulations complied with:	IEC 60950 / VDE 0805, UL 1950 CSA 22.2 No.950	
Protection class:	I	
Rated voltage range: (selectable)	100 V - 127 V / 200 V - 240 V	
Frequency:	50 Hz - 60 Hz	
Max. rated current	<u>Power supply 110 W</u>	<u>Power supply 200 W</u>
• System unit with monitor socket:	100 V - 127 V / 5,5 A 200 V - 240 V / 3,0 A	7,0 A 3,5 A
• Monitor socket (output):	100 V - 127 V / 3 A 200 V - 240 V / 1,5 A	3,0 A 1,5 A
Max. power draw in operation (peak):	136 W *	
Min. power draw in operation:	48 W *	
Power draw in energy saving mode (ACPI-S3 mode):	2,5 W *	
Power draw in 'ready-to-operate' mode (ACPI-S3 mode):	2,9 W *	
Noise emission		
• Sound pressure $L_{pAm}$ (Idle mode):	28 dB *	
• Sound power level $L_{WAd}$ (Operation mode):	45 dB *	
• Sound power level $L_{WAd}$ (Idle mode):	42 dB *	

\*) These values only apply for a SCENIC T with the configuration below. Installing additional components can cause the specified values for power draw and sound emission to be exceeded.

Processor (256 KB cache):	Pentium 4 Prozessor 2 GHz
Main memory:	128 Mbyte SDRAM
Floppy disk drive:	1,44 Mbyte
Hard Disk unit:	40 Gbyte, 7200 rpm
CD-ROM drive:	48fach
Graphics:	GM3000-16, Nvidia
Audio:	AD1885 AC'97, onboard
LAN:	Intel 8256ZET Ethernet Controller
Dimensions	
Width/depth/height:	196 mm/350 mm/360 mm
Weight	
with the basic configuration:	ca. 8 kg (78,5 N) in basic configuration
Environmental conditions	
Environment class 3K2	DIN IEC 721 part 3-3
Environment class 2K2	DIN IEC 721 part 3-2
Temperature:	
• Operating (3K2)	15 °C .... 35 °C
• Transport (2K2)	-25 °C .... 60 °C
Condensation in operating must be avoided.	
Clearance required to ensure adequate ventilation:	
• left	min. 200 mm
• front	min. 200 mm
• rear	min. 200 mm

## ■ List of Specifications

Model	DESKPOWER 2000
CPU	Intel Pentium 4 Processor 1.8-2.2 GHz
Secondary Cache	256 KB for CPU below 2.0 GHz, 512 KB for CPU 2.0 GHz and above
System Bus Clock	400 MHz
Memory	128MB SDRAM w/ECC, Max 1.5GB (512MB DIMM×3, PC133 Supported)
Flash ROM	512 KB Flash Memory
Chipset	Intel 845
Architecture	AGP/PCI
Floppy Drive	3.5", 1.44 MB
Hardisk Drive (EIDE)	80/40/20 GB (Ultra ATA/100 and S.M.A.R.T support)
Optical Devices	Optional: 48 × CD-ROM or CD-R/RW (40×/16×/10×) or Combo Drive [DVD: 8×/DVD-R: 2× & CD-R/W (32×/8×/8×)]
Graphics	Standard: – ATI RADEON VE16MB DDR Optional: nVIDIA GeForce3 64MB DDR
Sound	Analog Devices AD1885 (AC97 CODEC) + ICH2
Network Interface	Intel 82562ET 10/100 Mbps BASE-T (Integrated) Supports:- Wake-on LAN
Advanced Manageability	Optional: DeskView *
I/O Interface	Serial Port (RS232C)×2 Parallel Port (EPP/ECP)×1 USB×2 (Rear) PS/2 Keyboard Port×1 PS/2 Mouse Port×1 Audio (Rear: Line-in×1, Line-out×1, Mic-in×1) Video (Analog, D-sub 15)×1 RJ45×1
Expansion Slots (Free)	PCI×3 [3] AGP×1 [0]
Drive Bays (Free)	Front Access: 3.5"×1 [0], 5.25"×2 [2] Internal: 3.5"×2 [1]
Display	Fujitsu 15" Color Monitor Optional: Fujitsu 17" Color Monitor or Fujitsu 15" XGA TFT LCD Panel
Housing	Micro-Tower
OS Bundled	Microsoft Windows XP Home
Power Management	ACPI
Power Supply	110/230V AC, 50/60 Hz
Dimensions	Approx. 196 mm(W) × 350 mm (D) × 361 mm (H)
Weight	Approx. 9.5 kg

\* Not supported under Windows 98, Windows ME and Windows NT Workstation environment

# Index

## A

Accessible drive	
installing .....	33
removing .....	35
Alt key .....	16
Anti-theft protection .....	18
Audio input .....	9
Audio output .....	9

## B

Battery .....	41
disposal .....	xi
BIOS Setup .....	18
security functions .....	19
settings .....	18
system settings .....	18
Blank monitor .....	23
Board .....	28
installing .....	31
removing .....	32

## C

Cable	
connecting .....	8
disconnecting .....	8
Casing	
closing .....	30
opening .....	29
CD-ROM drive	
indicator .....	14
installing .....	33
manual .....	26
removing .....	35
CE marking .....	xi
Chain .....	18
Class B Compliance Statement .....	ix
Cleaning .....	x
Clearance .....	44
Configuration, BIOS Setup .....	18
Connecting	
keyboard .....	3
mouse .....	4

parallel port .....	10
serial port .....	10
standard keyboard .....	3
Contents of delivery .....	2
Ctrl key .....	16
Cursor keys .....	16

## D

Data	
technical .....	44
Data protection .....	18
Date	
not correct .....	25
Device drivers .....	10
Devices	
connecting .....	8, 10
ports .....	9
Dimensions .....	45
Diskette .....	17
Drive	
accessible	
installing .....	33
removing .....	35
hard disk	
installing .....	38, 39

## E

Electrical data .....	44
Electromagnetic compatibility .....	xi
Energy saving .....	viii
Enter key .....	16
Environmental conditions .....	44
Error	
date .....	25
floppy disk .....	24
mouse .....	24
system unit .....	22
time .....	25
Expansion .....	28
External devices	
connecting .....	8, 10
ports .....	9

<b>F</b>	
FCC statement .....	ix
First time switching on .....	6
Flashing power-on indicator .....	14
Floppy disk	
cannot read .....	24
cannot write .....	24
write-protection .....	17
Floppy disk drive	
changing .....	36
indicator .....	14
removing .....	36
Function keys .....	15
<b>G</b>	
Game port .....	9
<b>H</b>	
Hard disk drive	
mounting .....	40
replacing .....	39
Hard disk indicator .....	14
Headphones .....	9
<b>I</b>	
IDE drives .....	33
Important notes .....	viii
Indicator	
power-on indicator	
green .....	14
orange .....	14
system unit .....	14
Installing	
software .....	6, 7
Interfaces .....	9
<b>K</b>	
Kensington Lock .....	18
Keyboard .....	15
connecting .....	3
Keyboard port .....	3, 9
<b>L</b>	
LAN port .....	9
Line in .....	9
Line out .....	9
Lithium battery	
replacing .....	41
<b>M</b>	
Microphone jack .....	9
Monitor	
cleaning .....	x
remains blank .....	23
switching on .....	6
transporting .....	x
Monitor port .....	3, 9
Mouse	
connecting .....	4
error .....	24
Mouse pointer .....	24
Mouse port .....	3, 9
<b>N</b>	
New installation, software .....	22
No picture .....	23
Noise level .....	44
Notational conventions .....	vii
Note	
boards .....	28
CE certificate .....	xi
disposal .....	xi
energy saving .....	viii
important .....	viii
manufacturer .....	viii
safety .....	viii
Num Lock key .....	16
Numeric keypad .....	16
<b>O</b>	
Operating, PC .....	12
Other manuals .....	26
Overview, PC .....	xiii
<b>P</b>	
Parallel port .....	9, 10
connecting devices .....	10
settings .....	10
PC	
assembling .....	30
cabling .....	8
cannot be switched on .....	22

cleaning .....	x
connecting devices .....	8
indicators .....	14
opening .....	29
ports .....	9
setting up .....	3
switching off .....	13
devices with main power switch .....	13
devices without main power switch .....	13
switching on .....	6, 13
switching on for the first time .....	6
transporting .....	x
Power switch .....	11, 25
Power management .....	26
Power-on indicator .....	14
Preparing for use .....	2
Printer .....	9
Processor .....	45
Property protection .....	18
PS/2 mouse port .....	3, 4, 9
PS/2 mouse, connecting .....	4
<b>R</b>	
Rated voltage	
Devices with main power switch .....	5
Devices without main power switch .....	5
Recycling .....	xi
Retransportation .....	x
<b>S</b>	
Safety .....	viii
SCSI port .....	9
Security functions	
BIOS Setup .....	18
MS-Windows .....	18
Security measures .....	18
Serial port .....	9, 10
connecting devices .....	10
settings .....	10
Setup, see BIOS Setup .....	18
Software	
installing .....	6, 7
new installation .....	22

Standard keyboard, connecting .....	3
Symbols, explanation of .....	vii
System expansion .....	28
System settings, BIOS Setup .....	18
System unit	
trouble .....	22
System unit, see PC	

<b>T</b>	
Technical data .....	44
Time	
daylight savings .....	25
not correct .....	25
Transport .....	x
Trouble	
floppy disk .....	24
mouse .....	24
screen .....	23
Troubleshooting .....	22

<b>U</b>	
Unpacking .....	2
USB mouse, connecting .....	4
USB port .....	3, 4
USB, Universal Serial Bus .....	3, 9

<b>V</b>	
Ventilation area .....	44

<b>W</b>	
Weight .....	45
Write protection, floppy disk .....	17