



**XL 1500 WASH**

**PR-2805/PR-2805M**

This product manual contains important information about the safe installation and use of this projector. Please read and follow these instructions carefully and keep this manual in a safe place for future reference.

PR LIGHTING LTD.  
<http://www.pr-lighting.com>

## INDEX

SAFE USAGE OF THE PROJECTOR	3
INSTALLING THE PROJECTOR	4
FITTING THE LAMP	4
POWER SUPPLY – MAINS	5
CONTROL CONNECTIONS	5
DMX TERMINATOR	6
SETUP OPTIONS-PROJECTOR CONFIGURATION	6
TO SET THE DMX START ADDRESS	6
OPERATION MENU	7
ERROR MESSAGES	10
DMX PROTOCOL	11
LED INDICATION	14
MAINTENANCE	14
LUBRICATION	14
KEEPING THE PROJECTOR CLEAN	14
TROUBLESHOOTING	15
TECHNICAL DATA	16
ELECTRICAL DIAGRAM	19
COMPONENT ORDER CODES	20

Please note that as part of our ongoing commitment to continuous product development, specifications are subject to change without notice. Whilst every care is taken in the preparation of this manual we reserve the right to change specifications in the course of product improvement. The publishers cannot be held responsible for the accuracy of the information herein, or any consequence arising from them.

Every unit is tested completely and packed properly by the manufacturer. Please make sure the packing and / or the unit are in good condition before installation and use. Should there be any damage caused by transportation, consult your dealer and do not use the unit. Any damage caused by improper use will not be assumed by the manufacturer and / or dealer.

## ACCESSORIES

These items are packed together with the projector:

Name	Quantity	Unit	Remark
G clamps	2	Pcs	
XLR cable	1	Pc	3-pin plug
Safety cords	2	Pcs	
This manual	1	Pc	
Ω clamps	2	Pcs	Options

## SAFE USAGE OF THE PROJECTOR



When unpacking and before disposing of the carton check there is no transportation damage before using the projector. Should there be any damage caused by transportation, consult your dealer and do not use the apparatus.

The projector is for indoor use only, IP20. Use only in dry locations. Keep this device away from rain and moisture, excessive heat, humidity and dust. Do not allow contact with water or any other liquids.

The projector is not designed or intended to be mounted directly on to inflammable surfaces. 

The projector is only intended for installation, operation and maintenance by qualified personnel.

The projector must be installed in a location with adequate ventilation, at least 50cm from adjacent wall surfaces. Be sure that no ventilation slots are blocked.

Do not project the beam onto inflammable surfaces, minimum distance is 5m.  5m 

Avoid direct exposure to the light from the lamp. The light is harmful to the eye.

Do not attempt to dismantle and/or modify the projector in any way.

Electrical connection must only be carried out by qualified personnel.

Before installation, ensure that the voltage and frequency of power supply match the power requirements of the projector.

It is essential that each projector is correctly earthed and that electrical installation conforms to all relevant standards.

Do not connect this device to any other types of dimmer apparatus.

Make sure that the power-cord is never crimped or damaged by sharp edges. Never let the power-cord come into contact with other cables. Only handle the power-cord by the plug. Never pull out the plug by tugging the power-cord.

Keep the lamp clean. Do not touch the lamp glass with bare hand.

The projector should always be installed with a secondary safety fixing. A safety cord is supplied for this; it should be attached as shown in "installing the projector" section.

The lamp used in this projector is a discharge lamp. After switching off don't attempt to restart the projector until lamp has cooled, this will require approx 15 minutes. Switching the lamp on and off at short intervals will reduce the life of both the lamp and the projector. But occasional breaks will prolong the life of the lamp and projector.

Never run the projector without a lamp.

There is no user serviceable parts inside the projector, do not open the housing and never operate the projector with the covers removed.

**Always disconnect from the mains, when the device is not in use or before cleaning it or before attempting any maintenance work !**

If you have any questions, don't hesitate to consult your dealer or manufacturer.

## INSTALL THE PROJECTOR

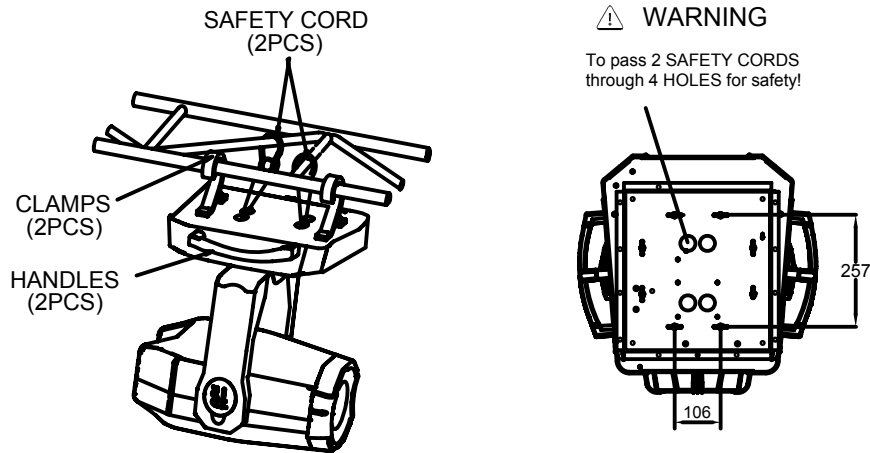

Take 2 clamps and 2 safety cords out from the package and mount 2 clamps on the underside of fixture with 4 retainers attached to each clamp. Hang the fixture on the structure and fasten the screws attached to each clamp. (See the **WARNING** on the underside of the base as shown above) **To pass 2 SAFETY CORDS through 4 HOLES for safety!** Always ensure that the projector is firmly anchored to avoid vibration and slipping whilst functioning. Always ensure that the structure that you are going to mount the projector is secure and is strong enough to support a weight of XL WASH 1500.

**WARNING:**

1. Unlock the PAN and TILT before the 1<sup>st</sup> application of projector for safety.
2. The projector **MUST** be lifted or carried by the HANDLES instead of clamps.
3. For safety the safety cord should afford 10 times of the unit's weight.

## FITTING THE LAMP

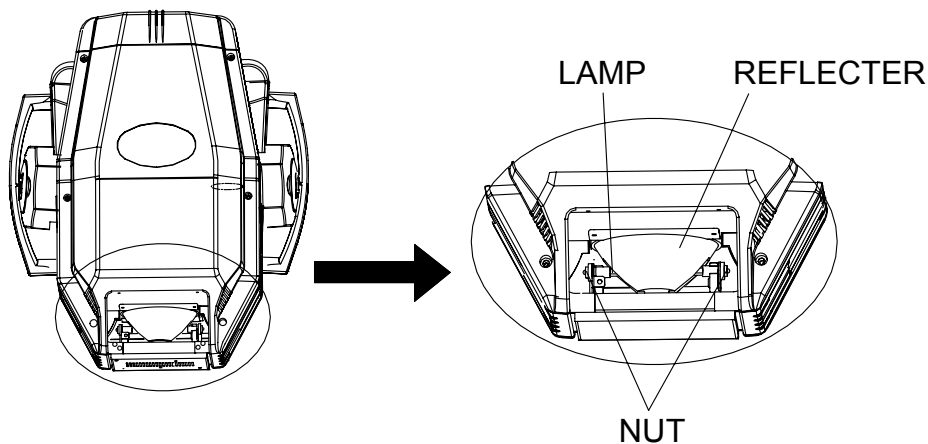

Lock the yoke before fitting/replacing the lamp.

Loosen 4 screws and open the back covers, you can see the structure as shown in the figure above.

Loosen 2 nuts at the both ends of lamp and take out the worn-out lamp. Suggest to free one end after another.

Fit new lamp and fasten 2 screws at the both ends of lamp. **Note:** don't touch the bulb of the new lamp with bare hand so as not to influence the beam output; the PST (pumping stem tip off) on the bulb facing the rear cover with fans perpendicularly and being not in the beam's way is a must and aids cooling.

Close the rear cover and fasten 4 screws.

**NOTE:** The convex of the nuts should face to the side when fitting the lamp.

**WARNING:** The MSR series are high-pressure lamps with external igniters (⚠). Care should always be taken when handling these lamps. Always read the manufacturers "Instructions for use" enclosed with the lamp.

## POWER SUPPLY-MAINS

Connect the power cord as follows:

- L (live) =brown
- E (earth) =yellow/green
- N (neutral) =blue

Use the plug provided to connect the mains power to the projector paying attention to the voltage and frequency marked on the panel of the projector. It is recommended that each projector be supplied separately so that they may be individually switched on and off.

### IMPORTANT

**It is essential that each projector is correctly earthed and the electrical installation conforms to all relevant standards.**

## CONTROL CONNECTION

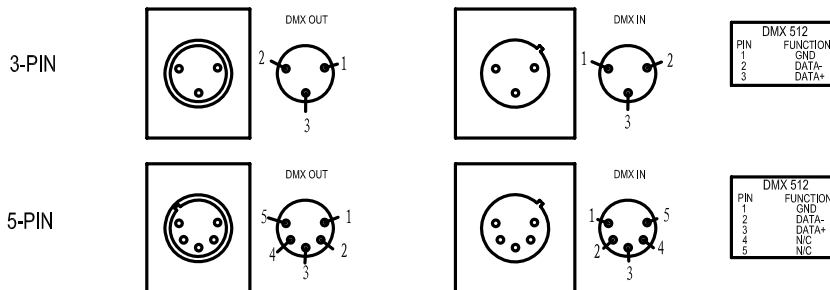

Connection between controller and projector and between one projector and another must be made with a 2 core-screened cable, with each core having at least a 0.5mm diameter. Connection to and from the projector is via cannon 3 pin (which are included with the projector) or 5 pin XLR plugs and sockets. The XLR's are connected as shown in the figure above.

Note: care should be taken to ensure that none of the pins touch the metallic body of the plug or each other. The body of the plug is not connected in any way. The XL WASH 1500 accepts digital control signals in protocol DMX512 (1990).

Connect the controller's output to the first fixture's input, and connect the first fixture's output to the second fixture's input and connect the rest fixtures in the same way. Eventually connect the last fixture's output to a DMX terminator as shown in the figure below.

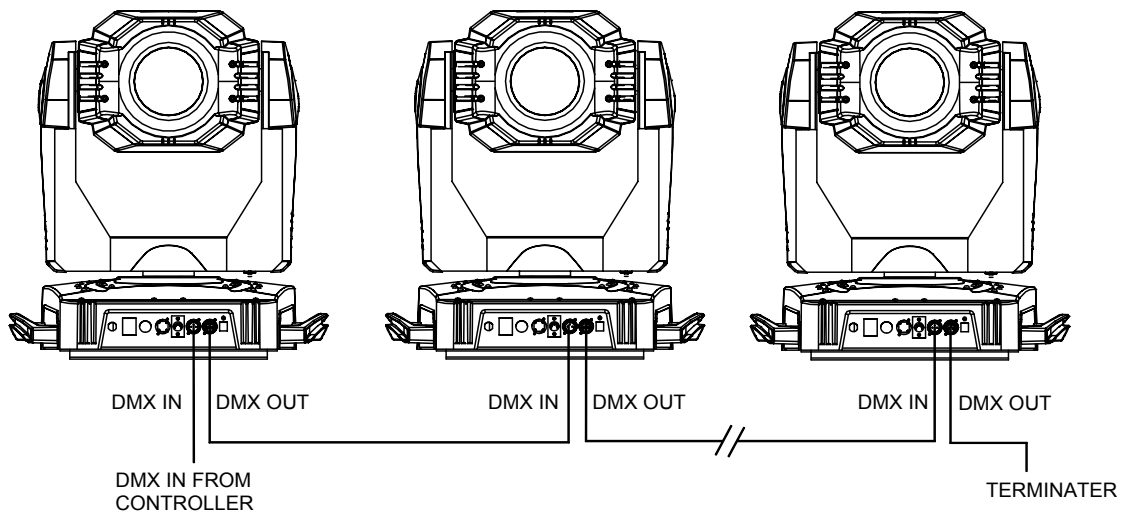

## DMX TERMINATOR

In the Controller mode, at the last fixture in the chain, the DMX output has to be connected with a DMX terminator. This prevents electrical noise from disturbing and corrupting the DMX control signals.

The DMX terminator is simply an XLR connector with a 120Ω (ohm) resistor connected across pins 2 and 3, which is then plugged into the output socket on the last projector in the chain. The connections are illustrated below.

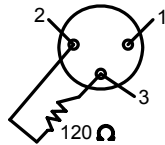

DMX TERMINATOR  
CONNECTION

Connect a 120Ω(OHM) resistor  
across pins 2 and 3 in an XLR plug  
and insert into the DMX out socket  
on the last unit in the chain.

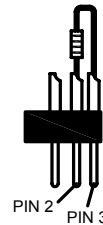

## SETUP OPTIONS-PROJECTOR CONFIGURATION

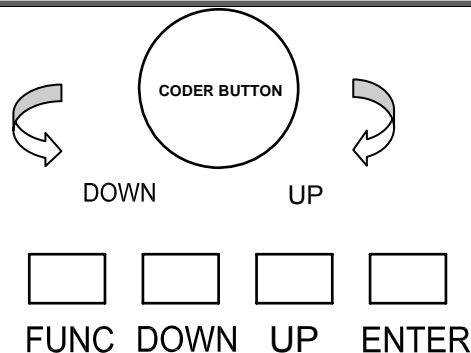

Projector configuration can be set conveniently via pressbutton switch and LCD display. Turn the projector on and the LCD display will show DMX address you set and save last time and it can be reset and saved again as you please.

Launch the projector. Press button **ENTER** more than 5 seconds to unlock panel.

Press button **UP** or **DOWN** if you want to browse through the various Setup Options. There are 8 option codes from **DMX Address** to **Lamp Manual Control**, and each code has a specific function. If you turn the coder knob clockwise, the function like as button **UP**. On the contrary, the function like as button **DOWN**.

Press button **ENTER** to save your settings or enter the next menu. There is same function if you push the coder knob.

Press button **UP** or **DOWN** to shift.

Press button **FUNC**, it will return to the upper menu one by one. If you stay for minutes defaulted will show display status automatically.

## TO SET THE DMX START ADDRESS

Each XL WASH 1500 must be given a DMX start address so that the correct projector responds to the correct control signals. This DMX start address is the channel number from which the projector starts to “listen” to the digital control information being sent out from the controller. The XL WASH 1500 has 3 DMX modes. There are standard mode, extended mode and short mode. For example standard mode has 17 channels, so set the No. 1 projector’s address 001, No. 2 projector’s address 018, No. 3 projector’s address 035, No. 4 projector’s address 052, and so on.

Launch the projector. Press button **ENTER** or coder knob more than 5 seconds to unlock panel.

Press button **FUNC** to display **DMX address**;

Press button **UP** and **DOWN**, you can set the address;

Press button **ENTER** to confirm; In the same time. The GREEN LED will flash one time. It means the setting has been enabled.

Press button **FUNC**, it will return to the upper menu one by one.

## OPERATION MENU

1st LEVEL	2nd LEVEL	3rd LEVEL	4th LEVEL	
PR LIGHTING XL SERIES XL 1500 WASH	DMX Address=001			
DMX Address	DMX Address 001-499 in short mode 001-496 in stand mode 001-490 in extended mode			
Reset	Reset Are You Sure?			
Config Settings	DMX Mode	DMX Mode Standard 16		
		DMX Mode Extended 16		
		DMX Mode Short 8		
	Lamp Control	Lamp Control By Control Channel		
		Lamp Control By Power On		
		Lamp Control By DMX Present		
	Loss of DMX	When DMX is Lost Normal Time Out		
		When DMX is Lost Hold Last Value		
	Factory Settings (Press button <b>DOWN/UP/ENTER</b> at the same time to enter the sub-menu)	<b>(WARNING: Never change the fixture type or the system will be damaged!)</b>	Fixture type= XL 1200	
			Fixture type= XL 700	
			Fixture type= XL 575	
			Fixture type= XL 1200 FS	
			Fixture type= XL 1200 Wash	
			Fixture type= XL 700 Wash	
			Fixture type= XL 1800	
Fixture type= XL 1500				
Fixture type= XL 1500 Wash				
Fixture type= XS 1200				
Option Settings	Colour Positions	Colour Positions STEPPED		
		Colour Positions LINEAR		
	Pan DMX Invert	Pan DMX Invert OFF		
		Pan DMX Invert ON		
	Tilt DMX Invert	Tilt DMX Invert OFF		
		Tilt DMX Invert ON		
	Pan Tilt Swap	Pan Tilt Swap OFF		
		Pan Tilt Swap ON		
	Dimmer Invert	Dimmer Invert OFF		
		Dimmer Invert ON		
	Zoom Invert	Zoom Invert OFF		
		Zoom Invert		

		ON		
	CMY Invert	CMY Invert OFF		
		CMY Invert ON		
	CTO Invert	CTO Invert OFF		
		CTO Invert ON		
	Defaults	Defaults OFF		
		Defaults Restore Defaults		
Display Options	Display Mode	Display On Always		
		Display Off After Delay		
	Display Invert	Display Invert OFF		
		Display Invert ON		
	Display Dimming	Disp Dim Level Min		
		Disp Dim Level 1		
		Disp Dim Level 2		
		Disp Dim Level 3		
		Disp Dim Level 4		
		Disp Dim Level 5		
		Disp Dim Level 6		
		Disp Dim Level 7		
		Disp Dim Level 8		
		Disp Dim Level 9		
	Disp Dim Level Full			
	Display Contrast	Display Contrast XXX(1~36, Default is 16)		
Display Language	Language = English			
	Language = Chinese			
Information	Lamp Hours	Lamp Hours = XX	Reset Lamp Hours Are You Sure?	
	Total Hours	Total Hours = XX		
	Temperature	Display Board	Display Board = XX°C	
		Driver Board 1	Driver Board 1 = XX °C	
		Driver Board 2	Driver Board 2 = XX °C	
		Pan and Tilt	Pan and Tilt = XX °C	
		Head Sensor	Head Sensor= XX °C	
	Software Version	Display Board	Display Board = X.X.X	
		Driver Board 1	Driver Board 1 = X.X.X	
		Driver Board 2	Driver Board 2 = X.X.X	
Pan and Tilt		Pan and Tilt = X.X.X		
Power Board		Power Board = X.X.X		
View DMX values	DMX Channel 1=0			



Test Modes	Factory Setup	Factory Setup OFF	
		Factory Setup ON	
	Self Test	Self Test OFF	
		self test ON	
Lamp Manual Control	Lamp Status	Status = XXX Control = X	
	Turn Lamp On		
	Turn Lamp Off		

## ERROR MESSAGES

In the course of launch, XL WASH 1500 examines automatically whether there are errors and if there are, it will display information as follows:

Display	Message
Sensor Err S1-M1	Colour wheel 1 (1# drive board motor 1) error
Sensor Err S1-M2	CTO (1# drive board motor 2) error
Sensor Err S1-M3	CYM-cyan (1# drive board motor 3) error
Sensor Err S1-M4	CYM-yellow (1# drive board motor 4) error
Sensor Err S1-M5	CYM-magenta (1# drive board motor 5) error
Sensor Err S1-M6	Dimmer (1# drive board motor 6) error
Sensor Err S2-M1	Zoom (2# drive board motor 1) error
Sensor Err S2-M2	Inside lens 1 (2# drive board motor 2) error
Sensor Err S2-M3	Inside lens 2 (2# drive board motor 3) error
Sensor Err S2-M4	Colour wheel 2 (2# drive board motor 4) error
Sensor Err S2-M5	Strobe 1 (2# drive board motor 5) error
Sensor Err S2-M6	Strobe 2 (2# drive board motor 6) error

## DMX PROTOCOL

Short mode	Standard mode	Extended mode	FUNCTION	DMX	DESCRIPTION
1	1	1	Strobe	000-010	Black
				011-025	Open
				026-225	Strobe speed from slow to fast
				226-255	Open
2	2	2	Dimmer	000-007	Black
				008-255	Dimming from dark to light (0-100%)
		3	Dimmer Fine	000-255	Dimmer in 16 Bit precision
3	3	4	CYM Macro	000-016	White
				017-035	Yellow+ Magenta=Red
				036-054	Yellow
				055-073	Yellow+ Cyan=Green
				074-092	Cyan
				093-110	Cyan+ Magenta=Blue
				111-128	Magenta
129-255	CYM colour mixing from slow to fast				
4	4	5	CYM-Cyan	000-255	Cyan (Linear 0-100%)
		6	CYM-Cyan Fine	000-255	Cyan in 16 Bit precision
5	5	7	CYM-Yellow	000-255	Yellow (Linear 0-100%)
		8	CYM-Yellow Fine	000-255	Yellow in 16 Bit precision
6	6	9	CYM-Magenta	000-255	Magenta (Linear 0-100%)
		10	CYM-Magenta Fine	000-255	Magenta in 16 Bit precision
7	7	11	CTO	000-255	Linear adjust from high to low
		12	CTO Fine	000-255	CTO in 16 Bit precision
8	8	13	Colour Wheel 1	000-016	White
				017-024	White/colour 1
				025-032	Colour 1
				033-040	Colour 1/colour 2
				041-048	Colour 2
				049-056	Colour 2/colour 3
				057-064	Colour 3
				065-072	Colour 3/colour 4
				073-080	Colour 4
				081-088	Colour 4/colour 5
				089-096	Colour 5
				097-104	Colour 5/colour 6
				105-112	Colour 6
				113-120	Colour 6/ white
				121-127	white
128-133	Rainbow rotation speed 1 (slowest)				
134-139	Rainbow rotation speed 2				

				140-145	Rainbow rotation speed 3
				146-151	Rainbow rotation speed 4
				152-157	Rainbow rotation speed 5
				158-163	Rainbow rotation speed 6
				164-169	Rainbow rotation speed 7
				170-175	Rainbow rotation speed 8
				176-181	Rainbow rotation speed 9
				182-187	Rainbow rotation speed 10
				188-195	Stop in current position
				196-201	Rainbow reverse rotation speed 1 (slowest)
				202-207	Rainbow reverse rotation speed 2
				208-213	Rainbow reverse rotation speed 3
				214-219	Rainbow reverse rotation speed 4
				220-225	Rainbow reverse rotation speed 5
				226-231	Rainbow reverse rotation speed 6
				232-237	Rainbow reverse rotation speed 7
				238-243	Rainbow reverse rotation speed 8
				244-249	Rainbow reverse rotation speed 9
				250-255	Rainbow reverse rotation speed 10
9	9	14	Colour Wheel 2	000-016	White
				017-024	White/colour 1
				025-032	Colour 1
				033-040	Colour 1/colour 2
				041-048	Colour 2
				049-056	Colour 2/colour 3
				057-064	Colour 3
				065-072	Colour 3/colour 4
				073-080	Colour 4
				081-088	Colour 4/colour 5
				089-096	Colour 5
				097-104	Colour 5/colour 6
				105-112	Colour 6
				113-120	Colour 6/ white
				121-127	white
				128-133	Rainbow rotation speed 1 (slowest)
				134-139	Rainbow rotation speed 2
				140-145	Rainbow rotation speed 3
				146-151	Rainbow rotation speed 4
				152-157	Rainbow rotation speed 5
158-163	Rainbow rotation speed 6				
164-169	Rainbow rotation speed 7				
170-175	Rainbow rotation speed 8				
176-181	Rainbow rotation speed 9				
182-187	Rainbow rotation speed 10				

				188-195	Stop in current position
				196-201	Rainbow reverse rotation speed 1 (slowest)
				202-207	Rainbow reverse rotation speed 2
				208-213	Rainbow reverse rotation speed 3
				214-219	Rainbow reverse rotation speed 4
				220-225	Rainbow reverse rotation speed 5
				226-231	Rainbow reverse rotation speed 6
				232-237	Rainbow reverse rotation speed 7
				238-243	Rainbow reverse rotation speed 8
				244-249	Rainbow reverse rotation speed 9
				250-255	Rainbow reverse rotation speed 10
10	10	15	Zoom	The DMX value of narrow angle channel is 0	
				000-255	Linear adjust from 15° to 42°
				The DMX value of narrow angle channel is not 0	
				000-009	Narrow angle mode
		16	Zoom Fine	000-255	Zoom in 16 precision
11	11	17	Narrow Angle	This channel is available only with DMX value of zoom channel is between 000-009	
				000-255	Open the inside Zoom lens, change beam angle to 10°
12	12	18	Pan	000-255	Pan rotation 450°
	13	19	Pan Fine	000-255	Pan rotation in 16 precision
13	14	20	Tilt	000-255	Tilt rotation 270°
	15	21	Tilt Fine	000-255	Tilt rotation in 16 precision
	16	22	Pan & Tilt speed	000-255	Pan&Tilt speed from fast to slow
14	17	23	Control	000-048	Reserved
				049-080	Reset
				081-112	Reserved
				113-144	Lamp off ( stop in DMX value for 10 s)
				145-168	Reserved
				169-200	Lamp power reduced to 50%
				201-223	Reserved
224-255	Lamp on (See remark below)				

**Remark:**

If you intend to turn on/off the lamp via the last channel of the controller, don't attempt to push the channel to value 224-255 immediately after turning it off, or push the slide bar to value 224-255 to wait it cooling. Under these 2 circumstances, the lamp can not be turned on. The right operation is: turn it off—cool down—push the slide bar to turn it on.

## LED INDICATION

Green	On	DMX signal OK
	Off	No DMX signal
	Flash	DMX signal error
Yellow	On	Setting the panel
Blue	On	Power
Red/Green	Red	Running self test mode
	Green	Reserved

## MAINTENANCE

If the projector's lens becomes damaged or broken it should be replaced. If the lamp becomes damaged or deformed in any way it must be replaced. If the light from the lamp appears dim this would normally indicate that it is reaching the end of its life and it should be changed at once, aged lamps run to the extremity of their life might explode. If the projector does not function, check the fuses on the power socket of the projector, they should only be replaced by fuses of the same specification. Should these be damaged call a qualified technician before replacement. The projector has thermal protection device that will switch off the projector in case of overheating, should either of these operate, check that the fans are not blocked, and if they are dirty clean them before switching on the projector again. Check that the fans are operational, if not call a qualified technician.

**Any maintenance work should only be carried out by qualified technicians.**

## LUBRICATION

To ensure the smooth motion of the inside Zoom lens, it is recommended that the shafts for the Zoom lens holder be lubricated periodically, preferably every two months. Use only high quality, high-temperature resistant grease instead of any type of oil.

## KEEPING THE PROJECTOR CLEAN

To ensure the reliability of the projector it should be kept clean. It is recommended that the fans should be cleaned every 15 days. The lens and dichroic colour filters should also be regularly cleaned to maintain an optimum light output. **Do NOT use any type of solvent on dichroic colour filters.**

Cleaning frequency depends on the environment in which the fixture operates: damp, smoke or particularly dirty surroundings can cause greater accumulation of dirt on the unit's optics. A soft cloth and typical glass cleaning products should be used in cleaning. It is recommended to clean the external optics at least once every 20 days and clean the internal optics at least once every 30 / 60 days.

**Do not use any organic solvent, e.g. alcohol, to clean the reflector mirror, dichroic colour filters or housing of the apparatus.**

## TROUBLESHOOTING

PROBLEM	ACTION
The projector doesn't switch on	<ul style="list-style-type: none"> <li>➤ Check the fuse on the power socket.</li> <li>➤ Replace the lamp.</li> </ul>
The lamp comes on but the projector doesn't respond to the controller	<ul style="list-style-type: none"> <li>➤ Make sure that the projector is correctly configured.</li> <li>➤ Replace or repair the DMX cable.</li> </ul>
The projector only functions intermittently	<ul style="list-style-type: none"> <li>➤ Make sure the fan is working and not dirty.</li> </ul>
Defective projection	<ul style="list-style-type: none"> <li>➤ Check the lenses are not broken.</li> <li>➤ Remove dust or grease from the lenses.</li> </ul>
The project image appears to have a halo	<ul style="list-style-type: none"> <li>➤ Make sure the lamp is installed correctly.</li> <li>➤ Carefully clean the optical group lenses and the projector components.</li> </ul>
The beam appears dim	<ul style="list-style-type: none"> <li>➤ Check the optics is clean.</li> <li>➤ Replace with a new lamp of the specified type and rating.</li> </ul>

## TECHNICAL DATA

### **VOLTAGES:**

Electronical ballast(PR-2805): 200/220/230/240V AC, 50/60Hz  
Options: 100/120V AC, 50/60Hz

Magenetic ballast(PR-2805M): 220VAC , 50/60Hz  
Options: 200/230/240V AC, 50/60Hz

### **POWER CONSUMPTION:**

Electronical ballast(PR-2805): 1700W@220V  
Magenetic ballast(PR-2805M): 1800W@220V

### **LAMP:**

OSRAM HTI 1500 W/D7/60  
Colour Temperature 6000°K  
Socket SFc10-4, double ended  
Manufacturers Rated Lamp Life 750 Hours replacement  
Or  
PHILIPS MSR Gold 1510 SA DE  
Colour Temperature 5800°K  
Socket SFc10-4, double ended  
Manufacturers Rated Lamp Life 750 Hours replacement

### **COLOURS:**

Smooth CYM colour mixing system with macros  
2 wheels each with 6 dichroic colour filters plus white and CYM colour mixing system  
With variable speed bi-directional rainbow effect  
Step/linear colour changing is available

### **COLOUR TEMPERATURE CORRECTION:**

Linearly colour temperature correction

### **FOCUS:**

DMX controlled focus

### **DIMMER:**

0-100% linearly adjustable

### **SHUTTER:**

Double shutter blades, 0.3~12 F.P.S  
Macros



**HEAD MOVEMENT:**

Pan 450°, Tilt 270° with auto position correction

**BEAM ANGLE:**

10° narrow angle mode

15° ~42°

**CONTROL:**

DMX512, 3 pin, 5 pin interfaces

14 channels in short mode, 17 channels in standard mode, and 23 channels in extended mode.

Self-test mode

**OTHER FUNCTIONS:**

Adjustable Pan & Tilt speed

Fixture and lamp usage time display

LCD display with English and Chinese language menu

Energy saving function of the ballast

Built-in analyzer for easy fault finding, error messages

Built-in demo sequences

Setup options by chargeable battery inside without power connection.

Input signal isolating protection

Network interface (Reserved)

**HOUSING:**

Composite plastic, IP20

**WEIGHT:**

Electronical ballast(PR-2805): 32kg

Magenetic ballast(PR-2805M): 45kg

**SIZES:**

See at below

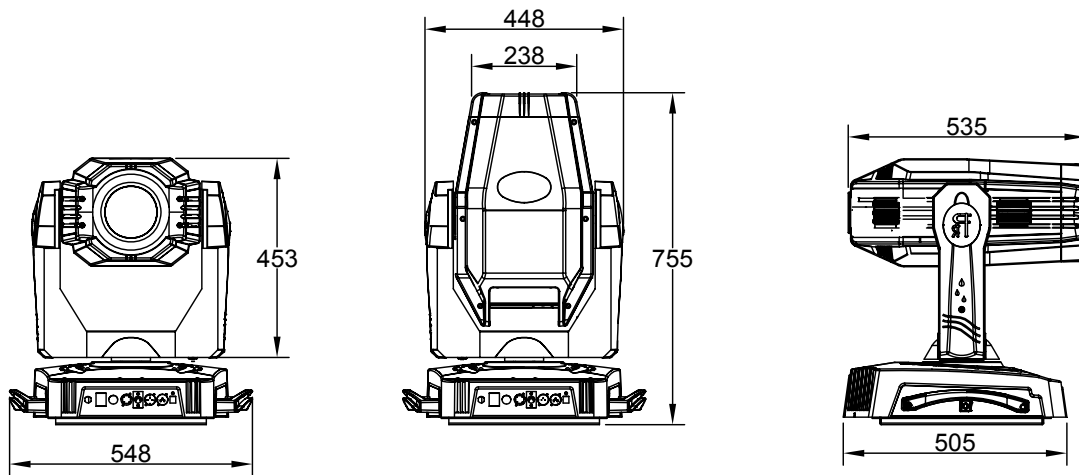

**LIGHT OUTPUT:**

42° ( lux )	6830	1700	760	430	270
15° ( lux )	38120	9730	4230	2380	1520
10° ( lux )	85770	21440	9530	5360	3430

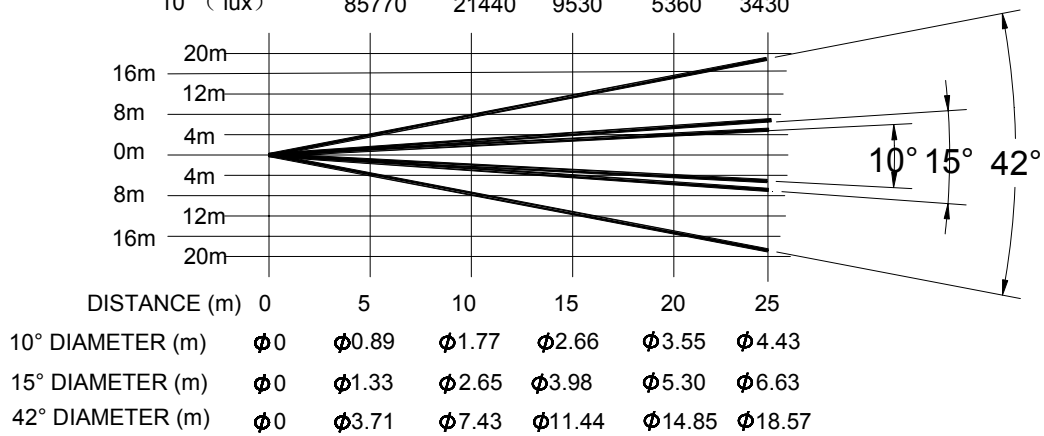

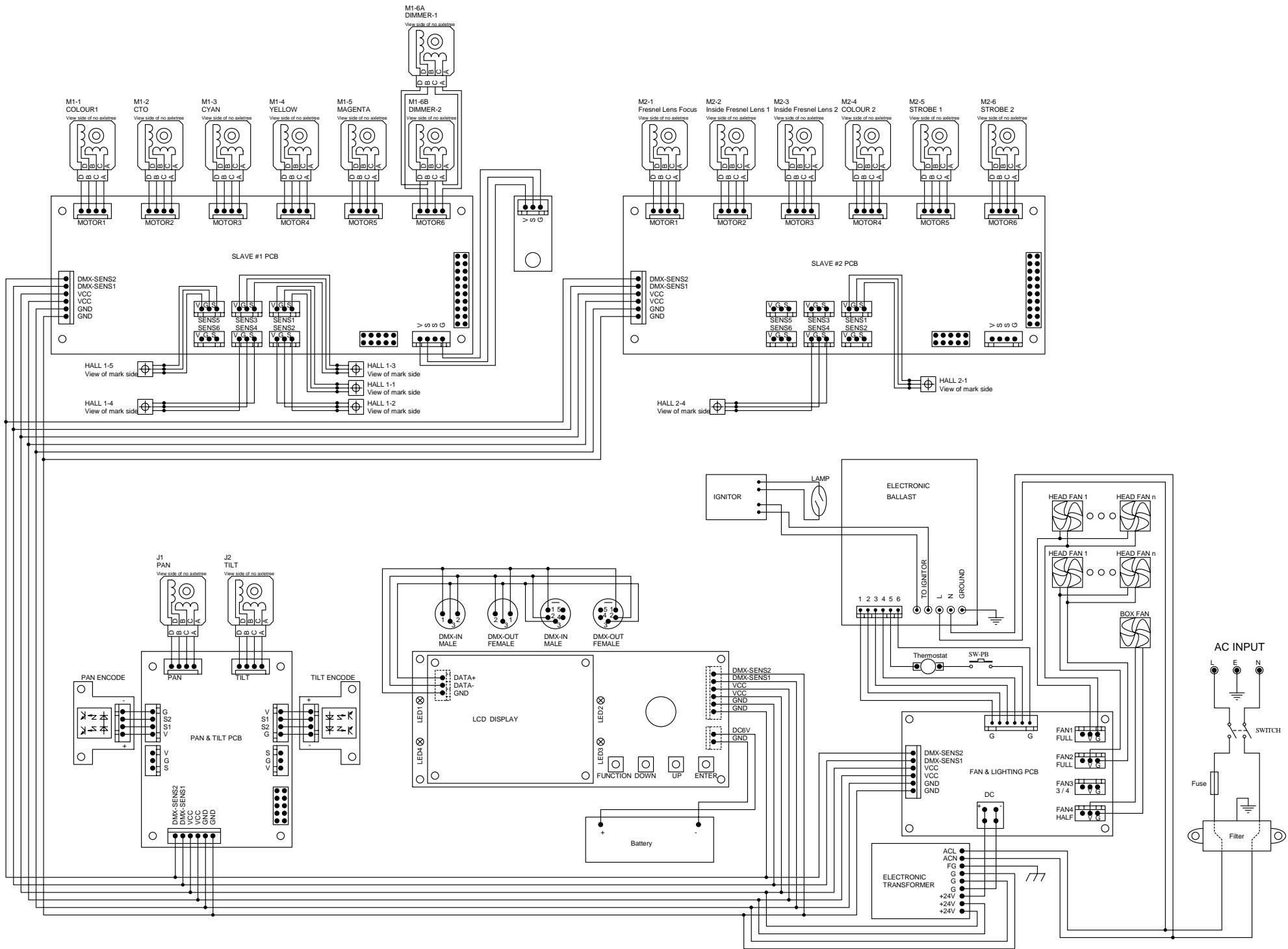

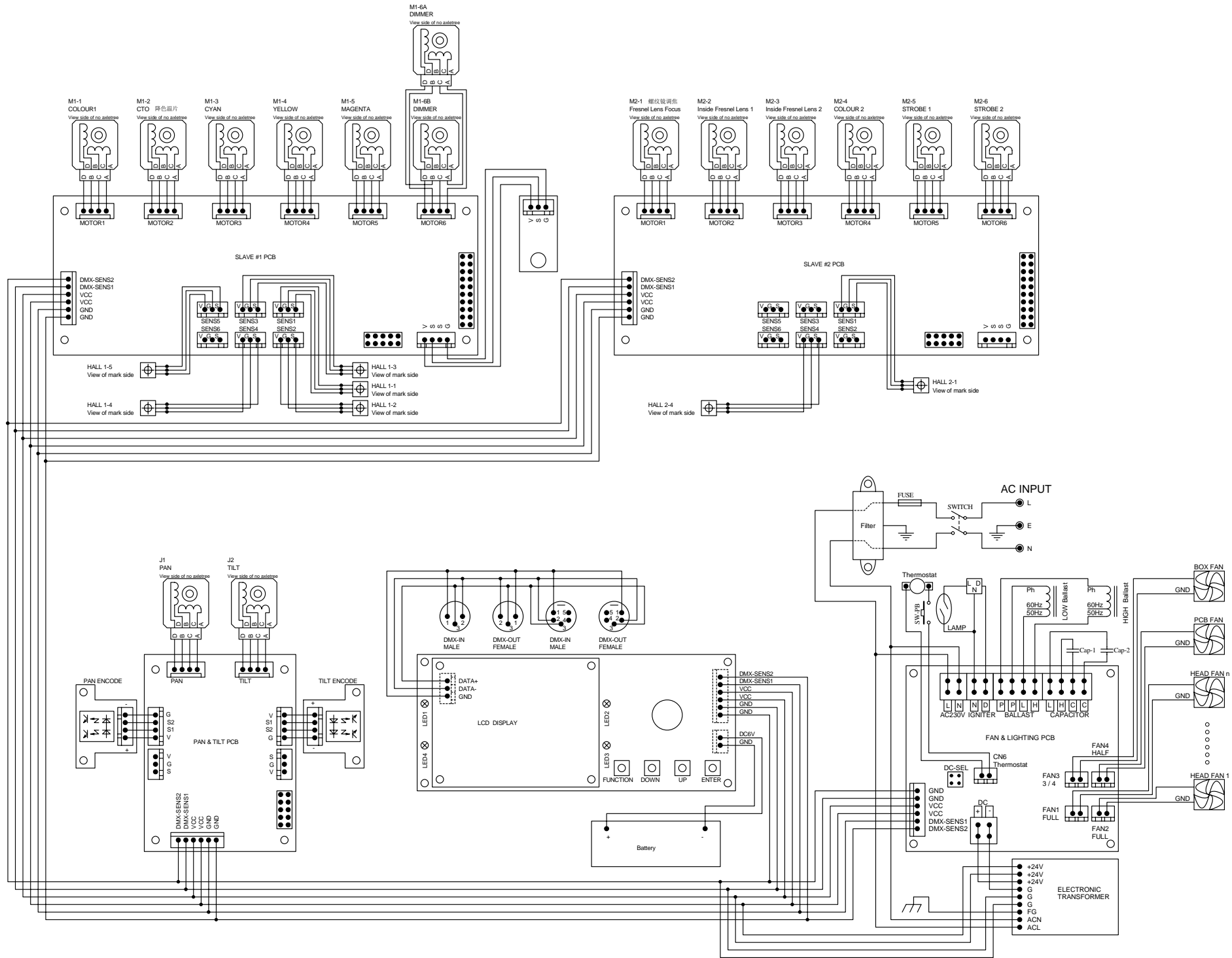

## COMPONENT ORDER CODES

NAME	PART NO.	QUANTITY	REMARK
POWER SUPPLY	190010098	1	24V
MAINS FILTER	193020008	1	20A 115/250VAC
THERMOSTAT	190010074	1	150°C
CAPACITOR****	140010060	2	80µF/370V
BALLAST****	040070000	2	230V/50-60Hz
IGNITOR****	040090048	1	4~5KV/1800W
LAMP	100050072	1	HTI 1500W/D7/60
TILT DRIVE BELT	290151241	1	HTD-750-3M
PAN DRIVE BELT	290151234	1	HTD501-3M
FAN IN BASE	030060056	1	BP802524L-03 24V/0.12A
FAN IN FRONT SIDE	030060053	2	BP802524H-03 24V/0.21A
FAN IN BACK SIDE	030060055	2	3106KL-05W-B50 24V/0.16A
FAN NEAR THE LAMP(SMALL )	030060058	1	24V 0.3A
FAN NEAR THE LAMP(LARGE )	030060059	1	24V 0.35A
FAN NEAR THE CYM	030060052	3	BP501024H 24V/0.09A
FAN NEAR THE POWER PCB	030060057	1	SP602524H-03 DC24V/2.88W
PAN MOTOR	030040089	1	23HS2039L 6.35*25
TILT MOTOR		1	
DIMMER MOTOR	030040093	2	17HD0013-33L 5*35
ZOOM MOTOR	030040060	1	39BYG501-4A 5*24
CYM-CYAN MOTOR	030040114	1	16HY7001-30L 5*40
CYM-YELLOW		1	
CYM-MAGENTA MOTOR		1	
CTO MOTOR		1	
COLOUR WHEEL 1 MOTOR		030040096	
COLOUR WHEEL 2 MOTOR	030040084	1	17HS0002-59L 5*28
ZOOM LENS MOTOR	030040081	2	14HY5003-01L 5*12
SHUTTER BLADE MOTOR	030040116	2	16HY7001-32L 5*15
PAN/TILT DRIVE PCB	230020177	1	
MOTOR DRIVE PCB 1	230020178	1	
MOTOR DRIVE PCB 2	230020189	1	
POWER PCB	230020223A	1	
DISPLAY PCB	230020220A	1	
POWER PCB****	230020227A	1	

\*\*\*\*Only apply to Magnetic ballast

PR LIGHTING LTD.

---

1582 Xingye Avenue, Nancun Panyu  
Guangzhou, 511442 China  
TEL: +86-20-3995 2888  
FAX: +86-20-3995 2330

---

P/N: 320020013  
Last Revision:20080924