

LMC-1 User's Manual

Table of Contents

Introduction	3
IO Ports	3
Description of signals	3
Scanhead Control Signals	3
LASER.....	4
PWM, ANAPORT1, ANAPORT2	4
FPK [first pulse killer]	4
Extended Axis's Control Signals	6
General Digit Input output signals and START signal.....	7
EX5V and EXGND.....	7
DB37 : Pin Assignments	8
Electrical Description	9
General Digital Input.....	9
General Digital Output	10
Change the maximum voltage of ANAPORT1 and ANAPORT2	10
Typical Connection	11

Introduction

LMC-1 Marking Control Board is especially developed for scanhead and laser control in real time with a PCI bus interface. It is used with YmMarker software to control laser marking.

IO Ports

- six analog output ports (four of them are used for scanhead.);
- 2 axes control for step/servo motor
- LASER signal [TTL]
- FPK (First Pulse Kill) signal [TTL]
- PWM signal [TTL]
- START signal [OPTOISOLATED]
- 4 bit General Digit Input signals [OPTOISOLATED]
- 2 bit of General Digit Output signals (A External +5V Power Supply is required)

Description of signals

Scanhead Control Signals

Two analog output are used for scanhead. The inverse output is also available. Under the case of the single ended mode, the default range of output voltage is [-5V , +5V] . Users can customize the output voltage range according the scanhead used when ordering the product. The maximum of output voltage range is [-10V , +10V] for single ended mode, [-20V , +20V] for differential mode.

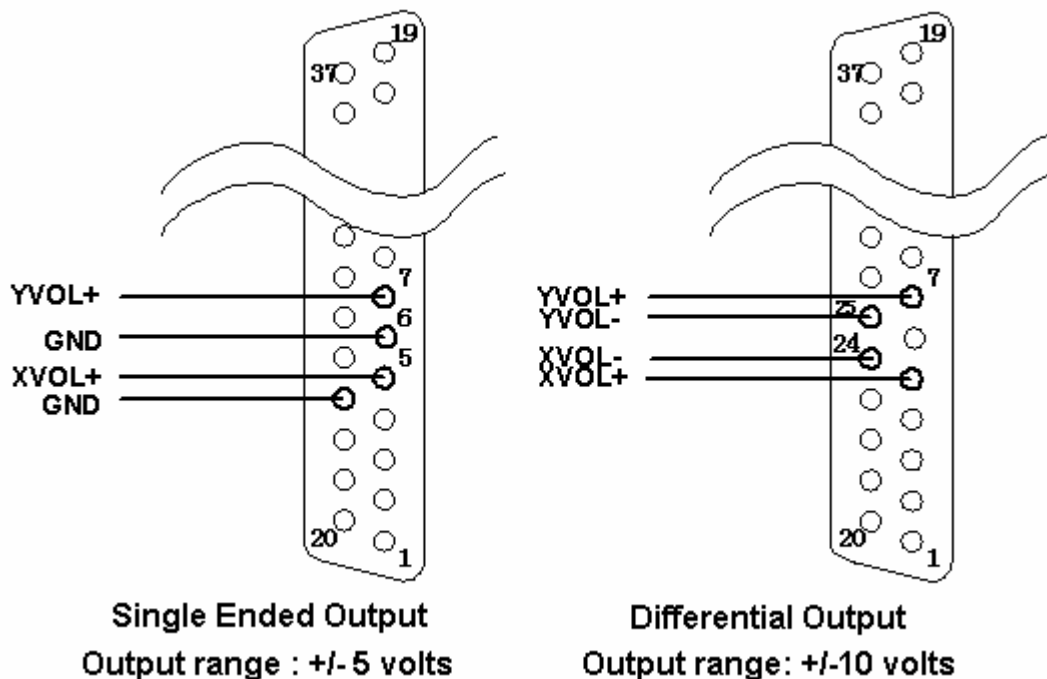

Figure 1 Analog signals to scanhead [Default output range: +/-5 volts]

Caution: The output voltage range under differential mode is double times of that under single ended mode.

Caution: Please confirm that the galvo driver support differential input before using differential mode. Otherwise the control board may be damaged.

LASER

TTL signal. High level is effective for lasing.

PWM, ANAPORT1, ANAPORT2

LMC-1 control board offers one PWM signal and two analog signals to adjust the laser power. Users can adopt either the PWM signal or the analog signals according to the equipment's configuration.

The analog signal ANAPORT2 is used to adjust the modulated frequency of the Acousto-Optic Q-switch power supply. The voltage range is 0V to 5V (DB37 - Pin2). The "Frequency" parameter in YmMarker software configures the output voltage of this signal.

Another analog signal ANAPORT1 is used to adjust the output currents of the lamp-pumped power supply. The voltage range is from 0V to 9.5V (DB37 - Pin20), The "Power" parameter in YmMarker software configure the output voltage of this signal.

The frequency and pulse width of the PWM signal are specified in YmMarker software. The PWM signal can be used as either the PWM signal of the RF Excited CO2 Laser tube or the outside modulation signal of the Acousto-Optic Q-switch Power Supply.

FPK [first pulse killer]

The first pulse of a pulse train often has a higher energy than the following pulses. The intensity variation should be avoided in most laser marking applications. Therefore the first pulse should be suppressed. The **FPK** signal is started together with the **LaserOn** signal. While the **FPK** signal is active, the energy of the pulse should be reduced adequately. There are two modes that the signal works. See the following figures.

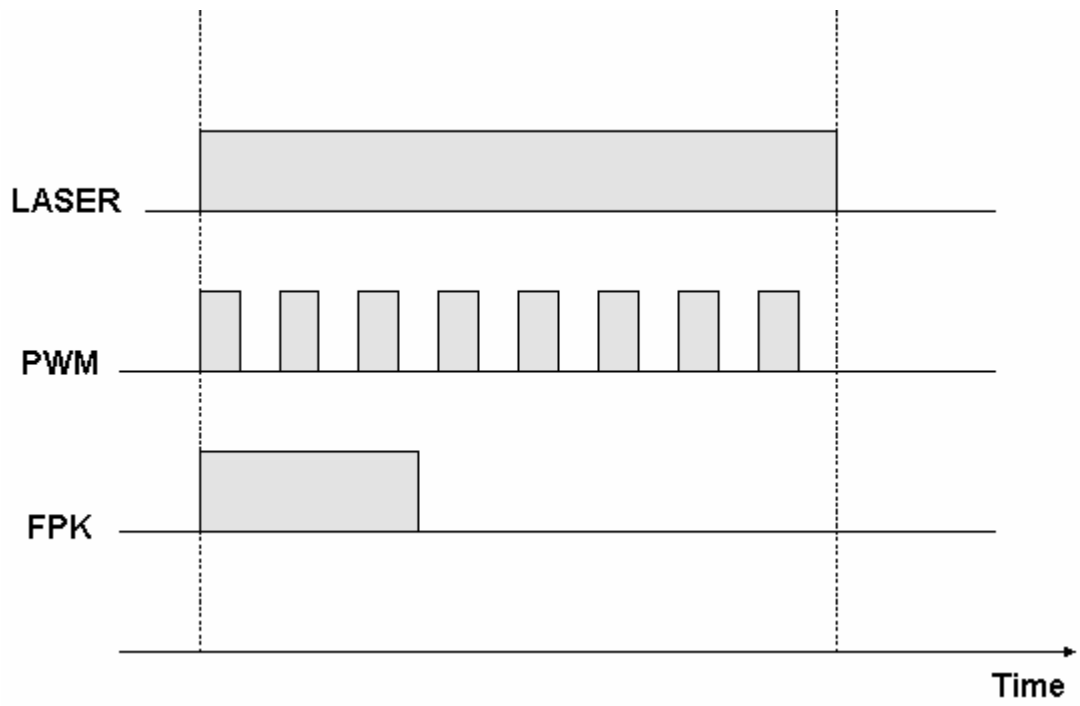

Figure 2 : FPK Mode 1

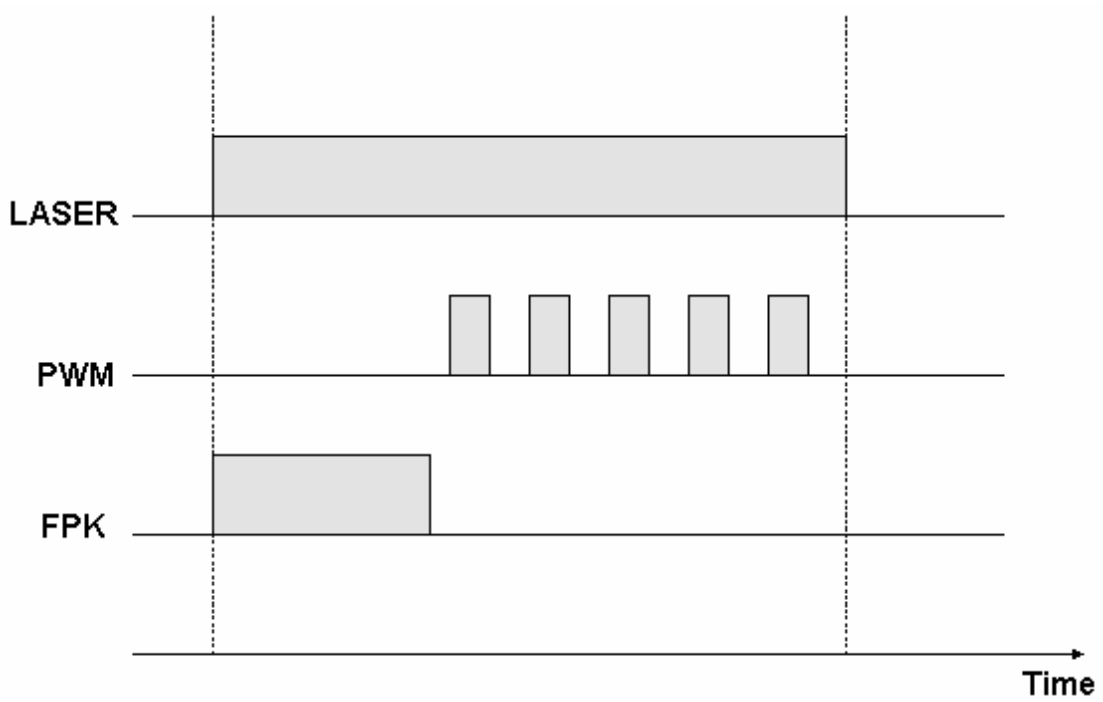

Figure 3 : FPK Mode 2

Extended Axis's Control Signals

The control card exports dual direction/pulse signals for step/servo motor drivers. Direction/pulse signals export in two ways: Differential Mode and Single ended Mode. The jumpers JP1~JP4 used to select the mode. The table below shows concrete ways of control.

Mode	Pins to shorted
Differential	1-2
Single Ended	2-3

JUMPER	Signal	Description
JP1	ADIR+	Direction for axis A
JP2	APUL+	Pulse for axis A
JP3	BDIR+	Direction for axis B
JP4	BPUL+	Pulse for axis B

Under the Differential Mode, use the signals APUL+ (Pin-30), APUL- (Pin-11), ADIR+ (Pin-31), ADIR- (Pin-12) for axis A and the signals BPUL+ (Pin-28), BPUL- (Pin-9), BDIR+ (Pin-29), BDIR- (Pin-10) for axis B, Under the Single Ended Mode, use the signals +5V (Pin-26), APUL+ (Pin-30), ADIR+ (Pin-31) for axis A and the signals +5V (Pin-26), BPUL+ (Pin-28), BDIR+ (Pin-29) for axis B. Figure 4 and 5 show the connection for the Differential Mode and the Single Ended Mode respectively.

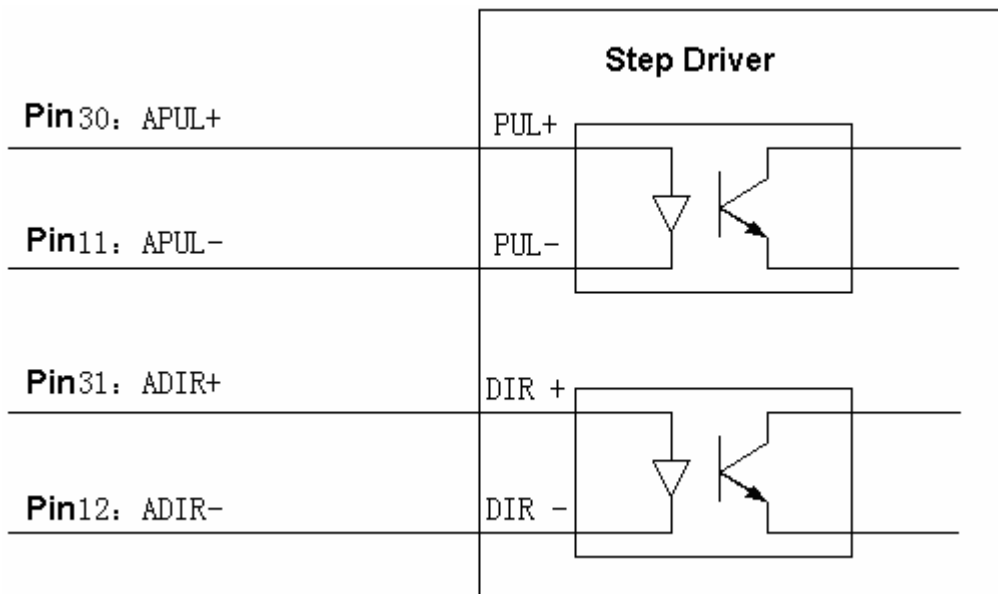

Figure 4: Differential Mode connection for axis A

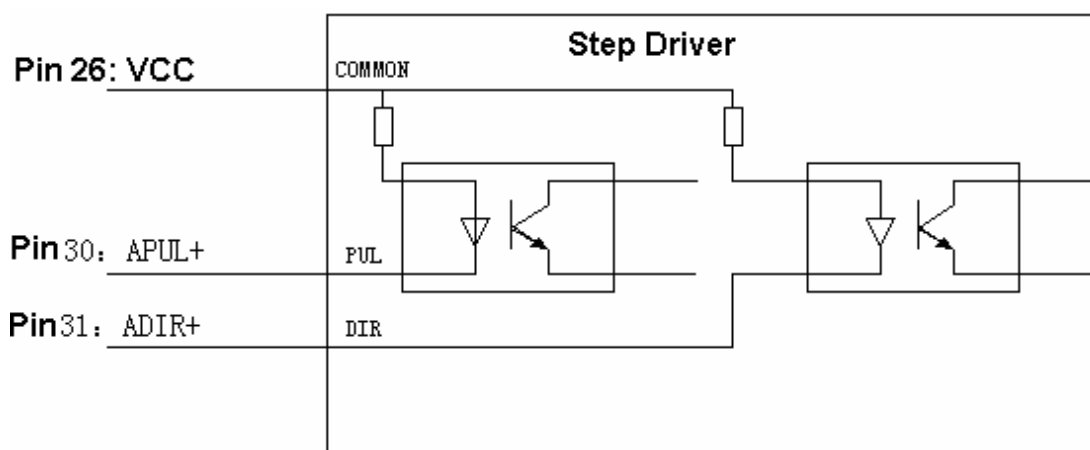

Figure 5: Single Ended Mode connection for axis A

General Digit Input | output signals and START signal

The control board offers five input signals. One of them is the “Start” signal, which can be provided by the Footplate or other exterior modules; the other four are general input signals that can be connect to auxiliary devices.

The control board offers two output signals. We can custom the output signals in YmMarker software.

EX5V and EXGND

An auxiliary +5V/1A power supply is needed when using the output signals. If the output signals are not used, this power supply can be removed.

DB37 : Pin Assignments

No.	Name	Description	References	Characteristics
1	GND	Ground. Return path for Pin 2, 3, 4, 5, 7, 8, 20, 22, 24, 25, 26. It is the ground of mainboard of the computer.		
2	ANAPORT2	Analog (Frequency) Output Port [0V-5V]	GND	Analog
3	FPK	First Pulse Killer	GND	TTL
4	LASER	Laser On/Off	GND	TTL
5	XVOL+	Galvo X [$\pm 5V$]	GND	Analog
6	GND	See Pin1.		
7	YVOL+	Galvo Y [$\pm 5V$]	GND	Analog
8	VCC	+5V Output. It's from the computer power supply.	GND	TTL
9	BPUL-	Negative Pulse Signal of Axis-B		TTL
10	BDIR-	Negative Direction Signal of Axis-B		TTL
11	APUL-	Negative Pulse Signal of Axis-A		TTL
12	ADIR-	Negative Direction Signal of Axis-A		TTL
13	OUT1	General digital output	EXGND	TTL
14	EXGND	Ground of auxiliary power supply. For Pin 13, 32, 33.		
15	IN3	General digital Input	S23GND	
16	IN2	General digital Input	S23GND	
17	S01GND	Common return path of Input IN0 & IN1		
18	RESERVE	NULL		
19	START	Input signal which will trigger marking.	SSGND	TTL
20	ANAPORT1	Analog (Power) Output Port [0V-9.5V]	GND	Analog
21	GND	See Pin1.		
22	PWM	Pulse-Width Modulation. Both frequency and duty can be adjusted. A general digital modulation signal.	GND	TTL
23	GND	See Pin1.		
24	XVOL-	Reverse output of XVOL+. Used with XVOL+ for differential connection.	GND	Analog
25	YVOL-	Reverse output of YVOL+. Used with YVOL+ for differential connection.	GND	Analog
26	VCC	+5V Output. It's from the computer power supply.		
27	GND	See Pin1.		
28	BPUL+	Positive Pulse Signal of Axis-B		TTL
29	BDIR+	Positive Direction Signal of Axis-B		TTL
30	APUL+	Positive Pulse Signal of Axis-A		TTL
31	ADIR+	Positive Direction Signal of Axis-A		TTL
32	OUT0	General digital output	EXGND	TTL
33	EX5V	5V Input. The positive pole of auxiliary power supply.	EXGND	
34	S23GND	Common Ground of IN2 & IN3		
35	IN1	General digital Input	S01GND	
36	IN0	General digital Input	S01GND	
37	SSGND	Return path for START signal.		

Electrical Description

The following will show the equivalent circuit of general input/output signals.

General Digital Input

All general digital input are optoisolated. The recommended forward current of diode is 10mA ~ 15mA. A 330-ohm resistor is used to restrict the forward current. If the input voltage is higher than 5 volt then a external current limited resistor is needed.

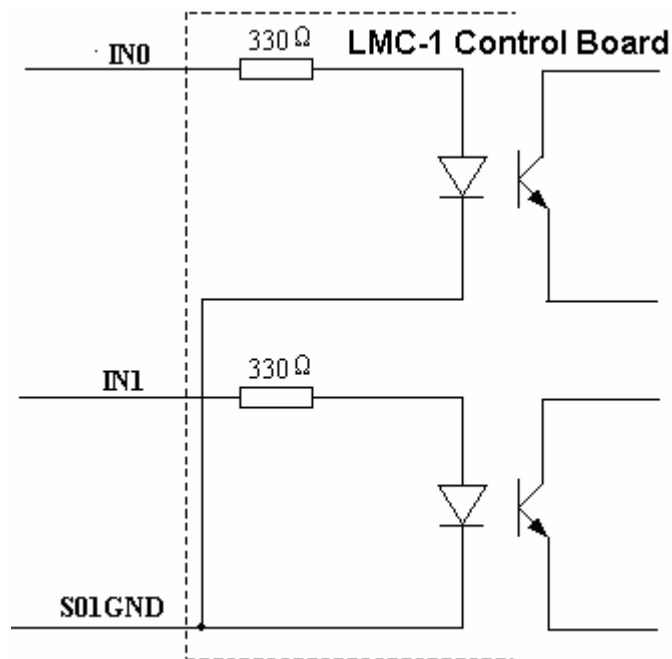

Figure 6: Equivalent circuit for general input IN0 & IN1

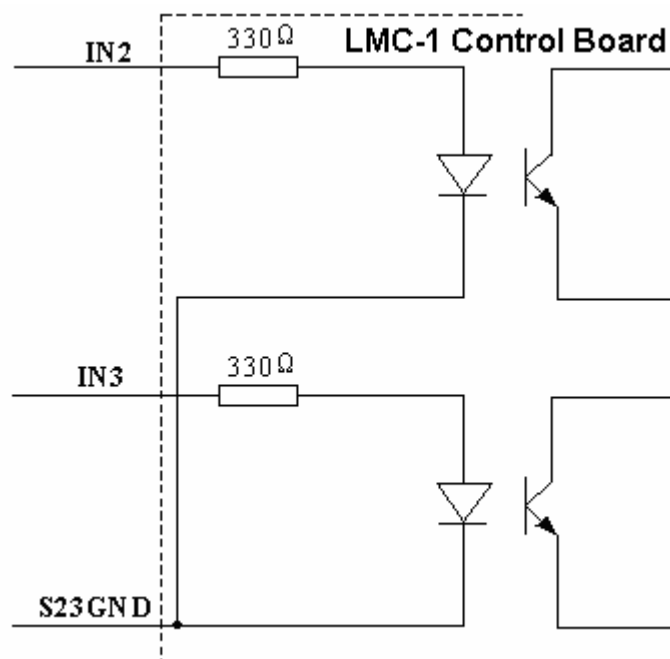

Figure 7: Equivalent circuit for general input IN2 & IN3

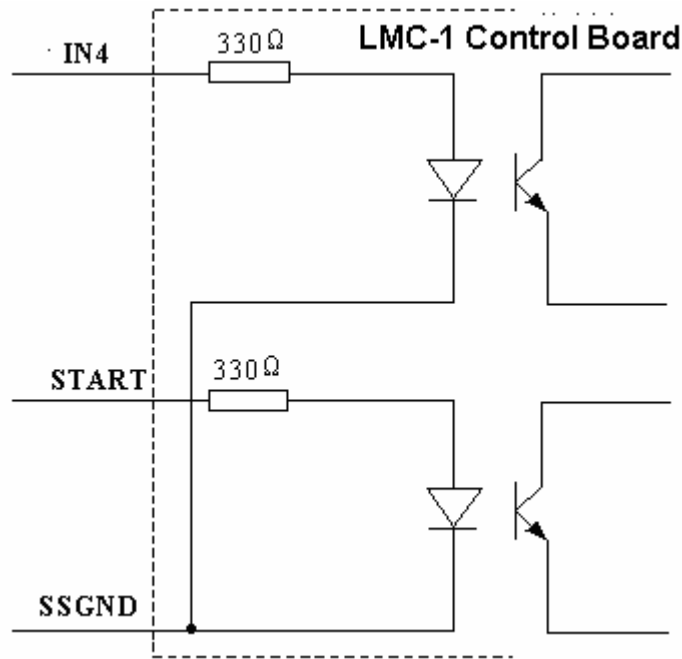

Figure 8: Equivalent circuit for START

General Digital Output

An auxiliary power supply of 5V/1A must be present to use the general digit output. The output signal is TTL output. The maximum output current is 10mA.

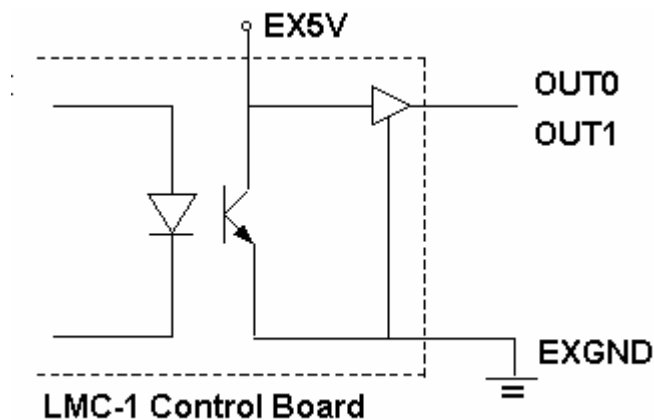

Figure 9: Equivalent circuit for output signal

Change the maximum voltage of ANAPORT1 and ANAPORT2

ANAPORT1 : The default maximum volt is +9.5V, and it can be changed through replacing R254 and R255 together. (Resistance Value range from 8K-20K, the corresponding voltage is 4V-10V.)

ANAPORT2 : The default maximum volt is +5V, and it can be changed through replacing R261 and R262 together. (Resistance Value range from 8K-20K, the corresponding voltage of electricity is 4V-10V.)

Typical Connection

In the case that the Acousto-Optic Q-switch driver need only LASER signal

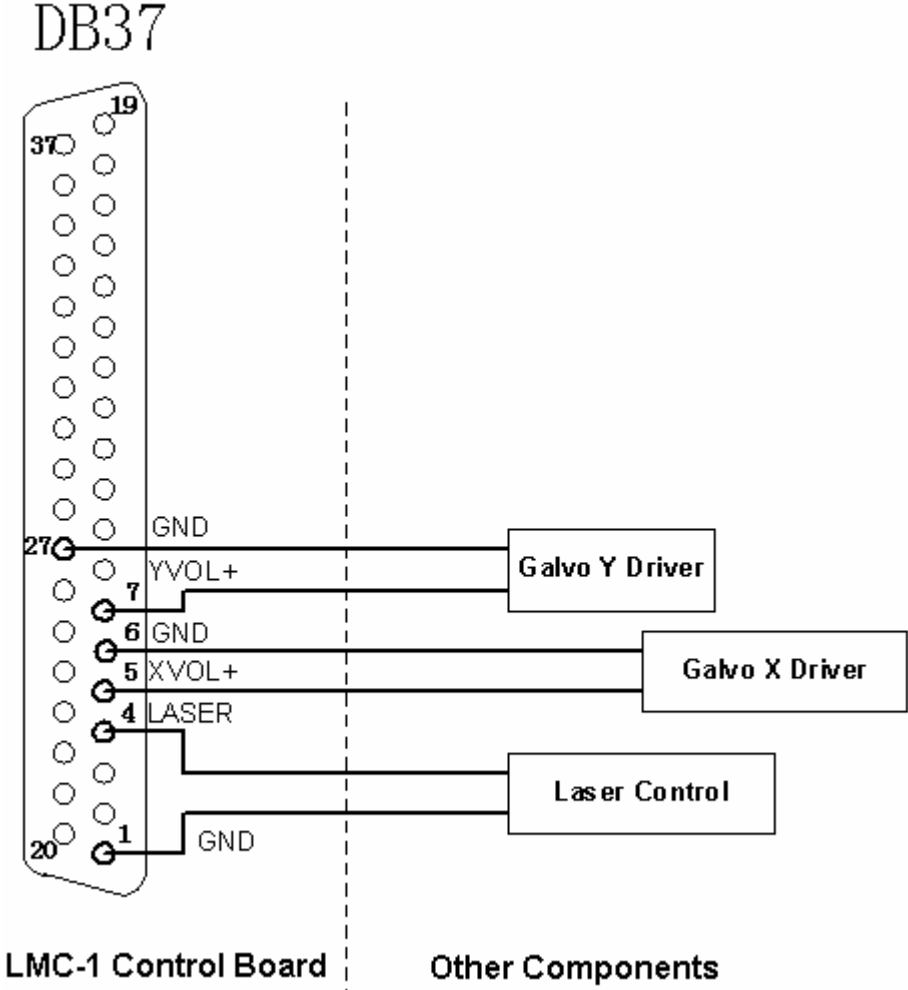

Figure 10: Connection 1

DB37

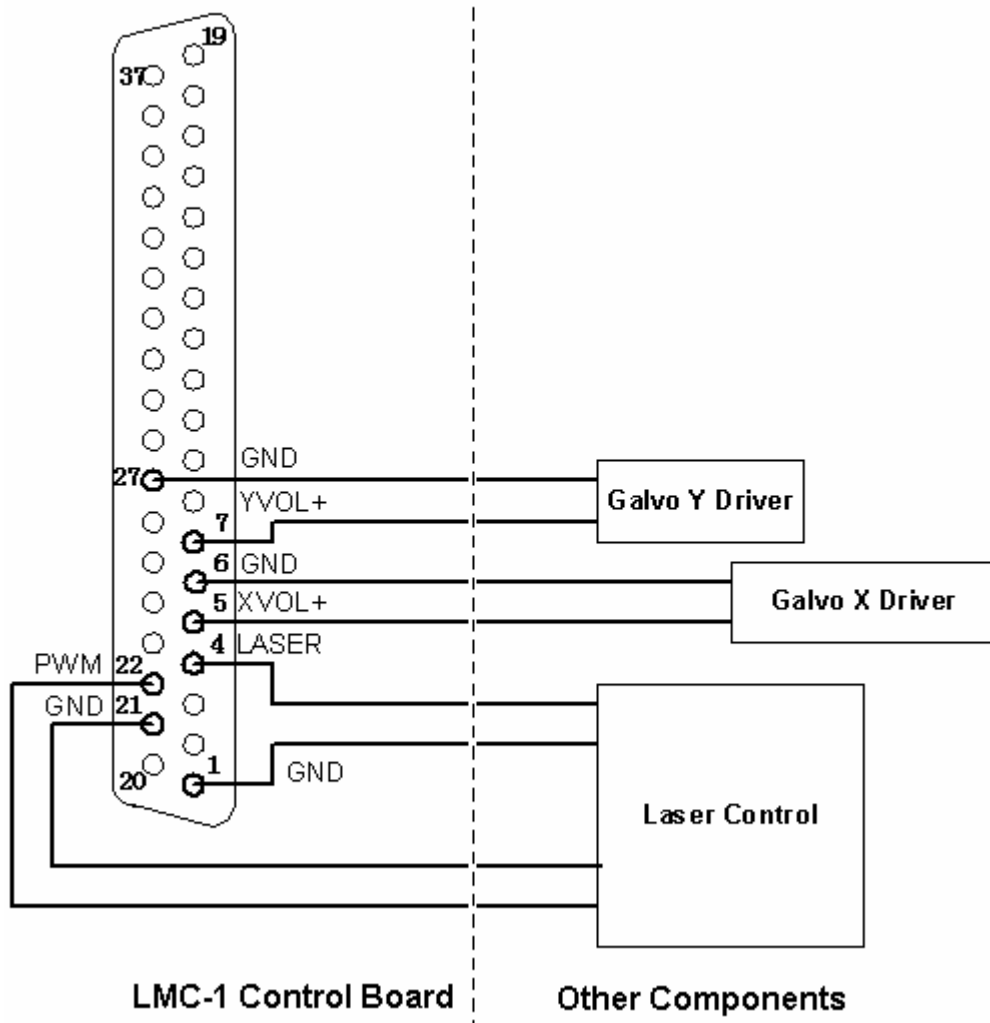

Figure 11: Connection 2