

TP1030-LB□-□□V
TP1030 General Description

Manual Number	TP1030GS-2012-4
Date	April, 2012

This manual describes the specification of the product. Before use, read this manual and manuals of relevant products fully to acquire proficiency in handling and operating the product.

Make sure to learn all the product information, safety information and precautions.

And store this manual in a safe place so that you can take it out and read it when necessary. Always forward it to the end users.

Registration

The company name and product name described in this manual are the registered trademarks and trademarks of each company.

Effective April, 2014

Specification are subject to change without notice.



©2008 HCFA Corporation

Safety precaution (Read before use)

Before using this product, please read this manual and the relevant manuals introduced in this manual and pay full attention to safety to handle the product correctly.

The precautions given in this manual are concerned with this product.

In this manual, the safety precautions are ranked as “**DANGER**” and “**CAUTION**”.

 DANGER	Indicates that incorrect handling may cause hazardous conditions, resulting in death or severe injury.
 CAUTION	Indicates that incorrect handling may cause hazardous conditions, resulting in medium or slight personal injury or physical damage.

Depending on circumstances, procedures indicated by “CAUTION” may also linked to serious results.

In any case, it is important to follow the directions for the usage.

Design Precautions	 DANGER
<p>•Some failure of the HMI or cable may keep the outputs ON or OFF.</p> <p>An external monitoring circuit should be provided to check for output signals which may lead to a serious accident.</p> <p>Not doing so can cause an accident due to false output or malfunction.</p> <p>•If a communication fault (including cable disconnection) occurs during monitoring on the HMI, communication between the HMI and PLC CPU is suspended and the HMI becomes inoperative.</p> <p>A system where the HMI is used should be configured to perform any significant operation to the system by using the switches of a device other than the HMI on the assumption that HMI communication fault will occur.</p> <p>Not doing so can cause an accident due to fault output or malfunction.</p> <p>•Do not use the HMI as the warning device that may cause a serious accident.</p> <p>An independent and redundant hardware or mechanical interlock is required to configure the device that displays and outputs serious warning.</p> <p>Failure to observe this instruction may result in an accident due to incorrect output or malfunction.</p> <p>•Incorrect operation of touch switches may lead to a serious accident if the HMI backlight goes out.</p>	

When the HMI backlight goes out, causes the monitor screen to appear blank, while the input of touch switches remain active. This may confuse an operator in thinking that the HMI is in "screensaver" mode, who then tries to release the HMI from this mode by touching the display section, which may cause a touch switch to operate.

Design Precautions



- Do not bundle the control or communication cables with main-circuit, power or other wiring. Run the above cables separately from such wiring and keep them a minimum of 100mm(3.94in.) apart. Not doing so noise can cause a malfunction.
- Do not use the tip of the pen, screwdrivers and similar objects to operate the panel. Doing so may break the screen.

Mounting Precautions



- Be sure to shut off all phases of external power supply used by the system before mounting or removing the HMI to/ from the panel. Not doing so can cause the unit to fail or malfunction.
- When installing the battery wear an earth band etc. to avoid the static electricity. The static electricity can cause the unit to fail or malfunction.

Mounting Precautions



- Use the HMI in the environment that satisfies the general specification described in the manual. Not doing so can cause an electric shock, fire, malfunction or product damage or deterioration.
- When mounting the HMI to the control panel, tighten the mounting screws in the specified torque range. Under-tightening can cause the HMI to drop, short circuit and malfunction. Over-tightening can cause a drop, short circuit or malfunction due to the damage of the screws or the HMI.

Wiring Precautions



- Be sure to shut off all phases of external power supply used by the system before wiring. Failure to do so may result in an electric shock, product damage or malfunctions.
- Please make sure to ground FG terminal of the HMI power supply section by applying 100 or less which is used exclusively for the HMI. Not doing so may cause an electric shock or malfunction.
- Correctly wire the HMI power supply section after confirming the rated voltage and terminal arrangement of the product. Not doing so can cause a fire or failure.
- Tighten the terminal screws of the HMI in the specified torque range. Under-tightening can cause a short circuit or malfunction. Over-tightening can cause a short circuit or malfunction due to the damage of the screws or the HMI.
- Exercise care to avoid foreign matter such as chips and wire offcuts entering the HMI. Not doing so can cause a fire, failure or malfunction.

Wiring Precautions



- Plug the communication cable into the connector of the connected unit and tighten the mounting and terminal screws in the specified torque range. Under-tightening can cause a short circuit or malfunction. Over-tightening can cause a short circuit or malfunction due to the damage of the screws or unit

Test Operation Precautions



DANGER

- Before performing the test operation of the user creation monitor screen (such as turning ON or OFF bit device, changing the word device current value, changing the setting or current values of timer or counter), read through the manual carefully and make yourself familiar with the operation method.

During test operation, never change the data of the device which are used to perform significant operation for the system.

False output or malfunction can cause an accident.

Startup/ Maintenance Precautions



DANGER

- When the power is ON, do not touch the terminals.
Doing so can cause an electric shock or malfunction.

- Connect the battery correctly.

Do not discharge, disassemble, heat, short, solder or throw the battery into the fire.

Incorrect handling may cause the battery to generate heat, burst or take fire, resulting in injuries or fires

- Before starting cleaning or terminal screws retightening, always switch off the power externally in all phases. Not switching the power off in all phases can cause a unit failure or malfunction. Under-tightening can cause a short circuit or malfunction.

Over-tightening can cause a short circuit or malfunction due to the damage of the screws or unit.

Startup/ Maintenance Precautions



CAUTION

- Do not disassemble or modify the unit.

Doing so can cause a failure, malfunction, injury or fire.

- Do not touch the conductive or electric parts of the units directly.'

Doing so can cause a unit malfunction or failure.

- The cables connected to the unit must be run in ducts or clamped.

Not doing so can cause the unit or the cable to be damaged due to the dangling, motion or accidental pulling of the cables or can cause a malfunction due to a cable connection fault.

- When unplugging the cable connected to the unit, do not hold and pull the cable portion. Doing so can cause the unit or cable to be damaged or can cause a malfunction due to a cable connection fault.

- Do not drop or apply any impact to the battery.

If any impact has been applied, discard the battery and never use it.

The battery may be damaged by the drop or impact.

- Before touching the unit, always touch grounded metal, etc. to discharge static electricity from human body, etc.

Not doing so can cause the unit to fail malfunction.

- The battery TP11-50BAT manufactured by HCFA should be used.

Not doing so can cause a fire or malfunction.

Disposal Precautions



CAUTION

- When disposing of the product, handle it as industrial waste.

Transportation Precautions



CAUTION

- Before transporting the HMI, turn the HMI power on and check that the battery voltage status is normal on the Timing setting& display screen (utilities screen). In addition, conform that In addition, confirm that the adequate battery life remains on the rating plate.

Transporting the HMI with the low battery voltage or the battery the reached battery life may unstabilize the backup data unstable during transportation

- Make sure to transport the HMI main unit and/ or relevant unit(s) in the manner they will not be exposed to the impact exceeding the impact resistance described in the general specification of this manual, as they are precision devices. Failure to do so may cause the unit to fail.

Check if the unit operates correctly after transportation.

⚠ NOTES

- This product belongs to industrial products.
- Manufacturer: Zhejiang HeChuan Technology Co., Ltd
- Head address: No. 9, Fucai Road, Longyou Chengbei Industrial Zone, Quzhou, Zhejiang Province, PRC

Requirement for Compliance with EMC directive

The following products have shown compliance through direct testing(to the identified standards) and design analysis (forming a technical construction file) to the European Directive for Electromagnetic Compatibility (2004/ 108/EC) when used as directed by the appropriate documentation.

Type :Programmable Controller (Open Type Equipment)

Standards		Remark
EN61131-2 : 2007 Programmable controllers- Equipment, requirement and tests	EMI	Compliance with all relevant aspects of the standard. (Radiated Emissions)
	EMS	Compliance with all relevant aspects of the standard. (ESD,RF electromagnetic field, EFTB, Surge, RF conducted disturbances and Power frequency magnetic field

For more details please contact the HCFA sales site.

Notes for compliance to EMC regulation

1) General notes on the use of communication cables

Any device which utilizes a data communication function is susceptible to the wider effects of local EMC noise. Therefore, when installing any communication cables care should always be taken with the routing and location of those cables. The HMI units identified on the previous chapter are compliant with the EMC requirement when the following communication cables are used

HMI Unit	Existing Cables
TP1030-LBD-24V, TP1030-LBL-5V	TP10-PLC-R4-8P (For TX/ LX series PLC)
TP1030-LBD-24V, TP1030-LBL-5V	TP10-PC-R2-6P (For computer connection)

2) General notes on the use of the power cable

The HMI unit demand that the cable for the power supply is 10m or less.

Associated Manuals

The following manuals are relevant to this product. When these loose manuals are required, please consult with our local distributor.

Manual name	Contents	Manual Number (Model Code)
TP10 User's Manual (sold separately)	Describes the TP10 hardware-relevant content, such as part names, external dimensions, mounting, power supply wiring, specification and introduction to option devices.	TP10ZJSM
TP10 Series Connection Manual 1/3, 2/3, 3/3 (sold separately) *1	Describes system configurations of the connection method applicable to TP10 series and cable creation method	TP10LJFF
TP Software Basic Operation/Data Transfer Manual (For TP10 Series) (sold separately) *1	Describes methods of the TP Software installation operation, basic operation for drawing and transmitting data to TP10 series	TP10RJAZ
TP Software Basic Operation/Data Transfer Manual (For TP10 Series) (sold separately) *1	Describes specifications and settings of the object functions used in TP Software	TP10RJSC

*1 Stored in the TP Software in PDF format

For details of a PLC to be connected, refer to the PLC user's manual respectively.

Bundled Items

Model Name	Remark
TP1030-LBD-24V	HMI main unit
TP1030-LBL-5V	(The maintenance supplies are packed with the product.)

Maintenance Supplies	Quantity	Maintenance Supplies	Quantity
PLC Communication connector	1	Panel Mounting Packing	1
Panel Mounting Bracket (with M4 ×20 screws)	4	TP10 General Description (This manual)	1
Connection cable for HMI and PLC (TP1-PLC-R4-8P)			1

Explanation of the HMI model name

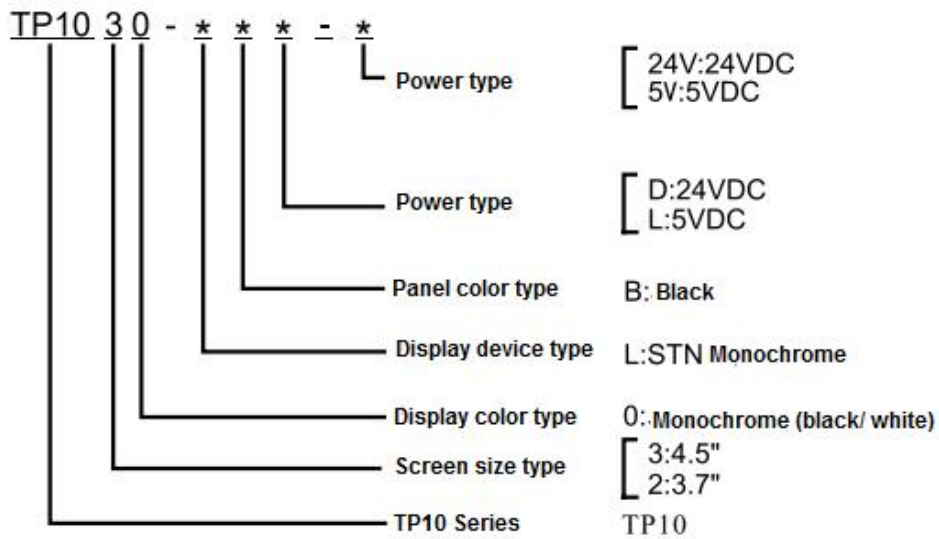

1. Specification

1.1 General Specifications

Items		Specification					
		TP1030-LBD-24V/ LBL-5V					
Operating ambient temperature	Display section	0 to 50°C					
	Other display section	0 to 55°C (When mounted horizontally), 0 to 50°C (When mounted vertically)					
Storage ambient temperature		-20 to 60°C					
Operating ambient humidity		10 to 90% RH, non-condensing (The wet bulb temperature is 39°C or less.)					
Storage ambient humidity		10 to 90% RH, non-condensing (The wet bulb temperature is 39°C or less.)					
Vibration resistance		Conforms to JIS B3502 and IEC61131-2	Frequency	Acceleration	Half-amplitude	Sweep count	
		Under intermittent vibration	5 to 9Hz	--	3.5mm	10 times each in X, Y and Z directions	
			9 to 150Hz	9.8m/s ²	--		
			Under continuous vibration	5 to 9Hz	--		1.75mm
				9 to 150Hz	4.9m/s ²		--
Shock resistance		Conforms to JIS B3502, IEC 61131-2 (147m/s ² , 11 ms, Sine half-wave pulse, 3 times each in the X, Y, and Z directions.)					
Operating atmosphere		Must be free of lampblack, corrosive gas, flammable gas, or excessive amount of electroconductive dust particles and must be no direct sunlight. (Same as for saving)					
Operating altitude ^{*1}		2000 m (6562 ft) max.					
Installation location		Inside control panel					
Overvoltage category ^{*2}		II or less					
Pollution degree ^{*3}		2 or less					

Cooling method	Self-cooling
----------------	--------------

*1 Do not use or store the HMI under pressure higher than the atmospheric pressure of altitude 0m (0ft.). Failure to observe this instruction may cause a malfunction.

*2 This indicates the section of the power supply to which the equipment is assumed to be connected between the public electrical power distribution network and the machinery within the premises.

Category II applies to equipment for which electrical power is supplied from fixed facilities.

The surge voltage withstand level for up to the rated voltage of 300 V is 2500 V.

*3 This index indicates the degree to which conductive material is generated in the environment where the equipment is used. In pollution degree 2, only non-conductive pollution occurs but temporary conductivity may be produced due to condensation.

1.2 Performance specification

Items		Specifications	
		TP1030-LBD-24V	TP1030-LBL-5V
Display section* ¹	Type	STN monochrome (white/black) liquid crystal	
	Screen size	3.7"	
	Resolution	160W × 64H dots(Horizontal format)	
	Display size	W86.4(3.4) × H34.5(1.35) [mm](inch) (Horizontal format)	
	Display character	16-dot standard font: 20 characters ×4 lines(Horizontal format)	
	Display color	Monochrome (white/black)	
	Display angle	Left/Right: 30 degrees, Top: 20 degrees, Bottom: 30 degrees (Horizontal format)	
	Contrast adjustment	16-level adjustment	
	Intensity of LCD only	200 [cd/m ²] (in green)	
	life	Approx.50,000h. (Time for display intensity to become 1/5 at operating ambient temperature of 25°C)	
Backlight (No replacement required)		LED with 3 available colors (green, red, orange)	
		Backlight status (colors, ON/BLINK/OFF) control, Adjustable screensaver activation time	
		Setting the system information enables* ² PLC to control the backlight status	
Touch panel	Number of touch keys	Maximum 50 keys/screen (Matrix resistive film touch panel)	
	Key size	Minimum 2 ×2 dots (per key)	
	Simultaneous pressing of two (or more) areas	Enable	
	Life	1 million times or more (operating force 0.98N max.)	
Buzzer output (a buzzer that sounds when touch keys are pressed)		Single tone (LONG/ SHORT/Customizing are not allowed.)	
Memory	User memory* ³	Flash memory ROM (Internal), for storing Project data (512Kb or less), OS	
	Life	100,000 times	

	(Number of write times)	
Battery		GT11-50BAT lithium battery
	Backup target	Clock data, alarm history and recipe data
	Life	Approx. 5 years (Operating ambient temperature of 25)
Environmental protective structure ^{*4}		Equivalent to IP67 (JEM1030) (front section)
External dimensions		W145(5.7) ×H76(2.99) ×D29.5(1.16)[mm](inch) (Horizontal format)
Panel cutting dimensions		W137 (5.39) ×H66 (2.59) [mm] (inch) (Horizontal format)
Weight	0.3 kg (Excluding mounting fixtures)	0.28 kg(Excluding mounting fixtures)
Compatible software package		TP Software 2.0 or later

*1 Bright dots(always lit) and dark dots(unlit) may appear on a liquid crystal display panel. It is impossible to completely avoid this symptom, as the liquid crystal display comprises of a great number of display elements. Flickers may be observed depending on the display color.

Please note that these dots appear due to its characteristics and are not caused by product defect.

When the same screen is displayed for a long time, an incidental color or partial discoloration is generated on the screen due to heat damage, and it may not disappear.

To prevent heat damage, the screen saver function is effective.

For details of the screen saver function, refer to the following.

→HMI User's Manual

*2 For the details of system information, refer to the following.

→TP Software Screen Designer Manual

*3 ROM in which new data can be written without deleting the written data.

*4 Note that this does not guarantee all users' operation environment.

1.3 Communication specification

Items		Specification
		TP1020-LBD-24V/ LBL-5V
Built-in interface	PLC Communication	RS-422/ 485, 1 channel Transmission speed: 115,200/57,600/38,400/19,200/9,600/4,800bps Connector shape: Connector terminal block 9-pins
	PC Communication ^{*1}	RS-232, 1 channel Transmission speed: 115,200/57,600/38,400/19,200/9,600/4,800bps MINI DIN 6-pins (Female)

*1 Project data upload/download, OS installation, Transparent function

1.4 Power supply specification

(For details on power supply wiring, such as the allowable cable size and tightening torque, refer to the additional manual, "TP10 User's Manual".)

Items	Specification	
	TP1030-LBD-24V	TP1030-LBL-5V
Input power supply voltage	24VDC (+10% -15%), ripple voltage 200mV or less	5V DC(±5%), supplied from PLC

Fuse (Built-in, not exchangeable)	0.5A	--
Power consumption	2.2W (90mA/24VDC) or less	1.1W (220mA/5VDC) or less
At backlight off	1.7W (70mA/24VDC) or less	0.6W (120mA/5VDC) or less
Inrush current	13A or less (26.4VDC) 1ms	--
Permissible instantaneous power failure time ^{*1}	Within 5ms	--
Noise immunity	Noise voltage: 1000Vp-p, Noise width: 1μs (by noise simulator of 30 to 100Hz noise frequency)	
Dielectric withstand voltage	500VAC for 1 minute (between the HMI's power supply terminals and the HMI's grounding terminal)	--
Insulation resistance	10MΩ or larger by 500VDC insulation resistance tester (between the HMI's power supply terminals and the HMI's grounding terminal)	--
Grounding	Class D grounding (100Ω or less). To be connected to the panel when grounding is not possible	--

*1 The HMI continues to operate even upon 5ms or shorter instantaneous power failure.

The HMI stops operating if there is extended power failure or voltage drop, while it automatically resumes operation as soon as the power is restored

2. Wiring of connection cables

The diagram below shows cable assignment for HMI port.

Cables: TP10-PLC-R4-8P-□M

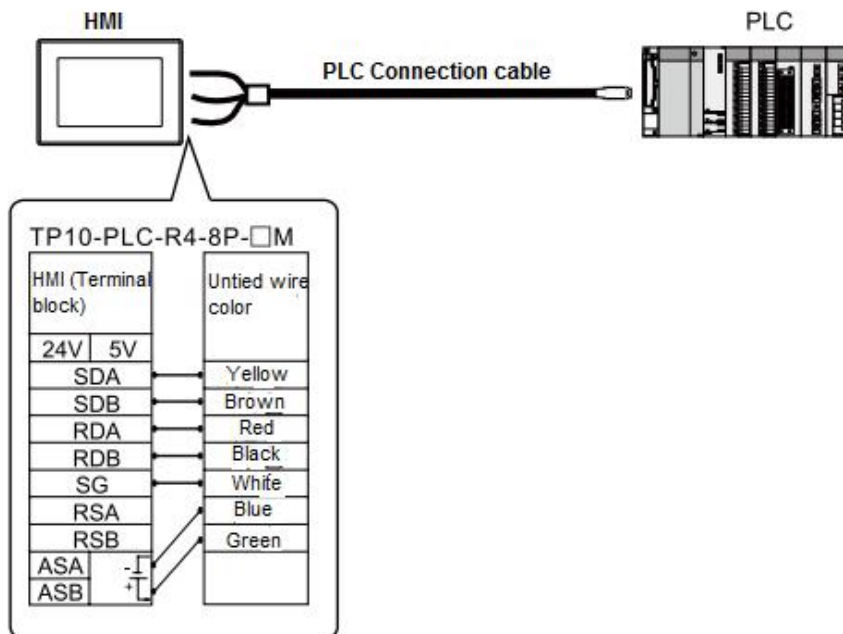

User-made cable is necessary, depending on the PLC.

For the detail, refer to TP10 Series Connection Manual.

Cable jacket to remove	7mm (0.27")
Tightening torque	0.22 to 0.25 N•m

Recommended tool (Screwdriver)	SZS 0.4 ×2.5 (Phoenix Contact Inc.)
-----------------------------------	--

This manual confers no industrial property rights or any rights of any other kind, nor does it confer any patent licenses. HCFA cannot be held responsible for any problems involving industrial property rights which may occur as a result of using the contents used in this manual.

Warranty

HCFA will not be held liable for damage caused by factors found not to be the cause of HCFA; opportunity loss or lost profits caused by faults in the HCFA products; damage, secondary damage, accident compensation caused by special factors unpredictable by HCFA; damages to products other than HCFA products; and to other duties.

 For safe use
<ul style="list-style-type: none"> • This product has been manufactured as a general-purpose part for general industries, and has not been designed to or manufactured to be incorporated in a device or system used in purpose related to human life. • Before using this product for special purposes such as nuclear power, electric power, aerospace, medicine or passenger movement vehicles, consult with HCFA. • This product has been manufactured under strict quality control. However, when installing the product where major accidents or losses could occur if the product fails, install appropriate backup or failsafe functions in the system.