

Modicon M340, Premium, Atrium, and Quantum Using Unity Pro Communication Services and Architectures Reference Manual

10/2014

The information provided in this documentation contains general descriptions and/or technical characteristics of the performance of the products contained herein. This documentation is not intended as a substitute for and is not to be used for determining suitability or reliability of these products for specific user applications. It is the duty of any such user or integrator to perform the appropriate and complete risk analysis, evaluation and testing of the products with respect to the relevant specific application or use thereof. Neither Schneider Electric nor any of its affiliates or subsidiaries shall be responsible or liable for misuse of the information contained herein. If you have any suggestions for improvements or amendments or have found errors in this publication, please notify us.

No part of this document may be reproduced in any form or by any means, electronic or mechanical, including photocopying, without express written permission of Schneider Electric.

All pertinent state, regional, and local safety regulations must be observed when installing and using this product. For reasons of safety and to help ensure compliance with documented system data, only the manufacturer should perform repairs to components.

When devices are used for applications with technical safety requirements, the relevant instructions must be followed.

Failure to use Schneider Electric software or approved software with our hardware products may result in injury, harm, or improper operating results.

Failure to observe this information can result in injury or equipment damage.

© 2014 Schneider Electric. All rights reserved.

Table of Contents



	Safety Information	7
	About the Book	9
Part I	Introduction to the Communication Application	13
Chapter 1	General	15
	Introduction to the Communication Application	16
	Summary of Communication Solutions	18
Chapter 2	Services Available on Networks and Buses	19
2.1	Global Data Service	20
	Global Data Service	20
2.2	IO Scanning Service	22
	IO Scanning Service	22
2.3	Peer Cop Service on Modbus Plus	24
	Peer Cop Service	24
2.4	Common Words and Shared Tables Services on Fipway	27
	Fipway Common Words and Shared Tables	27
2.5	Messaging Service	28
	Messaging Service	29
	Characteristics of the Messaging Service Communication Functions	30
Chapter 3	Interoperability	37
	List of Modbus Function Codes	37
Chapter 4	Communication Architectures	41
	Global Architecture	42
	Network Architectures	46
	Fieldbus	50
Chapter 5	X-Way Message Routing	51
	General	52
	Features	53
	Main Address	55
	Multi-Module Station Addresses	56
	Messaging	57
Part II	Addressing	59
Chapter 6	General Points Concerning Addressing	61
	General	61

Chapter 7	IP Addressing	63
	Note on IP Addressing	63
Chapter 8	Modbus Plus Addressing	67
	Addressing for a Modbus Plus Communication Entity	67
Chapter 9	X-Way Addressing	71
	Addressing for a Communication Entity	72
	Types of Communication Entities	74
	Processor Communication Channel Addressing	76
	Addressing for a TSX SCY 21601 Communication Module	78
	Examples of Intra-Station Addressing: Uni-Telway Addressing	79
	Examples of Intra-Station Addressing: Fipio Addressing	81
	Examples of Intra-Station Addressing	82
Chapter 10	Modicon M340 PLCs Addressing	85
	Modicon M340 Types of Communication Entities	86
	Modicon M340 Addressing for a Communication Entity	87
	Processor Communication Channels Addressing	90
	Example of Modicon M340 Ethernet Addressing	92
	Example of Modicon M340 CANopen Addressing	93
	Examples of Modicon M340 Modbus and Character Mode Addressing	94
	Examples of Modicon M340 Communication EFs Addressing	96
Chapter 11	General points concerning bridging	99
	Bridging Description	100
	Bridging Example	102
Part III	Operating Modes	105
Chapter 12	Network Configuration	107
	Network Configuration Principle Using Unity Pro	108
	Creating a Logic Network	109
	Configuring a Logic Network	111
	Associating a Logic Network with Network Hardware	112
Chapter 13	Bus Configuration	115
	Creating and Accessing RIO\DIO Field Buses	116
	Accessing Bus Configurations on PCMCIA and SCY 21601 Cards ..	122
Chapter 14	Configuration of X-Way Routing Premium Stations ..	125
	Configuration	126
	Configuration of Multi-Network Services	127
	Configuring an X-Way Router Module	129
	Examples of X-Way Routing Stations	133
	Examples of Partial Routing	137

Chapter 15	Debugging	141
	Description of the Communication Debug Screens	141
Chapter 16	Communication Function Programming and Entry Help	145
	Communication Function Entry Help	146
	Access a specific instruction of the function, function block or DFB type	147
	Address Entry Help	149
Index	153

Safety Information



Important Information

NOTICE

Read these instructions carefully, and look at the equipment to become familiar with the device before trying to install, operate, or maintain it. The following special messages may appear throughout this documentation or on the equipment to warn of potential hazards or to call attention to information that clarifies or simplifies a procedure.



The addition of this symbol to a “Danger” or “Warning” safety label indicates that an electrical hazard exists which will result in personal injury if the instructions are not followed.



This is the safety alert symbol. It is used to alert you to potential personal injury hazards. Obey all safety messages that follow this symbol to avoid possible injury or death.

DANGER

DANGER indicates a hazardous situation which, if not avoided, **will result in** death or serious injury.

WARNING

WARNING indicates a hazardous situation which, if not avoided, **could result in** death or serious injury.

CAUTION

CAUTION indicates a hazardous situation which, if not avoided, **could result in** minor or moderate injury.

NOTICE

NOTICE is used to address practices not related to physical injury.

PLEASE NOTE

Electrical equipment should be installed, operated, serviced, and maintained only by qualified personnel. No responsibility is assumed by Schneider Electric for any consequences arising out of the use of this material.

A qualified person is one who has skills and knowledge related to the construction and operation of electrical equipment and its installation, and has received safety training to recognize and avoid the hazards involved.

About the Book



At a Glance

Document Scope

This manual gives an overview of the communication services and architectures for use with Schneider PLCs programmed using Unity Pro software.

Validity Note

This documentation is valid for Unity Pro V8.1 or later.

The technical characteristics of the devices described in this document also appear online. To access this information online:

Step	Action
1	Go to the Schneider Electric home page www.schneider-electric.com .
2	In the Search box type the reference of a product or the name of a product range. <ul style="list-style-type: none">• Do not include blank spaces in the model number/product range.• To get information on grouping similar modules, use asterisks (*).
3	If you entered a reference, go to the Product Datasheets search results and click on the reference that interests you. If you entered the name of a product range, go to the Product Ranges search results and click on the product range that interests you.
4	If more than one reference appears in the Products search results, click on the reference that interests you.
5	Depending on the size of your screen, you may need to scroll down to see the data sheet.
6	To save or print a data sheet as a .pdf file, click Download XXX product datasheet .

The characteristics that are presented in this manual should be the same as those characteristics that appear online. In line with our policy of constant improvement, we may revise content over time to improve clarity and accuracy. If you see a difference between the manual and online information, use the online information as your reference.

Related Documents

Title of Documentation	Reference Number
Premium and Atrium Using Unity Pro, Ethernet Network Modules, User Manual	35006192 (Eng), 35006193 (Fre), 35006194 (Ger), 31007214 (Ita), 35006195 (Spa), 31007102 (Chs)
Premium and Atrium Using Unity Pro, Modbus Plus Network, User Manual	35006188 (Eng), 35006189 (Fre), 35006190 (Ger), 35013962 (Ita), 35006191 (Spa), 35013963 (Chs)
Premium and Atrium Using Unity Pro, Fipway Network, User Manual	35006183 (Eng), 35006185 (Fre), 35006186 (Ger), 35013955 (Ita), 35006187 (Spa), 35013956 (Chs)
Premium and Atrium Using Unity Pro, Fipio Bus, Setup Manual	35008155 (Eng), 35008156 (Fre), 35008157 (Ger), 35013953 (Ita), 35008158 (Spa), 35013954 (Chs)
Premium and Atrium Using Unity Pro, AS-i Bus, User Manual	35006196 (Eng), 35006197 (Fre), 35006198 (Ger), 35013927 (Ita), 35006201 (Spa), 35013928 (Chs)
Premium and Atrium Using Unity Pro, Asynchronous Serial Link, User Manual	35006178 (Eng), 35006179 (Fre), 35006180 (Ger), 35013959 (Ita), 35006181 (Spa), 35013960 (Chs)

Title of Documentation	Reference Number
Modicon M340 for Ethernet, Communications Modules and Processors, User Manual	31007131 (Eng), 31007132 (Fre), 31007133 (Ger), 31007494 (Ita), 31007134 (Spa), 31007493 (Chs)
AS-Interface Bus for Modicon M340, User Manual	EIO0000000138 (Eng), EIO0000000139 (Fre), EIO0000000140 (Ger), EIO0000000142 (Ita), EIO0000000141 (Spa), EIO0000000143 (Chs)
Modicon M340 with Unity Pro, Serial Link, User Manual	35012430 (Eng), 35012432 (Fre), 35012431 (Ger), 35013363 (Ita), 35012433 (Spa), 35012434 (Chs)
Quantum with Unity Pro, TCP/IP Configuration, User Manual	33002467 (Eng), 33002468 (Fre), 33002469 (Ger), 31008078 (Ita), 33002470 (Spa), 31007110 (Chs)
Quantum with Unity Pro, Modbus Plus Network Modules, User Manual	35010487 (Eng), 35010488 (Fre), 35010489 (Ger), 35013961 (Ita), 35010490 (Spa), 35012186 (Chs)
Quantum with Unity Pro, 140 EIA 921 00 AS-I Bus Interface Module, User Manual	35012420 (Eng), 35012421 (Fre), 35012422 (Ger), 35013929 (Ita), 35012424 (Spa), 35013930 (Chs)

You can download these technical publications and other technical information from our website at www.schneider-electric.com.

Part I

Introduction to the Communication Application

Subject of this Part

This part gives an overview of the communication application: the types of networks and buses, services and architectures available.

What Is in This Part?

This part contains the following chapters:

Chapter	Chapter Name	Page
1	General	15
2	Services Available on Networks and Buses	19
3	Interoperability	37
4	Communication Architectures	41
5	X-Way Message Routing	51

Chapter 1

General

Subject of this Chapter

This chapter gives an overview of the different characteristics of the communication application.

What Is in This Chapter?

This chapter contains the following topics:

Topic	Page
Introduction to the Communication Application	16
Summary of Communication Solutions	18

Introduction to the Communication Application

At a Glance

The communication application makes it possible to exchange data between different devices connected to a bus or a network.

This function applies to :

- processors with an Ethernet, Modbus, built-in Fipio or CANopen link,
- specific rack-mounted communication modules,
- the terminal port of a processor,
- PCMCIA cards of a rack-mounted processor or module.

Communication Types

The different communication types are:

- TCP/IP or Ethway Ethernet Network
- Fipway Network
- Modbus Plus Network
- Fipio bus (manager and agent)
- Uni-Telway bus
- Modbus/JBus bus
- Character mode serial link
- CANopen field bus
- Interbus field bus
- Profibus field bus
- The USB-standard fast terminal port

Available Services

The available services can be classified into three categories:

- Explicit messaging (*see page 28*) services:
 - Modbus messaging
 - UNI-TE messaging
 - telegrams
- Implicit database access services:
 - global data (*see page 20*)
 - common words (*see page 27*)
 - shared tables (*see page 27*)
- Implicit Input/Output management services:
 - I/O scanning (*see page 22*)
 - peer cop (*see page 24*)

WARNING

UNEXPECTED APPLICATION BEHAVIOR - DATA EXCHANGE COMPATIBILITY

Data structure alignments are not the same for Premium/Quantum and M340 PLCs so verify that the data exchanged are compatible.

See the page DDT: Mapping rules (see *Unity Pro, Program Languages and Structure, Reference Manual*) for more information.

Failure to follow these instructions can result in death, serious injury, or equipment damage.

Characteristics of the Different Service Types

The following table gives an overview of the main characteristics of the types of services mentioned above:

Type of service	These services make it possible ...	They are used ...
Messaging services	for a device (Client) to send a message to another device (Server) and obtain a response without having to program anything into the server device.	to access data from time to time.
Implicit database access services	to share data which is refreshed automatically and on a regular basis.	to synchronize applications or to transparently obtain real-time images of a system on several remote PLCs
Implicit I/O management services	to transparently and automatically manage remote I/Os on a network.	to monitor a set of distributed systems across a network.

Summary of Communication Solutions

At a Glance

The services presented earlier in this chapter are available for certain types of communication. For example, for messaging services, certain communication functions apply to networks, others to buses and others to serial links in character mode ([see page 34](#)).

Summary

The following table gives an overview of the different services available according to the types of communication:

Function	Fipway	Fipio	Uni-Telway	Character mode	Modbus/Jbus	Modbus Plus	Ethway	TCP/IP	CANopen	USB
Messaging services										
Communication functions	The communication functions that can be used depend closely on the type of communication for which they are applied (see page 34).									
Implicit database access services										
Global Data	-	-	-	-	-	-	-	X	-	-
Common words	X	-	-	-	-	-	X	-	-	-
Shared tables	X	-	-	-	-	-	X	-	-	-
Periodic data exchanges	-	X	-	-	-	-	-	-	-	-
Implicit I/O management services										
I/O Scanning	-	-	-	-	-	-	-	X	-	-
Peer cop	-	-	-	-	-	X	-	-	-	-
Other	-	X	-	-	-	X	-	-	X	-
Legend:										
X	Yes									
-	No									

Chapter 2

Services Available on Networks and Buses

Subject of this Chapter

This chapter describes the different services available on the communication buses and networks.

What Is in This Chapter?

This chapter contains the following sections:

Section	Topic	Page
2.1	Global Data Service	20
2.2	IO Scanning Service	22
2.3	Peer Cop Service on Modbus Plus	24
2.4	Common Words and Shared Tables Services on Fipway	27
2.5	Messaging Service	28

Section 2.1

Global Data Service

Global Data Service

At a Glance

The aim of the **Global Data** service, which is supported by Ethernet modules, is to provide an automatic data exchange for the coordination of PLC applications. Data is shared according to an inter-device publication/subscription method.

How it Works

The communication modules are grouped into a **Distribution group**.

Each communication module publishes a local application variable for the other communication modules in the distribution group.

Each communication module can also subscribe to the application variables published by all other modules belonging to the distribution group.

The **Global Data** service should be configured to determine the location and the number of application variables of each communication module. Once the modules have been configured, exchanges between communication modules belonging to the same group are automatically carried out when the PLC is in RUN mode.

Illustration:

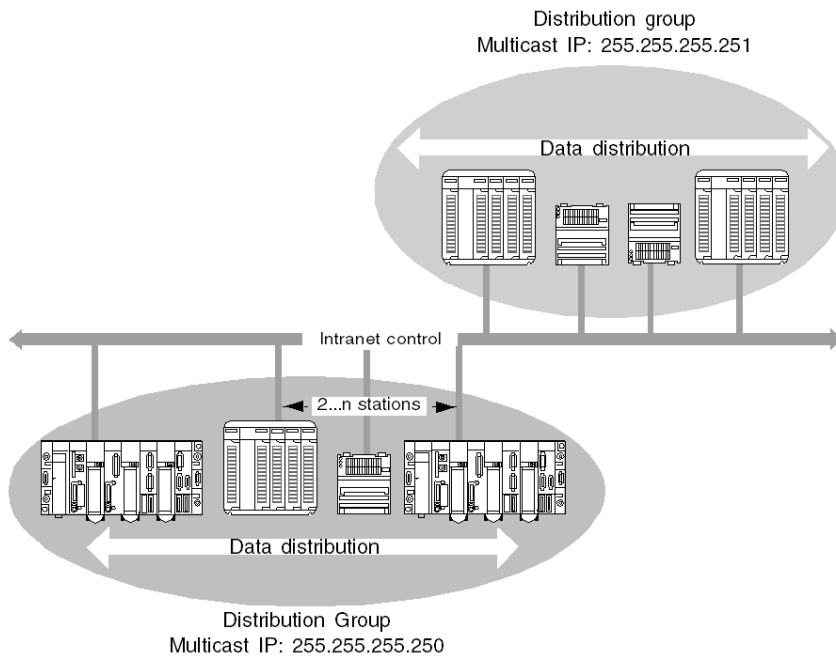

A **Distribution group** is a group of communication modules identified by the same **multicast IP** address. Exchanges in "multicasting" are used to distribute **Global Data**. Several independent distribution groups can co-exist on the same subnetwork with their own multicast address.

A Publication/Subscription protocol on UDP/IP is used for data distribution.

Limitations

- There is no theoretical limit to the number of stations that may belong to a distribution group. The main limitation is the number of variables exchanged in a group (64 variables).
- Replacing a 140 NOE 771 x0 module by a new 140 NOE 771 x1 module, the Global Data Service must not be configured by web pages. Otherwise, the Global Data Utility will start even if Global Data has not been configured in the application.

Section 2.2

IO Scanning Service

IO Scanning Service

At a Glance

The IO scanner makes it possible to periodically read or write to/from remote inputs/ouputs on the Ethernet network, without requiring any specific programming.

This service comprises the following essential elements:

- a read field containing all the values of the remote inputs,
- a write field containing all the values of the remote outputs,
- scanning periods independent of the PLC cycle and dedicated to checking each remote device.

How it Works

The scan will only be performed if the PLC is in Run mode.

This service works with all devices supporting Modbus communication on the TCP/IP profile in server mode.

The exchange mechanism, which is transparent for users, involves:

- read requests,
- write requests,
- read and write requests.

Section 2.3

Peer Cop Service on Modbus Plus

Peer Cop Service

At a Glance

The Peer Cop service is a mechanism for automatic exchange between stations connected on the same Modbus Plus segment.

This service makes it possible to control remote inputs / outputs on a continuous basis by implicit exchanges.

Premium and Quantum PLCs are capable of managing this service on a Modbus Plus network

Premium PLCs support two types of Peer Cop transfer:

- specific inputs,
- specific outputs.

Specific Inputs and Outputs

Specific inputs and outputs are point-to-point services using the multicast (multi-station) protocol. Each message contains one or more destination addresses for data transmission. This mode of operation makes it possible to exchange data with several stations without them having to be repeated.

Report

Three types of report are associated with specific inputs and outputs:

- An activity bit provides information on the availability and validity of the status bits.
- Status bits (one bit per station):
 - ensure consistency between the number of specific inputs configured and the number of specific inputs received,
 - indicate if the specific inputs have been received before the Timeout.
- Presence bits (one bit per station) indicate if the specific inputs have been refreshed.

NOTE: The presence bits are only valid for the specific inputs.

Example for the Inputs

The data blocks are copied in their entirety from the PCMCIA communication card to the internal word space, reserved at the time of configuration.

In the following example, the address of the first internal word is %MW10:

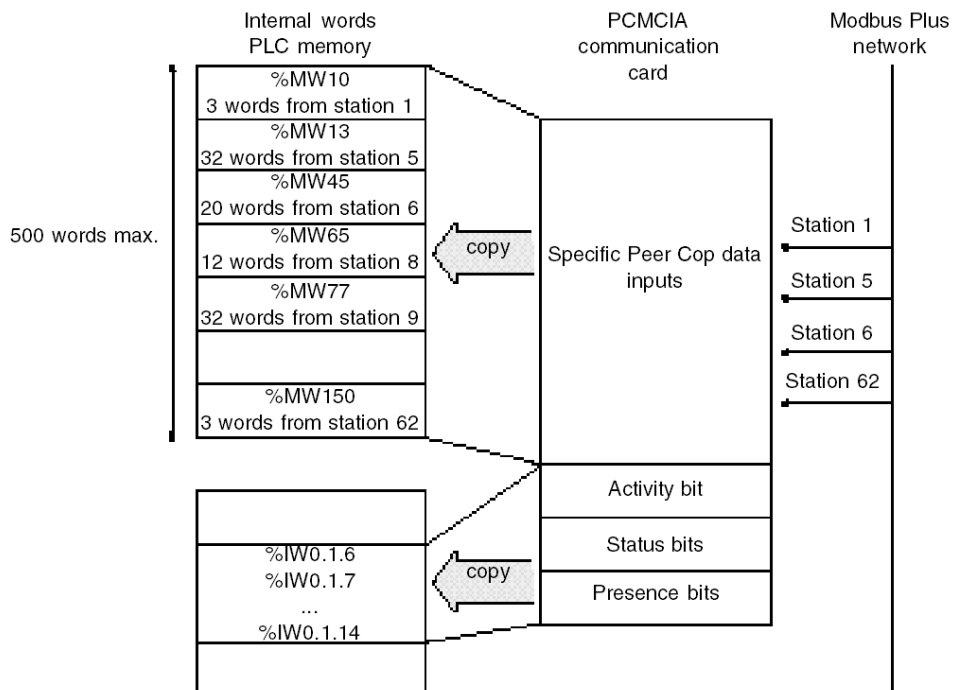

Example for the Outputs

The data blocks are copied in their entirety from the internal word space, reserved at the time of configuration, to the PCMCIA communication card. The reports are copied from the PCMCIA communication card to the language objects.

In the following example, the address of the first internal word is %MW10:

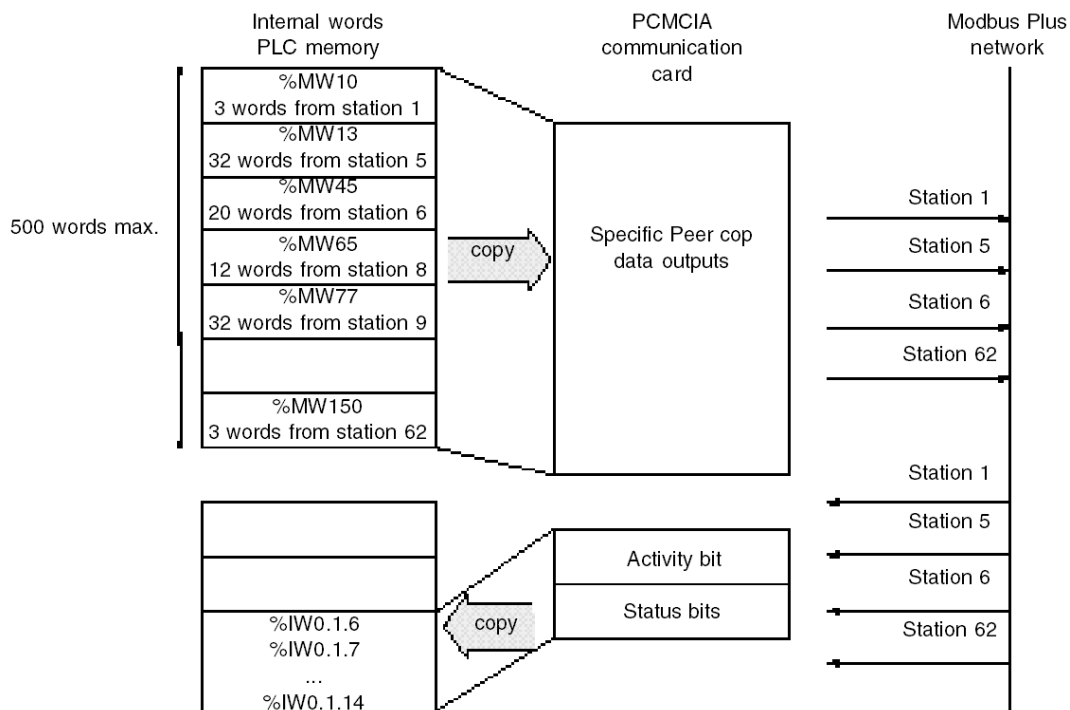

Section 2.4

Common Words and Shared Tables Services on Fipway

Fipway Common Words and Shared Tables

At a Glance

The Fipway network provides two data sharing services:

- common words,
- shared table.

The main objective of these two services is to synchronize automation applications.

Common Words

The common words service consists of a set of dedicated %NW words. Each station on the network can, depending on its software configuration, access the database in read or write mode.

Updates are performed implicitly at the start of the cycle for read operations and at the end of the cycle for write operations. The function of the application program is simply to read or write these words.

The addressing of the words is as follows: %NWn.s.k

The following table states the address parameters of the common words:

Parameter	Description
n	Network number
s	Station number
k	Word number

NOTE: The network number makes it possible to select the network on which the common words are exchanged in a multi-network configuration.

Shared Table

This service makes it possible to exchange a table of %MW internal words divided up into as many fields as there are stations on the Fipway network. The principle is based on each PLC broadcasting a word memory field to the other stations on the network.

Updates are performed implicitly and independently of the application program's execution cycle. The function of the program is simply to write or read the %MW words.

NOTE: When configuring and assigning fields, be careful to avoid creating memory conflicts between stations.

Section 2.5

Messaging Service

Subject of This Section

This section gives an overview of the messaging service available on Schneider Electric PLCs.

What Is in This Section?

This section contains the following topics:

Topic	Page
Messaging Service	29
Characteristics of the Messaging Service Communication Functions	30

Messaging Service

At a Glance

The messaging service makes it possible to perform inter-PLC data exchanges using communication functions.

Two types of messaging are used:

- Private: UNI-TE on Modicon Premium and Telemecanique installed base,
- Standard: Modbus on Modicon Quantum, Modicon Premium, Modicon M340, Modicon M580, and Modicon installed base.

The destination entities of an exchange can either be located in a local station or in a remote station on a communication channel or directly in the CPU.

The communication functions provide an interface that is independent of the location of the destination entity. Furthermore, they mask the coding of the communication requests from the user. They thus provide compatibility of communication between Premium, Micro, Quantum, TSX 40, TSX 17, 1000 series and Modicon M340 PLCs.

NOTE: Processing of communication functions is asynchronous in relation to the processing of the application task which allowed them to be activated. The send/receive telegram and stop operation functions are the only exceptions as their execution is synchronous with the execution of the activation task.

Synchronous/Asynchronous Communication

A communication function is said to be synchronous when it is wholly executed during the PLC task that activated it.

A communication function is said to be asynchronous when it is executed during one or more PLC tasks after the task that activated it.

Characteristics of the Messaging Service Communication Functions

At a Glance

These functions (see *Unity Pro, Communication, Block Library*) enable communication between one device and another. Certain functions are common to several types of communication channel. Others may be specific to one communication function.

NOTE: Processing of communication functions is asynchronous in relation to the processing of the application task, which allowed them to be activated. The send/receive telegram and stop operation functions are the only exceptions as their execution is synchronous with the execution of the activation task.

NOTE: It is recommended that asynchronous functions be triggered on edge and not on state to avoid sending several identical requests in quick succession, thus saturating the communication buffers.

Messaging Service Communication Functions on Modicon M340 Platform

The following table gives an overview of Modicon M340 platform messaging service functions:

Function	Role
DATA_EXCH	Transmit or receive data.
ETH_PORT_CTRL	Activate or deactivate a protocol.
INPUT_BYTE	Receive an array of bytes on a character mode link of a BMX NOM module in a local rack or linked to a CPU embedded communication channel.
INPUT_CHAR	Receive a character string on a character mode link of a BMX NOM module in a local rack or linked to a CPU embedded communication channel.
PRINT_CHAR	Send a character string on a character mode link of a BMX NOM module in a local rack or linked to a CPU embedded communication channel.
READ_VAR	Read the value of one or more language objects via a communication module in a local rack or linked to a CPU embedded communication channel.
SEND_EMAIL	Send an email over an Ethernet port of a communication module plugged in a local rack.
WRITE_VAR	Write the value of one or more language objects via a communication module in a local rack or linked to a CPU embedded communication channel.

Messaging Service Communication Functions on Modicon M580 Platform

The following table gives an overview of the Modicon M580 platform messaging service functions:

Function	Role
DATA_EXCH	End any requests (Modbus, Umas ...) to any Modbus slave via a communication module plugged in a local rack or in an EIO drop.
GET_TS_EVT_M	Get the time stamped data in a Modicon BMX ERT 1604T or BMX CRA module plugged in a local rack or in an EIO drop.
INPUT_BYTE	Receive an array of bytes on a character mode link of a BMX NOM module plugged in a local rack or in an EIO drop.
INPUT_CHAR	Receive a character string on a character mode link of a BMX NOM module plugged in a local rack or in an EIO drop.
PRINT_CHAR	Send a character string on a character mode link of a BMX NOM module plugged in a local rack or in an EIO drop.
READ_PARAM_MX	Read the parameter words of an X80 I/O module plugged in a local rack by performing an explicit exchange.
READ_STS_MX	Read the status words of an X80 I/O module plugged in a local rack or in an EIO drop by performing an explicit exchange.
READ_VAR	Read the value of one or more language objects via a communication module plugged in a local rack or in an EIO drop.
RESTORE_PARAM_MX	Restore the parameter words of an X80 I/O module plugged in a local rack by performing an explicit exchange.
SAVE_PARAM_MX	Save the parameter words of an X80 I/O module plugged in a local rack by performing an explicit exchange.
SEND_EMAIL	Send an email over an Ethernet port of a communication module plugged in a local rack (Ethernet modules cannot be plugged in an EIO drop).
WRITE_CMD_MX	Send a command to an X80 I/O module plugged in a local rack or in an EIO drop by performing an explicit exchange.
WRITE_PARAM_MX	Write the parameter words of an X80 I/O module plugged in a local rack by performing an explicit exchange.
WRITE_VAR	Write the value of one or more language objects via a communication module plugged in a local rack or in an EIO drop.

Messaging Service Communication Functions on Modicon Quantum Platform

The following table gives an overview of Modicon Quantum platform messaging service functions:

Function	Role
CREAD_REG	Continuously read a register area from a slave addressed via Modbus Plus, TCP/IP-Ethernet or SY/MAX-Ethernet
CWRITE_REG	Continuously write a register area to a slave addressed via Modbus Plus, TCP/IP-Ethernet or SY/MAX-Ethernet
EXCH_QX	Perform data transfers through an EIO bus to and from Modbus slaves connected to a Modicon M340 rack
INPUT_CHAR_QX	Receive a character string from a Modicon M340 serial communication module through an EIO bus
MBP_MSTR	Perform various network communication operations on Modbus Plus, TCP/IP-Ethernet or SY/MAX-Ethernet
PRINT_CHAR_QX	Send a character string of 1000 bytes maximum from a Modicon M340 Modbus master through an EIO bus
READ_REG	Read a register area from a slave addressed via Modbus Plus, TCP/IP-Ethernet or SY/MAX-Ethernet
READ_REG_QX	Read registers in a Modbus slave connected to a Modicon M340 Modbus master through an EIO bus
READ_STS_QX	Read the status words of a Modicon M340 Ethernet I/O module by performing an explicit exchange with the processor memory
WRITE_CMD_QX	Send a command to a Modicon M340 Ethernet I/O module with a command word by performing an explicit exchange
WRITE_REG	Write a register area to a slave addressed via Modbus Plus, TCP/IP-Ethernet or SY/MAX-Ethernet
WRITE_REG_QX	Write registers in a Modbus slave connected to a Modicon M340 Modbus master through an EIO bus
XXMIT	Modbus messages from master PLC and ASCII input/output strings.

Messaging Service Communication Functions on Modicon Momentum Platform

The following table gives an overview of Modicon Momentum platform messaging service functions:

Function	Role
MBP_MSTR	Perform various network communication operations on Modbus Plus, TCP/IP-Ethernet or SY/MAX-Ethernet.
XMIT	Modbus messages from master PLC and ASCII input/output strings.
XXMIT	Modbus messages from master PLC and ASCII input/output strings.

Messaging Service Communication Functions on Modicon Premium Platform

The following table gives an overview of Modicon Premium platform messaging service functions:

Function	Role
DATA_EXCH	Send/request receipt of data.
INPUT_BYTE	Read an array of bytes.
INPUT_CHAR	Read a character string.
OUT_IN_CHAR	Send a character string and wait for a response.
OUT_IN_MBUS	Emulate a Modbus master communication from a serial link configured in character mode.
PRINT_CHAR	Write a character string.
RCV_TLG	Receive a telegram.
READ_ASYN	Read 1 Kbyte of messaging.
READ_GDATA	Read common Modbus Plus data.
READ_VAR	Read standard language objects: internal words and bits, system words and bits, timers, monostables, drums, registers, counters.
SEND_REQ	Send UNI-TE requests.
SEND_TLG	Send a telegram.
UNITE_SERVER	Process immediately READ_VAR and WRITE_VAR requests on Modbus (Immediate server).
WRITE_ASYN	Write 1 Kbytes of messaging.
WRITE_GDATA	Write common Modbus Plus data.
WRITE_VAR	Write standard language objects: internal words and bits, system words and bits.

Availability of Functions According to Protocols

Protocols supported by the messaging service functions in a Modicon M340 platform:

Function	TCP/IP	ETHWAY	CANopen	Modbus serial	Modbus Plus	Fipway	Uni- Telway	Fipio	Character mode
DATA_EXCH	X	-	X	X	-	-	-	-	X
ETH_PORT_CTRL	X	-	-	-	-	-	-	-	-
INPUT_BYTE	-	-	-	-	-	-	-	-	X
INPUT_CHAR	-	-	-	-	-	-	-	-	X
PRINT_CHAR	-	-	-	-	-	-	-	-	X
READ_VAR	X	-	X	X	-	-	-	-	-
SEND_EMAIL	-	-	-	-	-	-	-	-	X
WRITE_VAR	X	-	X	X	-	-	-	-	-
X Yes - No									

Protocols supported by the messaging service functions in a Modicon M580 platform:

Function	TCP/IP	ETHWAY	CANopen	Modbus serial	Modbus Plus	Fipway	Uni- Telway	Fipio	Character mode
DATA_EXCH	X	-	-	X	-	-	-	-	-
GET_TS_EVENT_M	X	-	-	-	-	-	-	-	-
INPUT_BYTE	-	-	-	-	-	-	-	-	X
INPUT_CHAR	-	-	-	-	-	-	-	-	X
PRINT_CHAR	-	-	-	-	-	-	-	-	X
READ_PARAM_MX	X	-	-	-	-	-	-	-	-
READ_STS_MX	X	-	-	-	-	-	-	-	-
READ_VAR	X	-	-	X	-	-	-	-	-
RESTORE_PARAM_MX	X	-	-	-	-	-	-	-	-
SAVE_PARAM_MX	X	-	-	-	-	-	-	-	-
SEND_EMAIL	X	-	-	-	-	-	-	-	-
WRITE_CMD_MX	X	-	-	-	-	-	-	-	-
WRITE_PARAM_MX	X	-	-	-	-	-	-	-	-
WRITE_VAR	X	-	-	X	-	-	-	-	-
X Yes - No									

Protocols supported by the messaging service functions in a Modicon Quantum platform:

Function	TCP/IP	ETHWAY	CANopen	Modbus serial	Modbus Plus	Fipway	Uni-Telway	Fipio	Character mode
CREAD_REG	X	-	-	-	X	-	-	-	-
CWRITE_REG	X	-	-	-	X	-	-	-	-
EXCH_QX	X	-	-	X	-	-	-	-	-
INPUT_CHAR_QX	-	-	-	-	-	-	-	-	X
MBP_MSTR	X	-	-	-	X	-	-	-	-
PRINT_CHAR_QX	-	-	-	-	-	-	-	-	X
READ_REG	X	-	-	-	X	-	-	-	-
READ_REG_QX	-	-	-	X	-	-	-	-	-
READ_STS_QX	X	-	-	-	-	-	-	-	-
WRITE_CMD_QX	X	-	-	-	-	-	-	-	-
WRITE_REG	X	-	-	-	X	-	-	-	-
WRITE_REG_QX	-	-	-	X	-	-	-	-	-
XXMIT	-	-	-	X	-	-	-	-	X
X Yes - No									

Protocols supported by the messaging service functions in a Modicon Momentum platform:

Function	TCP/IP	ETHWAY	CANopen	Modbus serial	Modbus Plus	Fipway	Uni-Telway	Fipio	Character mode
MBP_MSTR	X	-	-	-	X	-	-	-	-
XMIT	-	-	-	X	-	-	-	-	X
XXMIT	-	-	-	X	-	-	-	-	X
X Yes - No									

Protocols supported by the messaging service functions in a Modicon Premium platform:

Function	TCP/IP	ETHWAY	CANopen	Modbus serial	Modbus Plus	Fipway	Uni-Telway	Fipio	Character mode
DATA_EXCH	(1)	X	-	-	-	X	X	-	-
INPUT_BYTE	-	-	-	-	-	-	-	-	X
INPUT_CHAR	X	X	-	-	-	X	-	-	X
OUT_IN_CHAR	X	X	-	-	-	X	-	-	X
OUT_IN_MBUS	-	-	-	X	-	-	-	-	-
PRINT_CHAR	X	X	-	-	-	X	-	-	X
RCV_TLG	-	-	-	-	-	X	-	-	-
READ_ASYN	X	-	-	-	-	-	-	-	-
READ_GDATA	-	-	-	-	X	-	-	-	-
READ_VAR	X	X	-	X	X	X	X	X	-
SEND_REQ	X	X	X	X	X	X	X	X	-
SEND_TLG	-	-	-	-	-	X	-	-	-
UNITE_SERVER	-	-	-	X	-	-	-	-	-
WRITE_ASYN	X	-	-	-	-	-	-	-	-
WRITE_GDATA	-	-	-	-	X	-	-	-	-
WRITE_VAR	X	X	-	X	X	X	X	X	-

X Yes

- No

(1) Exchanges between applications and UNI-TE requests are available but Modbus requests coding is not available with an ETY Premium module.

Chapter 3

Interoperability

List of Modbus Function Codes

At a Glance

Quantum, Premium and M340 PLCs have communication server kernels that accept the common Modbus function codes. These are listed in the table on this page.

As servers, Quantum, Premium and M340 PLCs recognize all **Class 0** and **Class 1** Modbus function codes, as stipulated in the Modbus specifications available at <http://www.Modbus.org>. Their server kernel also includes the function code 23 for reading/writing of consecutive variables.

For the list of Modbus function codes recognized by Quantum PLCs, please refer to the specific Quantum documentation.

For the list of function codes recognized by Premium PLCs, please refer to the specific Premium (see *Premium and Atrium using Unity Pro, Asynchronous Serial Link, User Manual*) documentation. In addition to this, Premium PLCs recognize certain UNI-TE (see *Unity Pro, Communication, Block Library*) requests.

List of Modbus Requests Recognized When Connected as a Server

The following table lists the function codes and the address of the Modbus function codes, recognized by Premium, Quantum and M340 platforms.

Function code	Quantum memory address	M340 and Premium memory address	Meaning
1	16#0XXX	%M	Read output bits, refer to note below.
2	16#1XXX	%M	Read input bits
3	16#4XXX	%MW	Read consecutive integer values (until 125 registers for Premium/Atrium PLCs)
4	16#3XXX	%MW	Read consecutive input integer values (until 124 registers for Premium/Atrium PLCs)
5	16#0XXX	%M	Write single output bit
6	16#4XXX	%MW	Write single integer value
15 ¹	16#0XXX	%M	Write n output bits
16 ¹	16#4XXX	%MW	Write consecutive integer values
23 ²	16#4XXX	%MW	Read/write consecutive integer values ³

¹When using the SEND_REQ communication function to send these codes, the maximum size that can be used is 121 words (1936 bits).

²This function is neither supported nor transmitted by Premium TSX SCP 111, TSX SCP 114 and TSX SCP 1114 communication cards nor by TSX SCY 116 01 and TSX SCY 21601 communication modules.

³On the Premium platform, the Read is done before the Write.

NOTE:

The READ_VAR communication function can read, on any remote devices, up to:

- 1008 consecutive bits for Premium CPUs.
- 2000 consecutive bits for M340 CPUs.

NOTE: To be able to read more than these limitations, the SEND_REQ communication function must be used.

Use of Modbus Function Codes as a Client on Premium and M340

The table below lists the Modbus function codes and their use as a client on Premium, Quantum and M340 PLCs.

Function code	Quantum memory address	M340 and Premium memory address	Modbus request	Communication function
1	16#0XXX	%M	Read output bits	READ_VAR
2	-	%I	Read input bits, see 1)	READ_VAR
3	16#4XXX	%MW	Read consecutive integer values (until 125 registers for Premium/Atrium PLCs)	READ_VAR
4	-	%IW	Read consecutive input integer values (until 124 registers for Premium/Atrium PLCs), see 1)	READ_VAR SEND_RER for Premium/Atrium PLCs
15	16#0XXX	%M	Write n output bits	WRITE_VAR
16	16#4XXX	%MW	Write consecutive integer values	WRITE_VAR

1) The addresses %I and %IW cannot be used when creating a communication function of type READ_VAR with the function input assistant.

The way in which to use function codes with communication functions is described in the Modbus manual (see *Premium and Atrium using Unity Pro, Asynchronous Serial Link, User Manual*).

NOTE: Interoperability with Windows applications is provided by access to the PLC variables using OFS software.

WARNING

UNEXPECTED APPLICATION BEHAVIOR - DATA EXCHANGE COMPATIBILITY

Data structure alignments are not the same for Premium/Quantum and M340 PLCs so verify that the data exchanged are compatible.

See the page DDT: Mapping rules (see *Unity Pro, Program Languages and Structure, Reference Manual*) for more information.

Failure to follow these instructions can result in death, serious injury, or equipment damage.

Chapter 4

Communication Architectures

Subject of this Chapter

This chapter gives an overview of the different communication architectures.

What Is in This Chapter?

This chapter contains the following topics:

Topic	Page
Global Architecture	42
Network Architectures	46
Fieldbus	50

Global Architecture

At a Glance

Schneider has a communications strategy based on open standards (core of the range) such as:

- Ethernet Modbus TCP/IP
- CANopen
- AS-Interface
- Modbus Link Series

This has not always been the case and there are a significant number of installed bases on networks or proprietary buses such as Modbus Plus, Fipway, Ethway, X-Way on TCP/IP, Fipio, Symax and Uni-telway.

Schneider offers a connectivity range for the main standards available on the market through its Profibus, Interbus and TCPopen ranges.

The possible and recommended communication architectures are presented in the following pages, according to the type of PLC used:

- At level 2: Inter-PLC network ([see page 46](#)),
- At level 1: Field Bus ([see page 50](#)).

The communication solutions for existing installations, from the Telemecanique or Modicon ranges, are then presented.

Global Architecture

The following diagram shows a global communication architecture with an AS-i bus:

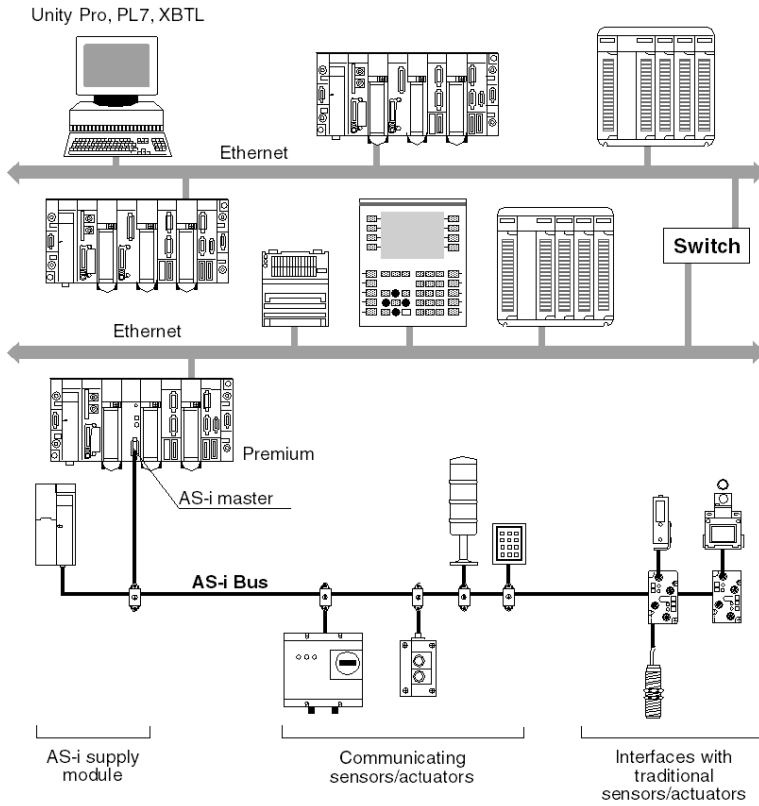

The following diagram shows a global communication architecture with a Modbus and Uni-Telway bus:

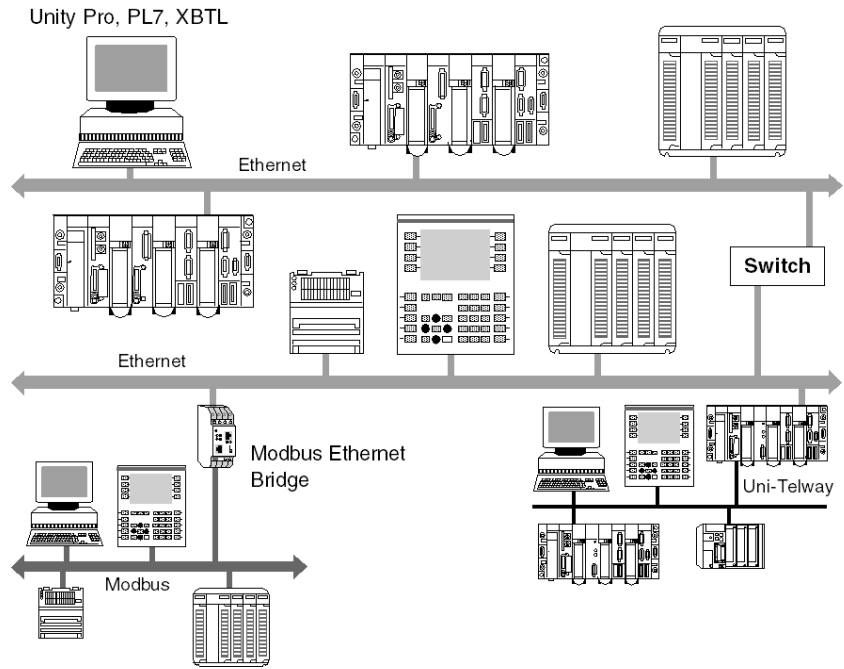

The following diagram shows a global communication architecture with a Modbus and Fipio bus:

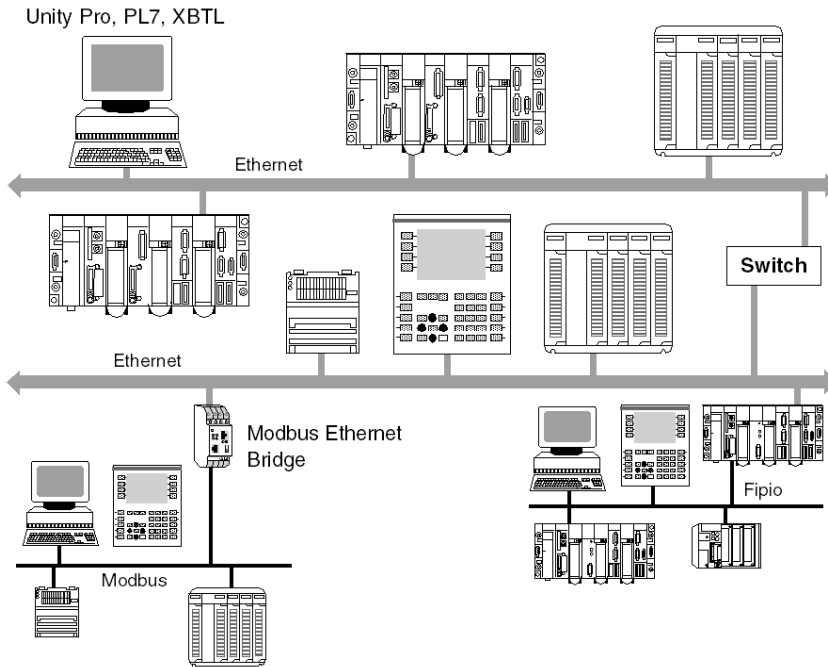

NOTE: Depending on the type of network used, the interconnection is made either directly via a PLC which routes the information (Ethernet/Uni-Telway), or via an additional device such as a bridge (Ethernet/Modbus) or switch (Ethernet/Ethernet).

NOTE: Technically, sophisticated solutions using Ethernet, Modbus Plus, Fipway, Fipio, Modbus, Uni-Telway etc. in a single architecture are possible. However, to facilitate maintenance, user training and to reduce operating costs, it is recommended that you aim for maximum homogeneity between the types of networks and buses used. In the following architecture examples, we give an overview of the most suitable solutions depending on the devices connected.

Network Architectures

At a Glance

Various network architectures are available. The Schneider product range enables you to create standard Ethernet mono-networks as well as transparent multi-network architectures (Ethernet/Fipway/Modbus Plus). The following examples of network architectures show the various optimal solutions provided by Schneider products.

NOTE: The selection of an architecture with the Modbus Plus network or Fipway network is strongly linked to the use of Quantum or Premium devices:

- Modbus Plus for Quantum and Premium PLCs,
- Fipway for Premium PLCs.

NOTE: In the following illustrations, the arrows show the different communication possibilities.

NOTE: An attempt has been made to show all the available scenarios.

NOTE: The types of communication shown in the homogeneous Ethernet networks are also possible when these networks are extended using Modbus Plus or Fipway segments.

Mono-Network Ethernet Architecture

The diagram below shows an Ethernet mono-network:

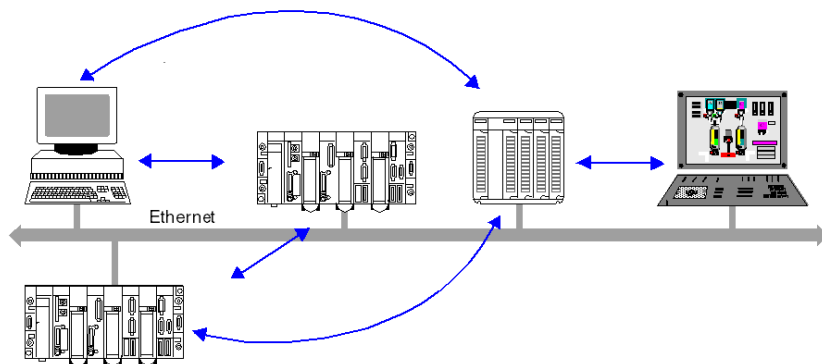

NOTE: All inter-device exchanges are possible.

Multi-Network Ethernet Architecture

The diagram below shows an Ethernet multi-network:

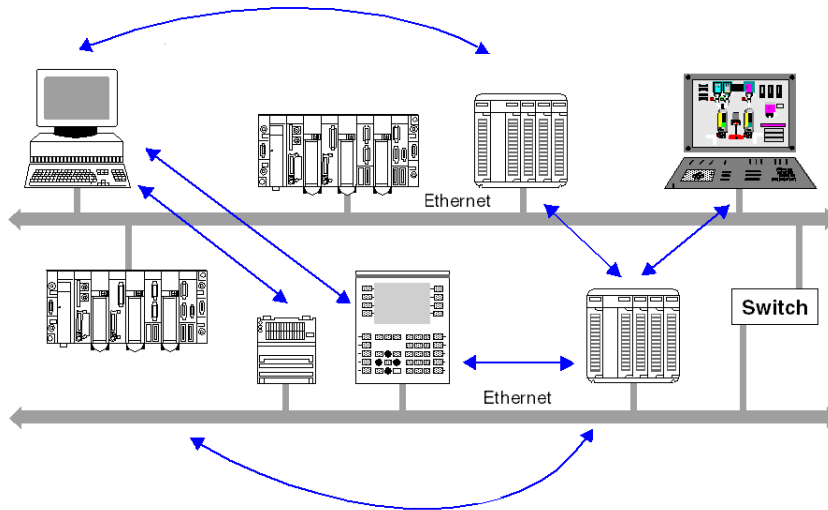

NOTE: All inter-device exchanges are possible.

Multi-Network Ethernet/Modbus Architecture

The diagram below shows an Ethernet/Modbus multi-network:

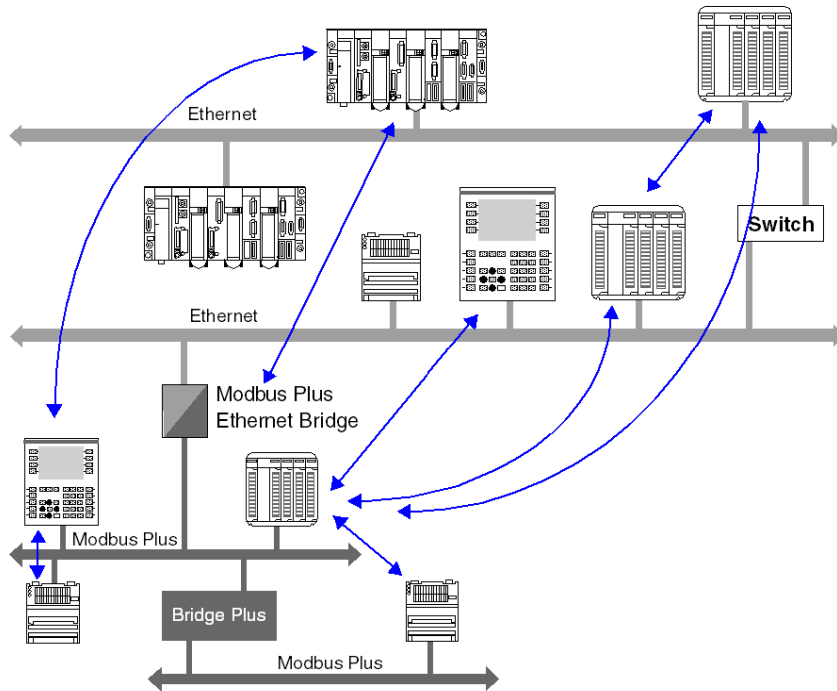

NOTE: Access is possible from devices on the Modbus Plus network across Ethernet/Modbus Plus bridges. In contrast, the devices on the second Modbus Plus network cannot be accessed by an Ethernet device via the Bridge Plus.

Multi-Network Ethernet/Fipway Architecture

The diagram below shows an Ethernet/Fipway multi-network:

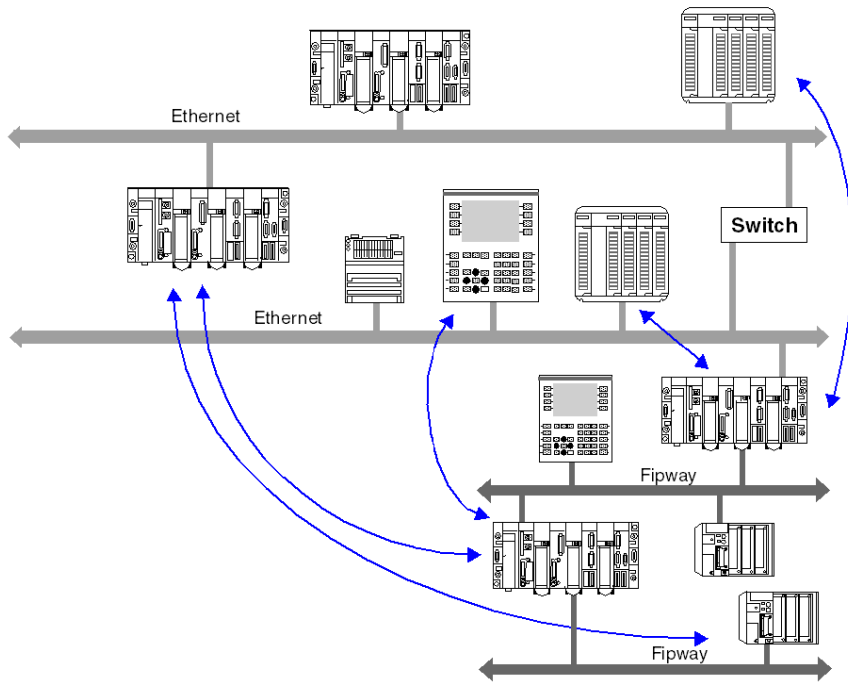

NOTE: All inter-device exchanges are possible.

Fieldbus

At a Glance

The CPU uses many types of fieldbus: Ethernet, CANopen, Modbus, Modbus Plus, AS-i, Fipway, Uni-Telway, Fipio, INTERBUS, and PROFIBUS.

Field buses addressed by each platform:

Fieldbus	Platform				
	M340	M580	Quantum	Momentum	Premium
Ethernet	X*, O	X, O	X*, O	X*	X*, O
CANopen	X*	–	–	O	O
Modbus	X, O	O	X	X	O
Modbus Plus	O*	O*	X	O	O
AS-i	O	O	O	–	O
Fipway	–	–	–	–	O
Uni-Telway	–	–	–	–	X, O
Fipio	–	–	–	O	X*
INTERBUS	–	–	O	O	O
PROFIBUS	O*	O*	O, O*	O	O, O*

X Embedded in the CPU.
X* Embedded in some CPUs.
O Available through extension modules (inserted in the CPU or added in a rack).
O* Communication is performed using a gateway connected to the Ethernet distributed network addressed by the CPU or by an Ethernet module.
– Not available.

Chapter 5

X-Way Message Routing

Subject of this Chapter

This chapter describes the principles of X-Way message routing on X-Way multi-network architectures.

What Is in This Chapter?

This chapter contains the following topics:

Topic	Page
General	52
Features	53
Main Address	55
Multi-Module Station Addresses	56
Messaging	57

General

Introduction

A multi-network architecture consists of several networks. Two levels of architecture are distinguished:

- Multi-module architectures, in which there are several networks but no communication between these different segments is provided by the communication system.
- Multi-network architectures, composed of several network segments interconnected by bridge stations. Communication transparency is then provided in the equipment group present in this type of architecture.

This chapter describes how to set up the bridge function in a Premium PLC station, as well as the use of communication services in a multi-network architecture. The multi-network architecture complies with X-Way communication standards.

To set up stations on different networks, refer to the documentation corresponding to the module used.

NOTE: X-Way communication is not available for Modicon M340 PLCs.

Features

At a Glance

An X-Way PLC architecture is comprised of various network levels that interconnect via intermediate stations.

In a multi-network architecture, a single logic link must exist between two terminal stations.

Example

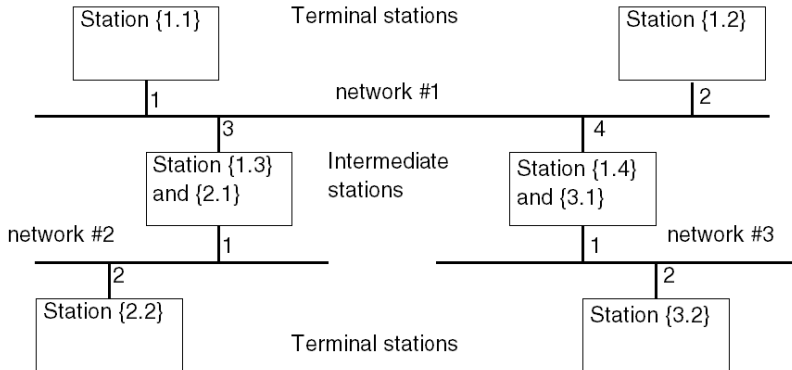

Terminal Stations

A terminal station is addressed by the {network address . station address} pairing.

Terminal stations receive the messages intended for their network address, as well as the general broadcast messages, and send to their network connection all the messages intended for a remote station.

Intermediate Stations

An intermediate station has as many network addresses as it has connection points to different networks. One of its addresses is considered to be the main address and has the role of guaranteeing access to all the communication entities of a routing station.

Intermediate stations are classified in two categories:

- Multicoupler stations
- Bridge stations

Multicoupler Stations

These provide management of various network couplers and guarantee all the mono-network services on the various network segments (common words, telegrams, messaging). They do not offer routing between the various network connections.

Bridge Stations

These provide the same functions as the multi-coupler stations and also guarantee transparency of communication between the various network connections.

Main Address

Introduction

A station configured in bridge mode has as many addresses as it does network connection points. The network address that corresponds to the network module with the lowest module address (module the farthest to the left in the station rack) is regarded as the main address of the station. Using the main address of a station guarantees access to a bridge station.

Rule

A bridge station must always be accessed by its main address.

Addressing Example

The example shows the communication between stations connected on the Fipway networks.

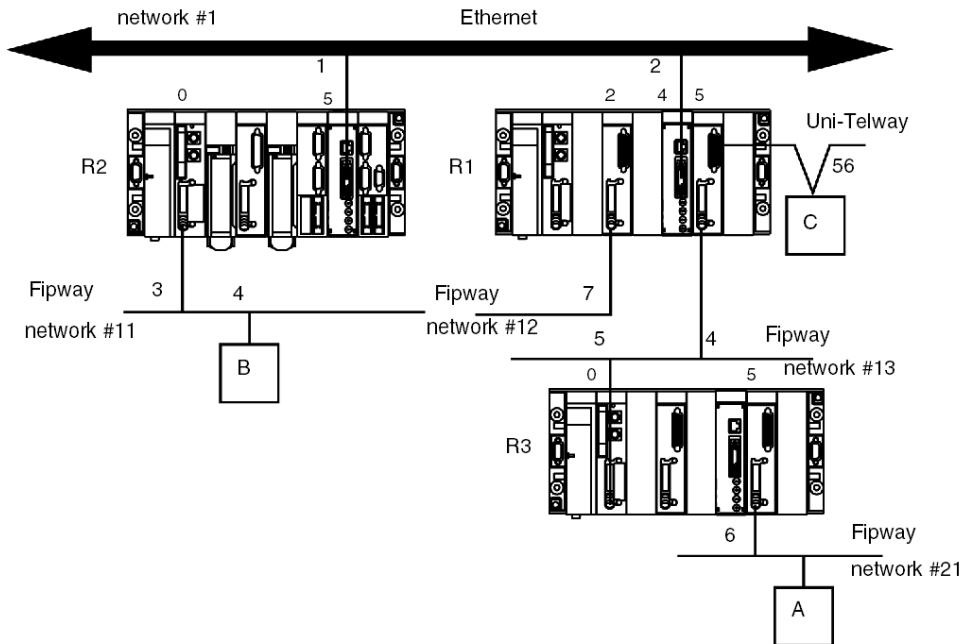

- For a communication from station A to station R2, the main address of station R2 is {11.3}.
- For a communication from station A to station R1, the main address of station R1 is {12.7}.
- For a communication from station A to station R3, the main address of station R3 is {13.5}.
- For a communication from station A to station C, the address of station C is {12.7}5.0.56.

Multi-Module Station Addresses

Introduction

A station configured in multi-module mode has as many addresses as it does network connection points.

There is no main address for the station. It will be addressed according to the network that communicates with it.

Rule

A multi-module station must always be accessed via the network address that corresponds to the network module enabling entry to the station.

Example

In the following example, station R1 does not have the bridge function between its modules 2, 4 and 5.

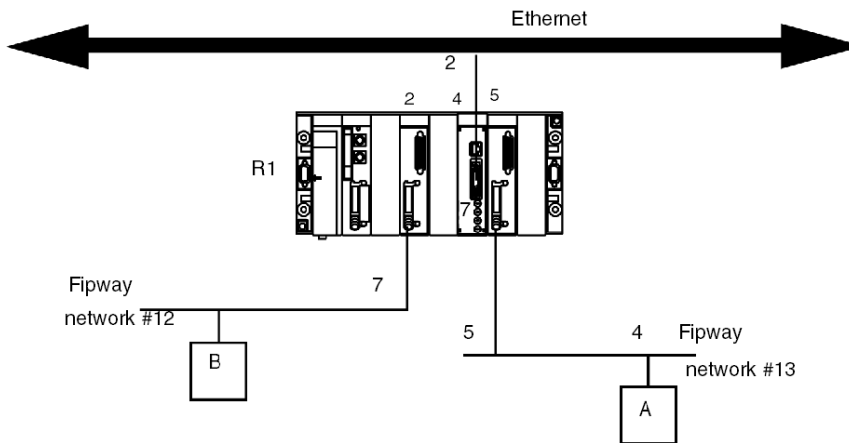

- For a communication from station A to station R1, the address is {13.5}SYS.
- For a communication from station B to station R1, the address is {12.7}SYS.

Messaging

With Multi-Coupler Stations

Messages intended for a network are sent to the coupler connected to the destination network. The configuration phase allows the destination coupler to be determined.

Specific case

Messages intended for a network with an unknown address are sent to the network with the main address of the station, along with messages whose network number is 0.

Example:

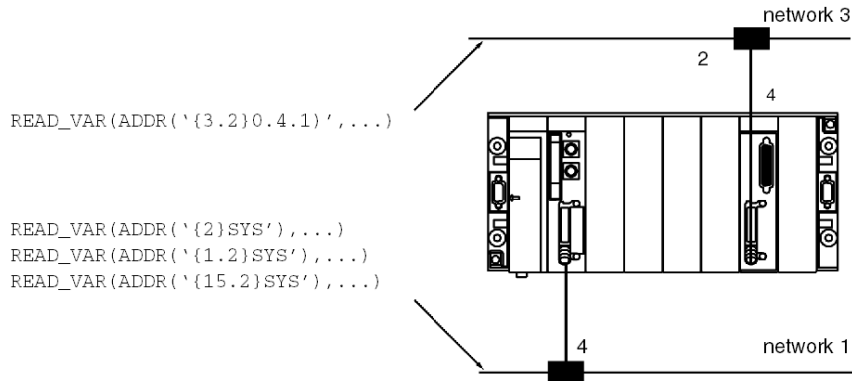

All messages intended for network 3 are sent to the coupler with module address 4, and those whose destination network is 1 to the network link integrated into the processor.

All messages whose network number address is different from 1 or 3 are sent to the processor that manages the main network.

In a multi-coupler architecture, communication is limited to a single network level.

With Bridge Stations

Messages intended for a network are sent to the coupler that has access to this network. The configuration phase allows determination of the accessible networks for each coupler of the station.

Specific case

Messages whose network number is 0 are sent to the network with the main address of the station.

Part II

Addressing

Subject of this Part

This part describes the different addressing solutions for devices on a communication bus or network.

What Is in This Part?

This part contains the following chapters:

Chapter	Chapter Name	Page
6	General Points Concerning Addressing	61
7	IP Addressing	63
8	Modbus Plus Addressing	67
9	X-Way Addressing	71
10	Modicon M340 PLCs Addressing	85
11	General points concerning bridging	99

Chapter 6

General Points Concerning Addressing

General

At a Glance

Within a communication architecture, each device must be identified by an address. This address is specific to each device, and enables the device initiating communication to determine the destination precisely. Similarly, for the configuration of services such as Global Data on Ethernet, the Peer Cop service on Modbus Plus or common words and shared tables on Fipway, these addresses make it possible to identify the stations that own different shared information.

Schneider products support 4 types of addressing depending on the type of device, network or bus used:

- IP addressing (*see page 63*),
- Modbus Plus addressing (*see page 67*),
- X-Way addressing (*see page 71*),
- Modicon M340 PLCs addressing (*see page 85*)

Chapter 7

IP Addressing

Note on IP Addressing

IP Address

On a TCP/IP Ethernet network, each device must have a **unique IP address**. This address is made up of two identifiers, one of which identifies the network, while the other identifies the connected machine.

The uniqueness of the addresses is managed as follows:

- When the network environment is of open type, the uniqueness of the address is guaranteed by the attribution of a network identifier by the relevant authority in the country where the network is located,
- If the type of environment is closed, the uniqueness of the address is managed by the company's network manager.

An IP address is defined as 32 bits. It consists of 4 numbers, one for each byte of the address.

NOTE: Standardized and made common largely thanks to the Internet, IP addressing is described in detail in RFCs (Request For Comment) 1340 and 791 which stipulate the Internet standards as well as in computing manuals describing networks. You can refer to these sources for further information.

Example

Depending on the size of the network, three classes of address can be used:

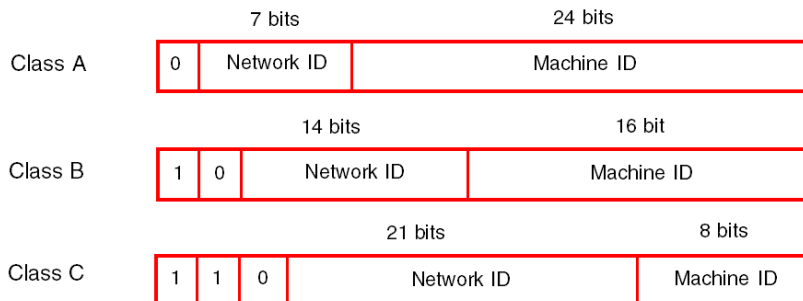

Spaces reserved for the different classes of IP addresses:

Class	Range
A	0.0.0.0 to 127.255.255.255
B	128.0.0.0 to 191.255.255.255
C	192.0.0.0 to 223.255.255.255

- Class A addresses are intended for large-scale networks which have a large number of connected sites.
- Class B addresses are intended for medium-scale networks which have fewer connected sites.
- Class C addresses are intended for small-scale networks which have a small number of connected sites.

Sub-Addressing and Sub-Network Mask

An IP address is composed of two identifiers, one of which identifies the network while the other identifies the connected machine. In reality, the machine identifier can also hold a sub-network identifier.

In an open environment, having received a network identifier from the relevant authority, the local system administrator has the possibility of managing many networks. This means that local networks can be installed without having any effect on the external world, which still sees just one network designated by the network identifier.

The sub-network mask makes it possible to see the number of bits attributed respectively to the network identifier and to the sub-network identifier (bits at 1), and then to the machine identifier (bits at 0).

Example

Example: 140.186.90.3

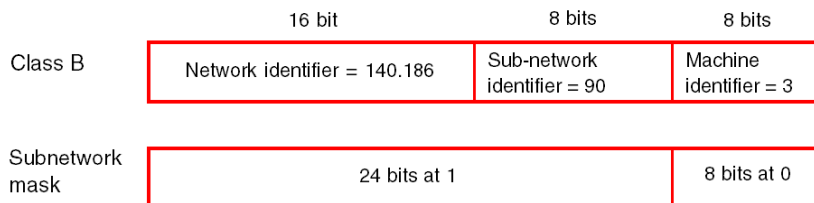

The segmentation allows for 254 possible sub-networks with 254 sub-network machines.

The value of the sub-network mask should be chosen so that it is consistent with the IP address class.

The sub-network mask will have the following value:

- for a class A address: 255.xxx.xxx.xxx,
- for a class B address: 255.255.xxx.xxx,
- for a class C address: 255.255.255.xxx,

xxx is an arbitrary value which can be chosen by the user.

Gateway

The term Gateway is used in this manual in the sense of "router". If the target machine is not connected to the local network, the message will be sent to the "default gateway" connected to the local network, which will guarantee routing to another gateway or towards its final destination.

Chapter 8

Modbus Plus Addressing

Addressing for a Modbus Plus Communication Entity

At a Glance

Modbus Plus addressing makes it possible to identify a device on a Modbus Plus network.

The Modbus Plus addressing system is based on the access path that needs to be followed to reach the destination device. This path is determined by the Modbus Plus routers, also referred to as Bridges Plus. So when a device has to communicate with another device, it is necessary to determine the path taken by the data to be communicated.

Principle

A Modbus Plus network segment may have up to 64 addressable devices. Each device has a unique address between 1 and 64.

Several segments may be linked by Bridges Plus.

The routing path is determined by the 5 bytes that indicate in succession the addresses of the devices that need to be crossed before arriving at the destination.

The routing system makes it possible to cross a maximum of 3 segments, in other words to allow communication between stations belonging to 5 consecutive segments.

NOTE: When not all of the 5 bytes are necessary (only one Bridge Plus crossed for example), the remaining bytes are set to 0.

Illustration

The following illustration shows a multi-segment Modbus Plus structure. Three characteristic examples are used to explain Modbus Plus addressing:

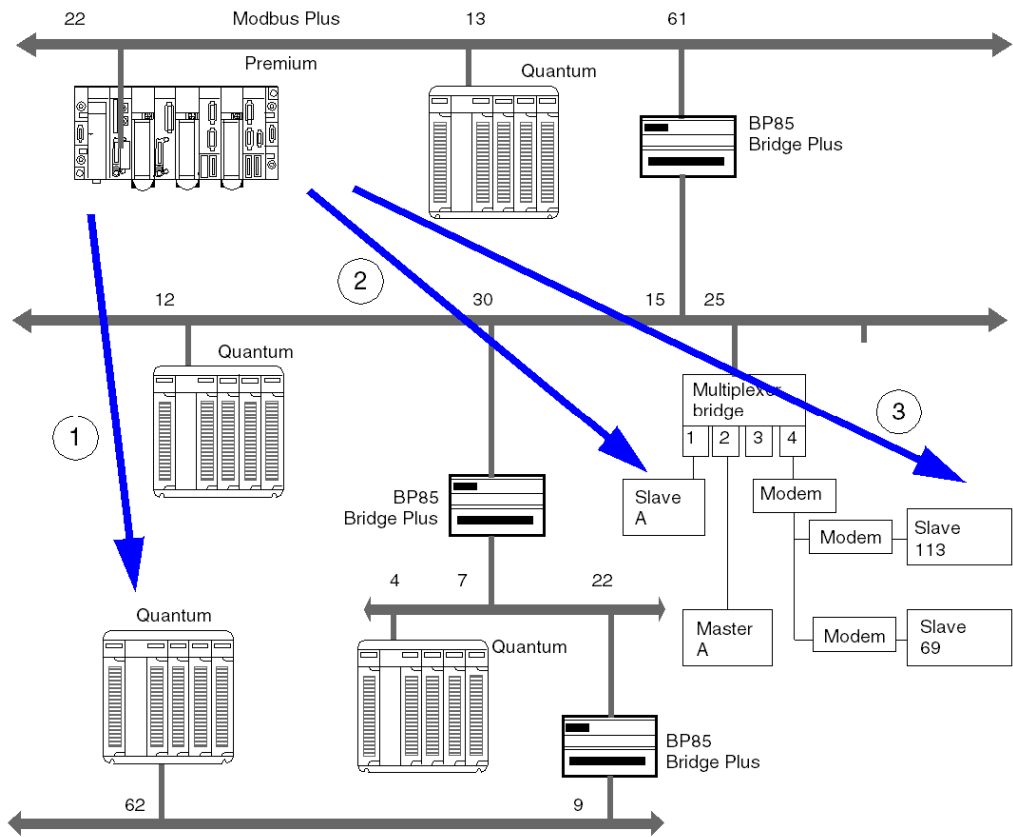

Example 1

The routing path to access the Quantum station is:

61, 30, 22, 62, 0.

NOTE: The final 0 is added so that the address path consists of 5 bytes.

Example 2

The routing path to access slave A is as follows:

61, 25, 1, 0, 0.

NOTE: As slave A is the only slave on port 1, it is sufficient to indicate the port number and complete the path with the zeros to obtain the 5 bytes for the address path.

Example 3

The routing path to access slave 113 is as follows:

61, 25, 4, 113, 0.

NOTE: When several slaves are connected to the same port, it is necessary to indicate the slave number after the port number. Do not forget to complete the address with zeros to obtain 5 bytes.

Chapter 9

X-Way Addressing

Subject of this Chapter

This chapter describes X-Way addressing and indicates its fields of application.

What Is in This Chapter?

This chapter contains the following topics:

Topic	Page
Addressing for a Communication Entity	72
Types of Communication Entities	74
Processor Communication Channel Addressing	76
Addressing for a TSX SCY 21601 Communication Module	78
Examples of Intra-Station Addressing: Uni-Telway Addressing	79
Examples of Intra-Station Addressing: Fipio Addressing	81
Examples of Intra-Station Addressing	82

Addressing for a Communication Entity

At a Glance

X-Way addressing makes it possible to identify a communication entity on a network or a bus, or on a station's bus on a network. Each station is identified by a unique address, which consists of a network number and a station number. The addresses then differ according to the bus:

- Uni-Telway or Modbus bus
- Fipio bus

Within a station, each communication entity is characterized by a topological address (access path) and a type (*see page 74*).

NOTE: An address is expressed in the form of a character string. However, it can only be used in conjunction with the function `ADDR()`, which is why the following notation will be used to describe an address: `ADDR('address string');`

Addressing a Station on a Network

The address of a station on a network takes the form: `ADDR('{n.s}SYS')`

where:

n: network number (**network**)

s: station number (**station**)

SYS: keyword used to stipulate the station server system (*see page 74*)

Addressing a Device on a Uni-Telway or Modbus Bus

The address of a device on a Uni-Telway or Modbus bus depends on the station managing the bus:

- stand-alone station: `ADDR('r.m.c.e')`
- station belonging to a network: `ADDR('{n.s}r.m.c.e')`

where:

n: network number (**network**)

s: station number (**station**)

r: rack number (**rack**)

m: module number (**module**)

c: channel number (**channel**)

e: number of device or slave (**equipment**)

Addressing of a Device on a Fipio Bus

The address of a device on a Fipio bus depends on the station managing the bus:

- stand-alone station: `ADDR ('b.e\SYS')`
- station belonging to a network: `ADDR ('{n.s}\b.e\SYS')`

where:

n: network number (**network**)

s: station number (**station**)

b: bus number (**bus**), for Fipio the bus number is always 2

e: device number (**equipment**)

SYS: keyword used to stipulate the station server system (*see page 74*)

Example

The figure below describes the address of the station located in the gray rectangle. The example here shows slave 2 on channel 1 of the module in rack 0 (base rack), slot 1, on network 20, station 3:

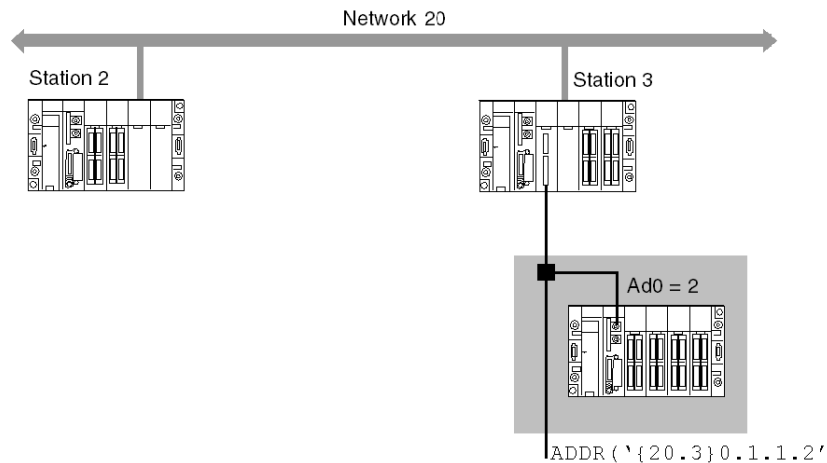

Types of Communication Entities

At a Glance

There are different types of communication entities. To characterize them, the following keywords have been created: `SYS`, `APP`, and `APP.num`. Another keyword, `ALL`, makes it possible to send general broadcast messages.

These exchanges are performed by the communication functions described in the **Communication EF library**.

It is possible to class addresses into three types:

- local addresses
- remote addresses
- broadcast addresses

Keywords

The keywords are as follows:

- `SYS` gives access to the Uni-te server of a processor, channel, communication module, etc.
- `APP` gives access to a station's PL7 or Unity Pro application.
- `ALL` is defined to describe a broadcast. For a TSX SCY 11601 module, the keyword is `0`. It may replace one of the elements of a topological address. The broadcast level is determined according to the location of the keywords `ALL` or `0` in the address:
 - when alongside the network number, the broadcast is sent to all stations on the selected network (e.g.: the address `ADDR (' { 2 . ALL } ')` represents all stations on network 2),
 - when alongside the station number, the broadcast is sent to all the entities connected to the intra-station communication channels (e.g.: the address `ADDR (' { 2 . 4 } ALL ')` represents all the communication entities of station 4 on network 2).

NOTE: For the sender application to communicate with the text function block of a TSX series 7 PLC's PL7-2 or PL7-3 application, the keyword must be `APP.num`, where `num` corresponds to the destination text function block number for the exchange.

Local Addresses

Local addresses contain topological addresses and the addresses of slaves on a bus.

Destination	Local address
Micro/Premium Uni-TE server	SYS
PL7 or Unity Pro application	APP
PL7-3 application	APP.text block number
Uni-Telway slave	module.channel.slave number
Modbus slave	module.channel.slave number
Link in character mode	module.channel.SYS
Module server	module.SYS
Sub-module or channel server	module.channel.SYS
Fipio device server	\bus number.connection point\SYS

Remote Addresses

Remote addresses correspond to the addresses of devices connected to a network.

Destination	Remote address
Destination on remote network	{network.station}local address
Destination on local network	{station}local address

Broadcast Addresses

Broadcast addresses depend on the destination devices.

Destination	Broadcast address
Broadcast to all stations	{network.ALL}local address
Broadcast to all local addresses	{network.station}ALL
Broadcast to all modules	ALL.SYS
Broadcast to all Uni-Telway or Modbus slaves	module.channel.ALL
Broadcast to all Modbus slaves with a TSX SCY 11601 module	module.channel.0

NOTE: For Modbus equipments the report code of Broadcast function for a correct operation is 1.

Processor Communication Channel Addressing

At a Glance

Following are examples of the different types of addressing for a processor's communication channels.

The examples are based on a Premium type processor.

The modules have a topological address that is a function of the module's position in the rack.

Depending on the desired configuration, there may be either a single or double power supply, which occupies 1 or 2 slots in the rack respectively. As a result, the first slot the processor uses is either 0 or 1.

With a Single Power Supply

The power supply occupies one slot. The processor's communication channels can then have the following addresses:

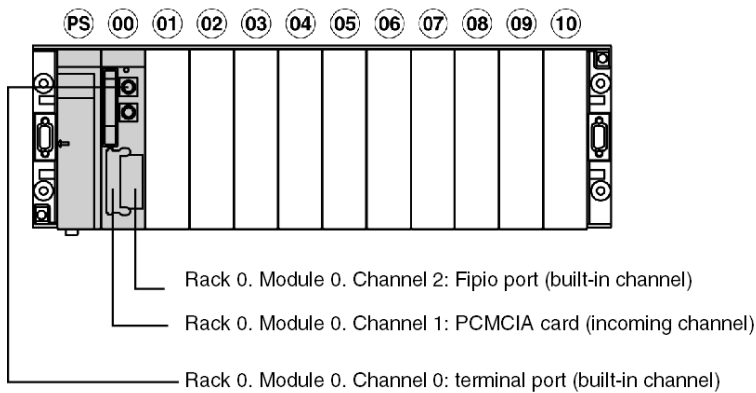

With a Double Power Supply

The power supply occupies two slots. The processor's communication channels can then have the following addresses:

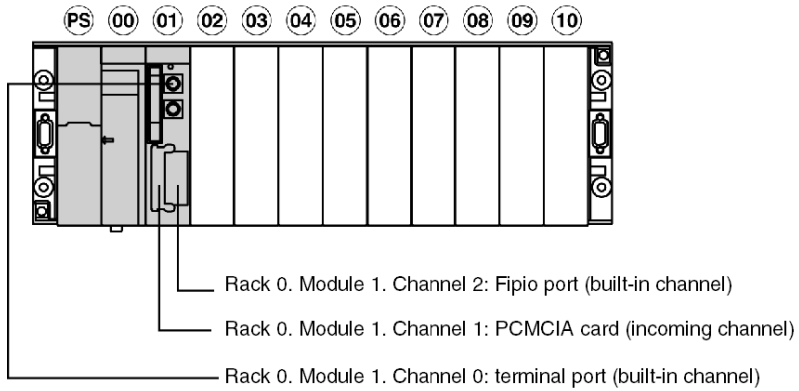

Addressing for a TSX SCY 21601 Communication Module

At a Glance

Following are examples of the different types of addressing for TSX SCY 21601 communication modules.

The examples are based on a Premium type processor.

NOTE: These types of communication module are limited according to processor. Please refer to the installation manual to determine the number of expert communication channels.

Examples

The module's communication channels can have the following addresses:

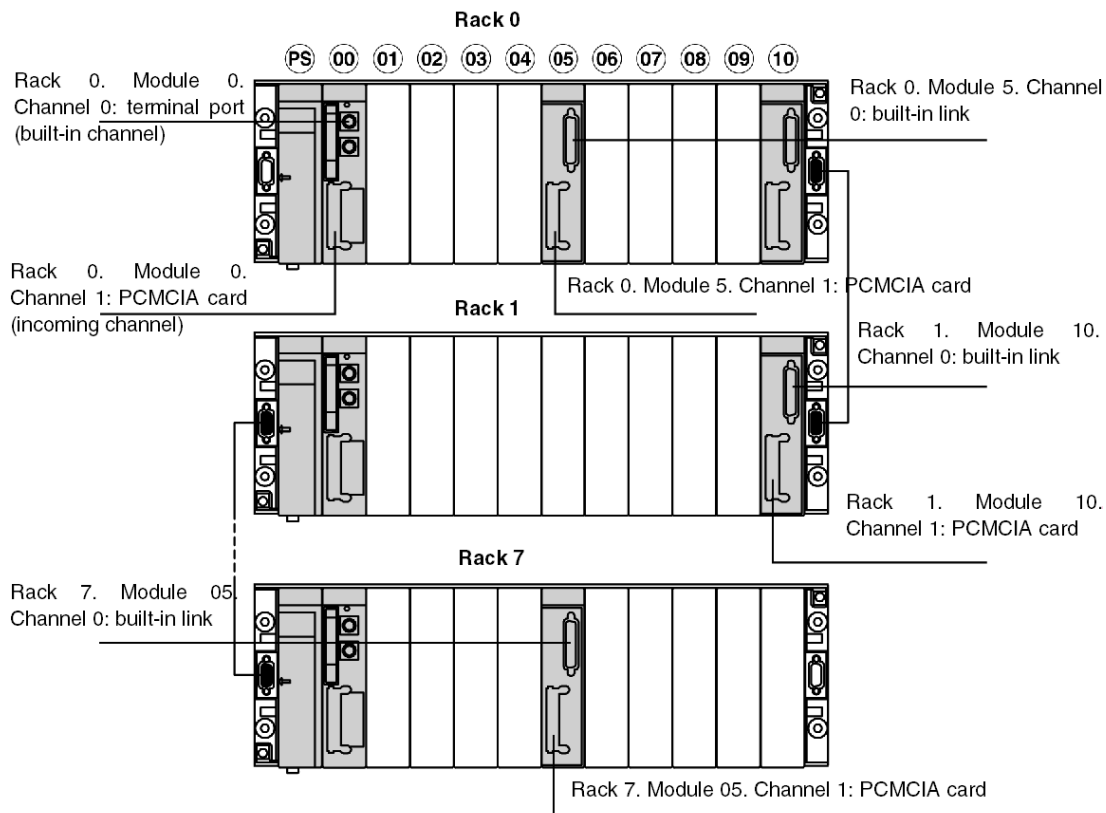

Examples of Intra-Station Addressing: Uni-Telway Addressing

At a Glance

With this type of addressing, a master station can access different slaves connected to a bus.

In the following examples, the slaves are connected to the master station (with a Premium processor) via a Uni-Telway bus.

Addressing Rules

In this configuration, the addressing values are as follows:

- For the rack address:
 - 0 to 7
- For the module address:
 - 0 to 14
- For the channel address:
 - 0 if connected via the terminal port
 - 0 if connected via a built-in link of a TSX SCY 21601 module
 - 1 if connected via a PCMCIA card
- For the slave:
 - 1 to 98 if the slave is connected to a PCMCIA card or the built-in link of the TSX SCY 21601 module. In this case, the master station can scan up to 98 slaves.
 - 1 to 8 if the slave is connected to the terminal port. In this case the master station can scan up to 8 slaves.

CAUTION

UNEXPECTED BEHAVIOR OF APPLICATION

Do not use wrong address parameters. For instance:

- Do not set an address parameter that does not correspond to the targeted equipment.
- Do not use value greater than 98 in ADDR function (field "e" for the equipment address) when using a TSXSCY21601 or higher than 8 when using a CPU embedded serial port.

Failure to follow these instructions can result in injury or equipment damage.

Connection via Terminal Port

A device with the address Ad0=8 is connected to the terminal port of a Premium.

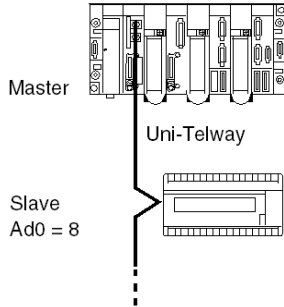

Address settings of slave 8: ADDR ('0.0.0.8')

Connection via TSX SCY 21601 Module

A device with the address Ad0=1 is connected to the built-in link of a TSX SCY 21601 at position 2 in the base rack.

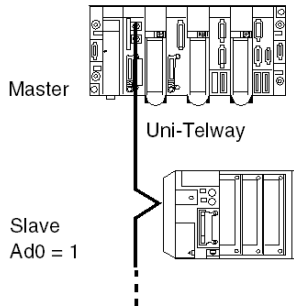

Address settings of slave 1: ADDR ('0.2.0.1')

Examples of Intra-Station Addressing: Fipio Addressing

At a Glance

Exchanges with the bus manager are of variable exchange or message exchange type.

The addressing syntax to access the Unite messaging server is as follows:

\ bus number . connection point \ SYS

Addressing Rules

For Fipio communication, the addressing values are as follows:

- For the bus address: always 2 for a Fipio bus,
- For the connection point: 1 to 127 as it is possible to connect up to 127 devices on the bus.

Examples

In the following example, the bus manager addresses the Premium at connection point 4, or the Magelis at connection point 8.

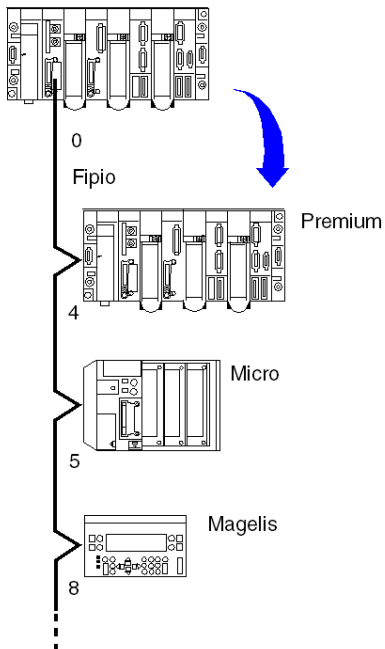

Address settings of device 4: `ADDR ('\2.4\SYS')`

Address settings of device 8: `ADDR ('\2.8\SYS')`

Examples of Intra-Station Addressing

At a Glance

For an intra-station exchange to take place (i.e. an exchange between two stations on the same network or on different networks), the address must also show the destination entity's network number and station number.

Example 1

The multi-network configuration is as follows:

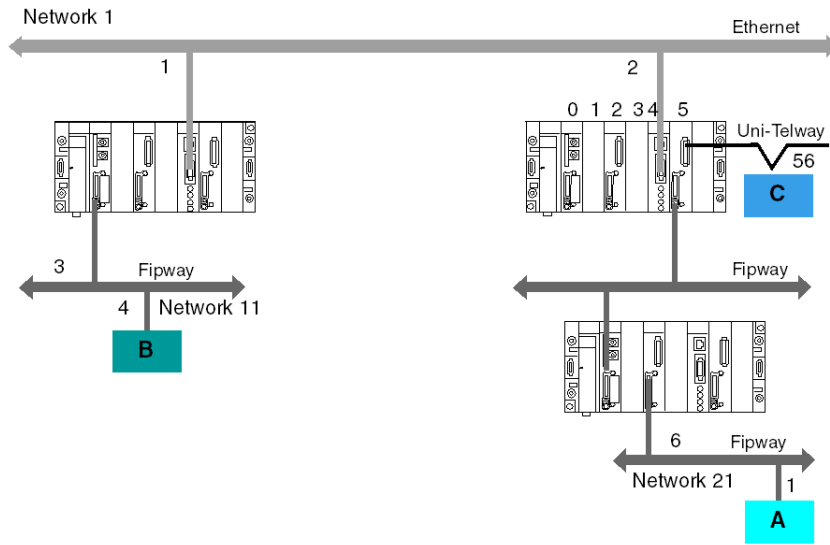

In the first case, station B addresses station A's system:

```
ADDR ('{21.1} SYS')
```

In the second case, station B addresses station C:

```
ADDR ('{1.2}0.5.0.56')
```

Example 2

The example below shows how to access a Magelis system connected to a Fipio bus (connection point 6) and communicate with text block TXT 8 on a model 40 programmable PLC connected to network 2.

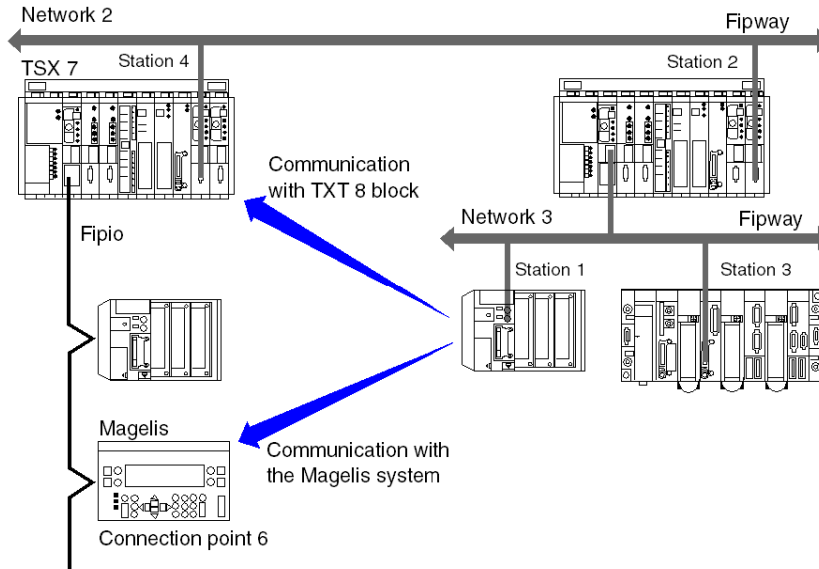

The address of the TXT 8 text block on the TSX 7 PLC station 4 is:

```
ADDR ('{2.4}APP.8')
```

The address of the Magelis system is:

```
ADDR ('{2.4}\2.6\SYS')
```

Chapter 10

Modicon M340 PLCs Addressing

Purpose of this Chapter

This chapter describes Modicon M340 PLCs addressing and indicates its fields of application.

What Is in This Chapter?

This chapter contains the following topics:

Topic	Page
Modicon M340 Types of Communication Entities	86
Modicon M340 Addressing for a Communication Entity	87
Processor Communication Channels Addressing	90
Example of Modicon M340 Ethernet Addressing	92
Example of Modicon M340 CANopen Addressing	93
Examples of Modicon M340 Modbus and Character Mode Addressing	94
Examples of Modicon M340 Communication EFs Addressing	96

Modicon M340 Types of Communication Entities

At a Glance

There are different types of communication entities.

These exchanges are performed by the communication functions described in the Communication EF library.

It is possible to class addresses into 3 types:

- local addresses, identified by `r.m.c.SYS`, or more simply, `r.m.c`,
- remote addresses, to address a device (Modbus, CANopen or Ethernet) directly connected to the channel,
- broadcast addresses, depend on the network. For Modbus communication, broadcast address is obtained with the slave number set to 0. Note that a broadcast address can be used for all networks but requires that the communication channel supports broadcasting. This is not always the case.

SYS Keyword

`SYS` gives access to a local module or a channel server. `SYS` is used for character mode and can be omitted.

Broadcast Addresses

Broadcast addresses depend on the destination devices:

Destination	Broadcast address
Broadcast to all Modbus slaves (the slave number equals 0)	rack.module.channel.0

Modicon M340 Addressing for a Communication Entity

At a Glance

With Modicon M340 PLCs, it is possible to address any Modicon M340 PLC communication channel and any device directly connected to a Modicon M340 PLC communication channel.

Each device is identified by a unique address, which consists of a device number or an IP address. The addresses then differ according to the protocol:

- Ethernet TCP/IP
- Modbus or CANopen
- Character Mode

Within a station, each communication entity is characterized by a topological address (access path) and a target entity.

NOTE: An address is expressed in the form of a character string. However, it can only be used in conjunction with the function `ADDMM`, which is why the following notation will be used to describe an address: `ADDMM('address string')`.

Modicon M340 addressing uses 3 concepts:

- The target entity depends on the communication EF and is chosen implicitly:
 - `MBS` for addressing a Modbus server,
 - `TCP.MBS` for addressing a TCP Modbus server,
 - `SYS` for addressing a channel server on Character mode. `SYS` can be omitted.
- The communication channel is explicit (processor's or module's position and communication channel number) or symbolized with the Netlink name for Ethernet communication.
- The node address depends on the communication protocol:
 - IP address with Ethernet,
 - node address with CANopen,
 - slave address with Modbus.

Addressing a Station on a Ethernet

The address of a station on Ethernet takes the form:

- `ADDM('Netlink{hostAddr}')`
- `ADDM('Netlink{hostAddr}TCP.MBS')`
- `ADDM('Netlink{hostAddr}node')`
- `ADDM('r.m.c{hostAddr}')`
- `ADDM('r.m.c{hostAddr}TCP.MBS')`
- `ADDM('r.m.c{hostAddr}node')`
- `ADDM('{hostAddr}')`
- `ADDM('{hostAddr}TCP.MBS')`
- `ADDM('{hostAddr}node')`

Where:

- Netlink: network name set in the Net Link field of Ethernet channel
- hostAddr: IP address of device
- r: rack number (rack)
- c: channel number (channel)
- node: Modbus or CANopen node behind a gateway (gateway identified with hostAddr)

NOTE: If the netlink name is omitted the system takes the default netlink connection which is the closest link to the processor (usually the processor Ethernet channel).

Addressing of a Device on a CANopen Bus

The address of a device on a CANopen bus takes the form `ADDM('r.m.c.e')`, where:

- r: rack number (rack)
- m: rack module position
- c: channel number (channel) of CANopen port (2)
- e: CANopen slave node (equipment) (range 1 to 127)

Addressing a Device on a Modbus

The address of a device on a Modbus bus takes the form `ADDM('r.m.c.e.MBS')`, where:

- r: rack number (rack)
- m: rack module position
- c: channel number (channel) of Modbus port (0)
- e: Modbus slave number (equipment) (range 1 to 247)

Addressing a Device on Character mode

To send or receive a character string, you can use `ADDM('r.m.c')` or `ADDM('r.m.c.SYS')`, where:

- r: rack number (rack)
- m: rack module position
- c: channel number (channel) of Character mode port (0)
- SYS: keyword used to stipulate the station server system ([see page 86](#)). SYS can be omitted.

Example

The figure below describes the address of the servodrive. The example here shows slave 14 on channel 2 (CANopen) of the module in rack 0, slot 0:

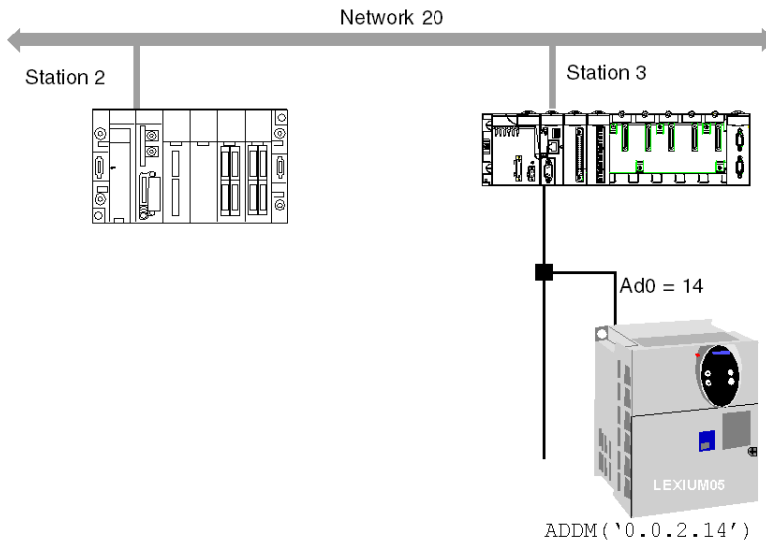

Processor Communication Channels Addressing

At a Glance

Following are examples of the different types of addressing for a processor's communication channels.

The examples are based on a Modicon M340 type processor.

The modules have a topological address that is a function of the module's position in the rack.

The first two slots of the rack (marked PS and 00) are reserved for the rack's power supply module (BMX CPS ••••) and the processor (BMX P34 •••••) respectively.

Available communication channels

The available communication channels vary depending on the processor:

Processor	Integrated Modbus Connection	Integrated CANopen Master Connection	Integrated Ethernet Connection
BMX P34 1000	X	-	-
BMX P34 2000	X	-	-
BMX P34 2010/20102	X	X	-
BMX P34 2020	X	-	X
BMX P34 2030/20302	-	X	X
Key			
X Available			
- Not available			

Processor Communication Channels Addressing

The diagram below shows an example of Modicon M340 configuration including a BMX P34 2010 processor and the addresses of the processor communication channels:

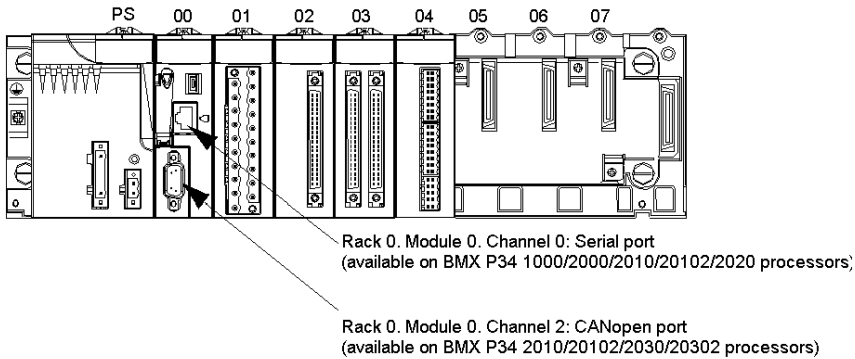

The diagram below shows an example of Modicon M340 configuration including a BMX P34 2030 processor and the addresses of the processor communication channels:

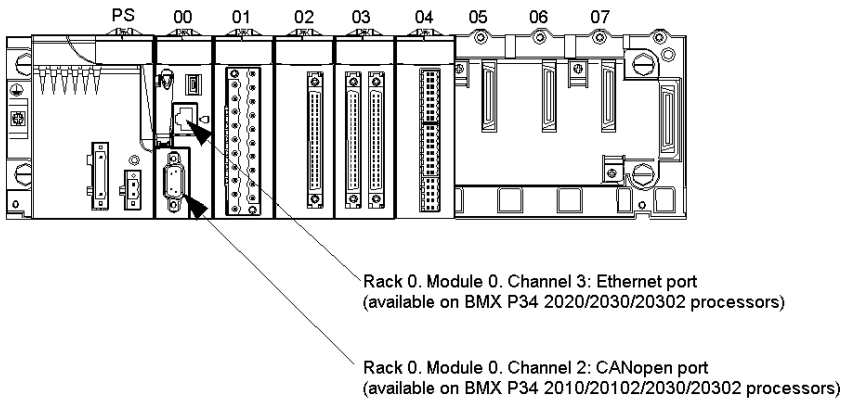

Example of Modicon M340 Ethernet Addressing

At a Glance

With this type of addressing, a station can access different station connected to logical network.

Connection via CPU Ethernet port

A device with the IP address 139.180.204.2 is connected to the Ethernet network. It is the processor Ethernet port configured with Netlink name `Ethernet_1`.

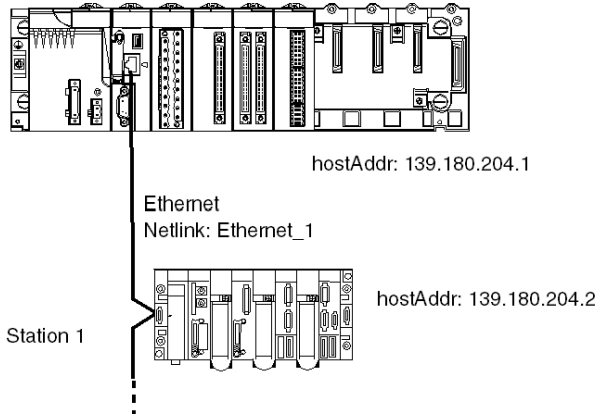

Address settings station 1: `ADDM('0.0.3{139.180.204.2}')`

or Address settings station 1: `ADDM('Ethernet_1{139.180.204.2}')`

Example of Modicon M340 CANopen Addressing

At a Glance

With this type of addressing, a master station can access different slaves connected to CANopen bus.

Addressing Rules

The syntax of CANopen addressing is `ADDM ('r.m.c.node')`. The meaning of the string parameter is as follows:

- r: rack address. The processor's rack address is always 0.
- m: module address. The Modicon M340 processor's slot number in the rack is always 0.
- c: channel address. The Modicon M340 CANopen port is always channel 2.
- node: slave number to which the request is being sent. The range for configured slave numbers is from 1 to 127.

Example

In the following example, the Modicon M340 processor's bus manager addresses the Lexium 05 device at connection point 28:

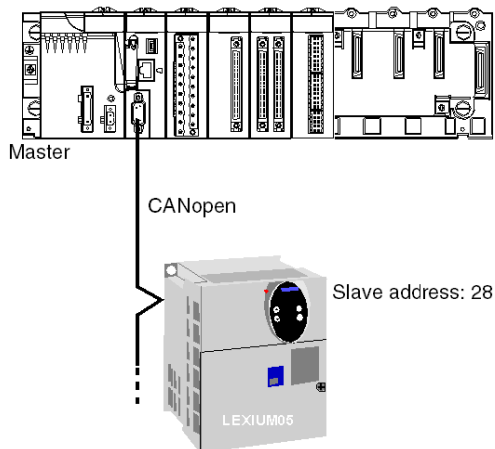

Address settings of slave 28: `ADDM ('0.0.2.28')`.

NOTE: In addition to the address defined by `ADDM`, the `READ_VAR` and `WRITE_VAR` functions use another parameter `NUM`, which must be defined to address the SDO to be read or written.

Examples of Modicon M340 Modbus and Character Mode Addressing

At a Glance

The following examples deal with:

- Modbus addressing
- Character mode addressing.

Modbus Addressing Rules

The syntax of Modbus addressing is `ADDM ('r.m.c.node')`. The meaning of the string parameter is as follows:

- r: rack address. The processor's rack address is always 0.
- m: module address. The Modicon M340 processor's slot number in the rack is always 0.
- c: channel address. The Modicon M340 processor's serial port is always channel 0.
- node: slave number to which the request is being sent. The range for configured slave numbers is from 1 to 247.

NOTE: In a Modbus Slave configuration, an additional address, number 248, is used for a point-to-point serial communication.

Serial Link Using Modbus Protocol

The diagram below shows two Modicon M340 processors connected via a serial link and using Modbus protocol:

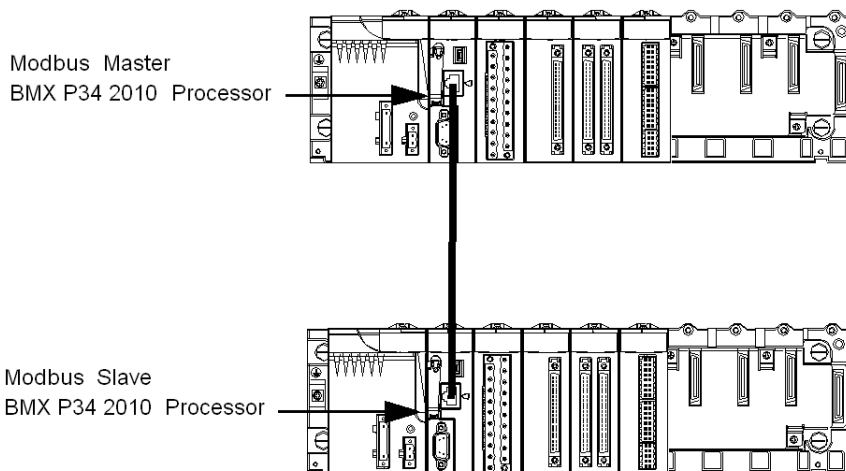

The address settings of the slave processor number 8 are `ADDM ('0.0.0.8')`.

Character Mode Addressing Rules

The syntax of Character mode addressing is `ADDM ('r.m.c')` or `ADDM ('r.m.c.SYS')` (`SYS` can be omitted). The meaning of the string parameter is as follows:

- `r`: rack address of the connected device.
- `m`: module address of the connected device.
- `c`: channel address of the connected device.
- `SYS`: keyword used to stipulate the station server system. `SYS` can be omitted.

Serial Link Using Character Mode Protocol

The diagram below shows a Modicon M340 processor linked to a data entry/display terminal TM8501:

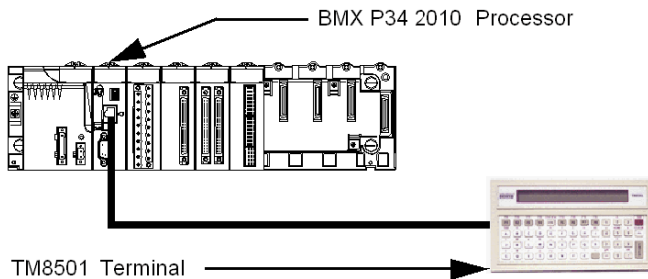

The address settings of the TM8501 terminal are `ADDM ('0.0.0')` or `ADDM ('0.0.0.SYS')`.

Examples of Modicon M340 Communication EFs Addressing

At a Glance

The multi-network addressing available on Modicon M340 PLCs is described below.

Example 1

The first example is a multi-network configuration as follows:

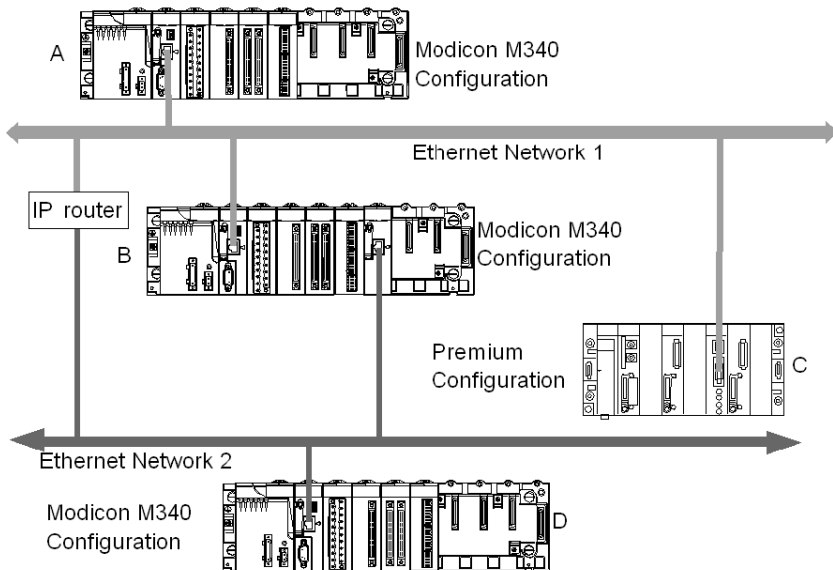

In the diagram above there are the following configurations:

- Three Modicon M340 configurations called A, B and D
- One Premium configuration called C

All the configurations can communicate because of the following statements:

- A and B: communication between two Modicon M340 PLCs on an Ethernet network is possible.
- A and C: communication between a Modicon M340 PLC and a Premium PLC is possible on an Ethernet network.
- A or C, and D: communication between two Modicon M340 PLCs or between a Modicon M340 PLC and a Premium PLC on Ethernet multi-network is possible. An IP router is required.

Example 2

The second example is a multi-network configuration as follows:

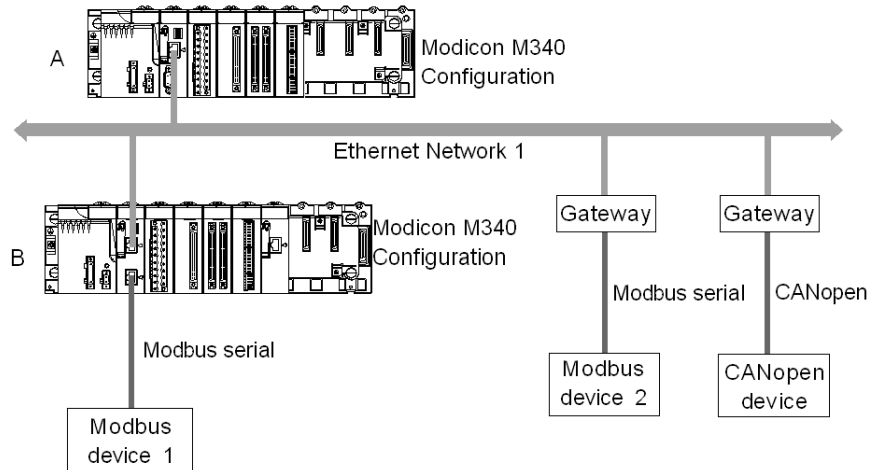

In the diagram above there are two Modicon M340 configurations which are called A and B. The configuration B is directly connected to the Modbus device 1 via Modbus communication channel. Communication between the two Modicon M340 PLCs is possible because the configurations are linked to the same Ethernet network.

Communication between the configuration A and the Modbus device 2 is possible only if you use an Ethernet/Modbus gateway. In case of it is a CANopen device, an Ethernet/CANopen gateway is required.

NOTE: To address the CANopen or the Modbus device 2 on the configuration A you must use the following syntax: `ADDM('Netlink{hostAddr}node')`, the gateway being identified with `hostAddr` field. For example, if the Netlink is set to `Ethernet_1`, the gateway address is `139.160.234.64` and the slave number of the device is set to `247`, the syntax of the `ADDM` function is as follows: `ADDM('Ethernet_1{139.160.230.64}247')`

Chapter 11

General points concerning bridging

Subject of this Chapter

This chapter gives an overview of the different bridging solutions for devices in a communication architecture.

What Is in This Chapter?

This chapter contains the following topics:

Topic	Page
Bridging Description	100
Bridging Example	102

Bridging Description

At a Glance

There are two available connection modes:

- Direct PLC access: Unity Pro connects directly to the PLC.
- Transparent PLC access or bridging: Unity Pro connects to a PLC via a Modicon M340 PLC.

Set Address

The direct PLC access and transparent PLC access features are available via the **Set Address** screen. In this screen, you must enter the PLC address.

To access the **Set Address** screen, use the **Set Address** command on the **PLC** menu.

The **Set Address** screen is as follows:

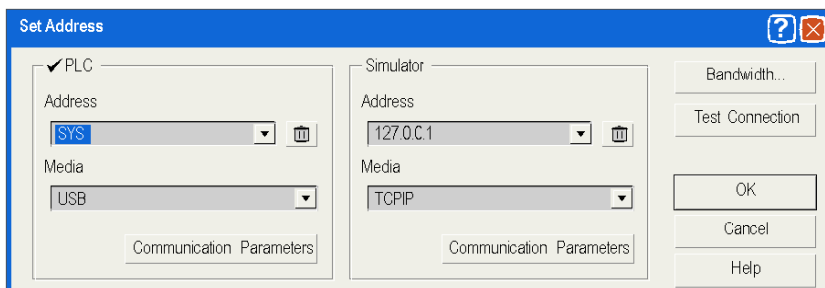

Direct PLC Access Syntax

The available syntaxes for a direct PLC access are described below:

Connection used	Address
USB	SYS or empty
Ethernet	IP address: 139.169.3.4
Modbus	Slave number

Transparent PLC Access Syntax

The bridging address string consists of two parts:

- First part: The "via address" (optional).
- Second part: The "remote PLC address".

The address parameter syntax is:

via address\remote PLC address

The syntax for the "remote PLC address" depends on the network link type:

Network link	Remote PLC address
Modbus slave	Link_address.Modbus Slave Number
Ethernet	Link_address {IP address}
Ethernet device	Link_address.UnitID

"Link_address" is a r.m.c-type topological address where:

- r: rack address.
- m: module address.
- c: channel address.

The "via address" is a classical address depending on the media:

Media	Via address
Modbus slave	Slave_nbr
USB	SYS or empty
Ethernet	IP address

Online Service Limitations of Transparent PLC Access

The transparent PLC access or bridging offers:

- full online services if the remote PLC is a Modicon M340 or a Quantum PLC.
- restricted online services if the remote PLC is a Unity Premium PLC (not all option module screens work).
- no online services for the modules ETY 4103, ETY 5103, WMY 100 and ETY PORT (except embedded Ethernet ports of Premium PLCs P57 4634, P57 5634 and P57 6634).

Bridging Example

At a glance

The following pages present an example of PLC configurations bridging and its transparent PLC addresses.

Bridging Example

The following example consists of the following PLC configurations:

- Configuration 3: this Modicon M340 configuration consists of the following communication modules:
 - An Ethernet-Modbus processor with IP address 139.160.235.34 and Modbus Master. The processor is in slot 0 of the configuration so that the topological address of this processor's Ethernet channel is 0.0.3 and the topological address of this processor's Modbus channel is 0.0.0.
 - An Ethernet module BMX NOE 0100 with IP address 118.159.35.2. The Ethernet module is in slot 5 of the configuration so that the topological address of this Ethernet module's channel is 0.5.0.
- Configuration 1: this configuration consists of a remote PLC linked to processor's Ethernet channel of the configuration 3. The IP address of this remote PLC is 139.160.235.16.
- Configuration 2: this configuration consists of a remote PLC linked to Ethernet module's channel of the configuration 3. The IP address of this remote PLC is 118.159.35.45.
- Configuration 4: this configuration consists of a remote PLC linked to processor's Modbus channel of the configuration 3. The Modbus slave address of this remote PLC is 66.

This diagram presents the bridging example:

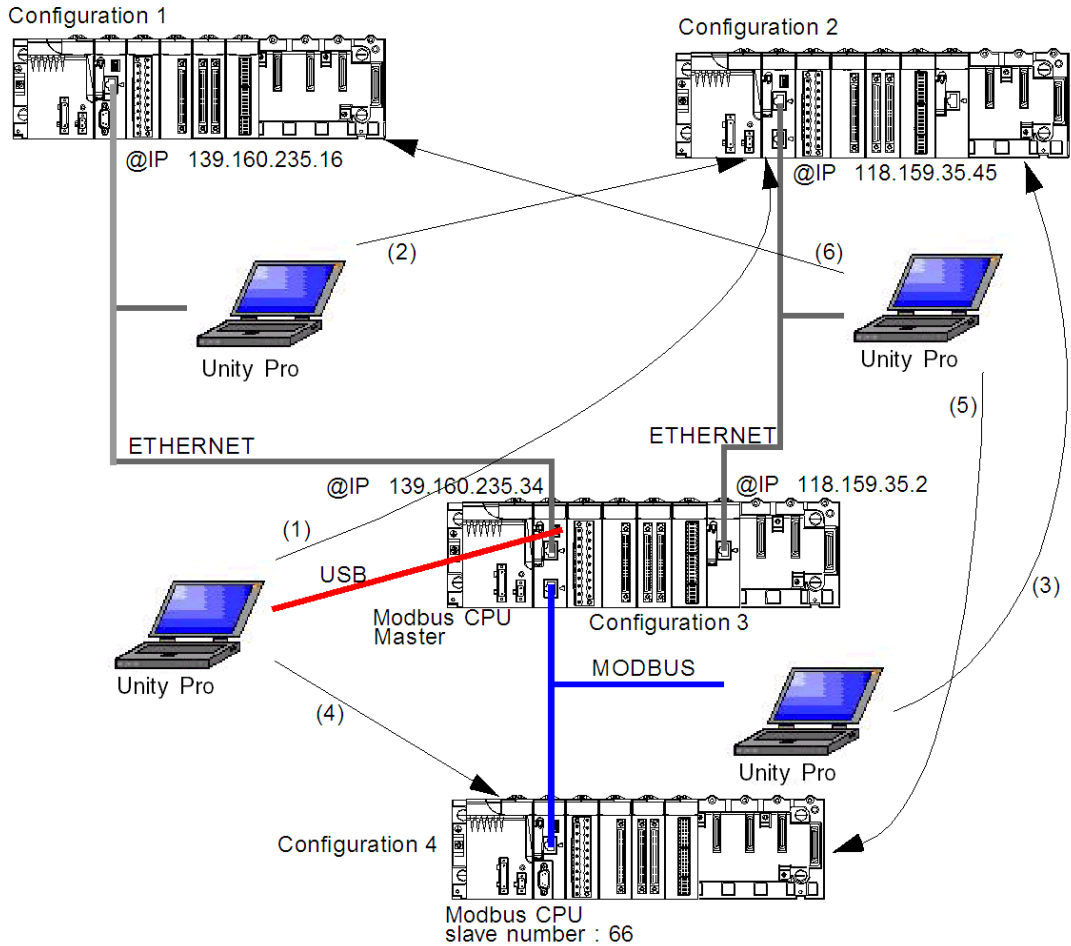

The transparent PLC addresses are as follows:

Bridging configuration	Transparent PLC address
(1) USB connection to remote PLC, which is linked to an Ethernet module	SYS\0.5.0.{118.159.35.45}
(2) processor's Ethernet channel to remote PLC, which is linked to an Ethernet module	139.160.235.34\0.5.0{118.159.35.45}
(3) processor's Modbus channel to remote PLC linked, which is linked to an Ethernet module	5\0.5.0{118.159.35.45}
(4) USB connection to remote PLC, which is linked to processor's Modbus channel	SYS\0.0.0.66
(5) Ethernet module connection to remote PLC, which is linked to processor's Modbus channel	118.159.35.2\0.0.0.66
(6) Ethernet module connection to remote PLC, which is linked to processor's Ethernet channel	118.159.35.2\0.0.3{139.160.235.16}

Part III

Operating Modes

Subject of this Part

This part describes the operating modes associated with expert communication.

What Is in This Part?

This part contains the following chapters:

Chapter	Chapter Name	Page
12	Network Configuration	107
13	Bus Configuration	115
14	Configuration of X-Way Routing Premium Stations	125
15	Debugging	141
16	Communication Function Programming and Entry Help	145

Chapter 12

Network Configuration

Subject of this Chapter

This chapter presents the tools for configuring a network at the global level and at the station level.

What Is in This Chapter?

This chapter contains the following topics:

Topic	Page
Network Configuration Principle Using Unity Pro	108
Creating a Logic Network	109
Configuring a Logic Network	111
Associating a Logic Network with Network Hardware	112

Network Configuration Principle Using Unity Pro

At a Glance

With Unity Pro, the installation of a network takes place from the application browser and from the hardware configuration editor.

The method involves the following four steps:

- creation of a logic network,
- configuration of the logic network,
- declaration of the module or of the PCMCIA card (for Premium),
- association of the card or of the module with the logic network.

These four methods are presented further on in this documentation.

NOTE: The advantage of this method is that from the second step onwards, you can design your communication application (you do not need the hardware to start working) and use the simulator for functional testing of it.

NOTE: The first two steps are carried out in the project browser and the following two in the hardware configuration editor.

This manual introduces the method. For details of the various network configurations, please refer to the following documentation:

- Ethernet configuration for Premium (see *Premium and Atrium Using Unity Pro, Ethernet Network Modules, User Manual*) and Ethernet configuration for Modicon M340 (see *Modicon M340 for Ethernet, Communications Modules and Processors, User Manual*),
- Modbus Plus configuration (see *Premium and Atrium Using Unity Pro, Modbus Plus Network, User Manual*),
- Fipway configuration (see *Premium and Atrium using Unity Pro, Fipway Network, User Manual*).

Creating a Logic Network

At a Glance

The first step in implementing a communication network is to create a logic network.

Creating a Logic Network

The following table describes how to create a network using the project browser.

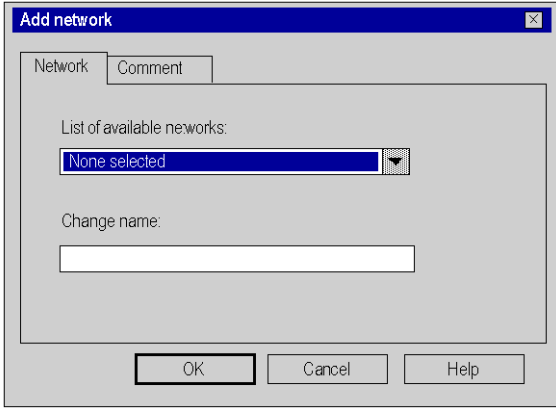
Step	Action
1	<p>Expand the <i>Communication</i> directory in the project browser.</p> <p>Result::</p> 
2	<p>Right-click in the <i>Networks</i> sub-directory and select the New network option.</p> <p>Result::</p> 

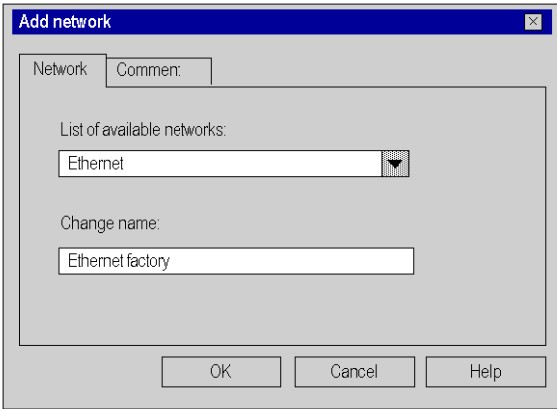
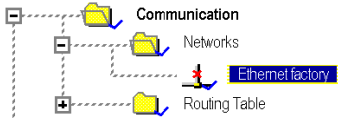
Step	Action
3	<p>Select the network that you want to create from the list of available networks and give it a meaningful name. Result: Example of an Ethernet network:</p>  <p>Note: You can also add a comment, if you so desire, by clicking on the Comment tab.</p>
4	<p>Click OK and a new logic network is created. Result: We have just created the Ethernet network that appears in the project browser</p>  <p>Note: As you can see, a small icon indicates that the logic network is not associated with any PLC hardware. Furthermore, the small blue "v" sign indicates that the project needs to be rebuilt before it can be used in the PLC.</p>

Configuring a Logic Network

At a Glance

The second step in implementing a communication network is to configure a logic network.

This manual introduces the access to network configuration. For information on how to configure the various networks, please refer to the following documentation:

- Ethernet configuration for Premium (see *Premium and Atrium Using Unity Pro, Ethernet Network Modules, User Manual*) and Ethernet configuration for M340 (see *Modicon M340 for Ethernet, Communications Modules and Processors, User Manual*),
- Modbus Plus configuration (see *Premium and Atrium Using Unity Pro, Modbus Plus Network, User Manual*),
- Fipway configuration (see *Premium and Atrium using Unity Pro, Fipway Network, User Manual*).

Configuring a Logic Network

The table below describes how to access the configuration of a network from the project browser.

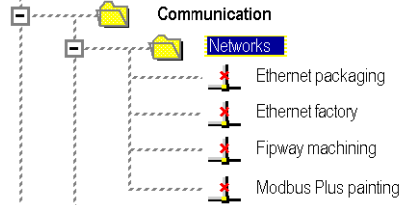
Step	Action
1	<p>In the project browser, expand the directory tree under the Networks sub-tab located in the Communication tab of the tree directory to display all the project networks.</p> <p>Example::</p> 
2	<p>Double-click the network you want to configure to obtain the network configuration window.</p> <p>Note: The windows differ according to the network family selected. However, for all networks, from this window it is possible to configure the Global Data, IPO scanning, Peer Cop utilities, common words, etc.</p> <p>Note: For Ethernet networks, an intermediate step is necessary, which involves selecting the family of the module that will be used in the hardware configuration.</p>

Associating a Logic Network with Network Hardware

At a Glance

The final step in implementing a communication network is to associate a logic network with a network module, Modbus Plus card or Fipway card. Although the screens differ, the procedure is the same for each network device.

How to Associate a Logic Network

The following table describes how to associate a logic network to a network device declared in the hardware configuration editor.

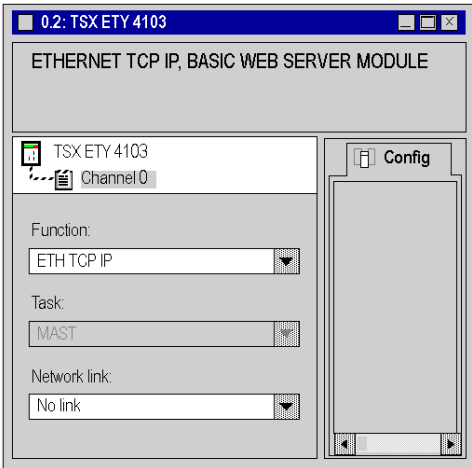
Step	Action
1	Open the hardware configuration editor.
2	Right-click the device (Ethernet module, Fipway PCMCIA card or Modbus Plus PCMCIA card) that you wish to associate with a logical network.
3	<p>Select the channel and function. Result: For a TSX ETY 4103 module:</p> 

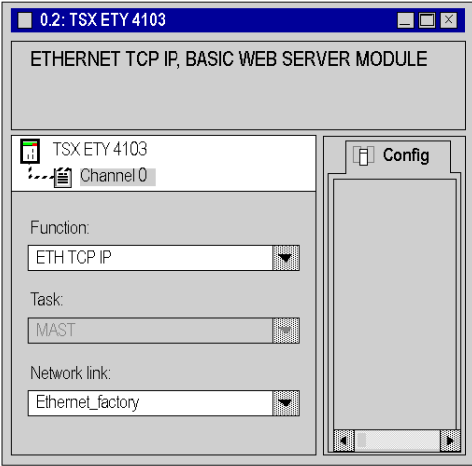
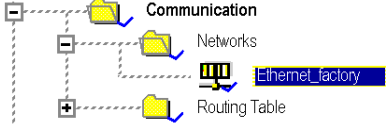
Step	Action
4	<p>In the Network link field, select the network to be associated with the card.</p> <p>Result:</p> 
5	<p>Confirm your choice and close the window.</p> <p>Result: The logic network is associated with the device. The icon associated with this logic network changes and indicates the existence of a link with a PLC. Furthermore, the rack, module and channel numbers are updated in the logic network configuration screen. In our example we obtain the following project browser:</p> 

Chapter 13

Bus Configuration

Subject of this Chapter

This chapter describes how to access bus configuration tools.

What Is in This Chapter?

This chapter contains the following topics:

Topic	Page
Creating and Accessing RIO\IO Field Buses	116
Accessing Bus Configurations on PCMCIA and SCY 21601 Cards	122

Creating and Accessing RIO/DIO Field Buses

Introduction

Quantum PLCs offer a decentralized input/output architecture solution:

- **RIO** field bus networks are based on the S908 input/output decentralization network technology. Up to 31 decentralized stations may be configured, with each station capable of supporting up to 128 input/output words.
- **DIO** field bus networks are based on Modbus Plus technology. 32 subscribers may be configured over 500 meters/1640 feet (receiving 64 subscribers over 2000 meters/6560 feet).

Creating a RIO Bus

The following table describes the procedure for creating a RIO bus from a communication module:

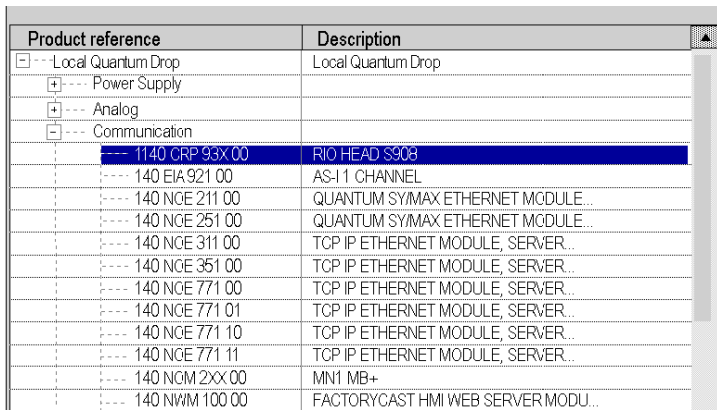
Step	Action
1	In the bus editor, select the slot where you wish to insert the communication module.
2	Select New Device in the contextual menu. Result: The New Device window appears.
3	Expand the <i>Communication</i> directory. Result: The following window appears: 

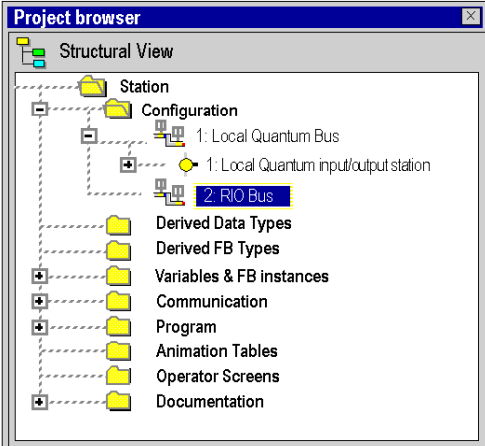
Step	Action
4	<p>To create a RIO bus, select a 140 CRP 93x 00 module.</p> <p>Result: The bus appears in the project browser:</p> 

Creating a DIO Bus

The following table describes the procedure for creating a DIO bus from a communication module:

Step	Action
1	In the bus editor, select the slot where you wish to insert the communication module.
2	<p>Select New Device in the contextual menu.</p> <p>Result: The New Device window appears.</p>

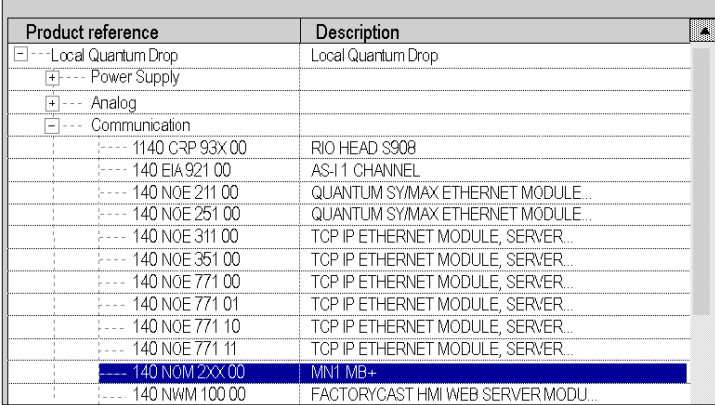
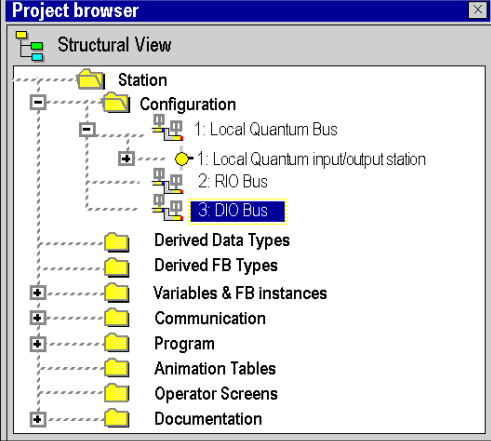
Step	Action																																		
3	<p>Expand the <i>Communication</i> directory. Result: The following window appears:</p>  <table border="1" data-bbox="329 289 1045 691"> <thead> <tr> <th>Product reference</th> <th>Description</th> </tr> </thead> <tbody> <tr> <td>Local Quantum Drop</td> <td>Local Quantum Drop</td> </tr> <tr> <td>Power Supply</td> <td></td> </tr> <tr> <td>Analog</td> <td></td> </tr> <tr> <td>Communication</td> <td></td> </tr> <tr> <td>1140 CRP 93X 00</td> <td>RIO HEAD S908</td> </tr> <tr> <td>140 EIA 921 00</td> <td>AS-I 1 CHANNEL</td> </tr> <tr> <td>140 NOE 211 00</td> <td>QUANTUM SY/MAX ETHERNET MODULE...</td> </tr> <tr> <td>140 NOE 251 00</td> <td>QUANTUM SY/MAX ETHERNET MODULE...</td> </tr> <tr> <td>140 NOE 311 00</td> <td>TCP IP ETHERNET MODULE, SERVER...</td> </tr> <tr> <td>140 NOE 351 00</td> <td>TCP IP ETHERNET MODULE, SERVER...</td> </tr> <tr> <td>140 NOE 771 00</td> <td>TCP IP ETHERNET MODULE, SERVER...</td> </tr> <tr> <td>140 NOE 771 01</td> <td>TCP IP ETHERNET MODULE, SERVER...</td> </tr> <tr> <td>140 NOE 771 10</td> <td>TCP IP ETHERNET MODULE, SERVER...</td> </tr> <tr> <td>140 NOE 771 11</td> <td>TCP IP ETHERNET MODULE, SERVER...</td> </tr> <tr style="background-color: #0000FF; color: white;"> <td>140 NOM 2XX 00</td> <td>MNI MB+</td> </tr> <tr> <td>140 NWM 100 00</td> <td>FACTORYCAST HMI WEB SERVER MODU...</td> </tr> </tbody> </table>	Product reference	Description	Local Quantum Drop	Local Quantum Drop	Power Supply		Analog		Communication		1140 CRP 93X 00	RIO HEAD S908	140 EIA 921 00	AS-I 1 CHANNEL	140 NOE 211 00	QUANTUM SY/MAX ETHERNET MODULE...	140 NOE 251 00	QUANTUM SY/MAX ETHERNET MODULE...	140 NOE 311 00	TCP IP ETHERNET MODULE, SERVER...	140 NOE 351 00	TCP IP ETHERNET MODULE, SERVER...	140 NOE 771 00	TCP IP ETHERNET MODULE, SERVER...	140 NOE 771 01	TCP IP ETHERNET MODULE, SERVER...	140 NOE 771 10	TCP IP ETHERNET MODULE, SERVER...	140 NOE 771 11	TCP IP ETHERNET MODULE, SERVER...	140 NOM 2XX 00	MNI MB+	140 NWM 100 00	FACTORYCAST HMI WEB SERVER MODU...
Product reference	Description																																		
Local Quantum Drop	Local Quantum Drop																																		
Power Supply																																			
Analog																																			
Communication																																			
1140 CRP 93X 00	RIO HEAD S908																																		
140 EIA 921 00	AS-I 1 CHANNEL																																		
140 NOE 211 00	QUANTUM SY/MAX ETHERNET MODULE...																																		
140 NOE 251 00	QUANTUM SY/MAX ETHERNET MODULE...																																		
140 NOE 311 00	TCP IP ETHERNET MODULE, SERVER...																																		
140 NOE 351 00	TCP IP ETHERNET MODULE, SERVER...																																		
140 NOE 771 00	TCP IP ETHERNET MODULE, SERVER...																																		
140 NOE 771 01	TCP IP ETHERNET MODULE, SERVER...																																		
140 NOE 771 10	TCP IP ETHERNET MODULE, SERVER...																																		
140 NOE 771 11	TCP IP ETHERNET MODULE, SERVER...																																		
140 NOM 2XX 00	MNI MB+																																		
140 NWM 100 00	FACTORYCAST HMI WEB SERVER MODU...																																		
4	<p>To create a bus, select a 140 NOM 2XX 00 module. Result: The module appears in the rack.</p>																																		
5	<p>Double-click the 140 NOM 2XX 00 module's Modbus Plus port. Result: The bus configuration window appears.</p>																																		
6	<p>Check the box marked DIO Bus.</p>																																		
7	<p>Confirm the configuration. Result: The DIO bus appears in the project browser.</p> 																																		

Creating a DIO Bus from the Processor

The following table describes the procedure for creating a DIO bus from the processor:

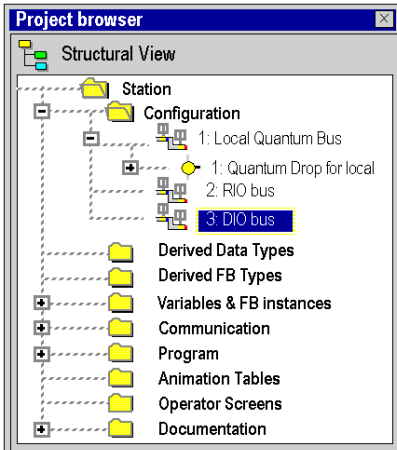
Step	Action
1	In the bus editor, double-click the processor's Modbus Plus port.
2	Check the box marked DIO Bus .
3	<p>Confirm the configuration. Result: The DIO bus appears in the project browser:</p> 

Accessing a RIO or DIO Bus

To access a bus, carry out the following actions:

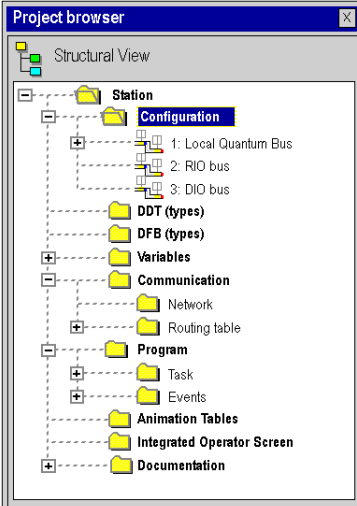
Step	Action
1	<p>In the project browser, open the <i>Configuration</i> directory. Example:</p>  <p>The screenshot shows a 'Project browser' window with a 'Structural View' of a project. The 'Station' folder is expanded, and the 'Configuration' sub-folder is selected and highlighted in blue. Under 'Configuration', three bus types are listed: '1: Local Quantum Bus', '2: RIO bus', and '3: DIO bus'. Other folders visible in the project browser include 'DDT (types)', 'DFB (types)', 'Variables', 'Communication' (with sub-folders 'Network' and 'Routing table'), 'Program' (with sub-folders 'Task' and 'Events'), 'Animation Tables', 'Integrated Operator Screen', and 'Documentation'.</p>

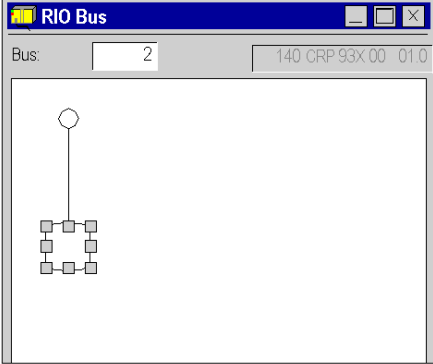
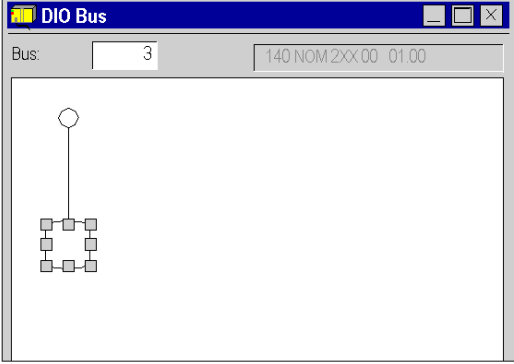
Step	Action
2	<p>Select the <i>RIO bus</i> or <i>DIO bus</i> subdirectory depending on the type of bus you want to open. Next, select the Open command in the popup menu.</p> <p>Result: The following window is displayed for the RIO bus:</p>  <p>Result: The following window is displayed for the DIO bus:</p> 

Accessing Bus Configurations on PCMCIA and SCY 21601 Cards

Introduction

For all communication buses other than those described before, configuration access is done via the hardware configuration of the module (TSX SCY 21601) or PCMCIA card concerned. The following pages describe how to create a new bus by declaring a PCMCIA card, and then how to access the bus configuration.

How to Create a New Communication Bus

The table below describes the actions to be taken to create a communication bus.

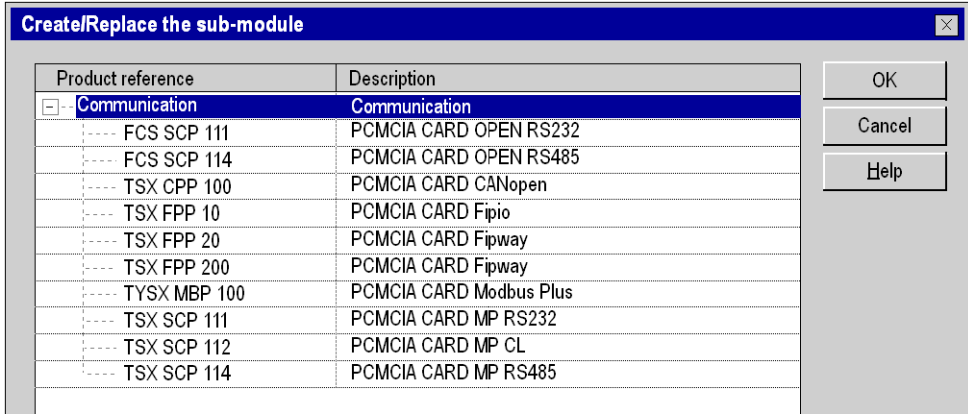
Step	Action																								
1	<p>Double-click the slot of the PCMCIA card that is to manage the desired communication bus (in a TSX SCY 21601 module or in a processor).</p> <p>Result:</p>  <table border="1"> <thead> <tr> <th>Product reference</th> <th>Description</th> </tr> </thead> <tbody> <tr> <td>Communication</td> <td>Communication</td> </tr> <tr> <td>---- FCS SCP 111</td> <td>PCMCIA CARD OPEN RS232</td> </tr> <tr> <td>---- FCS SCP 114</td> <td>PCMCIA CARD OPEN RS485</td> </tr> <tr> <td>---- TSX GPP 100</td> <td>PCMCIA CARD CANopen</td> </tr> <tr> <td>---- TSX FPP 10</td> <td>PCMCIA CARD Fipio</td> </tr> <tr> <td>---- TSX FPP 20</td> <td>PCMCIA CARD Fipway</td> </tr> <tr> <td>---- TSX FPP 200</td> <td>PCMCIA CARD Fipway</td> </tr> <tr> <td>---- TYSX MBP 100</td> <td>PCMCIA CARD Modbus Plus</td> </tr> <tr> <td>---- TSX SCP 111</td> <td>PCMCIA CARD MP RS232</td> </tr> <tr> <td>---- TSX SCP 112</td> <td>PCMCIA CARD MP CL</td> </tr> <tr> <td>---- TSX SCP 114</td> <td>PCMCIA CARD MP RS485</td> </tr> </tbody> </table>	Product reference	Description	Communication	Communication	---- FCS SCP 111	PCMCIA CARD OPEN RS232	---- FCS SCP 114	PCMCIA CARD OPEN RS485	---- TSX GPP 100	PCMCIA CARD CANopen	---- TSX FPP 10	PCMCIA CARD Fipio	---- TSX FPP 20	PCMCIA CARD Fipway	---- TSX FPP 200	PCMCIA CARD Fipway	---- TYSX MBP 100	PCMCIA CARD Modbus Plus	---- TSX SCP 111	PCMCIA CARD MP RS232	---- TSX SCP 112	PCMCIA CARD MP CL	---- TSX SCP 114	PCMCIA CARD MP RS485
Product reference	Description																								
Communication	Communication																								
---- FCS SCP 111	PCMCIA CARD OPEN RS232																								
---- FCS SCP 114	PCMCIA CARD OPEN RS485																								
---- TSX GPP 100	PCMCIA CARD CANopen																								
---- TSX FPP 10	PCMCIA CARD Fipio																								
---- TSX FPP 20	PCMCIA CARD Fipway																								
---- TSX FPP 200	PCMCIA CARD Fipway																								
---- TYSX MBP 100	PCMCIA CARD Modbus Plus																								
---- TSX SCP 111	PCMCIA CARD MP RS232																								
---- TSX SCP 112	PCMCIA CARD MP CL																								
---- TSX SCP 114	PCMCIA CARD MP RS485																								
2	<p>Select the type of bus management card desired.</p> <p>Result: The communication bus is created. It must now be configured - to do so, follow the procedure described in the following paragraph.</p>																								

How to Configure a Communication Bus

The table below describes the actions to be taken to configure a communication bus:

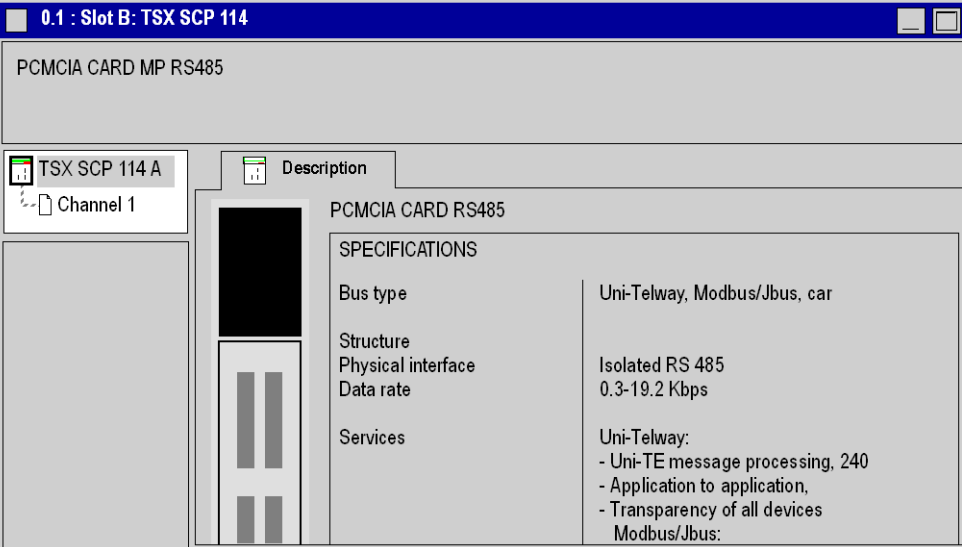
Step	Action										
1	<p>Double-click the slot of the PCMCIA card that is to manage the desired communication bus. Result: A window that resembles the following is displayed:.</p>  <p>The screenshot shows a software window titled "0.1 : Slot B: TSX SCP 114". The window content includes:</p> <ul style="list-style-type: none"> Header: PCMCIA CARD MP RS485 Tree view: <ul style="list-style-type: none"> TSX SCP 114 A <ul style="list-style-type: none"> Channel 1 Description pane: <ul style="list-style-type: none"> PCMCIA CARD RS485 SPECIFICATIONS <table border="1"> <tbody> <tr> <td>Bus type</td> <td>Uni-Telway, Modbus/Jbus, car</td> </tr> <tr> <td>Structure</td> <td></td> </tr> <tr> <td>Physical interface</td> <td>Isolated RS 485</td> </tr> <tr> <td>Data rate</td> <td>0.3-19.2 Kbps</td> </tr> <tr> <td>Services</td> <td> Uni-Telway: <ul style="list-style-type: none"> - Uni-TE message processing, 240 - Application to application, - Transparency of all devices Modbus/Jbus: </td> </tr> </tbody> </table> 	Bus type	Uni-Telway, Modbus/Jbus, car	Structure		Physical interface	Isolated RS 485	Data rate	0.3-19.2 Kbps	Services	Uni-Telway: <ul style="list-style-type: none"> - Uni-TE message processing, 240 - Application to application, - Transparency of all devices Modbus/Jbus:
Bus type	Uni-Telway, Modbus/Jbus, car										
Structure											
Physical interface	Isolated RS 485										
Data rate	0.3-19.2 Kbps										
Services	Uni-Telway: <ul style="list-style-type: none"> - Uni-TE message processing, 240 - Application to application, - Transparency of all devices Modbus/Jbus:										

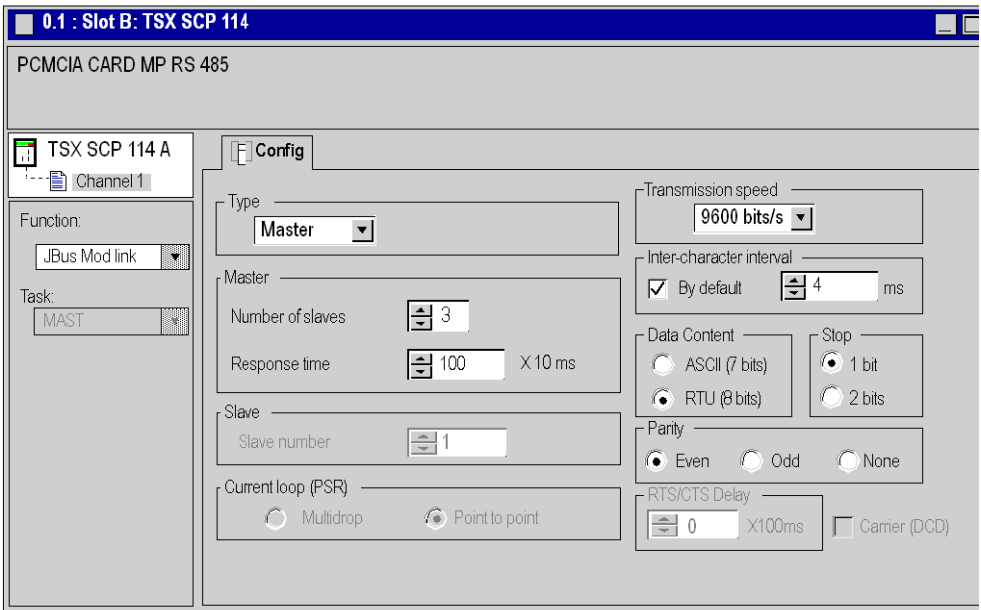
Step	Action
2	<p>Select the channel and the desired function (for example, Modbus). Result: A window that resembles the following is displayed. The bus must now be configured according to the project parameters:.</p>  <p>The screenshot shows a configuration window titled "0.1 : Slot B: TSX SCP 114". Below the title bar, it says "PCMCIA CARD MP RS 485". The main area is divided into several sections:</p> <ul style="list-style-type: none"> Left Panel: Shows "TSX SCP 114 A" and "Channel 1". Under "Function:", "JBus Mod link" is selected. Under "Task:", "MAST" is selected. Config Section: <ul style="list-style-type: none"> Type: "Master" (dropdown) Master: <ul style="list-style-type: none"> Number of slaves: 3 (spinner) Response time: 100 X 10 ms (spinner) Slave: <ul style="list-style-type: none"> Slave number: 1 (spinner) Current loop (PSR): <ul style="list-style-type: none"> <input type="radio"/> Multidrop <input checked="" type="radio"/> Point to point Transmission speed: 9600 bits/s (dropdown) Inter-character interval: <ul style="list-style-type: none"> <input checked="" type="checkbox"/> By default 4 ms (spinner) Data Content: <ul style="list-style-type: none"> <input type="radio"/> ASCII (7 bits) <input checked="" type="radio"/> RTU (8 bits) Stop: <ul style="list-style-type: none"> <input checked="" type="radio"/> 1 bit <input type="radio"/> 2 bits Parity: <ul style="list-style-type: none"> <input checked="" type="radio"/> Even <input type="radio"/> Odd <input type="radio"/> None RTS/CTS Delay: <ul style="list-style-type: none"> 0 X100ms (spinner) <input type="checkbox"/> Carrier (DCD)

Chapter 14

Configuration of X-Way Routing Premium Stations

Subject of this Chapter

This chapter presents the operating modes required for configuring X-Way routing Premium stations.

What Is in This Chapter?

This chapter contains the following topics:

Topic	Page
Configuration	126
Configuration of Multi-Network Services	127
Configuring an X-Way Router Module	129
Examples of X-Way Routing Stations	133
Examples of Partial Routing	137

Configuration

At a Glance

In an intermediate station, the management of several network couplers requires a configuration phase in order to distribute the functional characteristics to the various network entities.

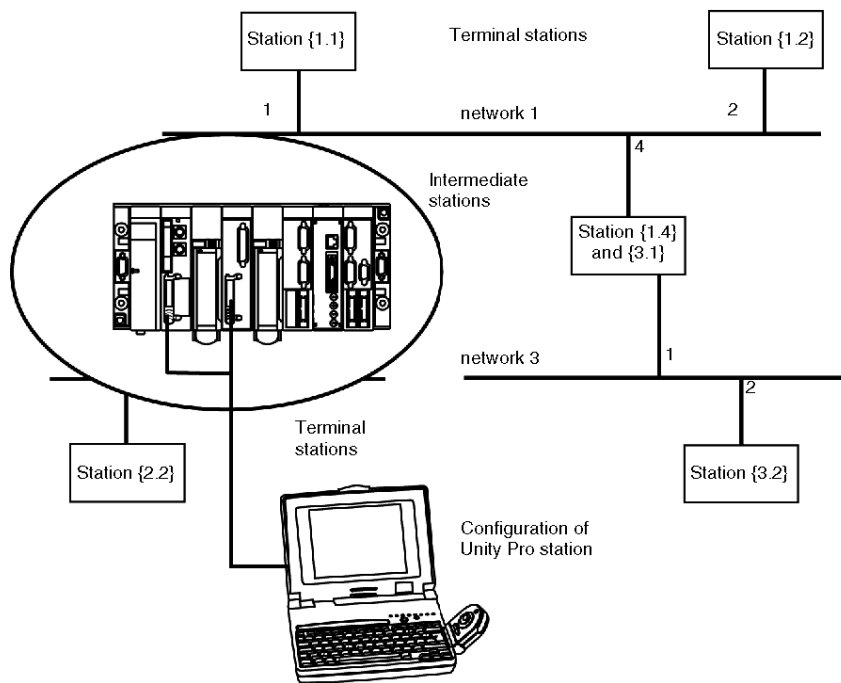

NOTE: Multi-network routing information is constructed at the station level at the time of configuration of each bridge. No consistency check is done on routing data for the same network architecture.

Configuration of Multi-Network Services

At a Glance

In a station that supports various network modules, each network connection point is considered as an address for the station. When configuring each module, it is necessary to define the list of network numbers that are accessible for each connection point.

Depending on the processor selected during hardware configuration, a bridge station can only manage 3 or 4 network modules. The table will therefore have a maximum of 4 elements.

Illustration

A specific screen allows entry of routing data for all the network modules of a station.

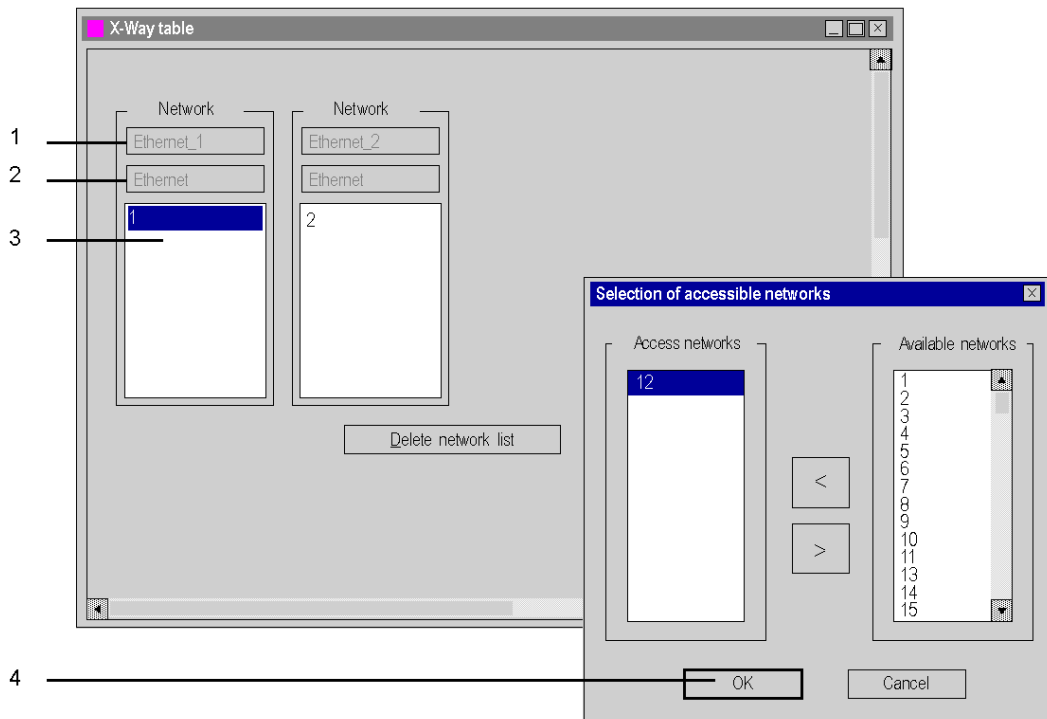

Elements and Functions

The following table describes the various zones in the configuration screen:

Label	Field	Function
1	Logical network	Used to display the logical network name.
2	Network type	Used to display the network type.
3	Accessible networks	Used: <ul style="list-style-type: none"> ● for the unshaded Logical Network zone, to enter the list of networks accessible by this module, ● for the shaded Logical Network zones, to display the list of networks accessible by these modules.
4	Available networks	Used to select the networks accessible by a module configured as a bridge. A list of numbers from 1 to 127 shows the networks available for a connection point. Each network number selected as being accessible is removed from the list of available networks in order to avoid configuration errors.

Configuring an X-Way Router Module

At a Glance

Before configuring the module as an X-Way router, the station's logical networks must be created.

Procedure

The following procedure is used to access, and then configure the station's module as an X-Way router.

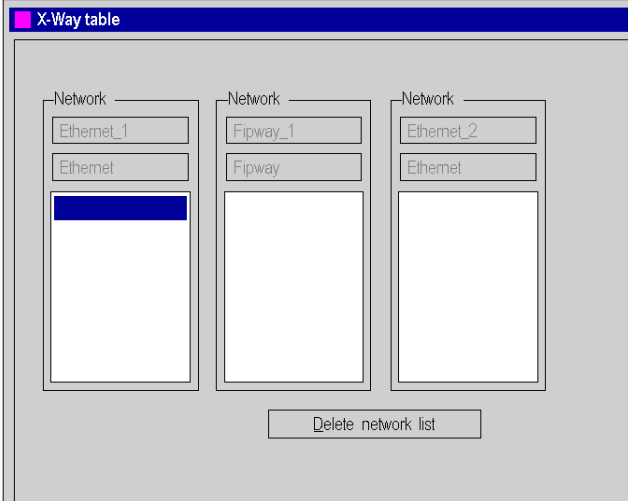
Step	Action
1	<p>Open the Communication tab in your project browser and in the Routing table tab, click the X-Way table tab.</p> <p>Result: The following window appears.</p>  <p>If the list of accessible module networks is empty, the window appears automatically (without double-clicking).</p>

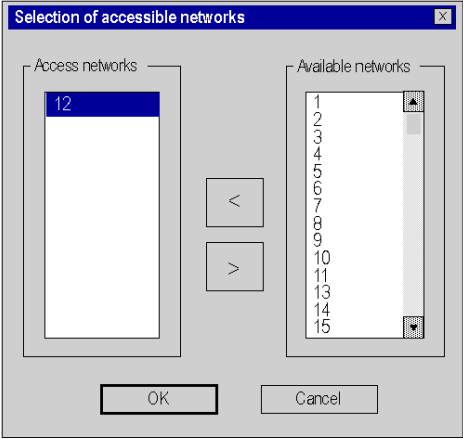
Step	Action
2	<p>Double-click the highlighted field in order to configure the first network. Result: The Selection of accessible networks window appears.</p> 
3	<p>Double-click the number of the required network from the Available networks scroll list. Result: The network number is assigned in the Access networks scroll list.</p>
4	<p>Perform operation 3 as many times as necessary to define all the networks accessible by the module. Once finished, proceed to step 5.</p>
5	<p>Confirm the selection by clicking OK.</p>
6	<p>Confirm the configuration of the X-Way router by closing the window or clicking the Enable button in the toolbar.</p>

Removing the Bridge Function

It is possible to remove the bridge function from the module.

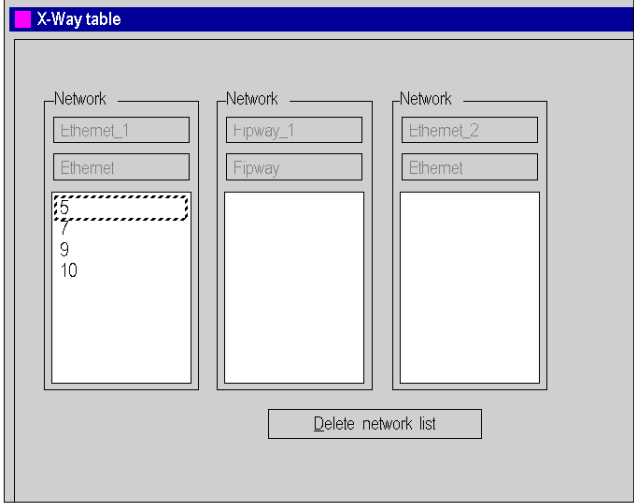
Step	Action
1	Access the following X-Way window. 
2	Click Delete network list .
3	Confirm the configuration

Removing Access to a Network

It is possible to remove access to a single network.

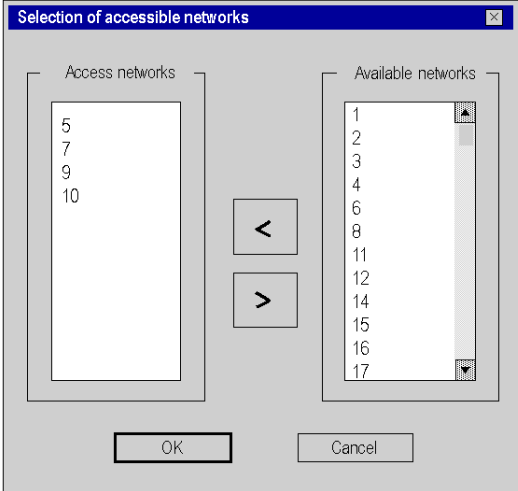
Step	Action
1	<p>Access the following X-Way window of the accessible networks.</p> 
2	<p>Double-click the numbers of the accessible networks to be removed (left column). Result: The network number is reassigned in the Available networks scroll list.</p>
3	<p>Confirm the selection by clicking OK.</p>
4	<p>Confirm the router configuration.</p>

Examples of X-Way Routing Stations

At a Glance

Each station must be configured in order to define the list of accessible networks.

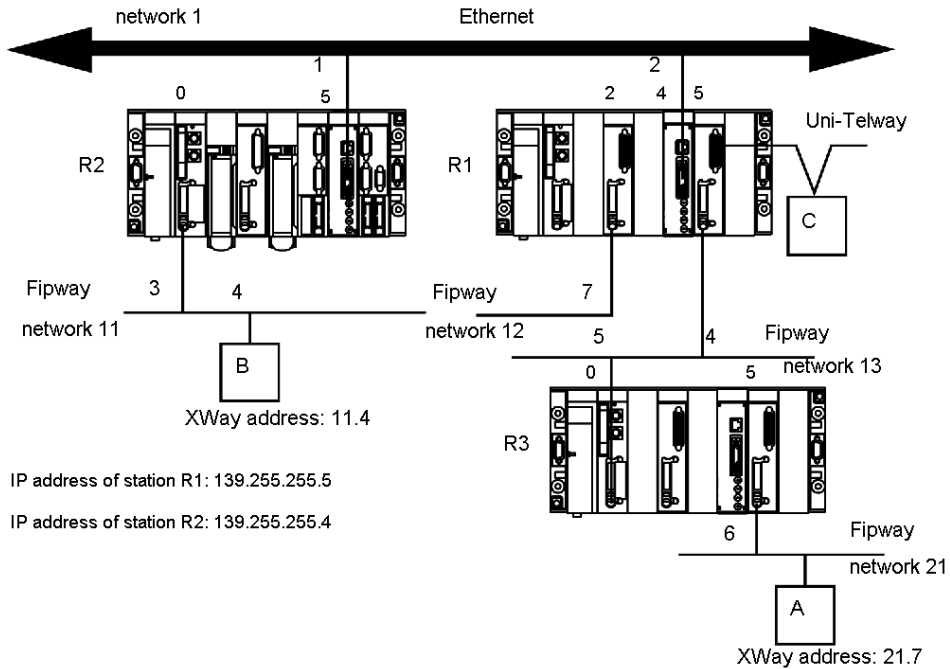

Configuration of Station R1

The module at slot 2 can only access network 12.

The module at slot 4 can only access network 1 and 11.

The module at slot 5 can access networks 13 and 21.

The bridge configuration of the station is therefore as follows:

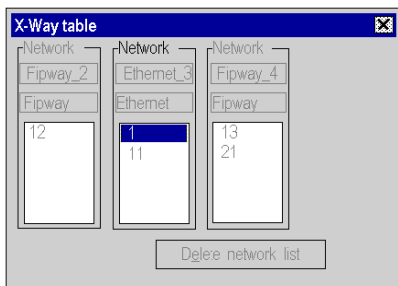

Configuration of Station R2

The module at slot 0 can only access network 11.

The module at slot 5 can access networks 1, 12, 13 and 21.

The bridge configuration of the station is therefore as follows:

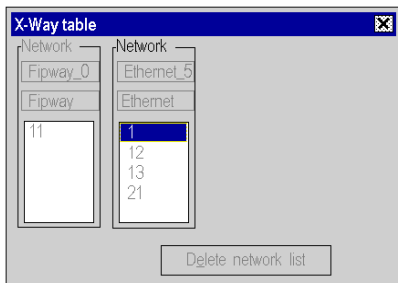

Configuration of Station R3

The module at slot 0 can access networks 13, 12, 1 and 11.

The module at slot 5 can only access network 21.

The bridge configuration of the station is therefore as follows:

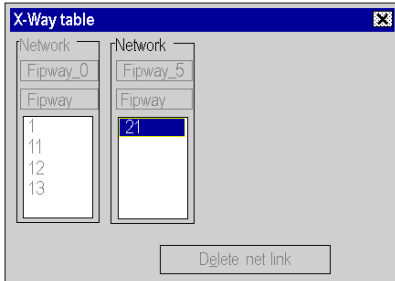

Messaging

To use the communication function (see *Unity Pro, Communication, Block Library*) such as Read_VAR for ethernet exchange between stations, configure the TCP/IP Messaging in the Ethernet network configuration (see *Premium and Atrium Using Unity Pro, Ethernet Network Modules, User Manual*) screen. In the **Messaging** tab, for each exchange set the IP address and target XWay address.

For example if station R3 needs to communicate with station B, in R1 **Messaging** tab:

- set the R2 IP address (139.255.255.4) in the field **IP address**, and
- set the B XWay address (11.4) in the field **XWay address**.

The following illustration shows the R1 **Messaging** tab:

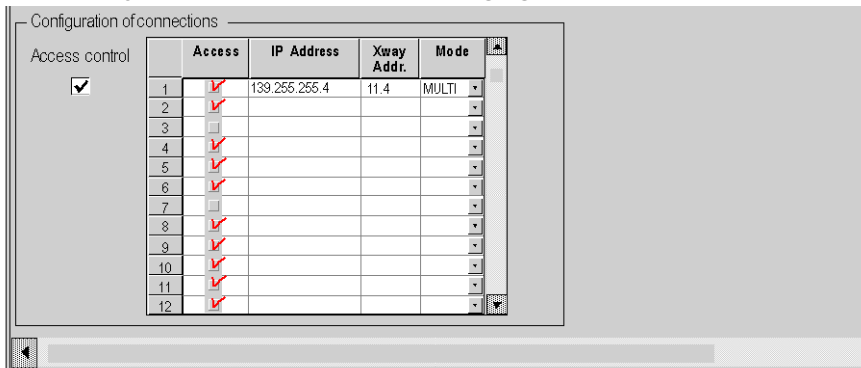

For another example if station B needs to communicate with station A, in R2, **Messaging** tab:

- set the R1 IP address (139.255.255.5) in the field **IP address**, and
- set the A XWay address (21.7) in the field **XWay address**.

The following illustration shows the R2 **Messaging** tab:

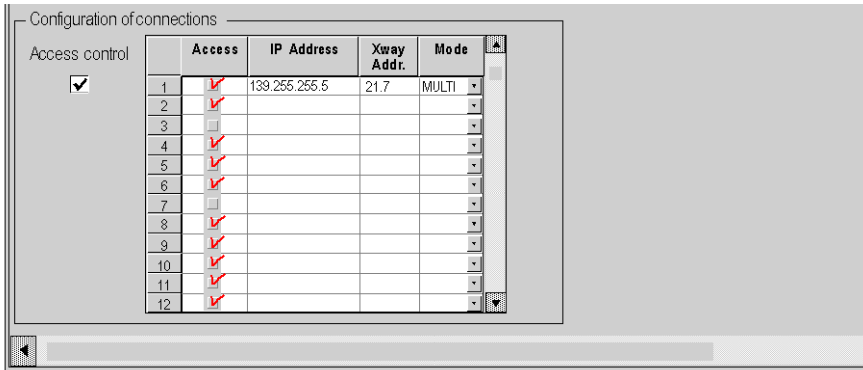

Examples of Partial Routing

At a Glance

When configuring a module as a bridge, it is possible to assign to it only a part of the available networks, instead of all of them. This selection is used to define a partial routing.

Illustration

Each station must be configured in order to define the list of accessible networks.

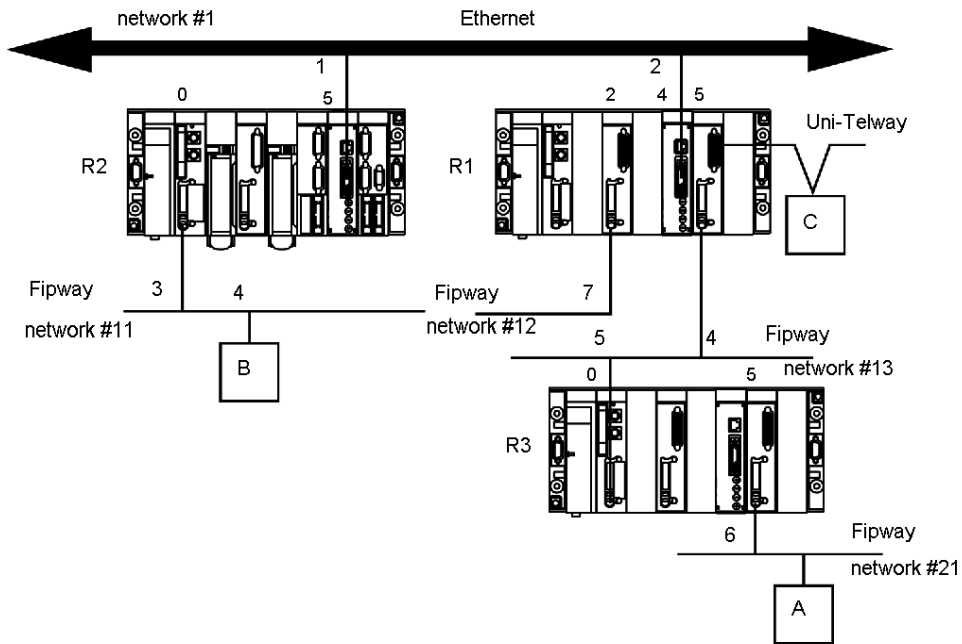

Configuration of Station R1

The module at slot 2 is not involved in the routing of data.

The module at slot 4 can access networks #1 and #11.

The module at slot 5 can access networks #13 and #21.

The bridge configuration of the station is therefore as follows:

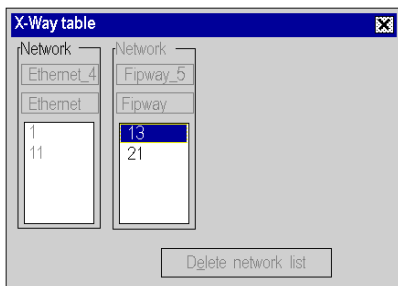

Configuration of Station R2

The module at slot 0 can only access network #11.

The module at slot 5 can access networks #1, #13 and #21. Network #12 is inaccessible.

The bridge configuration of the station is therefore as follows:

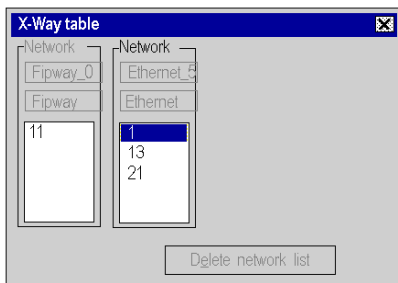

Configuration of Station R3

The module at slot 0 can access networks #13, #1 and #11. Network #12 is no longer accessible.

The module at slot 5 can only access network #21.

The bridge configuration of the station is therefore as follows:

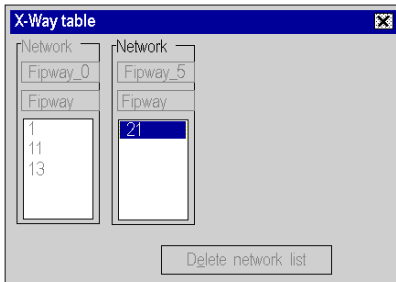

Chapter 15

Debugging

Description of the Communication Debug Screens

At a Glance

The debug screen dedicated to the application-specific communication function is accessible via the **Debug** tab. It has two distinct sections:

- The top left section, which is in all types of debug screens, is dedicated to module and communication channel information.
- The bottom right section is dedicated to debugging data and parameters. This area, which is specific to the type of communication chosen, is detailed in the documentation relating to the various types of communication.

Accessing the Screen

It is only possible to access debug mode in online mode.

Step	Action
1	Access the configuration screen
2	Select Debug mode by clicking the corresponding tab.

Illustration

This area is used to access diagnostics for a communication channel.

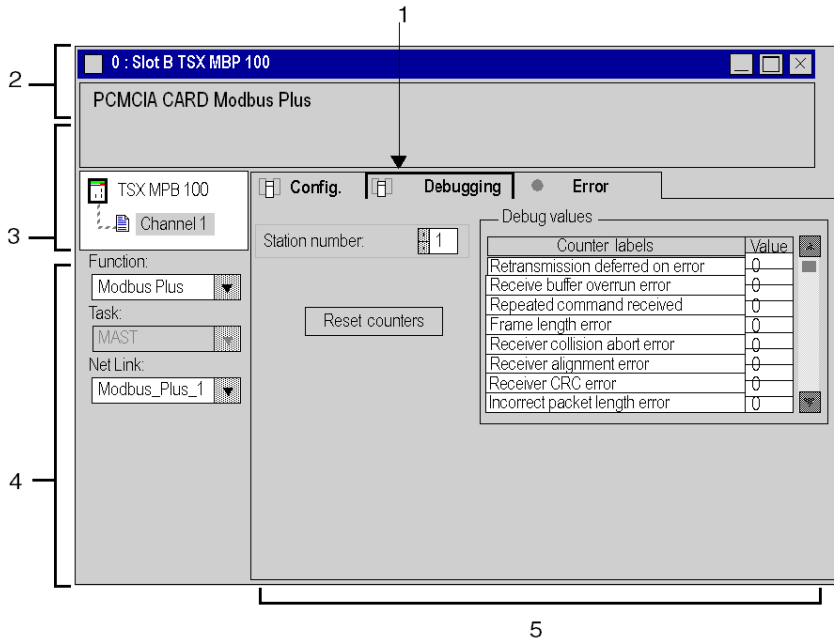

Description

The table below shows the different elements of the debug screen and their functions.

Label	Element	Function
1	Tabs	The tab in the foreground indicates the mode in progress (Debug for this example). You can select each mode by clicking the corresponding tab. The modes available are: <ul style="list-style-type: none"> ● Debug (accessible only in online mode), ● Diagnostic (accessible only in online mode), ● Configuration, ● Settings.
2	Module area	This area displays the abbreviated module indicator. There are three indicators that provide the module's status in online mode: <ul style="list-style-type: none"> ● RUN indicates the module's operating status, ● ERR indicates an internal fault in the module, ● I/O indicates a fault from outside the module, or an application fault.
3	Channel area	This area is used to select the channel to be debugged: <ul style="list-style-type: none"> ● Channel: module channel number. To the left of the symbol there is a copy of the CHx channel LED.
4	General parameters area	This area shows the communication channel parameters: <ul style="list-style-type: none"> ● Function: shows the configured communication function. This information cannot be modified. ● Task: shows the task (configured MAST). This information cannot be modified.
5	Mode parameters area	This area contains the parameters of the mode selected by the tab.

NOTE: All unavailable LEDs and commands appear in gray.

Chapter 16

Communication Function Programming and Entry Help

Subject of this Chapter

This chapter presents the various entry help tools.

What Is in This Chapter?

This chapter contains the following topics:

Topic	Page
Communication Function Entry Help	146
Access a specific instruction of the function, function block or DFB type	147
Address Entry Help	149

Communication Function Entry Help

At a Glance

During programming you can access an entry help screen allowing you to find out all the parameters of a communication function.

This help can be obtained from the Unity Pro library functions.

Illustration

The following illustration shows the entry help screen for the communication function `READ_VAR`.

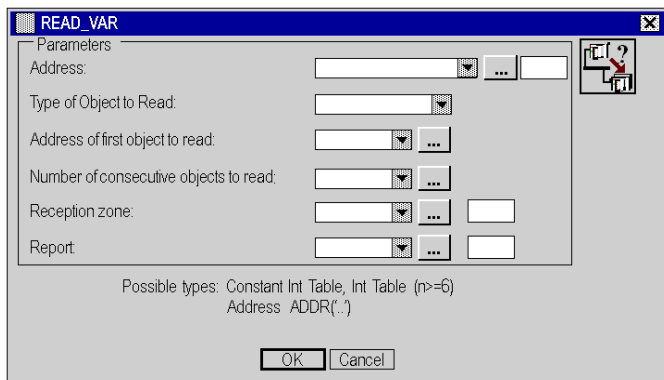

NOTE: The number and type of fields vary according to the communication function selected.

Availability

This screen is available for the following communication functions:

- `DATA_EXCH`
- `INPUT_CHAR`
- `OUT_IN_CHAR`
- `PRINT_CHAR`
- `READ_VAR`
- `SEND_REQ`
- `SEND_TLG`
- `WRITE_VAR`

Access a specific instruction of the function, function block or DFB type

At a Glance

The application-specific function may be accessed:

- by direct entry of the instruction and its parameters in an operate block
- via the entry help function accessible in the program editors (FBD, LD, IL, ST).

Calling a Function

The following table describes how to call a function.

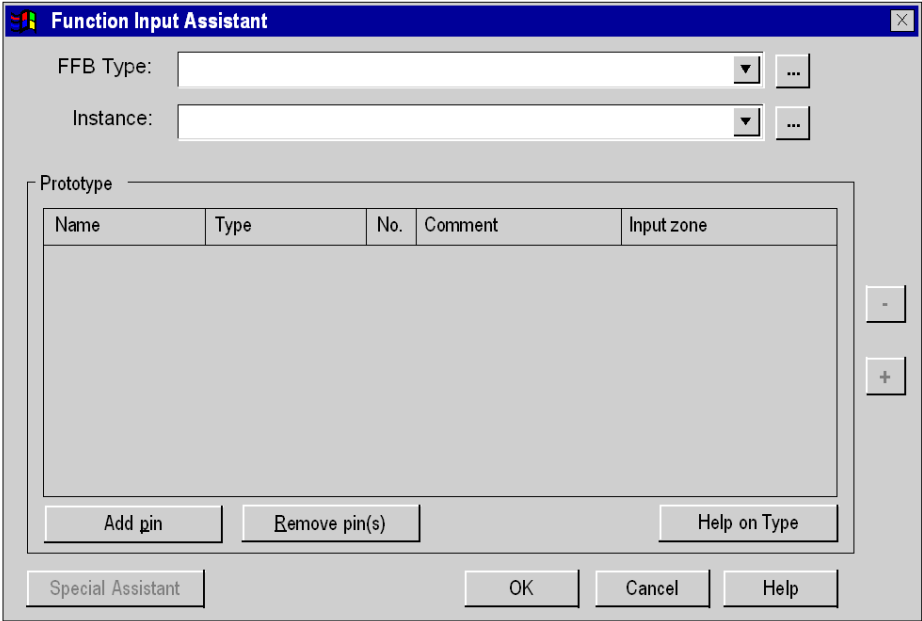
Step	Action
1	Access the required editor.
2	<p>Depending on the editor, select one of the following methods to open the function library:</p> <ul style="list-style-type: none"> • Select the function to enter with the data editor. Once in the editor, right-click on the function (LD, FBD editors). • Right-click in the program editor and select the option FFB Input Assistant. <p>Note: The function input assistant window appears:</p> 
3	Select the type of FFB required (if it is not already entered).
4	Then select the name of the instance (where necessary and if available).

Step	Action
5	Many instructions have a customized entry help screen. You can access this screen by clicking the Special Assistant button.
6	Enter each parameter of the instruction (each instruction is explained in the relevant application-specific documentation): <ul style="list-style-type: none">● in the customized detailed data entry screen,or● in the Prototype area of the Entry field.
7	Confirm by clicking Ok .

Address Entry Help

At a Glance

To assist in entering the address, a help screen is available.

With this screen, a description of the architecture in which the communication function is integrated and generated can be added. By completing the fields of this description, the address is automatically generated.

Accessing the Help

When entering the parameters of the communication function, you can access the address entry help with the following button:



Illustration

The following illustration shows the address input help screen for a communication function.

Help for Address Entry

Mode: Local Remote Address Generated: ADR#0.01.0.0.1

Network level

Network Selection: Number: 0 Station Selection: Number: 0 Type: TSX37

Station level

Destination station: TSX37

Go to:

- Module
- System
- Application

Module:

Rack: 0

Module: 0

Channel 0 Channel 1 Channel 2

Type:

- Master
- Slave
- FIP Manager
- FIP Agent

Device level

Protocol: UNI_TELWAY

Destination Device:

Broadcast

Slave no.: 1

Type:

- Master
- Slave
- FIP Manager
- FIP Agent

OK Cancel

Mode

The first parameter to select is the **Mode**. With it you can select one of the following communication modes:

- local (communication by bus)
- remote (communication by network)

Network Level

For remote communications only, the **network level** is used to:

- enter the network number,
- enter the station number,
- select the station type.

Station Level

Depending on the communication function, with this parameter the type of exchange can be selected:

- The **Application** box selects an exchange with a PL7 application (corresponds to APP addressing).
- The **System** box selects the PLC system of the station designated by the network level (corresponds to SYS addressing).
- The **Module** box means that the destination device is connected to the station via a link (Uni-Telway, Modbus, Modbus Plus or Fipio). This case requires you to specify:
 - the position of the module supporting this link,
 - the type of this module.

Protocol

The **Protocol** field defines the exchange protocol used between the station on the network and the exchange's destination device.

Device Level

This parameter is used to specify:

- the type of destination device,
- the address of this device.

Limitations

In the address entry help screen, communications from a Uni-Telway slave require coding of the destination address in the transmission buffer (see *Unity Pro, Communication, Block Library*).

The help window allows full entry of the section corresponding to `ADDR()` advising the user that the additional buffer must be coded.

Remote station address coding is only supported by the following devices: TSX 17, TSX 37, TSX 47-107, TSX 57.

For third-party devices, only entry of the port number is proposed. In other cases the address must be entered manually.



A

addressing, 71
 assistant, 145
 IP, 63
 Modbus Plus, 67
 Modicon M340, 85
 Premium, 71
ALL, 74
APP, 74
architectures, 41

B

brigde, 99
broadcast
 Modicon M340, 86
 Premium, 75

C

Communication
 Entry help, 146
configuring field buses, 115
configuring networks, 107
configuring X-way, 125

D

Debug screen, 141

E

Entry help, 146

G

Global Data, 19

I

IO Scanning, 19

M

messaging, 19

P

Peer Cop, 19

S

SYS, 74

T

topologies, 41

X

X-Way
 message routing, 51

