

Kramer Electronics, Ltd.



USER MANUAL

Model:

VP-885

8x8 Multiformat Video / Balanced Audio Matrix Switcher

Contents

1	Introduction	1
2	Getting Started	1
2.1	Quick Start	1
3	Overview	3
3.1	Terminology Used in this Manual	4
4	Defining the VP-885	5
4.1	Using the IR Transmitter	8
5	Installing the VP-885 in a Rack	9
6	Connecting the VP-885	10
6.1	Connecting a Balanced/Unbalanced Stereo Audio Input/Output	11
6.2	Connecting to the VP-885 via RS-232	12
6.3	Connecting to the VP-885 via RS-485	13
6.4	Connecting to the VP-885 via Ethernet	13
6.4.1	Connecting Directly via the Ethernet Port	14
6.4.2	Connecting via a Network Hub, Switch, or Router	16
6.4.3	Configuring the Ethernet Port on the VP-885	16
6.5	Setting the VP-885 DIP-switches	18
7	Operating the VP-885	19
7.1	Displaying the Configuration of the VP-885	19
7.2	Switching Outputs to Inputs	19
7.3	Confirming Settings	20
7.3.1	Toggleing between At Once and Confirm Modes	20
7.3.2	Confirming a Switching Action	20
7.4	Defining the 7-Segment Status Display Information	21
7.4.1	Status Display Immediately After Power is Turned On	21
7.4.2	Status Display During Normal Operation	22
7.4.3	Status Display During Audio Gain Level Setting	22
7.5	Choosing the Audio-Follow-Video or Breakaway Option	23
7.5.1	Setting the Audio-Follow-Video Option	23
7.5.2	Setting the Breakaway Option	23
7.6	Storing/Recalling Input-Output Configurations	23
7.6.1	Storing an Input-Output Configuration	24
7.6.2	Recalling an Input-Output Configuration	24
7.6.3	Deleting an Input-Output Configuration	24
7.7	Audio Input/Output Gain Control	24
7.8	Resetting the Unit	26
8	Controlling the VP-885	26
8.1	Controlling the VP-885 via RS-232	26
8.2	Controlling the VP-885 via RS-485	28

8.3	Controlling the VP-885 via Ethernet	28
9	Updating the Firmware	30
10	Connecting to the VP-885 via your Browser	30
10.1	The Main Switching Matrix Page	32
10.1.1	Switching an Input to an Output	32
10.1.2	Setting the AFV Mode	33
10.1.3	Operating in the Offline Mode	34
10.1.4	Storing and Recalling Setups	35
10.1.5	Locking the Front Panel Buttons	37
10.2	Audio Input Gain Control Page	38
10.3	The Configuration Page	38
11	Communication Parameters	40
12	Technical Specifications	41
13	Tables of ASCII Codes for Serial Communication (Protocol 3000)	42
14	Tables of Hex Codes for Serial Communication (Protocol 2000)	43
15	Kramer Protocol	45
15.1	Switching Protocols	45
15.1.1	Switching Protocols via the Front Panel Buttons	45
15.1.2	Switching Protocols via Protocol Commands	45
15.2	Kramer Protocol 3000	45
15.2.1	Protocol 3000 Syntax	46
15.2.2	Command Parts Details	46
15.3	Kramer Protocol 2000	53

Figures

Figure 1: VP-885 8x8 Multifformat Video/Balanced Audio Matrix Switcher Front Panel	5
Figure 2: VP-885 8x8 Multifformat Video/Balanced Audio Matrix Switcher Rear Panel	7
Figure 3: Connecting the VP-885	10
Figure 4: Wiring a Balanced Stereo Audio Input/Output	11
Figure 5: Wiring an Unbalanced Stereo Audio Output	12
Figure 6: Wiring an Unbalanced Source to a Balanced Input	12
Figure 7: Connecting to the VP-885 via RS-232 using a PC	12
Figure 8: Connecting to the VP-885 via Ethernet	14
Figure 9: Local Area Connection Properties Window	15
Figure 10: Internet Protocol (TCP/IP) Properties Window	15
Figure 11: Connect Window	16
Figure 12: Device Properties Window	17
Figure 13: VP-885 DIP-switches	18
Figure 14: Status Display Immediately After Turn On	21
Figure 15: Status Display 5 Seconds After Turn On	22
Figure 16: Status Display During Normal Operation	22
Figure 17: Status Display Showing OUTPUT 3, Gain -4.5	22
Figure 18: Configuration Button Numbering	24

Figure 19: Status Display OUTPUT 8 Flashing	25
Figure 20: Status Display Showing OUTPUT 8, Gain -4.5	25
Figure 21: Control Configuration via RS-232	27
Figure 22: Controlling the VP-885 via Ethernet	29
Figure 23: Entering the IP Number in the Address Bar	30
Figure 24: The Loading Page	30
Figure 25: First Time Security Warning	31
Figure 26: Main Switching Matrix Page	32
Figure 27: Selecting a Switching Point on the Matrix	33
Figure 28: Switching an Input to an Output	33
Figure 29: AFV Mode Warning	34
Figure 30: AFV Mode Audio Channels Switched	34
Figure 31: Switching Audio in the Offline Mode	35
Figure 32: Exiting Offline Warning	35
Figure 33: Selecting Preset 07	36
Figure 34: Selecting Preset 03	37
Figure 35: Recalling a Preset in Offline Mode	37
Figure 36: Audio Gain Control Page	38
Figure 37: Selecting Audio Input Gain for Channel 2	38
Figure 38: Configuration Page	39

Tables

Table 1: Terminology Used in this User Manual	4
Table 2: VP-885 Front Panel Features	6
Table 3: VP-885 Rear Panel Features	8
Table 4: DIP-switch Settings	18
Table 5: Machine Number DIP-switch Settings	18
Table 6: Communication Parameters	40
Table 7: Technical Specifications for the VP-885	41
Table 8: VP-885 Video Signal Codes	42
Table 9: VP-885 Audio Signal Codes	42
Table 10: VP-885 Audio Input Gain Codes	42
Table 11: VP-885 Audio Output Gain Codes	43
Table 12: VP-885 Hex Codes that Switch Video Channels	43
Table 13: VP-885 Hex Codes that Switch Audio Channels	43
Table 14: VP-885 Hex Codes that Increase/Decrease Audio Input Gain	44
Table 15: VP-885 Hex Codes that Set the Audio Input Gain	44
Table 16: VP-885 Hex Codes that Increase/Decrease the Audio Output Gain	44
Table 17: VP-885 Hex Codes that Set the Audio Output Gain	44
Table 18: Instruction Codes for Protocol 3000	47
Table 19: Protocol Definitions	53
Table 20: Instruction Codes for Protocol 2000	54

1 Introduction

Welcome to Kramer Electronics! Since 1981, Kramer Electronics has been providing a world of unique, creative, and affordable solutions to the vast range of problems that confront the video, audio, presentation, and broadcasting professional on a daily basis. In recent years, we have redesigned and upgraded most of our line, making the best even better! Our 1,000-plus different models now appear in 11 groups¹ that are clearly defined by function.

Congratulations on purchasing your **VP-885 8x8 Multiformat Video/Balanced Audio Matrix Switcher** which is ideal for the following typical applications:

- Professional display systems requiring a true 8x8 computer graphics and audio matrix operation
- Multimedia and presentation source, and acceptor selection

The package includes the following items:

- **VP-885 8x8 Multiformat Video/Balanced Audio Matrix Switcher**
- Windows®-based Kramer Control software²
- Kramer **RC-IR3** Infrared Remote Control Transmitter (including the required battery and a separate user manual⁴)
- Power cord³ and this user manual⁴

2 Getting Started

We recommend that you:

- Unpack the equipment carefully and save the original box and packaging materials for possible future shipment
- Review the contents of this user manual
- Use Kramer high performance high-resolution cables⁵

2.1 Quick Start

The following quick start chart summarizes the basic steps when connecting a **VP-885**.

1 GROUP 1: Distribution Amplifiers; GROUP 2: Switchers and Matrix Switchers; GROUP 3: Control Systems; GROUP 4: Format/Standards Converters; GROUP 5: Range Extenders and Repeaters; GROUP 6: Specialty AV Products; GROUP 7: Scan Converters and Scalers; GROUP 8: Cables and Connectors; GROUP 9: Room Connectivity; GROUP 10: Accessories and Rack Adapters; GROUP 11: Sierra Products

2 Download from our Web site at <http://www.kramerelectronics.com>

3 We recommend that you use only the power cord that is supplied with this machine

4 Download up-to-date Kramer user manuals from our Web site at <http://www.kramerelectronics.com>

5 The complete list of Kramer cables is on our Web site at <http://www.kramerelectronics.com>

Step 1: Mount the machine - see section 5

Mount the machine in a rack or stick the 4 rubber feet to the underside

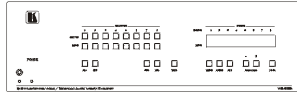

Step 2: Connect the inputs and outputs - see section 6

Connect the video and audio inputs*

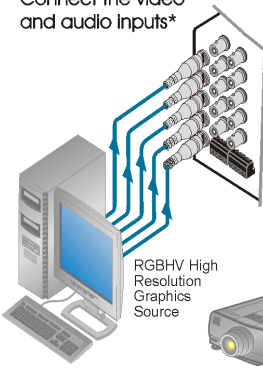

Connect the video and audio outputs*

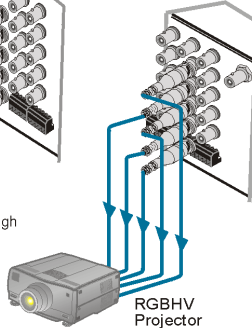

Set the DIP-switches

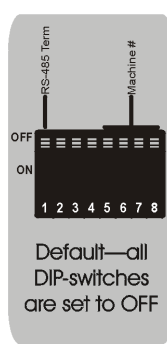

If required, connect the Ext Sync



*Audio connections are not shown

Step 3: Connect the control port - see section 6

Connect an optional RS-232, RS-485 and/or the ETHERNET Control Port

Step 4: Turn the power ON

Step 5: Set the machine - see section 7

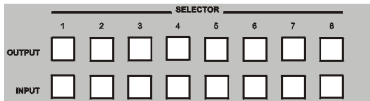

Use the SELECTOR buttons to switch the inputs to the outputs



Read the STATUS on the 7-segment display



Connect a selected Input to all the outputs



Disconnect an output



Confirm actions



VIDEO - Switching relates to the video signal
AUDIO - Switching relates to the audio signal
AFV - Audio follows video when switching



Store (STO) and recall (RCL) actions

Step 6: Operate the machine

Operate via the front panel buttons, IR remote control, RS-485, RS-232, or ETHERNET

3 Overview

The high performance **VP-885** is a multiformat matrix switcher for composite video, s-Video, component video (Y, Cb/Pb, and Cr/Pr), balanced stereo audio, and S/PDIF digital audio signals. It can route any or all inputs to any or all outputs simultaneously. The **VP-885** *8x8 Multiformat Video/Balanced Audio Matrix Switcher* features:

- High Bandwidth (350MHz @-3dB) fully loaded
- HDTV compatibility
- A TAKE button to execute multiple switches all at once
- Memory locations that can be used to store multiple switches as presets to be recalled and executed when needed
- Audio (analog) breakaway switching, for switching audio independently from video

The **VP-885** is housed in a 19" 3U rack mountable enclosure.

In addition, the **VP-885** can be used for mixed video applications such as CV, Y/C and YUV simultaneously.

Control the VP-885 using the front panel buttons, or remotely via:

- RS-485 or RS-232 serial commands (using Kramer 2000 and 3000 protocols) transmitted by a touch screen system, PC, or other serial controller
- The Kramer infrared remote control transmitter **RC-IR3** (included) or infrared remote extension cable transmitter (optional)
- The Ethernet port

To achieve the best performance:

- Use only good quality connection cables¹ to avoid interference, deterioration in signal quality due to poor matching, and elevated noise levels (often associated with low quality cables).
- Avoid interference from neighboring electrical appliances that may adversely influence signal quality and position your Kramer **VP-885** away from moisture, excessive sunlight and dust

¹ Available from Kramer Electronics on our Web site at <http://www.kramerelectronics.com>

3.1 Terminology Used in this Manual

[Table 1](#) defines some terms that are used in this Manual.

Table 1: Terminology Used in this User Manual

TERM	DEFINITION
802.3	The standard specification for ETHERNET that is maintained by the Institute of Electrical and Electronics Engineers (IEEE).
Dynamic Host Configuration Protocol (DHCP)	Allows the network administrator to distribute IP addresses from a central point and automatically send a new IP address when an Ethernet point is plugged into a different network location.
Gateway	A network position serving as an entry to another network. On the Internet, a node or stopping point can be either a gateway node or a host (end-point) node.
IP Address	A 32-binary digit number that identifies each sender or receiver (within a network via a particular server or workstation) of data (HTML pages or e-mails) that is sent in packets across the Internet. Every device connected to an IP network must have a unique IP address. This address is used to reference the specific unit.
Local Area Network (LAN)	Computers sharing a common communications line or wireless link, which often share a server within a defined geographic area.
Media Access Control (MAC) Address	A computer's unique hardware number (or address) in a LAN or other network. On an Ethernet LAN, the (MAC) address is identical to the Ethernet address.
Transmission Control Protocol/Internet Protocol (TCP/IP)	The basic communication language or protocol of the Internet that breaks the message into appropriately sized packets for the network, and can be used as a communications protocol in an intranet or an extranet.

4 Defining the VP-885

Figure 1 and Table 2 define the front panel of the VP-885.

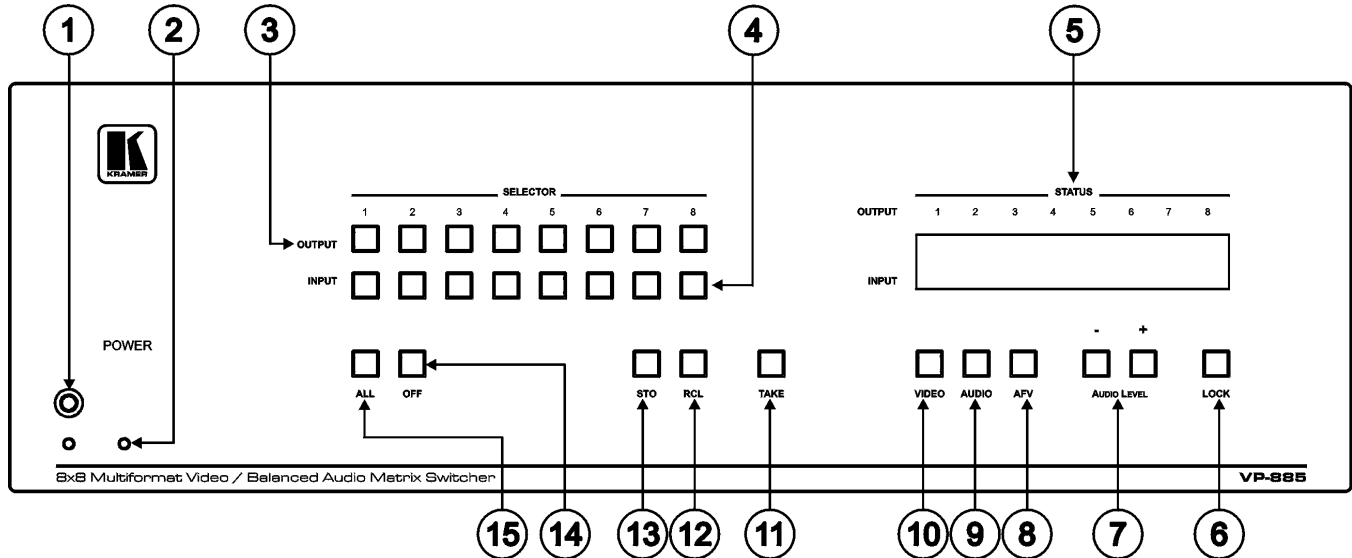

Figure 1: VP-885 8x8 Multifomat Video/Balanced Audio Matrix Switcher Front Panel

Table 2: VP-885 Front Panel Features

#	FEATURE	FUNCTION
1	IR Receiver	LED lights yellow when receiving signals from the Kramer infrared remote control transmitter
2	POWER LED	LED lights green when the unit is ON
3	OUTPUT SELECTOR Buttons	Select the output to which the input is switched
4	INPUT SELECTOR Buttons	Select the input to switch to the output
5	INPUT STATUS Display	Displays the selected input switched to the output (marked above each input)
6	LOCK Button	Press to disable/enable all buttons on the front panel
7	AUDIO LEVEL Buttons	Lights when pressed and actions relate to audio
8	AFV Button	Lights when pressed and actions relate to the video and audio channels. The audio channels follow the video channels
9	AUDIO Button	Lights when pressed and actions relate to audio
10	VIDEO Button	Lights when pressed and actions relate to video
11	TAKE	Press to toggle between the Confirm mode ¹ and the At Once mode (see Section 7.3)
12	RCL Button	Press the RCL button followed by an INPUT button ² to recall a setup from the non-volatile memory
13	STO Button	Press the STO button followed by an INPUT button ² to store the current settings
14	OFF Button	An OFF-OUTPUT combination disconnects that output from the inputs; an OFF-ALL combination disconnects all the outputs
15	ALL Button	Press ALL followed by an INPUT button to connect that input to all the outputs

¹ When in the Confirm mode, the TAKE button flashes

² In this case the INPUT button corresponds to the setup address number

Figure 2 and Table 3 define the rear panel of the VP-885.

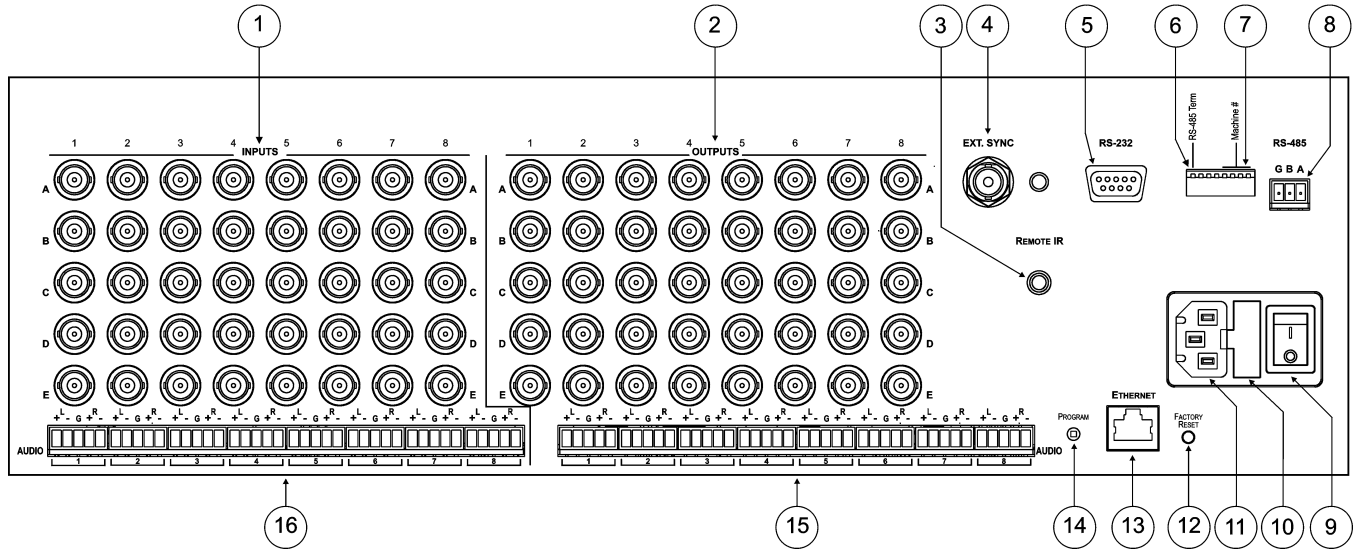

Figure 2: VP-885 8x8 Multifformat Video/Balanced Audio Matrix Switcher Rear Panel

Table 3: VP-885 Rear Panel Features

#	FEATURE	FUNCTION														
1	INPUTS BNC Connectors	Connect to the composite video (Video/Y) and digital audio (S/PDIF/C) sources, or to the s-Video (Video/Y and S/PDIF/C) sources, or to the component video (Y, CB/PB, CR/PR) sources														
2	OUTPUTS BNC Connectors	Connect to the composite video (Video/Y) and digital audio (S/PDIF/C) acceptors, or to the s-Video (Video/Y and S/PDIF/C) acceptors, or to the component video (Y, CB/PB, CR/PR) acceptors														
3	REMOTE IR 3.5mm Mini Jack	Connect to an external IR receiver unit for controlling the machine via an IR remote controller (instead of using the front panel IR receiver) ¹														
4	EXT. SYNC BNC Connector	Connects to the external sync source														
5	RS-232 9-pin D-sub Port	Connects to the PC or the remote controller														
6	RS-485 Term Switch	Terminates the RS-485 if this is the only or last unit														
7	Machine # DIP-switches	DIP-switches for setup of the unit (1, 2 and 3 are for setting the machine number; 4 is for RS-485 bus termination; 5 is for Reply; 8 is for RS-485 PC communication)														
8	RS-485 Port	Pin G is for the Ground connection ² ; pins B (-) and A (+) are for RS-485														
9	Mains Power Switch	Illuminated switch for turning the unit ON and OFF														
10	Mains Fuse Holder	Contains the mains fuse														
11	Mains Power Socket	Socket for mains power cable														
12	FACTORY RESET Button	Press and hold while powering up the unit to reset the audio, switching and Ethernet settings to their factory default values: <table border="1" data-bbox="400 703 987 895"> <tr> <td>IP address</td> <td>192.168.1.39</td> </tr> <tr> <td>Mask</td> <td>255.255.255.0</td> </tr> <tr> <td>Gateway</td> <td>192.168.1.1</td> </tr> <tr> <td>Audio gain for all inputs and outputs</td> <td>0dB</td> </tr> <tr> <td>All switching configuration</td> <td>Erased</td> </tr> <tr> <td>Display</td> <td>1, 2, 3, 4, 5, 6, 7, 8</td> </tr> <tr> <td>Audio mode</td> <td>AFV</td> </tr> </table>	IP address	192.168.1.39	Mask	255.255.255.0	Gateway	192.168.1.1	Audio gain for all inputs and outputs	0dB	All switching configuration	Erased	Display	1, 2, 3, 4, 5, 6, 7, 8	Audio mode	AFV
IP address	192.168.1.39															
Mask	255.255.255.0															
Gateway	192.168.1.1															
Audio gain for all inputs and outputs	0dB															
All switching configuration	Erased															
Display	1, 2, 3, 4, 5, 6, 7, 8															
Audio mode	AFV															
13	ETHERNET Connector	Connects to the PC or other Serial Controller through computer networking														
14	PROG Button	Push in for "Program" to upgrade to the latest Kramer firmware via RS-232, or release for "Normal" (the factory default)														
15	AUDIO OUTPUTS Terminal Block Connectors	Connect to the balanced stereo audio acceptors														
16	AUDIO INPUTS Terminal Block Connectors	Connect to the balanced stereo audio sources														

4.1 Using the IR Transmitter

You can use the **RC-IR3** IR transmitter to control the machine via the built-in IR receiver on the front panel or, instead, via an optional external IR receiver³. The external IR receiver can be located up to 15 meters away from the machine. This

1 Can be used instead of the front panel (built-in) IR receiver to remotely control the machine (see [Section 4.1](#))

2 The ground connection is sometimes connected to the shield of the RS-485 cable. In most applications, the ground is not connected

3 Model: C-A35M/IRR-50

distance can be extended to up to 60 meters when used with three extension cables¹. Connect the external IR receiver to the REMOTE IR 3.5mm connector.

5 Installing the VP-885 in a Rack

This section describes what to do before installing in a rack and how to rack mount the **VP-885**.

Before Installing in a Rack

Before installing in a rack, be sure that the environment is within the recommended range:

Operating temperature range	+5° to +45° C (41° to 113° F)
Operating humidity range	10 to 90% RHL, non-condensing
Storage temperature range	-20° to +70° C (-4° to 158° F)
Storage humidity range	5 to 95% RHL, non-condensing



CAUTION!

When installing on a 19" rack, avoid hazards by taking care that:

1. It is located within the recommended environmental conditions, as the operating ambient temperature of a closed or multi unit rack assembly may exceed the room ambient temperature.
2. Once rack mounted, enough air will still flow around the machine.
3. The machine is placed straight in the correct horizontal position.
4. You do not overload the circuit(s). When connecting the machine to the supply circuit, overloading the circuits might have a detrimental effect on overcurrent protection and supply wiring. Refer to the appropriate nameplate ratings for information. For example, for fuse replacement, see the value printed on the product label.
5. The machine is earthed (grounded) in a reliable way and is connected only to an electricity socket with grounding. Pay particular attention to situations where electricity is supplied indirectly (when the power cord is not plugged directly into the socket in the wall), for example, when using an extension cable or a power strip, and that you use only the power cord that is supplied with the machine.

How to Rack Mount

To rack-mount a machine:

1. Attach both ear brackets to the machine. To do so, remove the screws from each side of the machine (5 on each side), and replace those screws through the ear brackets.

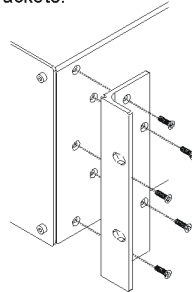

2. Place the ears of the machine against the rack rails, and insert the proper screws (not provided) through each of the four holes in the rack ears.

Note:

- In some models, the front panel may feature built-in rack ears
- Detachable rack ears can be removed for desktop use
- Always mount the machine in the rack before you attach any cables or connect the machine to the power
- If you are using a Kramer rack adapter kit (for a machine that is not 19"), see the Rack Adapters user manual for installation instructions available from: <http://www.kramerelectronics.com>

6 Connecting the VP-885

This section describes how to:

- Connect audio inputs/outputs (see [Section 6.1](#))
- Connect to the **VP-885** via RS-232 (see [Section 6.2](#))
- Connect to the **VP-885** via RS-485 (see [Section 6.3](#))
- Connect to the **VP-885** via the Ethernet port and configure the Ethernet port (see [Section 6.4](#))
- Set the DIP-switches (see [Section 6.5](#))

To connect¹ the **VP-885** to external devices as illustrated in the example² in [Figure 3](#):

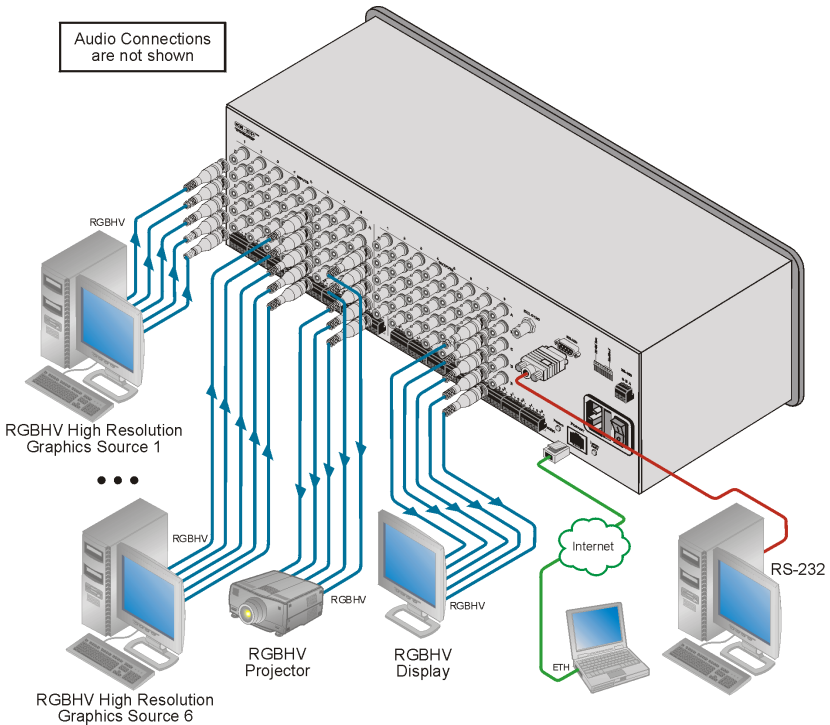

Figure 3: Connecting the VP-885

¹ You do not need to connect all inputs and outputs

² Switch OFF the power on each device before connecting it to your **VP-885**. After connecting your **VP-885**, switch on its power and then switch on the power on each device. DO NOT push in the rear panel Flash Program "PROG" button, it is only used for upgrading to the latest Kramer firmware

1. Connect up to 8 video sources¹ to the BNC INPUT connectors².
2. Connect up to 8 balanced stereo audio sources to the AUDIO INPUT terminal blocks (see [Section 6.1](#)).
3. Connect up to 8 video acceptors to the BNC OUT connectors².
4. Connect up to 8 balanced/unbalanced stereo audio acceptors to the OUTPUT terminal blocks.
5. If required, connect a PC and/or controller to the:
 - RS-232 port (see [Section 8.1](#))
 - RS-485 port (see [Section 8.2](#))
 - Ethernet port (see [Section 8.3](#))
6. Connect the power cord³ (not shown in [Figure 3](#)).

6.1 Connecting a Balanced/Unbalanced Stereo Audio Input/Output

This section describes how to wire:

- A balanced stereo audio input/output connection (see [Figure 4](#))
- An unbalanced stereo audio input (see [Figure 5](#))
- An unbalanced source to a balanced input (see [Figure 6](#))

[Figure 4](#) illustrates how to wire a balanced input/output connection.

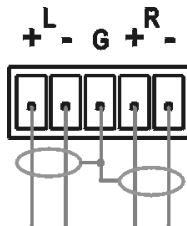

Figure 4: Wiring a Balanced Stereo Audio Input/Output

[Figure 5](#) illustrates how to wire an unbalanced acceptor to the balanced output of the unit.

¹ All signal connections using more than one cable to interconnect between the devices should be of equal length

² 5 BNC connectors per source/acceptor

³ We recommend that you use only the power cord that is supplied with this machine

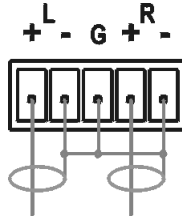

Figure 5: Wiring an Unbalanced Stereo Audio Output

Figure 6 illustrates how to wire an unbalanced source to the balanced input.

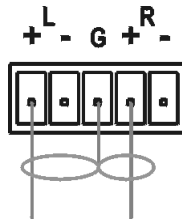

Figure 6: Wiring an Unbalanced Source to a Balanced Input

6.2 Connecting to the VP-885 via RS-232

You can connect to the VP-885 via an RS-232 connection using, for example, a PC. Note that a null-modem adapter/connection is not required.

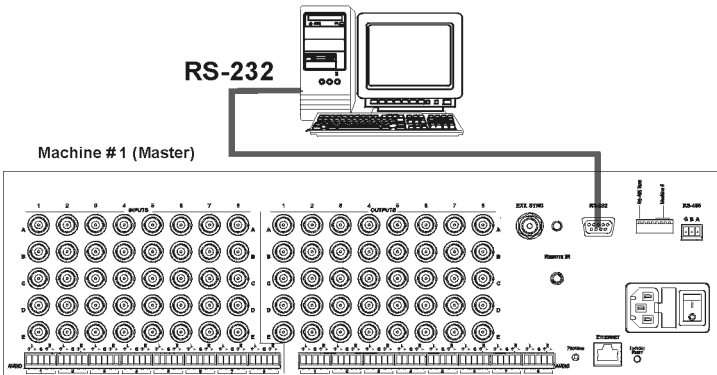

Figure 7: Connecting to the VP-885 via RS-232 using a PC

To connect to the VP-885 via RS-232 as illustrated in Figure 7:

- Connect the RS-232 9-pin D-sub rear panel port on the VP-885 unit via a 9-wire straight cable (pin 2 to pin 2, pin 3 to pin 3, pin 5 to pin 5) to the RS-232 9-pin D-sub port on your PC

6.3 Connecting to the VP-885 via RS-485

You can operate the **VP-885** via the RS-485 port from a distance of up to 1200m (3900ft) using any device equipped with an RS-485 port (for example, a PC). For successful communication, you must set the RS-485 machine number and bus termination.

To connect a device with an RS-485 port to the VP-885:

1. Connect the controller to the **VP-885** as follows:
 - Connect the A (+) pin on the RS-485 port of the PC to the A (+) pin on the RS-485 port on the rear panel of the **VP-885**
 - Connect the B (-) pin on the RS-485 port of the PC to the B (-) pin on the RS-485 port on the rear panel of the **VP-885**
 - Connect the G pin on the RS-485 port of the PC to the G pin on the RS-485 port on the rear panel of the **VP-88K**
2. Set the **VP-885** unit to any Machine number between 2 and 16 (see [Section 6.5](#)).
3. Terminate the RS-485 line on both the **VP-885** (see [Section 6.5](#)) and on the controller.

6.4 Connecting to the VP-885 via Ethernet

You can connect to the **VP-885** via Ethernet using either of the following methods:

- Direct connection to the PC using a crossover cable (see [Section 6.4.1](#))
- Connection via a network hub, switch, or router, using a straight-through cable as shown in [Figure 8](#) (see [Section 6.4.2](#))

Note: The following instructions are valid only if your PC uses a fixed IP address. If your PC receives an IP address from a DHCP server, consult with your IT department regarding setting the IP address.

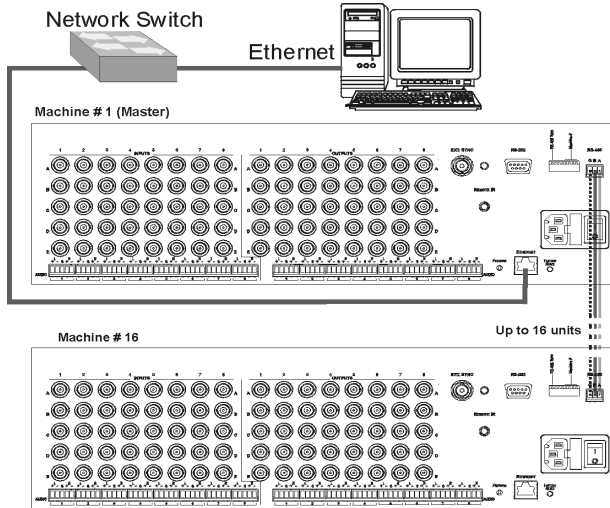

Figure 8: Connecting to the VP-885 via Ethernet

6.4.1 Connecting Directly via the Ethernet Port

You can connect the Ethernet port of the **VP-885** to the Ethernet port on your PC via a crossover cable with RJ-45 connectors.

This type of connection is recommended for identification of the factory default IP Address of the VP-885 during the initial configuration

To connect the VP-885 directly to a PC using a crossover cable:

1. Using a crossover cable, connect the **VP-885** to the PC via the Ethernet port on both units.
2. On the PC, click **Start > Control Panel**.
3. Double-click **Network Connections**.
4. Right-click, and from the menu select **Properties**.
The **Local Area Connection Properties** window appears.
5. Select **Internet Protocol (TCP/IP)** (see [Figure 9](#)).

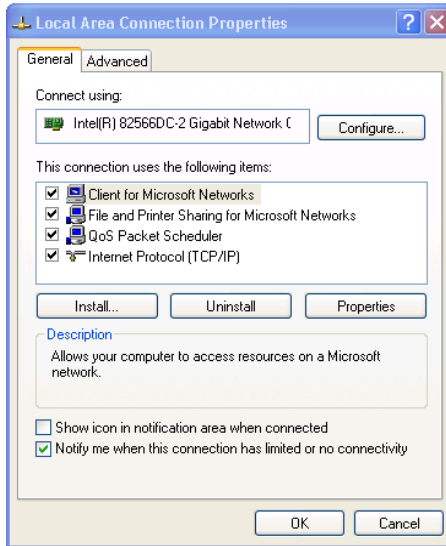

Figure 9: Local Area Connection Properties Window

6. Click the **Properties** button.
7. Select **Use the following IP address**, and fill in the details as shown in [Figure 10](#).

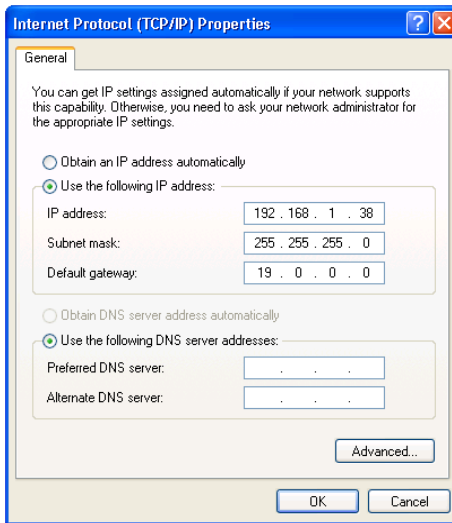

Figure 10: Internet Protocol (TCP/IP) Properties Window

8. Click **OK**.

6.4.2 Connecting via a Network Hub, Switch, or Router

You can connect the Ethernet port of the **VP-885** to the Ethernet port on a network hub, switch, or router, via a straight-through cable with RJ-45 connectors. The **VP-885** Ethernet port has to be configured to be compatible with your network (see [Section 6.4.3](#)).

6.4.3 Configuring the Ethernet Port on the VP-885

The **P3K Ethernet Configuration** software¹ is used to configure the Ethernet port of the **VP-885**. The software must be downloaded to your PC, the files extracted to a folder, and the software installed. Once the software has been installed, you can configure the Ethernet port on the **VP-885**.

To configure the VP-885 Ethernet port:

1. Click **Start > All Programs > Kramer > P3K Wizard**
The **P3K Wizard** window appears.
2. Click **Connect**.
The **Connect** window appears.

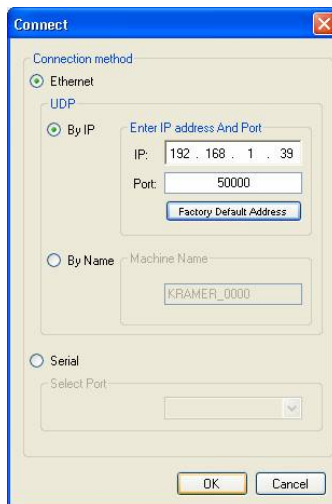

Figure 11: Connect Window

3. Select one of the following methods to connect to the Ethernet port of the **VP-885**:
 - Ethernet, if you are connected via an Ethernet cable. Enter the IP

¹ Available from <http://www.kramerelectronics.com>

address¹ or the machine name

The default IP address is 192.168.1.39 and the default name for the unit is KRAMER_XXXX²

- Serial, if you are connected via a serial port. Select the COM port from the Select Port drop-down list.
4. Click **OK**.
The **Device Properties** window appears.

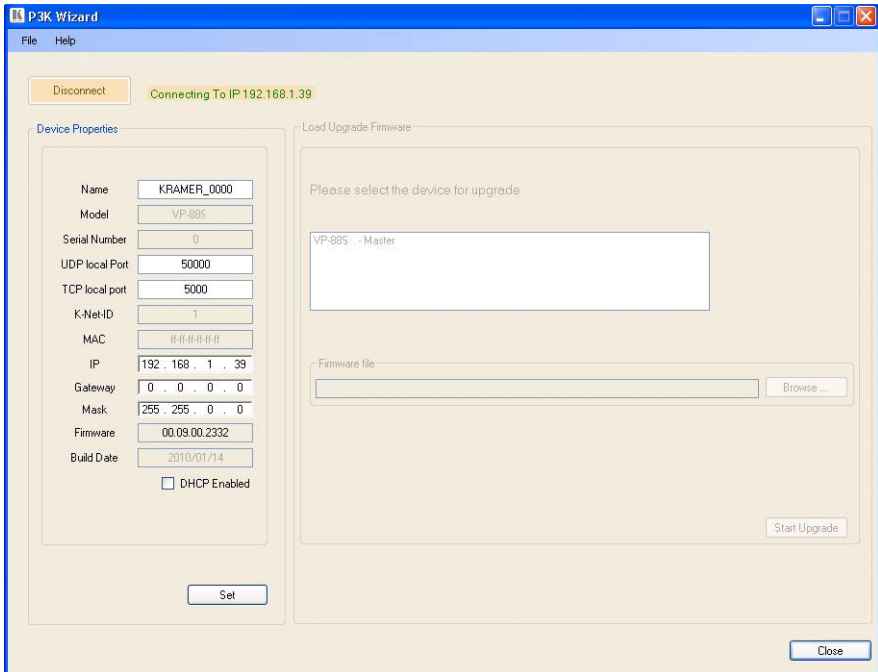

Figure 12: Device Properties Window

5. Make the required changes.
6. Click **Set** to save changes, or click **Close** to exit without saving the changes.

¹ The default IP address is 192.168.1.39

² The four digits are the last four digits of the machine's serial number.

6.5 Setting the VP-885 DIP-switches

This section describes the **VP-885** DIP-switch settings that configure RS-485 bus termination and the **VP-885** machine number.

[Figure 13](#) illustrates the factory default DIP-switch positions.

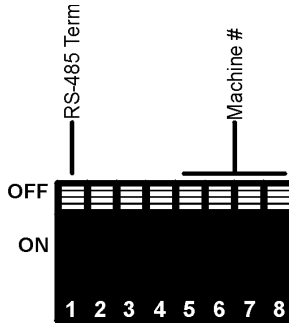

Figure 13: VP-885 DIP-switches

Table 4: DIP-switch Settings

#	DIP-switch Number	Function
1	1	RS-485 Termination
2	2, 3, 4	Not used
3	5, 6, 7, 8	Machine number (see Table 5)

DIP-switch 1 determines the RS-485 bus termination for the **VP-885**.

DIP-switches 2, 3, and 4 are not used.

DIP-switches 5, 6, 7, and 8 determine the machine number of the **VP-885**. When several **VP-885** units are connected, the machine number determines the unique identity of the **VP-885** in the sequence (see [Section 6.5](#)).

- When using a stand-alone VP-885 unit, set the machine number to 1 (factory default)
- When connecting more than one **VP-885**, set the first machine (only when connected via RS-232) to machine number 1. The other **VP-885** units must each be set to a unique machine number between 2 and 16.

Table 5: Machine Number DIP-switch Settings

Machine Number	DIP-switch				Machine Number	DIP-switch			
	5	6	7	8		5	6	7	8
1 (Master, factory default)	OFF	OFF	OFF	OFF	9 (Slave)	ON	OFF	OFF	OFF
2 (Slave)	OFF	OFF	OFF	ON	10 (Slave)	ON	OFF	OFF	ON
3 (Slave)	OFF	OFF	ON	OFF	11 (Slave)	ON	OFF	ON	OFF

Machine Number	DIP-switch			
	5	6	7	8
4 (Slave)	OFF	OFF	ON	ON
5 (Slave)	OFF	ON	OFF	OFF
6 (Slave)	OFF	ON	OFF	ON
7 (Slave)	OFF	ON	ON	OFF
8 (Slave)	OFF	ON	ON	ON

Machine Number	DIP-switch			
	5	6	7	8
12 (Slave)	ON	OFF	ON	ON
13 (Slave)	ON	ON	OFF	OFF
14 (Slave)	ON	ON	OFF	ON
15 (Slave)	ON	ON	ON	OFF
16 (Slave)	ON	ON	ON	ON

7 Operating the VP-885

You can operate the **VP-885** via any of the following methods:

- Front panel buttons
- RS-232
- RS-485 serial commands transmitted by a touch screen system, PC, or other serial controller
- Ethernet
- The Kramer **RC-IR3** Infra-Red Remote Control Transmitter

7.1 Displaying the Configuration of the VP-885

For five seconds after being switched on, the model and software version is displayed (see [Section 7.4.1](#)).

After the first five seconds, the 7-segment display¹ indicates which audio² or video³ input is switched to which output (see [Section 7.4.2](#)).

7.2 Switching Outputs to Inputs

To switch a video/audio input to an output:

- Press the desired OUTPUT button, followed by the desired INPUT button.

To connect a video/audio input to all outputs:

- Press the ALL button followed by the INPUT button corresponding to the input that is to be routed to all the outputs

To disconnect a video/audio input from a specific output:

- Press the desired OUTPUT button followed by the OFF button.

¹ Item 6 in [Table 2](#)

² When the Audio button lights, that is, when the audio breakaway mode is selected

³ When the Video button lights, that is, when the video breakaway mode is selected

To disconnect all outputs:

- Press the ALL button, followed by the OFF button

7.3 Confirming Settings

You can choose to work in the At Once or the Confirm mode. When the **VP-885** operates in the At Once mode, pressing an output-input combination implements the action immediately. In the Confirm mode, the TAKE button must be pressed to activate the switch.

The At Once Mode

In the At Once mode, execution is immediate and actions require no user confirmation. However, no protection is offered against changing an action in error.

The Confirm Mode

In the Confirm mode:

- You can enter several actions and then confirm them by pressing the TAKE button to simultaneously activate the multiple switches
- Every action requires user confirmation which protects against erroneous switching
- Execution is delayed¹ until the user confirms the action

7.3.1 Toggling between At Once and Confirm Modes

To toggle between the At Once and Confirm modes:

1. Press the TAKE button to toggle from the At Once mode² to the Confirm mode³.
Actions now require user confirmation and the TAKE button lights.
2. Press the TAKE button to toggle from the Confirm mode back to the At Once mode.
Actions no longer require user confirmation and the TAKE button no longer lights.

7.3.2 Confirming a Switching Action

To confirm a switching action (in the Confirm mode):

1. Press an output-input combination.
The corresponding input number that is displayed in the STATUS 7-segment display flashes. The TAKE button also flashes.

¹ If the TAKE button is not pressed within one minute, the action is aborted

² The TAKE button does not light

³ The TAKE button lights

2. Press the flashing TAKE button to confirm the action.
The corresponding input number that is displayed in the STATUS 7-segment display no longer flashes. The TAKE button lights.

To confirm several actions (in the Confirm mode):

1. Press each OUTPUT-INPUT combination in sequence.
The corresponding input numbers that are displayed in the STATUS 7-segment display flash. The TAKE button also flashes.
2. Press the flashing TAKE button to confirm all the actions.
The TAKE button lights and the corresponding input numbers that are displayed in the STATUS 7-segment display no longer flash.

7.4 Defining the 7-Segment Status Display Information

The **VP-885** has three display modes:

- Immediately after the power is turned on (see [Section 7.4.1](#))
- During normal operation (see [Section 7.4.2](#))
- During Audio Gain Level Setting (see [Section 7.4.3](#))

7.4.1 Status Display Immediately After Power is Turned On

Immediately after the unit is turned on, the status display shows:

1. The firmware version (major, minor, and revision) for the first five seconds (see [Figure 14](#))

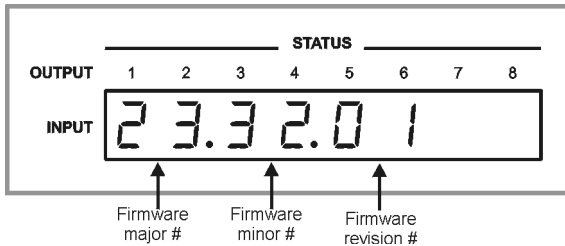

Figure 14: Status Display Immediately After Turn On

2. The firmware build number and machine number for the following five seconds (see [Figure 15](#)).

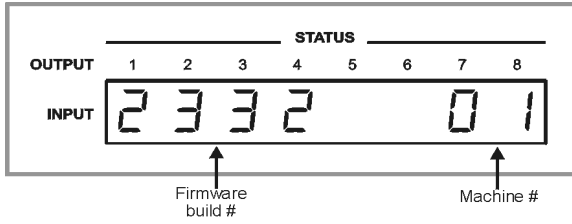

Figure 15: Status Display 5 Seconds After Turn On

7.4.2 Status Display During Normal Operation

During normal operation, the STATUS display shows which inputs are switched to which outputs (see [Figure 16](#)).

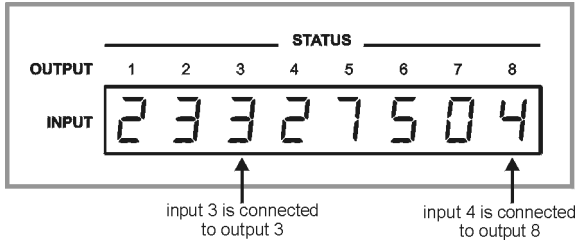

Figure 16: Status Display During Normal Operation

In the VIDEO mode, the display shows the video signal configuration. In the AUDIO mode, the display shows the audio signal configuration. In the AFV mode (see [Section 7.5.1](#)), the display shows both signal configurations.

7.4.3 Status Display During Audio Gain Level Setting

During audio gain level setting, the Status display indicates:

- Whether an INPUT or OUTPUT is selected (in this example, OUTPUT)
- Which channel number is selected (in this example, 3)
- The current gain setting in 0.5dB increments (in this example, -4.5). The 0.5dB is indicated by the period following the 4.

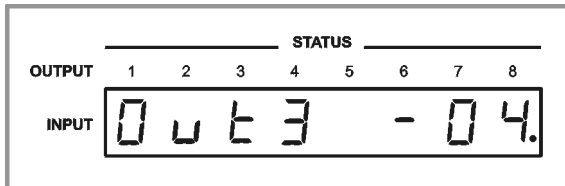

Figure 17: Status Display Showing OUTPUT 3, Gain -4.5

To set the audio gain levels, see [Section 7.7](#).

7.5 Choosing the Audio-Follow-Video or Breakaway Option

You can configure stereo audio signal switching in one of two ways:

- Audio-follow-video (AFV), in which all operations relate to both the video and the audio channels (see [Section 7.5.1](#))
- Breakaway, in which video and audio channels switch independently (see [Section 7.5.2](#))

7.5.1 Setting the Audio-Follow-Video Option

To set the Audio-follow-video (AFV) option, press the AFV button. One of the following occurs:

- If the AUDIO and VIDEO configurations are the same, then the AFV button lights. The audio follows the video
- If the AUDIO differs from the VIDEO, then the TAKE and the AUDIO buttons flash. Also, the audio outputs of the STATUS 7-segment display which change, flash¹. Press the TAKE button to confirm the modification. The audio follows the video

7.5.2 Setting the Breakaway Option

To set the Breakaway option:

- Press either the AUDIO (for audio control only) or the VIDEO (for video control only) button. One of the following occurs:
 - If the AUDIO button lights, switching operations relate to Audio
 - If the VIDEO button lights, switching operations relate to Video

The STATUS window displays audio or video settings according to your selection.

7.6 Storing/Recalling Input-Output Configurations

You can store and recall up to 16 input-output configurations (or setups) in non-volatile memory, using the OUTPUT (1-8) and OUTPUT (9-16) SELECTOR buttons (see [Figure 18](#)).

¹ This warns that you are about to modify the audio configuration for AFV operation

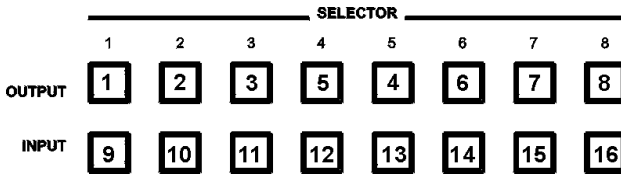

Figure 18: Configuration Button Numbering

7.6.1 Storing an Input-Output Configuration

To store the current status in memory:

1. Press the STO button.
The STO button flashes.
2. Press one of the INPUT/OUTPUT SELECTOR buttons from 1 to 8. This is the setup number in which the current status is stored.
The memory stores the data at that reference.

7.6.2 Recalling an Input-Output Configuration

To recall an input-output configuration, do the following:

1. Press the RCL button.
The RCL button flashes.
2. Press the appropriate INPUT/OUTPUT SELECTOR button (the INPUT SELECTOR button number corresponding to the setup number).
The memory recalls the stored data from that reference.

7.6.3 Deleting an Input-Output Configuration

To delete an input-output configuration:

1. Press the STO and RCL buttons simultaneously.
The STO and RCL buttons flash.
2. Press the appropriate INPUT SELECTOR button.
The specific input-output configuration is erased from the memory, leaving it empty and available¹.

7.7 Audio Input/Output Gain Control

The audio gain control is configured when the machine is in the AUDIO or AFV mode.

The default audio gain level for all inputs and outputs is 0dB. Each input or output can be set independently.

¹ Storing a new configuration over a previous configuration (without deleting it first) replaces the previous configuration

To set the gain level of an input or output:

1. To enter the audio gain setting mode, do either of the following:
 - Press either of the Audio Level buttons and press the required INPUT or OUTPUT SELECTOR button
 - Press the required INPUT or OUTPUT SELECTOR button.
If an OUTPUT is pressed, the display indicates which OUTPUT is selected by flashing the selected number. In this example, OUTPUT 8 is selected (see [Figure 19](#))

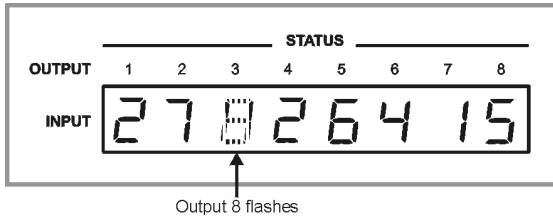

Figure 19: Status Display OUTPUT 8 Flashing

2. Press either the plus (+) button to increase, or the minus (-) button to decrease the current gain level setting.
The display changes to indicate (see [Figure 20](#)):
 - whether an INPUT or OUTPUT is selected (in this example, OUTPUT)
 - which channel number is selected (in this example, 8)
 - the current gain setting (in this example, -4.5)

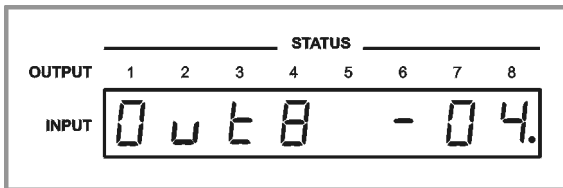

Figure 20: Status Display Showing OUTPUT 8, Gain -4.5

3. Press either the (+) button to increase or the minus (-) button to increase or decrease respectively the gain level setting.
The display changes accordingly.
4. Press either the Audio or Video button to exit the gain level setting mode.
If no button is pressed for 10 seconds, the **VP-885** automatically exits the gain level setting mode and the display reverts to normal operation.

The factory default audio gain is set to 0dB. An audio gain value of 0dB indicates that the output signal value is identical to the input signal value.

When increasing/ decreasing the audio gain, the output signal level is higher/lower than the input signal level.

Gain level values are relative since the audio input signal can be also adjusted independently of the output level adjustment.

7.8 Resetting the Unit

To reset the unit:

- Press and hold the Reset button on the rear panel while powering on the device.

The unit resets and a Status display self-test is performed (see [Section 7.4.1](#))

8 Controlling the VP-885

The **VP-885** can be controlled via any of the following:

- RS-232 (see [Section 8.1](#))
- RS-485 (see [Section 8.2](#))
- Ethernet (see [Section 8.3](#))

8.1 Controlling the VP-885 via RS-232

To control up to sixteen VP-885 units from a PC or serial controller via RS-232, as illustrated in [Figure 21](#):

1. Connect the video sources and acceptors, the appropriate audio sources and acceptors, and the power cord to each **VP-885**.
2. Connect the PC to the first **VP-885** via an RS-232 serial cable (see [Section 6.2](#))
3. Set the Machine number on the first **VP-885** to be Machine 1 (see [Section 6.5](#)).
4. Terminate the RS-485 line on both the first **VP-885** and on the last **VP-885** (see [Section 6.5](#)).
5. Set the Machine number on all **VP-885** units other than Machine 1 to a unique number¹ between 2 and 16 (see [Section 6.5](#)).
6. Connect the RS-485 port on the first **VP-885** to the RS-485 terminal block on the second **VP-885** unit as follows:
 - Connect the A (+) pin on the RS-485 rear terminal block of the first **VP-885** to the A (+) pin on the RS-485 rear panel terminal block on the second **VP-885**

¹ Set the first unit to Machine number 2, the second unit to Machine number 3, etc. up to 16

- Connect the B (-) pin on the RS-485 rear panel terminal block of the first **VP-885** to the B (-) pin on the RS-485 rear panel terminal block of the second **VP-885**
 - Connect the G pin on the RS-485 rear panel terminal block of the first **VP-885** to the G pin on the RS-485 rear panel terminal block of the second **VP-885**
7. Using the same wiring configuration as described in [Step 6](#), interconnect the RS-485 bus on the rest of the **VP-885** units. Up to sixteen **VP-885** units can be connected (see [Section 6.2](#)).

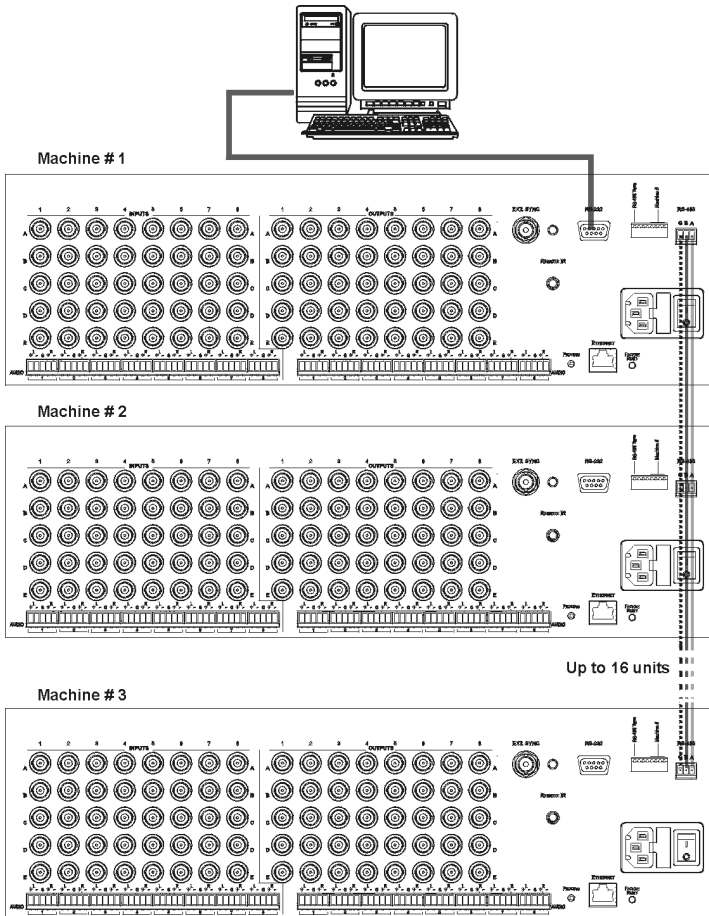

Figure 21: Control Configuration via RS-232

8.2 Controlling the VP-885 via RS-485

You can operate the **VP-885** via the RS-485 port from a distance of up to 1200m (3900ft) using a PC equipped with a card that provides an RS-485 port.

To connect a PC or controller to the RS-485 port on the unit:

1. Wire the RS-485 port on the **VP-885** to the RS-485 port on the controller as follows:
 - Connect the A (+) pin on the RS-485 port of the PC to the A (+) pin on the RS-485 port on the rear panel of the **VP-885**
 - Connect the B (-) pin on the RS-485 port of the PC to the B (-) pin on the RS-485 port on the rear panel of the **VP-885**
 - Connect the G pin on the RS-485 port of the PC to the G pin on the RS-485 port on the rear panel of the **VP-885**
2. Set the DIP-switches (see [Section 6.5](#)) so that the Machine number on the **VP-885** is any number between 2 and 16.
3. Terminate the RS-485 line on both the **VP-885** (set DIP-switch 1 to ON) and on the controller.

8.3 Controlling the VP-885 via Ethernet

The **VP-885** must be suitably configured before you can control it via Ethernet. Configuration instructions are provided in [Section 6.4.3](#).

To control the VP-885 via Ethernet:

1. Connect the Ethernet port on Machine number 1 (see [Section 6.4](#)) to the LAN port of your PC either:
 - via a network switch (as shown in [Figure 22](#)) using a straight-through cable
 - directly using a crossover cable
2. Connect the video sources and acceptors, the appropriate audio sources and acceptors, and the power cord to each **VP-885**.
3. Set the Machine number on the first **VP-885** to be Machine 1 (see [Section 6.5](#)).
4. Terminate the RS-485 line on both the first **VP-885** and on the last **VP-885** (see [Section 6.5](#)).
5. Set the Machine number on all **VP-885** units other than Machine 1 to a unique number¹ between 2 and 16 (see [Section 6.5](#)).

¹ Set the first unit to Machine number 2, the second unit to Machine number 3, and so on up to 16

6. Connect the RS-485 port on the first **VP-885** to the RS-485 terminal block on the second **VP-885** unit as follows:
 - Connect the A (+) pin on the RS-485 rear terminal block of the first **VP-885** to the A (+) pin on the RS-485 rear panel terminal block on the second **VP-885**
 - Connect the B (-) pin on the RS-485 rear panel terminal block of the first **VP-885** to the B (-) pin on the RS-485 rear panel terminal block of the second **VP-885**
 - Connect the G pin on the RS-485 rear panel terminal block of the first **VP-885** to the G pin on the RS-485 rear panel terminal block of the second **VP-885**
7. Using the same wiring configuration as described in [Step 6](#), interconnect the RS-485 bus on the rest of the **VP-885** units. Up to sixteen **VP-885** units can be connected (see [Section 6.2](#)).

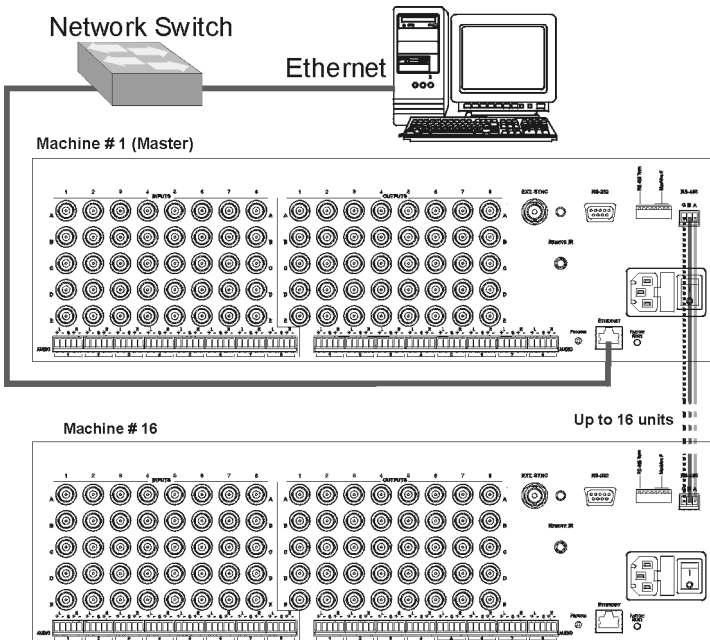

Figure 22: Controlling the VP-885 via Ethernet

9 Updating the Firmware

For instructions on upgrading the firmware, see the *Updating the Firmware Using the P3K Software* document.

The latest version of firmware and installation instructions can be downloaded from the Kramer Web site at www.kramerelectronics.com.

10 Connecting to the VP-885 via your Browser

Make sure that your PC is connected via a network to the **VP-885** and do the following:

1. Open your Internet browser.
2. Enter the unit's IP number (for the default IP address, see [Figure 23](#)) or name in the Address bar of your browser.
If you are using DHCP, you have to enter the name.



Figure 23: Entering the IP Number in the Address Bar

The Loading page appears.

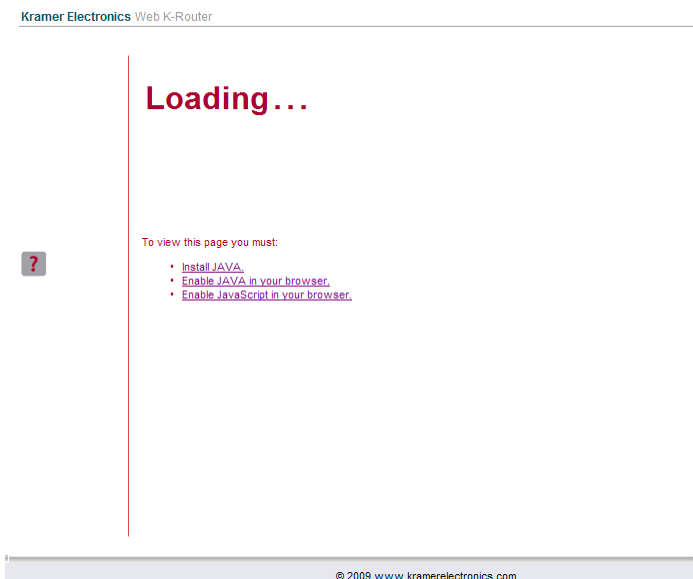

Figure 24: The Loading Page

The first time that you run the Kramer applet a security warning appears.



Figure 25: First Time Security Warning

3. Click **Run**.

The main switching control page is displayed which shows a graphical representation of the front panel (see [Figure 26](#)).

There are three remote operation Web pages:

- Main switching matrix (see [Section 10.1](#))
- Audio gain control (see [Section 10.2](#))
- Configuration (see [Section 10.3](#))

Select a page by clicking on the relevant link on the left hand side of the window.

10.1 The Main Switching Matrix Page

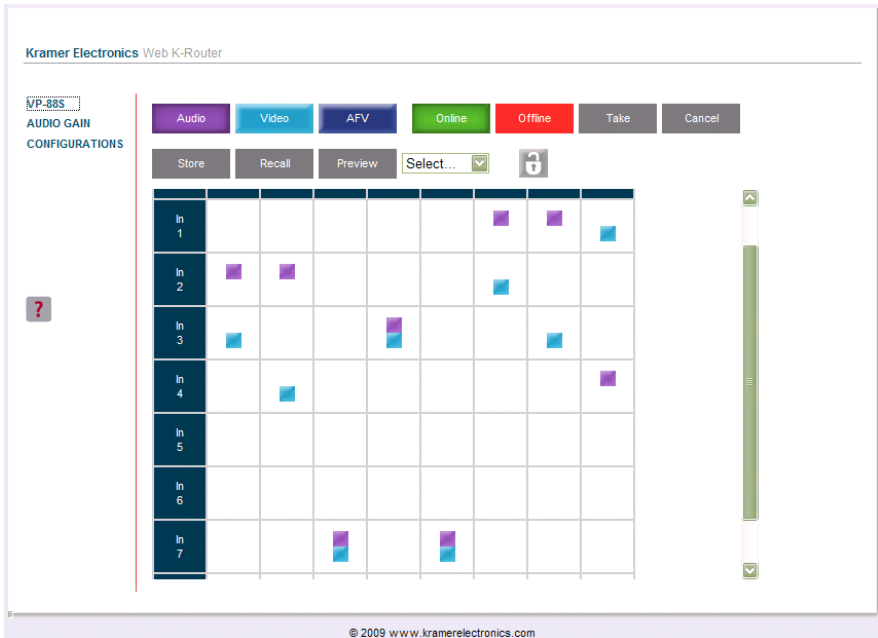

Figure 26: Main Switching Matrix Page

The main switching matrix page allows you to:

- Switch any audio/video input to any/all outputs independently (see [Section 10.1.1](#))
- Set the audio to operate in AFV (Audio Follow Video) mode (see [Section 10.1.2](#))
- Operate the unit in the Offline mode (see [Section 10.1.3](#))
- Use presets to store and recall switching configurations (see [Section 10.1.4](#))
- Lock or unlock the unit's front panel buttons (see [Section 10.1.5](#))

10.1.1 Switching an Input to an Output

To switch an input to an output, for example, video input 1 to video output 4:

1. Click the blue **Video** button.
The button outline becomes dark. Actions now relate to video channels.
2. Click the required point within the switching matrix grid (In 1, Out 4).

	Out 1	Out 2	Out 3	Out 4	Out 5
In 1				1 > 4	
In 2					

Figure 27: Selecting a Switching Point on the Matrix

A blue video icon  appears indicating that the video channel is switched to In 1 and Out 4.

	Out 1	Out 2	Out 3	Out 4	Out 5
In 1				▶	
In 2					

Figure 28: Switching an Input to an Output

- Repeat the above steps for each video and audio (clicking the purple **Audio** button) channel that you want to switch.

10.1.2 Setting the AFV Mode

Audio channel In 1 is currently switched to Out 4.

To set the AFV mode:

- Click the **AFV** button.
The following warning appears.

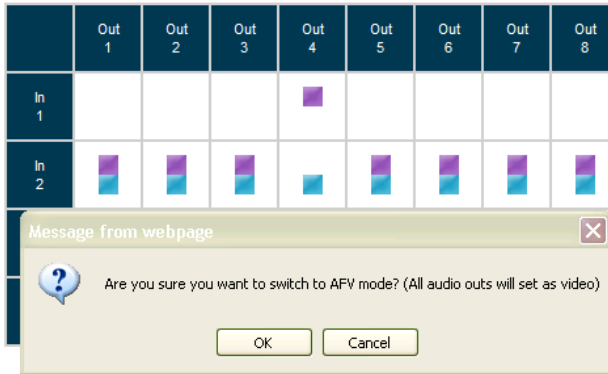

Figure 29: AFV Mode Warning

- Click **OK**.
The **AFV** button outline becomes dark.
All audio channels are switched according to the corresponding video channels. In this example, audio channel In 2 is now switched to Out 4.

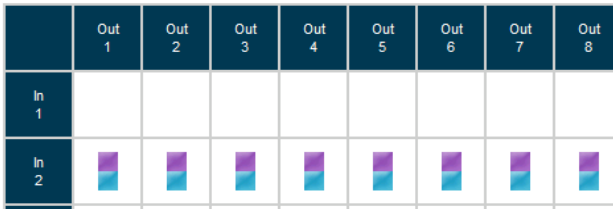

Figure 30: AFV Mode Audio Channels Switched

All configuration changes now switch audio and video simultaneously.

10.1.3 Operating in the Offline Mode

By default, the unit operates in the At-Once mode, meaning that any switching changes take effect immediately. In the Offline mode, changes only take effect when you press the **Take** button.

To operate in the Offline mode:

- Click the red **Offline** button.
The button outline becomes dark.
- Click the required point in the switching matrix grid (In 1, Out 5).
The audio/video indicator icon outline (in this example, audio) appears, and the **Take** and **Cancel** buttons change from gray to dark blue.

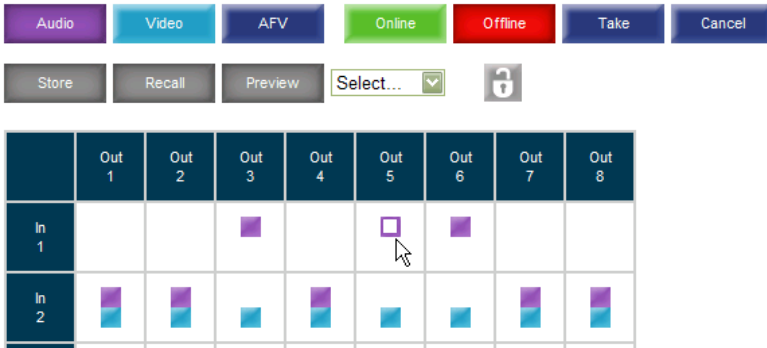

Figure 31: Switching Audio in the Offline Mode

3. If required, repeat Step 2 for several audio/video channels.
4. Click either **Take** to accept the change or **Cancel**.
5. Click the **Online** button to exit the Offline mode.
If you have made any changes since clicking the **Take** button, the exiting Offline warning appears.

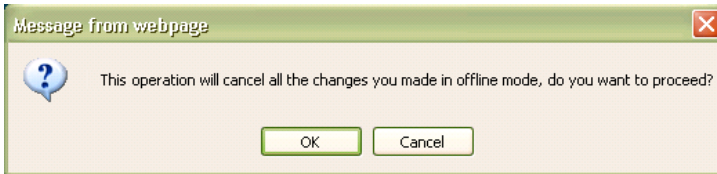

Figure 32: Exiting Offline Warning

10.1.4 Storing and Recalling Setups

You can store switching configurations in presets and recall them at any time.

To store a switching configuration:

1. From the Preset drop-down list, select a preset (in this example, Preset 07).
Presets that contain a configuration are displayed with a blue background; presets with no configuration have a white background.
When you select a preset, the **Store** button changes from gray to dark blue.

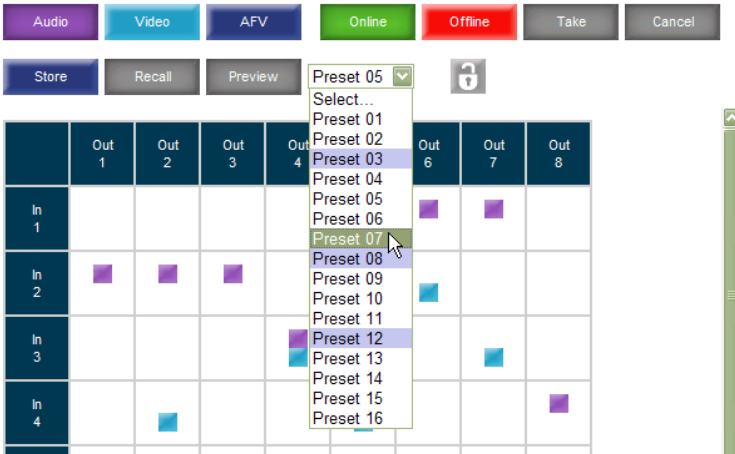

Figure 33: Selecting Preset 07

2. Click **Store**.
A confirmation message appears.
3. Click **OK**.
The configuration is stored in Preset 07.

To recall a setup:

1. From the Preset drop-down list, select a preset (in this example, Preset 03).
Presets that contain a configuration are displayed with a blue background; presets with no configuration have a white background.
When you select a preset that contains a configuration, the **Recall** button changes from grey to dark blue.

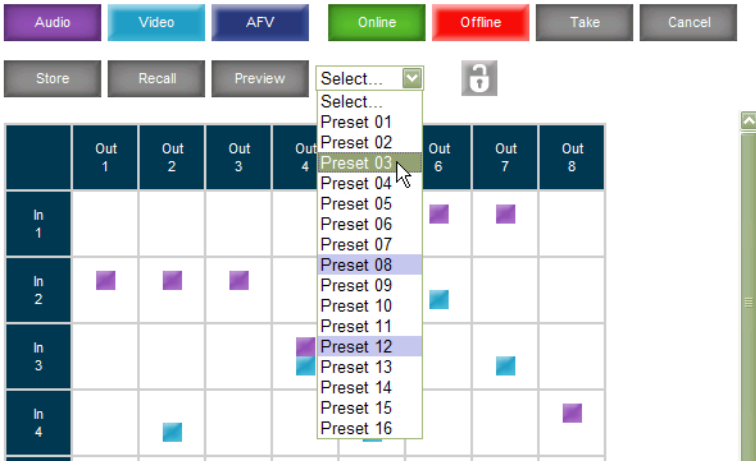

Figure 34: Selecting Preset 03

2. Click **Recall**.
A confirmation message appears.
3. Click **OK**.
The configuration from Preset 03 is loaded.

Note: You can also recall a preset in the Offline mode (see [Figure 36](#)) and make it active when you press the **Take** button (see [Section 10.1.3](#)).

















	Out 1	Out 2	Out 3	Out 4	Out 5	Out 6	Out 7	Out 8	
In 1	 						 		
In 2									
In 3									
In 4									

Figure 35: Recalling a Preset in Offline Mode

10.1.5 Locking the Front Panel Buttons

You can lock the front panel buttons to prevent tampering.

To lock the front panel buttons:

- Click the padlock icon 

Note: Locking the front panel buttons does not disable remote operation of the unit via Ethernet, RS-232 or RS-485.

10.2 Audio Input Gain Control Page

The Audio Gain page lets you set the gain for each of the input channels independently.

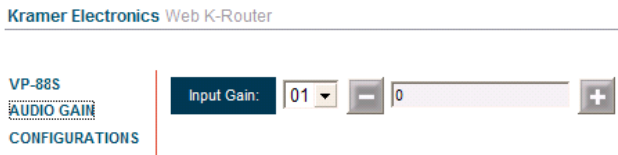

Figure 36: Audio Gain Control Page

To change the audio gain (in this example, input gain for channel 2):

1. From the Input Gain drop-down list, click 02.

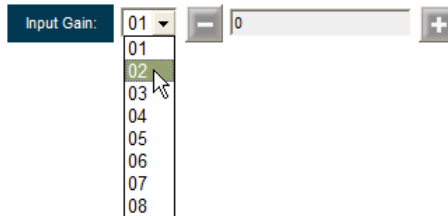

Figure 37: Selecting Audio Input Gain for Channel 2

2. Click the – or + button to decrease or increase the gain. Hold the – or + button down to cycle through the values.

Note: Each click increments/decrements the value by 0.5. To change the gain by a whole number, you must click the +/- button twice.

10.3 The Configuration Page

The Configuration page lets you edit the IP-related settings and only view the others. Editable fields have a white background.

The screenshot shows the configuration page for a VP-885 device. On the left, there is a navigation menu with 'VP-885', 'AUDIO GAIN', and 'CONFIGURATIONS' (which is highlighted with a dashed border). Below the menu is a red question mark icon. The main configuration area contains the following fields:

Name:	KRAMER_0000
Model:	VP-885
Serial Number:	0
Firmware version:	00.09.00.2983
MAC Address:	00-20-4a-86-27-a1
IP Address:	192.168.001.039
DHCP:	<input type="checkbox"/>
Gateway:	000.000.000.000
Subnet Mask:	255.255.000.000

At the bottom of the form are two buttons: a dark blue 'Submit' button and a red 'Cancel' button.

Figure 38: Configuration Page

The following IP-related settings can be edited:

- Machine name
- Fixed IP Address/DHCP
- Gateway
- Subnet Mask

The following fields can be viewed:

- Model
- Serial Number
- Firmware Version
- MAC Address

To edit the IP-related settings:

1. Edit the required field.
2. Click **Submit**.
The Network Settings confirmation message appears.
3. Click **OK**.
A message appears showing that the settings have been successfully changed.
4. If the IP address was changed or you selected DHCP, reload the Web page using the new name or IP address.

11 Communication Parameters

[Table 6](#) lists the communication parameters as used in Kramer Electronics products.

Table 6: Communication Parameters

RS-232			
Protocol 2000		Protocol 3000 (Default)	
Baud Rate:	9600	Baud Rate:	115,200
Data Bits:	8	Data Bits:	8
Stop Bits:	1	Stop Bits:	1
Parity:	None	Parity:	None
Command Format:	HEX	Command Format:	ASCII
Example (Output 1 to Input 1):	0x01, 0x81, 0x81, 0x81	Example (Output 1 to Input 1):	#AV 1>1<CR>
Switching Protocol			
P2000 -> P3000		P3000 -> P2000	
Command:	0x38, 0x80, 0x83, 0x81	Command:	#P2000<CR>
Front Panel:	Press and hold Output 1 and Output 3 simultaneously	Front Panel:	Press and hold Output 1 and Output 2 simultaneously
Ethernet			
Default Settings		Reset Settings	
IP Address: 192.168.1.39	Power cycle the unit while holding in the Factory Reset button, located on the rear panel of the unit.		
Subnet mask: 255.255.255.0			
Gateway: 192.168.1.1			
TCP Port #: 5000			
UDP Port #: 50000			

12 Technical Specifications

[Table 7](#) lists the technical specifications for the **VP-885**.

Table 7: Technical Specifications¹ for the VP-885

INPUTS:	5x8 composite video 0.7Vpp/75 Ω and S/PDIF digital audio or sVideo 0.7Vpp/75 Ω (Y), 0.7Vpp/75Ω (C); and component video 0.7Vpp/75Ω on BNC connectors 8 balanced stereo audio, 2.2V/10kΩ on detachable terminal blocks 1 External Sync ² 1Vpp on a BNC connector	
OUTPUTS:	5x8 composite video 0.7Vpp/75 Ω and S/PDIF digital audio or sVideo 0.7Vpp/75 Ω (Y), 0.7Vpp/75Ω (C); and component video 0.7Vpp/75Ω on BNC connectors 8 balanced stereo audio, 2.2V/150 Ω on detachable terminal blocks	
MAX. OUTPUT LEVEL:	VIDEO: 2.4Vpp (RGB)	AUDIO: 15Vpp @max gain
BANDWIDTH (-3dB):	VIDEO: 350MHz, Fully Loaded	AUDIO: 22kHz @-3dB
S/N RATIO:	VIDEO: 74dB	AUDIO: 81dB @1kHz
CROSSTALK (all hostile):	VIDEO: -47dB @ 5MHz	AUDIO: <-57dB @20kHz
DIFF. GAIN	0.05	
DIFF. PHASE	0.05	
CONTROLS:	Manual, RS-232, RS-485 or ETHERNET	
AUDIO THD + NOISE:	0.089%@1kHz	
POWER SOURCE:	100 - 240VAC, 50/60Hz, 23VA	
DIMENSIONS:	48.26cm x 17.78cm x 3U (19" x 7" x 3U)	
WEIGHT:	5.5kg (12.2lbs) approx.	
ACCESSORIES:	Power cord, Windows®-based Kramer control software	
OPTIONS:	External remote IR receiver cable ³	

¹ Specifications are subject to change without notice

² The sync input cannot accept video signal level

³ P/N: C-A35M/IRR-50

13 Tables of ASCII Codes for Serial Communication (Protocol 3000)

[Table 8](#) and [Table 9](#) list the ASCII codes that switch an input to an output for a single **VP-885** machine. For more detailed information, see [Section 15.2](#).

Table 8: VP-885 Video Signal Codes

	OUT 1	OUT 2	OUT 3	OUT 4	OUT 5	OUT 6	OUT 7	OUT 8
IN 1	#V 1>1 CR	#V 1>2 CR	#V 1>3 CR	#V 1>4 CR	#V 1>5 CR	#V 1>6 CR	#V 1>7 CR	#V 1>8 CR
IN 2	#V 2>1 CR	#V 2>2 CR	#V 2>3 CR	#V 2>4 CR	#V 2>5 CR	#V 2>6 CR	#V 2>7 CR	#V 2>8 CR
IN 3	#V 3>1 CR	#V 3>2 CR	#V 3>3 CR	#V 3>4 CR	#V 3>5 CR	#V 3>6 CR	#V 3>7 CR	#V 3>8 CR
IN 4	#V 4>1 CR	#V 4>2 CR	#V 4>3 CR	#V 4>4 CR	#V 4>5 CR	#V 4>6 CR	#V 4>7 CR	#V 4>8 CR
IN 5	#V 5>1 CR	#V 5>2 CR	#V 5>3 CR	#V 5>4 CR	#V 5>5 CR	#V 5>6 CR	#V 5>7 CR	#V 5>8 CR
IN 6	#V 6>1 CR	#V 6>2 CR	#V 6>3 CR	#V 6>4 CR	#V 6>5 CR	#V 6>6 CR	#V 6>7 CR	#V 6>8 CR
IN 7	#V 7>1 CR	#V 7>2 CR	#V 7>3 CR	#V 7>4 CR	#V 7>5 CR	#V 7>6 CR	#V 7>7 CR	#V 7>8 CR
IN 8	#V 8>1 CR	#V 8>2 CR	#V 8>3 CR	#V 8>4 CR	#V 8>5 CR	#V 8>6 CR	#V 8>7 CR	#V 8>8 CR

Table 9: VP-885 Audio Signal Codes

	OUT 1	OUT 2	OUT 3	OUT 4	OUT 5	OUT 6	OUT 7	OUT 8
IN 1	#A 1>1 CR	#A 1>2 CR	#A 1>3 CR	#A 1>4 CR	#A 1>5 CR	#A 1>6 CR	#A 1>7 CR	#A 1>8 CR
IN 2	#A 2>1 CR	#A 2>2 CR	#A 2>3 CR	#A 2>4 CR	#A 2>5 CR	#A 2>6 CR	#A 2>7 CR	#A 2>8 CR
IN 3	#A 3>1 CR	#A 3>2 CR	#A 3>3 CR	#A 3>4 CR	#A 3>5 CR	#A 3>6 CR	#A 3>7 CR	#A 3>8 CR
IN 4	#A 4>1 CR	#A 4>2 CR	#A 4>3 CR	#A 4>4 CR	#A 4>5 CR	#A 4>6 CR	#A 4>7 CR	#A 4>8 CR
IN 5	#A 5>1 CR	#A 5>2 CR	#A 5>3 CR	#A 5>4 CR	#A 5>5 CR	#A 5>6 CR	#A 5>7 CR	#A 5>8 CR
IN 6	#A 6>1 CR	#A 6>2 CR	#A 6>3 CR	#A 6>4 CR	#A 6>5 CR	#A 6>6 CR	#A 6>7 CR	#A 6>8 CR
IN 7	#A 7>1 CR	#A 7>2 CR	#A 7>3 CR	#A 7>4 CR	#A 7>5 CR	#A 7>6 CR	#A 7>7 CR	#A 7>8 CR
IN 8	#A 8>1 CR	#A 8>2 CR	#A 8>3 CR	#A 8>4 CR	#A 8>5 CR	#A 8>6 CR	#A 8>7 CR	#A 8>8 CR

[Table 10](#) lists the codes that set the audio input gain. For more detailed information, see [Section 15.2](#).

Table 10: VP-885 Audio Input Gain Codes

INPUT 1		INPUT 5		INPUT X*	LEVEL [REL]
#AUD-LVL 1,1, -100 CR	...	#AUD-LVL 1,5, -100 CR	...	#AUD-LVL 1,X, -100 CR	-100dB Mute
⋮		⋮		⋮	
#AUD-LVL 1,1, -50 CR	...	#AUD-LVL 1,5, -50 CR	...	#AUD-LVL 1,X, -50 CR	-50dB
⋮		⋮		⋮	
#AUD-LVL 1,1, 0 CR	...	#AUD-LVL 1,5, 0 CR	...	#AUD-LVL 1,X, 0 CR	0dB
⋮		⋮		⋮	
#AUD-LVL 1,1, 14 CR	...	#AUD-LVL 1,5, 14 CR	...	#AUD-LVL 1,X, 14 CR	+14dB (Max)

* Where X is the input number from 1 - 8. For example, for channel 7 and relative level -50dB, #AUD-LVL 1,7, -50**CR**

[Table 11](#) lists the codes that set the audio output gain. For more detailed information, see [Section 15.2](#).

Table 11: VP-885 Audio Output Gain Codes

OUTPUT 1		OUTPUT 5		OUTPUT X*	LEVEL [REL]
#AUD-LVL 2,1, -100CR	...	#AUD-LVL 2,5, -100CR	...	#AUD-LVL 2,X, -100CR	-100dB Mute
⋮		⋮		⋮	
#AUD-LVL 2,1, -50CR	...	#AUD-LVL 2,5, -50CR	...	#AUD-LVL 2,X, -50CR	-50dB
⋮		⋮		⋮	
#AUD-LVL 2,1, 0CR	...	#AUD-LVL 2,5, 0CR	...	#AUD-LVL 2,X, 0CR	0dB
⋮		⋮		⋮	
#AUD-LVL 2,1, 13CR	...	#AUD-LVL 2,5, 13CR	...	#AUD-LVL 2,X, 13CR	+13dB (Max)

* Where X is the output number from 1 - 8. For example, for channel 7 and relative level -50dB, #AUD-LVL 2,7, -50CR

14 Tables of Hex Codes for Serial Communication (Protocol 2000)

The hex codes listed in this section are used to set video channels for a single machine (set as Machine 1) connected via either RS-232 or Ethernet. Similar hex codes are used when the VP-885 is connected via RS-485 and the machine is set to number 2.

[Table 12](#) lists the Hex codes that switch video channels.

Table 12: VP-885 Hex Codes that Switch Video Channels

Switching Video Channels								
	OUT 1	OUT 2	OUT 3	OUT 4	OUT 5	OUT 6	OUT 7	OUT 8
IN 1	01 81 81 81	01 81 82 81	01 81 83 81	01 81 84 81	01 81 85 81	01 81 86 81	01 81 87 81	01 81 88 81
IN 2	01 82 81 81	01 82 82 81	01 82 83 81	01 82 84 81	01 82 85 81	01 82 86 81	01 82 87 81	01 82 88 81
IN 3	01 83 81 81	01 83 82 81	01 83 83 81	01 83 84 81	01 83 85 81	01 83 86 81	01 83 87 81	01 83 88 81
IN 4	01 84 81 81	01 84 82 81	01 84 83 81	01 83 84 81	01 84 85 81	01 84 86 81	01 84 87 81	01 84 88 81
IN 5	01 85 81 81	01 85 82 81	01 85 83 81	01 85 84 81	01 85 85 81	01 85 86 81	01 85 87 81	01 85 88 81
IN 6	01 86 81 81	01 86 82 81	01 86 83 81	01 86 84 81	01 86 85 81	01 86 86 81	01 86 87 81	01 86 88 81
IN 7	01 87 81 81	01 87 82 81	01 87 83 81	01 87 84 81	01 87 85 81	01 87 86 81	01 87 87 81	01 87 88 81
IN 8	01 88 81 81	01 88 82 81	01 88 83 81	01 88 84 81	01 88 85 81	01 88 86 81	01 88 87 81	01 88 88 81

[Table 13](#) lists the Hex codes that switch audio channels.

Table 13: VP-885 Hex Codes that Switch Audio Channels

Switching Audio Channels								
	OUT 1	OUT 2	OUT 3	OUT 4	OUT 5	OUT 6	OUT 7	OUT 8
IN 1	02 81 81 81	02 81 82 81	02 81 83 81	02 81 84 81	02 81 85 81	02 81 86 81	02 81 87 81	02 81 88 81
IN 2	02 82 81 81	02 82 82 81	02 82 83 81	02 82 84 81	02 82 85 81	02 82 86 81	02 82 87 81	02 82 88 81
IN 3	02 83 81 81	02 83 82 81	02 83 83 81	02 83 84 81	02 83 85 81	02 83 86 81	02 83 87 81	02 83 88 81
IN 4	02 84 81 81	02 84 82 81	02 84 83 81	02 83 84 81	02 84 85 81	02 84 86 81	02 84 87 81	02 84 88 81
IN 5	02 85 81 81	02 85 82 81	02 85 83 81	02 85 84 81	02 85 85 81	02 85 86 81	02 85 87 81	02 85 88 81
IN 6	02 86 81 81	02 86 82 81	02 86 83 81	02 86 84 81	02 86 85 81	02 86 86 81	02 86 87 81	02 86 88 81
IN 7	02 87 81 81	02 87 82 81	02 87 83 81	02 87 84 81	02 87 85 81	02 87 86 81	02 87 87 81	02 87 88 81
IN 8	02 88 81 81	02 88 82 81	02 88 83 81	02 88 84 81	02 88 85 81	02 88 86 81	02 88 87 81	02 88 88 81

[Table 14](#) lists the Hex codes that increase or decrease audio input gain.

Table 14: VP-885 Hex Codes that Increase/Decrease Audio Input Gain

	IN 1	IN 2	IN 3	IN 4	IN 5	IN 6	IN 7	IN 8
Increase	18 81 86 81	18 82 86 81	18 83 86 81	18 84 86 81	18 85 86 81	18 86 86 81	18 87 86 81	18 88 86 81
Decrease	18 81 87 81	18 82 87 81	18 83 87 81	18 84 87 81	18 85 87 81	18 86 87 81	18 87 87 81	18 88 87 81

Table 15 lists the Hex codes that set the audio input gain.

Before sending the any of the codes in Table 15, the command 2A 86 80 81 must be sent.

Table 15: VP-885 Hex Codes that Set the Audio Input Gain

IN 1	IN 2	IN 3	IN 4	IN 5	IN 6	IN 7	IN 8	LEVEL [REL]
16 81 80 81	16 82 80 81	16 83 80 81	16 84 80 81	16 85 80 81	16 86 80 81	16 87 80 81	16 88 80 81	Mute
⋮	⋮	⋮	⋮	⋮	⋮	⋮	⋮	
16 81 8D* 81	16 82 8D* 81	16 83 8D* 81	16 84 8D* 81	16 85 8D* 81	16 86 8D* 81	16 87 8D* 81	16 88 8D* 81	-100dB Mute
⋮	⋮	⋮	⋮	⋮	⋮	⋮	⋮	
16 81 BF 81	16 82 BF 81	16 83 BF 81	16 84 BF 81	16 85 BF 81	16 86 BF 81	16 87 BF 81	16 88 BF 81	-50dB
⋮	⋮	⋮	⋮	⋮	⋮	⋮	⋮	
16 81 F1 81	16 82 F1 81	16 83 F1 81	16 84 F1 81	16 85 F1 81	16 86 F1 81	16 87 F1 81	16 88 F1 81	0dB
⋮	⋮	⋮	⋮	⋮	⋮	⋮	⋮	
16 81 FF 81	16 82 FF 81	16 83 FF 81	16 84 FF 81	16 85 FF 81	16 86 FF 81	16 87 FF 81	16 88 FF 81	+14dB (Max)

* BYTE 3 = 0x80 + Gain Value (0x00-0x7F)

Table 16 lists the Hex codes that increase or decrease the audio output gain.

Table 16: VP-885 Hex Codes that Increase/Decrease the Audio Output Gain

	OUT 1	OUT 2	OUT 3	OUT 4	OUT 5	OUT 6	OUT 7	OUT 8
Increase	18 81 80 81	18 82 80 81	18 83 80 81	18 84 80 81	18 85 80 81	18 86 80 81	18 87 80 81	18 88 80 81
Decrease	18 81 81 81	18 82 81 81	18 83 81 81	18 84 81 81	18 85 81 81	18 86 81 81	18 87 81 81	18 88 81 81

Table 17 lists the Hex codes that set the audio output gain.

Before sending the any of the codes in Table 17, the command 2A 87 80 81 must be sent.

Table 17: VP-885 Hex Codes that Set the Audio Output Gain

OUT 1	OUT 2	OUT 3	OUT 4	OUT 5	OUT 6	OUT 7	OUT 8	LEVEL [REL]
16 81 80 81	16 82 80 81	16 83 80 81	16 84 80 81	16 85 80 81	16 86 80 81	16 87 80 81	16 88 80 81	Mute
⋮	⋮	⋮	⋮	⋮	⋮	⋮	⋮	
16 81 8D* 81	16 82 8D* 81	16 83 8D* 81	16 84 8D* 81	16 85 8D* 81	16 86 8D* 81	16 87 8D* 81	16 88 8D* 81	-100dB Mute
⋮	⋮	⋮	⋮	⋮	⋮	⋮	⋮	
16 81 BF 81	16 82 BF 81	16 83 BF 81	16 84 BF 81	16 85 BF 81	16 86 BF 81	16 87 BF 81	16 88 BF 81	-50dB
⋮	⋮	⋮	⋮	⋮	⋮	⋮	⋮	
16 81 F1 81	16 82 F1 81	16 83 F1 81	16 84 F1 81	16 85 F1 81	16 86 F1 81	16 87 F1 81	16 88 F1 81	0dB
⋮	⋮	⋮	⋮	⋮	⋮	⋮	⋮	
16 81 FF 81	16 82 FF 81	16 83 FF 81	16 84 FF 81	16 85 FF 81	16 86 FF 81	16 87 FF 81	16 88 FF 81	+13dB (Max)

*BYTE 3 = 0x80 + Gain Value (0x00-0x7F)

15 Kramer Protocol

[Section 15.1](#) describes how to switch between Protocol 3000 and Protocol 2000¹. [Section 15.2](#) defines Protocol 3000. [Section 15.3](#) defines Protocol 2000.

By default, the **VP-885** is set to Kramer's protocol 3000, but it is also compatible with Protocol 2000.

15.1 Switching Protocols

You can switch protocols either via the front panel buttons (see [Section 15.1.1](#)) or by sending protocol commands (see [Section 15.1.2](#)).

15.1.1 Switching Protocols via the Front Panel Buttons

To switch from protocol 3000 to protocol 2000, press and hold² the OUT 1 and OUT 2 buttons for a few seconds.

To switch from protocol 2000 to protocol 3000, press and hold the OUT 1 and OUT 3 buttons for a few seconds.

15.1.2 Switching Protocols via Protocol Commands

To switch from protocol 3000 to protocol 2000, send the following command:

- #P2000<CR>

To switch from protocol 2000 to protocol 3000, send the following command:

- 0x38, 0x80, 0x83, 0x81

The Windows®-based Kramer control software³ operates with protocol 2000. If the **VP-885** is set to protocol 3000, it is automatically switched to protocol 2000.

15.2 Kramer Protocol 3000

This RS-232/RS-485 communication protocol⁴ lets you control the machine from any standard terminal software (for example, Windows®)

¹ You can download our user friendly "Software for Calculating Hex Codes for Protocol 2000" from the technical support section on our Web site at: <http://www.kramerelectronics.com>

² Not as part of a switching operation

³ Download the latest software from our Web site at <http://www.kramerelectronics.com>

⁴ Not available at the time of printing. Refer to our Web site at <http://www.kramerelectronics.com> for details

HyperTerminal Application) and uses a data rate of 115200 baud, with no parity, 8 data bits, and 1 stop bit.

15.2.1 Protocol 3000 Syntax

Host message format:

START	ADDRESS (OPTIONAL)	BODY	DELIMITER
#	Destination_id@	message	CR

Simple command (commands string with only one command without addressing):

START	BODY	DELIMITER
#	Command SP Parameter_1,Parameter_2,...	CR

Commands string (formal syntax with commands concatenation and addressing):

Address@ **Command_1** Parameter1_1,Parameter1_2,... |Command_2 Parameter2_1,Parameter2_2,... |Command_3 Parameter3_1,Parameter3_2,... |...**CR**

Device message format:

Start	Address (optional)	Body	Delimiter
~	Sender_id@	message	CR LF

Device long response (Echoing command):

Start	Address (optional)	Body	Delimiter
~	Sender_id@	command SP [param1 ,param2 ...] result	CR LF

CR = Carriage return (ASCII 13 = 0x0D)

LF = Line feed (ASCII 10 = 0x0A)

SP = Space (ASCII 32 = 0x20)

15.2.2 Command Parts Details

Command:

Sequence of ASCII letters ('A'-'Z', 'a'-'z' and '-').

Command will separate from parameters with at least single space.

Parameters:

Sequence of Alfa-Numeric ASCII chars ('0'-'9','A'-'Z','a'-'z' and some special chars for specific commands), parameters will be separated by commas.

Message string:

Every command must to be entered as part of message string that begin with **message starting char** and end with **message closing char**, note that string can contain more than one command separated by pipe ("|") char.

Message starting char:

'#' for host command/query.

'~' for machine response.

Device address (Optional, for Knet):

Knet Device ID follow by '@' char.

Query sign = '?', will follow after some commands to define query request.

Message closing char =

Host messages - Carriage Return (ASCII 13), will be referred to by **CR** in this document.

Machine messages - Carriage Return (ASCII 13) + Line-Feed (ASCII 10), will be referred to by **CRLF**.

Spaces between parameters or command parts will be ignored.

Commands chain separator char:

When **message string** contains more than one command, commands will be separated by pipe ("|").

Commands entering:

If terminal software used to connect over serial \ ethernet \ USB port, that possible to directly enter all commands characters (**CR** will be entered by Enter key, that key send also **LF**, but this char will be ignored by commands parser).

Sending commands from some controllers (like Crestron) require coding some characters in special form (like \X##). Anyway, there is a way to enter all ASCII characters, so it is possible to send all commands also from controller.

(Similar way can use for URL \ Telnet support that maybe will be added in future).

Commands forms:

Some commands have short name syntax beside the full name to allow faster typing, response is always in long syntax.

Commands chaining:

It is possible to enter multiple commands in same string by '|' char (pipe).

In this case the **message starting char** and the **message closing char** will be entered just one time, in the string beginning and at the end.

All the commands in string will not execute until the closing char will be entered.

Separate response will be sent for every command in the chain.

Input string max length:

64 characters.

Backward support:

Design note: transparent supporting for protocol 2000 will be implemented by switch protocol command from protocol 3000 to protocol 2000, in protocol 2000 there is already such a command to switch protocol to ASCII protocol (#56 : H38 H80 H83 H81).

Table 18: Instruction Codes for Protocol 3000

Help commands		
Command	Syntax	Response
Protocol Handshaking	#CR	~OKCRLF
DEVICE INITIATED MESSAGES		
COMMAND		SYNTAX
Start message		Kramer Electronics LTD., Device Model Version Software Version
SWITCHER ACTIONS		

Kramer Protocol

DEVICE INITIATED MESSAGES	
COMMAND	SYNTAX
Start message	Kramer Electronics LTD. , Device Model Version Software Version
Audio-video channel has switched (AFV mode)	AV [IN>OUT]
Video channel has switched (Breakaway mode)	VID [IN>OUT]
Audio channel has switched (Breakaway mode)	AUD [IN>OUT]

RESULT CODES (ERRORS)	
COMMAND	SYNTAX
No error. Command running succeeded	[COMMAND] [PARAMETERS] OK
Protocol Errors	
Syntax Error	ERR001
Command not available for this device	ERR002
Parameter is out of range	ERR003
Unauthorized access (running command without the match login).	ERR004

BASIC ROUTING COMMANDS		
Command	Syntax	Response
Switch audio & video	AV [IN>OUT] , [IN>OUT] , ...	AV [IN>OUT] , [IN>OUT] , ... [RESULT]
Switch video only	VID [IN>OUT] , [IN>OUT] , ... Short form: V [IN>OUT] , [IN>OUT] , ...	VID [IN>OUT] , [IN>OUT] , ... [RESULT]
Note: When AFV mode is active, this command will switch also audio. If audio is breakaway – device display mode will change to show audio connections status.		
Switch audio only	AUD [IN>OUT] , [IN>OUT] , ... Short form: A [IN>OUT] , [IN>OUT] , ...	AUD [IN>OUT] , [IN>OUT] , ... [RESULT]
Note: When AFV mode is active, this command will switch also video.		
Read video connection	VID? [OUT] Short form: V? [OUT] VID? *	VID [IN>OUT] VID [IN>1] , [IN>2] , ...
Read audio connection	AUD? [OUT] Short form: A? [OUT] AUD? *	AUD [IN>OUT] AUD [IN>1] , [IN>2] , ...
Parameters Description: [IN] = Input number or '0' to disconnect output. '>' = Connection character between in and out parameters. [OUT] = Output number or '*' for all outputs.		
Examples:		
Switch Video and Audio input 3 to output 7	#AV 3>7 [CR]	~AV 3>7 OK [CRLF]
Switch Video input 2 to output 4	#V 2>4 [CR]	~VID 2>4 OK [CRLF]

Kramer Protocol

Switch Video input 4 to output 2 in machine number 6	#6@VID 4>2 <code>CR</code>	~6@VID 4>2 OK <code>CRLF</code>
Disconnect Video and Audio Output 4	#AV 0>4 <code>CR</code>	~AV 0>4 OK <code>CRLF</code>
Switch Video Input 3 to All Outputs	#V 3>* <code>CR</code>	~VID 3>* OK <code>CRLF</code>
Chaining Multiple commands*	<p>#AV 1>* V 3>4, 2>2, 82>1, 0>2 V 82>3 A 0>1 V? * <code>CR</code></p> <p>First switch all Audio and video outputs from input 1, THEN SWITCH VIDEO INPUT 3 TO OUTPUT 4, VIDEO INPUT 2 TO OUTPUT 2, VIDEO INPUT AND DISCONNECT VIDEO OUTPUT 2.</p> <p>Then switch audio input 3 to output 2, Then disconnect audio output 1. Then get status of all links (assume this is 4x4 matrix). Commands processing start after entering <code>CR</code>, response will sent for each command after processing it.</p>	<p>~AV 1>* OK<code>CRLF</code></p> <p>~VID 1>2, 3>4 OK<code>CRLF</code></p> <p>~VID 82>3 <code>ERR###</code> <code>CRLF</code></p> <p>~AUD 0>1 OK<code>CRLF</code></p> <p>~V 1>1, 0>2, 1>3, 3>4 <code>CRLF</code></p>

SIGNAL STATUS COMMANDS

Command	Syntax	Response
Change signal status	-----	SIGNAL <code>INPUT</code> , <code>STATUS</code>
Get signal status	SIGNAL? <code>INPUT</code>	SIGNAL <code>INPUT</code> , <code>STATUS</code>

PARAMETERS DESCRIPTION:

`INPUT` = Input number, '*' for all.

`STATUS` = Signal state:

"0" or "off" for not existent signal.

"1" or "on" for existent signal.

PRESET COMMANDS

Command	Syntax	Response
Store current connections to preset	PRST-STO <code>PRESET</code> Short form: PSTO <code>PRESET</code>	PRST-STO <code>PRESET</code> <code>RESULT</code>
Recall saved preset	PRST-RCL <code>PRESET</code> Short form: PRCL <code>PRESET</code>	PRST-RCL <code>PRESET</code> <code>RESULT</code>
Delete saved preset	PRST-DEL <code>PRESET</code> Short form: PDEL <code>PRESET</code>	PRST-DEL <code>PRESET</code> <code>RESULT</code>
Read video connections from saved preset	PRST-VID? <code>PRESET</code> <code>OUT</code> Short form: PVID? <code>PRESET</code> <code>OUT</code> PRST-VID? <code>PRESET</code> , *	PRST-VID <code>PRESET</code> , <code>IN</code> > <code>OUT</code> PRST-VID <code>PRESET</code> , <code>IN</code> >1, <code>IN</code> >2, ...
Read audio connections from saved preset	PRST-AUD? <code>PRESET</code> <code>OUT</code> Short form: PAUD? <code>PRESET</code> <code>OUT</code> PRST-AUD? <code>PRESET</code> , *	PRST-AUD <code>PRESET</code> , <code>IN</code> > <code>OUT</code> PRST-AUD <code>PRESET</code> , <code>IN</code> >1, <code>IN</code> >2, ...
Read saved presets list	PRST-LST? Short form: PLST?	PRST-LST <code>PRESET</code> , <code>PRESET</code> , ...

Kramer Protocol

PRESET COMMANDS		
Command	Syntax	Response
Parameters Description:		
[PRESET] = Preset number.		
[OUT] = Output in preset to show for, "*" for all.		

EXAMPLES		
Store current Audio & Video connections to preset 5	#PRST-STR 5 [CR]	~PRST-STR 5 OK [CRLF]
Recall Audio & Video connections from preset 3	#PRCL 3 [CR]	~PRST-RCL 3 OK [CRLF]
Show source of video output 2 from preset 3	#PRST-VID? 3,2 [CR]	~PRST-VID 3: 4>2 [CRLF]

OPERATION COMMANDS		
Command	Syntax	Response
Lock front panel	LOCK-FP [LOCK-MODE] Short form: LCK [LOCK-MODE]	LOCK-FP [LOCK-MODE] [RESULT]
Get front panel locking state	LOCK-FP?	LOCK-FP [LOCK-MODE]
Parameters Description:		
[LOCK-MODE] = Front panel locking state: "0" or "off" to unlock front panel buttons. "1" or "on" to lock front panel buttons.		
Restart device	RESET	RESET OK
Switch to protocol 2000*	P2000	P2000 OK
* Protocol 2000 has command to switch back to ASCII protocol (like protocol 3000)		

AUDIO PARAMETERS COMMANDS		
Command	Syntax	Response
Set audio level in specific amplifier stage.	AUD-LVL [STAGE] [CHANNEL] [VOLUME] Short form: ADL [STAGE] [CHANNEL] [VOLUME]	AUD-LVL [STAGE] [CHANNEL] [VOLUME] [RESULT]
Read audio volume level	AUD-LVL? [STAGE] [CHANNEL] Short form: ADL? [STAGE]	AUD-LVL [STAGE] [CHANNEL] [VOLUME]
Mute Audio	MUTE [MUTE MODE]	MUTE [MUTE MODE] [RESULT]

PARAMETERS DESCRIPTION:		
[STAGE] = "In", "Out" or Numeric value (present audio processing stage). For example: "0" for Input level, "1" for Pre-Amplifier, "2" for Amplifier (Out) etc.		
[CHANNEL] = Input or Output #		
[VOLUME] = Audio parameter in Kramer units, precede minus sign for negative values. ++ increase current value,		

Kramer Protocol

-- decrease current value.

MUTE MODE = 1 – Mute
0 – Unmute

MACHINE INFO COMMANDS

COMMAND	SYNTAX	RESPONSE
* Time settings commands require admin authorization		
Read in/out count	INFO-IO?	INFO-IO: IN <u>INPUTS_COUNT</u> , OUT <u>OUTPUTS_COUNT</u>
Read max presets count	INFO-PRST?	INFO-PRST: VID <u>PRESET_VIDEO_COUNT</u> , AUD <u>PRESET_AUDIO_COUNT</u>
Reset configuration to factory default	FACTORY	FACTORY <u>RESULT</u>

IDENTIFICATION COMMANDS

Command	Syntax	Response
Protocol Handshaking	# <u>CR</u>	~OK <u>CRLF</u>
Read device model	MODEL?	MODEL <u>MACHINE_MODEL</u>
Read device serial number	SN?	SN <u>SERIAL_NUMBER</u>
Read device firmware version	VERSION?	VERSION <u>MAJOR</u> <u>MINOR</u> <u>BUILD</u> <u>REVISION</u>
Set machine name	NAME <u>MACHINE_NAME</u>	NAME <u>MACHINE_NAME</u> <u>RESULT</u>
Read machine name	NAME?	NAME <u>MACHINE_NAME</u>
Reset machine name to factory default*	NAME-RST	NAME-RST <u>MACHINE_FACTORY_NAME</u> <u>RESULT</u>
<p>*Note: machine name not equal to model name. This name relevance for site viewer identification of specific machine or for network using (with DNS feature on). <u>MACHINE_NAME</u> = Up to 14 Alfa-Numeric chars. * Machine factory name = Model name + last 4 digits from serial number.</p>		
Set machine id number	MACH-NUM <u>MACHINE_NUMBER</u>	MACH-NUM <u>OLD_MACHINE_NUMBER</u> <u>NEW_MACHINE_NUMBER</u> <u>RESULT</u>
<p>* Response will send after machine number has been changed. So the replay with header will be: <u>NEW_MACHINE_NUMBER</u> @MACH-NUM <u>OLD_MACHINE_NUMBER</u> <u>NEW_MACHINE_NUMBER</u> OK</p>		

NETWORK SETTINGS COMMANDS

Set IP Address	NET-IP <u>IP_ADDRESS</u> NTIP	NET-IP <u>IP_ADDRESS</u> <u>RESULT</u>
Read IP Address	NET-IP? NTIP?	NET-IP <u>IP_ADDRESS</u>
Read MAC Address	NET-MAC?	NET-MAC <u>MAC_ADDRESS</u>



Kramer Protocol

NETWORK SETTINGS COMMANDS		
	NTMC	
Set subnet mask	NET-MASK SUBNET_MASK NTMSK	NET-MASK SUBNET_MASK RESULT
Read subnet mask	NET-MASK? NTMSK?	NET-MASK SUBNET_MASK
Set gateway address	NET-GATE GATEWAY_ADDRESS NTGT	NET-GATE GATEWAY_ADDRESS RESULT
Read subnet mask	NET-GATE? NTGT?	NET-GATE GATEWAY_ADDRESS
Set DHCP mode	NET-DHCP DHCP_MODE NTDH	NET-DHCP DHCP_MODE RESULT
Read subnet mask	NET-DHCP? NTDH?	NET-DHCP DHCP_MODE
DHCP_MODE = 0 – Don't use DHCP (Use IP set by factory or IP set command). 1 – Try to use DHCP, if unavailable use IP as above.		
Change protocol ethernet port	ETH-PORT PROTOCOL PORT ETHP	ETH-PORT PROTOCOL PORT RESULT
Read protocol ethernet port	ETH-PORT? PROTOCOL ETHP?	ETH-PORT PROTOCOL PORT
PROTOCOL = TCP / UDP (transport layer protocol) PORT = ethernet port to enter protocol 3000 commands. 1-65535 = User defined port 0 - reset port to factory default (50000 for UDP, 5000 for TCP)		

ADVANCED SWITCHING COMMANDS		
Command	Syntax	Response
Set audio follow video mode	AFV AFV-MODE	AFV AFV-MODE RESULT
Note: This command effect device front-panel mode and AUD\VID command.		
Read audio follow video mode	AFV?	AFV AFV-MODE

AFV-MODE = Front panel AFV mode "0" or "afv" to set front panel switching buttons in audio-follow-video state. "1" or "brk" to set front panel switching buttons in their previous state when audio.
--

15.3 Kramer Protocol 2000

This RS-232/RS-485 communication protocol uses four bytes of information as defined below. For RS-232, a null-modem connection between the machine and controller is used. The default data rate is 9600 baud, with no parity, 8 data bits, and 1 stop bit.

Table 19: Protocol Definitions

MSB								LSB		
		DESTINATION	INSTRUCTION							
0	D	N5	N4	N3	N2	N1	N0			
7	6	5	4	3	2	1	0			

1st byte

		INPUT							
1	I6	I5	I4	I3	I2	I1	I0		
7	6	5	4	3	2	1	0		

2nd byte

		OUTPUT							
1	O6	O5	O4	O3	O2	O1	O0		
7	6	5	4	3	2	1	0		

3rd byte

		MACHINE NUMBER							
1	OVR	X	M4	M3	M2	M1	M0		
7	6	5	4	3	2	1	0		

4th byte

1st BYTE: Bit 7 – Defined as 0.

D – “DESTINATION”: 0 - for sending information to the switchers (from the PC);

1 - for sending to the PC (from the switcher).

N5...N0 – “INSTRUCTION”

The function that is to be performed by the switcher(s) is defined by the INSTRUCTION (6 bits). Similarly, if a function is performed via the machine’s keyboard, then these bits are set with the INSTRUCTION NO., which was performed. The instruction codes are defined according to the table below (INSTRUCTION NO. is the value to be set for N5...N0).

2nd BYTE: Bit 7 – Defined as 1.

I6...I0 – “INPUT”.

When switching (ie. instruction codes 1 and 2), the INPUT (7 bits) is set as the input number which is to be switched. Similarly, if switching is done via the machine’s front-panel, then these bits are set with the INPUT NUMBER which was switched. For other operations, these bits are defined according to the table.

3rd BYTE: Bit 7 – Defined as 1.

O6...O0 – “OUTPUT”.

When switching (ie. instruction codes 1 and 2), the OUTPUT (7 bits) is set as the output number which is to be switched. Similarly, if switching is done via the machine’s front-panel, then these bits are set with the OUTPUT NUMBER which was switched. For other operations, these bits are defined according to the table.

4th BYTE: Bit 7 – Defined as 1.

Kramer Protocol

Bit 5 – Don't care.

OVR – Machine number override.

M4...M0 – MACHINE NUMBER.

Used to address machines in a system via their machine numbers. When several machines are controlled from a single serial port, they are usually configured together with each machine having an individual machine number. If the OVR bit is set, then all machine numbers will accept (implement) the command, and the addressed machine will reply.

For a single machine controlled via the serial port, always set M4...M0 = 1, and make sure that the machine itself is configured as MACHINE NUMBER = 1.

Table 20: Instruction Codes for Protocol 2000

Note: All values in the table are decimal, unless otherwise stated.

INSTRUCTION		DEFINITION FOR SPECIFIC INSTRUCTION		NOTE
#	DESCRIPTION	INPUT	OUTPUT	
0	RESET VIDEO	0	0	1
1	SWITCH VIDEO	Set equal to video input which is to be switched (0 = disconnect)	Set equal to video output which is to be switched (0 = to all the outputs)	2
2	SWITCH AUDIO	Set equal to audio input which is to be switched (0 = disconnect)	Set equal to audio output which is to be switched (0 = to all the outputs)	2
3	STORE VIDEO STATUS	Set as SETUP #	0 - to store 1 - to delete	2, 3
4	RECALL VIDEO STATUS	Set as SETUP #	0	2, 3
5	REQUEST STATUS OF A VIDEO OUTPUT	Set as SETUP #	Equal to output number whose status is reqd	4, 3
6	REQUEST STATUS OF AN AUDIO OUTPUT	Set as SETUP #	Equal to output number whose status is reqd	4, 3
8	BREAKAWAY SETTING	0	0 - audio-follow-video 1 - audio breakaway	2
11	REQUEST BREAKAWAY SETTING	Set as SETUP #	0 - Request audio breakaway setting	3, 4, 6
15	REQUEST WHETHER SETUP IS DEFINED / VALID INPUT IS DETECTED	SETUP # or Input #	0 - for checking if setup is defined 1 - for checking if input is valid	8
16	ERROR / BUSY	For invalid / valid input (i.e. OUTPUT byte = 4 or OUTPUT byte = 5), this byte is set as the input #	0 - error 1 - invalid instruction 2 - out of range 3 - machine busy 4 - invalid input 5 - valid input 6 - RX buffer overflow	9, 25
22	SET AUDIO PARAMETER	Equal to input / output number whose parameter is to be set (0 = all)	Set as parameter value	2, 24
24	INCREASE / DECREASE AUDIO PARAMETER	Equal to input / output number whose parameter is to be increased / decreased (0 = all)	0 - increase output 1 - decrease output 2 - increase left output 3 - decrease left output 4 - increase right output 5 - decrease right output 6 - increase input 7 - decrease input 8 - increase left input 9 - decrease left input 10 - increase right input 11 - decrease right input	2
25	REQUEST AUDIO PARAMETER	Equal to input / output number whose parameter is requested	0	6, 24
30	LOCK FRONT PANEL	0 - Panel unlocked 1 - Panel locked	0	2
31	REQUEST WHETHER PANEL IS LOCKED	0	0	16

Kramer Protocol

#	INSTRUCTION DESCRIPTION	DEFINITION FOR SPECIFIC INSTRUCTION		NOTE
		INPUT	OUTPUT	
42	AUDIO PARAMETER SETTINGS FOR INSTRUCTIONS 22, 24, 25	INPUT Bit: 10 - 0=input; 1=output 11 - Left 12 - Right	0 - Gain 1 - Bass 2 - Treble 3 - Midrange 4 - Mix On	24
56	CHANGE TO ASCII	0	Kramer protocol 3000	19
61	IDENTIFY MACHINE	1 - video machine name 2 - audio machine name 3 - video software version 4 - audio software version	0 - Request first 4 digits 1 - Request first suffix 2 - Request second suffix 3 - Request third suffix 10 - Request first prefix 11 - Request second prefix 12 - Request third prefix	13
62	DEFINE MACHINE	1 - number of inputs 2 - number of outputs 3 - number of setups	1 - for video 2 - for audio	14

NOTES on the above table:

NOTE 1 - When the master switcher is reset, (e.g. when it is turned on), the reset code is sent to the PC. If this code is sent to the switchers, it will reset according to the present power-down settings.

NOTE 2 - These are bi-directional definitions. That is, if the switcher receives the code, it will perform the instruction; and if the instruction is performed (due to a keystroke operation on the front panel), then these codes are sent. For example, if the HEX code

01 85 88 83

was sent from the PC, then the switcher (machine 3) will switch input 5 to output 8. If the user switched input 1 to output 7 via the front panel keypad, then the switcher will send HEX codes:

41 81 87 83

to the PC.

When the PC sends one of the commands in this group to the switcher, then, if the instruction is valid, the switcher replies by sending to the PC the same four bytes that it was sent (except for the first byte, where the DESTINATION bit is set high).

NOTE 3 - SETUP # 0 is the present setting. SETUP # 1 and higher are the settings saved in the switcher's memory, (i.e. those used for Store and Recall).

NOTE 4 - The reply to a "REQUEST" instruction is as follows: the same instruction and INPUT codes as were sent are returned, and the OUTPUT is assigned the value of the requested parameter. The replies to instructions 10 and 11 are as per the definitions in instructions 7 and 8 respectively. For example, if the present status of machine number 5 is breakaway setting, then the reply to the HEX code

0B 80 80 85

would be HEX codes

4B 80 81 85

NOTE 6 - If INPUT is set to 127 for these instructions, then, if the function is defined on this machine, it replies with OUTPUT=1. If the function is not defined, then the machine replies with OUTPUT=0, or with an error (invalid instruction code).

If the INPUT is set to 126 for these instructions, then, if possible, the machine will return the current setting of this function, even for the case that the function is not defined. For example, for a video switcher which always switches during the VIS of input #1, (and its VIS setting cannot be programmed otherwise), the reply to the HEX code

0A FE 80 81 (ie. request VIS setting, with INPUT set as 126dec)

would be HEX codes

4A FE 81 81 (ie. VIS setting = 1, which is defined as VIS from input #1).

Kramer Protocol

NOTE 8 - The reply is as in TYPE 3 above, except that here the OUTPUT is assigned with the value 0 if the setup is not defined / no valid input is detected; or 1 if it is defined / valid input is detected.

NOTE 9 - An error code is returned to the PC if an invalid instruction code was sent to the switcher, or if a parameter associated with the instruction is out of range (e.g. trying to save to a setup greater than the highest one, or trying to switch an input or output greater than the highest one defined). This code is also returned to the PC if an RS-232 instruction is sent while the machine is being programmed via the front panel. Reception of this code by the switcher is not valid.

NOTE 10 – This code is reserved for internal use.

NOTE 13 - This is a request to identify the switcher/s in the system. If the OUTPUT is set as 0, and the INPUT is set as 1, 2, 5 or 7, the machine will send its name. The reply is the decimal value of the INPUT and OUTPUT. For example, for a 2216, the reply to the request to send the audio machine name would be (HEX codes):

7D 96 90 81 (i.e. 128dec+ 22dec for 2nd byte, and 128dec+ 16dec for 3rd byte).

If the request for identification is sent with the INPUT set as 3 or 4, the appropriate machine will send its software version number. Again, the reply would be the decimal value of the INPUT and OUTPUT - the INPUT representing the number in front of the decimal point, and the OUTPUT representing the number after it. For example, for version 3.5, the reply to the request to send the version number would be (HEX codes):

7D 83 85 81 (i.e. 128dec+ 3dec for 2nd byte, 128dec+ 5dec for 3rd byte).

If the OUTPUT is set as 1, then the ASCII coding of the lettering following the machine's name is sent. For example, for the VS-7588YC, the reply to the request to send the first suffix would be (HEX codes):

7D D9 C3 81 (i.e. 128dec+ ASCII for "Y"; 128dec+ ASCII for "C").

NOTE 14 - The number of inputs and outputs refers to the specific machine which is being addressed, not to the system. For example, if six 16X16 matrices are configured to make a 48X32 system (48 inputs, 32 outputs), the reply to the HEX code

3E 82 81 82 (ie. request the number of outputs)

would be HEX codes

7E 82 90 82

ie. 16 outputs

NOTE 16 - The reply to the "REQUEST WHETHER PANEL IS LOCKED" is as in NOTE 4 above, except that here the OUTPUT is assigned with the value 0 if the panel is unlocked, or 1 if it is locked.

NOTE 19 – After this instruction is sent, the unit will respond to the ASCII command set defined by the OUTPUT byte. The ASCII command to operate with the HEX command set must be sent in order to return to working with HEX codes.

NOTE 24 – Further information needed in instructions 21, 22, 25 and 26, is sent using instruction 42 – which is sent prior to the instruction. For example, to request the audio gain value of right input # 9, send hex codes

2A 84 80 81

and then send HEX codes

19 89 81 81.

To set MIX mode, send hex codes

2A 81 84 81

and then send HEX codes

16

NOTE 25 – For units which detect the validity of the video inputs, Instruction 16 will be sent whenever the unit detects a change in the state of an input (in real-time).

For example, if input 3 is detected as invalid, the unit will send the HEX codes

10 83 84 81

If input 7 is detected as valid, then the unit will send HEX codes

10 87 85 81

LIMITED WARRANTY

Kramer Electronics (hereafter *Kramer*) warrants this product free from defects in material and workmanship under the following terms.

HOW LONG IS THE WARRANTY

Labor and parts are warranted for seven years from the date of the first customer purchase.

WHO IS PROTECTED?

Only the first purchase customer may enforce this warranty.

WHAT IS COVERED AND WHAT IS NOT COVERED

Except as below, this warranty covers all defects in material or workmanship in this product. The following are not covered by the warranty:

1. Any product which is not distributed by Kramer, or which is not purchased from an authorized Kramer dealer. If you are uncertain as to whether a dealer is authorized, please contact Kramer at one of the agents listed in the Web site www.kramerelectronics.com.
2. Any product, on which the serial number has been defaced, modified or removed, or on which the WARRANTY VOID IF TAMPERED sticker has been torn, reattached, removed or otherwise interfered with.
3. Damage, deterioration or malfunction resulting from:
 - i) Accident, misuse, abuse, neglect, fire, water, lightning or other acts of nature
 - ii) Product modification, or failure to follow instructions supplied with the product
 - iii) Repair or attempted repair by anyone not authorized by Kramer
 - iv) Any shipment of the product (claims must be presented to the carrier)
 - v) Removal or installation of the product
 - vi) Any other cause, which does not relate to a product defect
 - vii) Cartons, equipment enclosures, cables or accessories used in conjunction with the product

WHAT WE WILL PAY FOR AND WHAT WE WILL NOT PAY FOR

We will pay labor and material expenses for covered items. We will not pay for the following:

1. Removal or installations charges.
2. Costs of initial technical adjustments (set-up), including adjustment of user controls or programming. These costs are the responsibility of the Kramer dealer from whom the product was purchased.
3. Shipping charges.

HOW YOU CAN GET WARRANTY SERVICE

1. To obtain service on you product, you must take or ship it prepaid to any authorized Kramer service center.
2. Whenever warranty service is required, the original dated invoice (or a copy) must be presented as proof of warranty coverage, and should be included in any shipment of the product. Please also include in any mailing a contact name, company, address, and a description of the problem(s).
3. For the name of the nearest Kramer authorized service center, consult your authorized dealer.

LIMITATION OF IMPLIED WARRANTIES

All implied warranties, including warranties of merchantability and fitness for a particular purpose, are limited in duration to the length of this warranty.

EXCLUSION OF DAMAGES

The liability of Kramer for any effective products is limited to the repair or replacement of the product at our option. Kramer shall not be liable for:

1. Damage to other property caused by defects in this product, damages based upon inconvenience, loss of use of the product, loss of time, commercial loss; or:
2. Any other damages, whether incidental, consequential or otherwise. Some countries may not allow limitations on how long an implied warranty lasts and/or do not allow the exclusion or limitation of incidental or consequential damages, so the above limitations and exclusions may not apply to you.

This warranty gives you specific legal rights, and you may also have other rights, which vary from place to place.

NOTE: All products returned to Kramer for service must have prior approval. This may be obtained from your dealer.

This equipment has been tested to determine compliance with the requirements of:

- EN-50081: "Electromagnetic compatibility (EMC);
generic emission standard.
Part 1: Residential, commercial and light industry"
- EN-50082: "Electromagnetic compatibility (EMC) generic immunity standard.
Part 1: Residential, commercial and light industry environment".
- CFR-47: FCC* Rules and Regulations:
Part 15: "Radio frequency devices
Subpart B Unintentional radiators"

CAUTION!

Servicing the machines can only be done by an authorized Kramer technician. Any user who makes changes or modifications to the unit without the expressed approval of the manufacturer will void user authority to operate the equipment.

Use the supplied DC power supply to feed power to the machine.

Please use recommended interconnection cables to connect the machine to other components.

* FCC and CE approved using STP cable (for twisted pair products)





For the latest information on our products and a list of Kramer distributors, visit our Web site www.kramerelectronics.com where updates to this user manual may be found. We welcome your questions, comments, and feedback.



Caution

Safety Warning:

Disconnect the unit from the power supply before opening/servicing.



Kramer Electronics, Ltd.

Web site: www.kramerelectronics.com

E-mail: info@kramerelect.com

P/N: 2900-000555 REV 2