

# **REDDY Heater®**

## **PORTABLE FORCED AIR HEATER**

### **OWNER'S MANUAL**

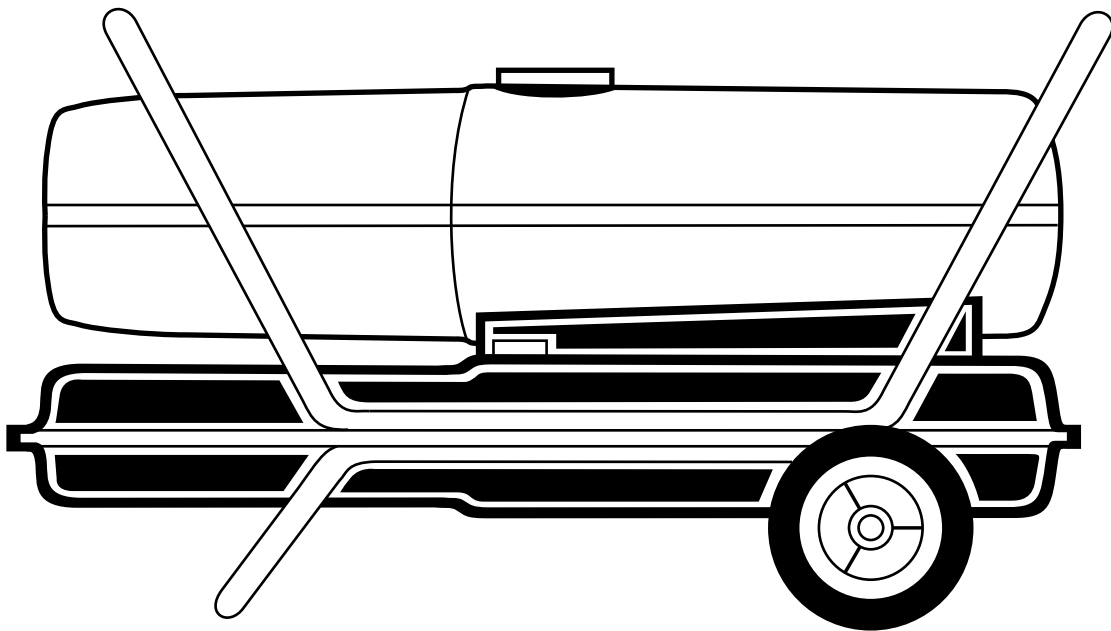

**Model RV125EDI**

#### **IMPORTANT**

**Read and understand this manual before assembling, starting or servicing heater. Improper use of heater can cause serious injury. Keep this manual for future reference.**

# CONTENTS

SECTION	PAGE
Safety Information .....	3
Introduction .....	4
Product Identification .....	4
Unpacking .....	4
Assembly .....	5
Theory of Operation .....	6
Fuels .....	6
Ventilation .....	7
Operation .....	7
Storage .....	8
Preventative Maintenance Schedule .....	8
Troubleshooting .....	9
Service Procedures .....	10
Upper Shell Removal .....	10
Fan .....	10
Air Output, Air Intake, and Lint Filters .....	11
Pump Pressure Adjustment .....	11
Fuel Filter .....	12
Spark Plug .....	12
Nozzle .....	13
Pump Rotor .....	14
Specifications .....	15
Wiring Diagram .....	15
Accessory .....	15
Illustrated Parts Breakdown and Parts List .....	16
Wheels and Handles .....	17
Burner Head Assembly .....	18
Motor and Pump Assembly .....	18
Warranty and Repair Service .....	Back Cover

## SAFETY INFORMATION

### WARNINGS

**IMPORTANT:** Read this owner's manual carefully and completely before trying to assemble, operate, or service this heater. Improper use of this heater can cause serious injury or death from burns, fire, explosion, electrical shock, and carbon monoxide poisoning.

### DANGER

**Carbon monoxide poisoning may lead to death!**

**Carbon Monoxide Poisoning:** Early signs of carbon monoxide poisoning resemble the flu, with headaches, dizziness, and/or nausea. If you have these signs, the heater may not be working properly. **Get fresh air at once!** Have heater serviced. Some people are more affected by carbon monoxide than others. These include pregnant women, people with heart or lung disease or anemia, those under the influence of alcohol, and those at high altitudes.

Make certain you read and understand all warnings. Keep this manual for reference. It is your guide to safe and proper operation of this heater.

- Use only kerosene or No. 1 fuel oil to avoid risk of fire or explosion. Never use gasoline, naphtha, paint thinners, alcohol, or other highly flammable fuels.
- Never use heater where gasoline, paint thinner, or other highly flammable vapors are present.
- Follow all local ordinances and codes when using heater.
- Never use heater without properly installed vent piping and regulator.
- This heater must have fresh air for proper operation. If not, poor fuel combustion and improper venting of flue gases will result. Carbon monoxide poisoning from backed-up flue gases could occur.
- Use only in places free of flammable vapors or high dust content.
- Use only with the electrical voltage and frequency specified on model plate.
- Use only a three-prong, grounded (earthed) extension cord.
- Minimum heater clearances from combustibles:  
Outlet: 8 Ft. (250 cm) Sides, Top, and Rear: 4 Ft. (188 cm)
- Locate heater on a stable and level surface while hot or running or a fire may occur.
- When moving or storing heater, keep heater in a level position or fuel spillage may occur.
- Keep children and animals away from heater.
- Unplug heater when not in use.
- When used with thermostat, heater may start anytime.
- Never use heater in living or sleeping areas.
- Never block air inlet (rear) or air outlet (front) of heater.
- Never move, handle, refuel, or service a hot, operating, or plugged-in heater.
- Never attach duct work to front or rear of heater.

## INTRODUCTION

This heater is designed to provide heated air. The heated air is free of harmful exhaust gases. Vent exhaust gases to the outdoors through a flue pipe, smoke-stack, or chimney. When using the heater, provide enough air for combustion and ventilation. Provide proper power supply for the heater.

This manual contains operating, maintenance, and troubleshooting instructions. A complete parts list is also included.

## PRODUCT IDENTIFICATION

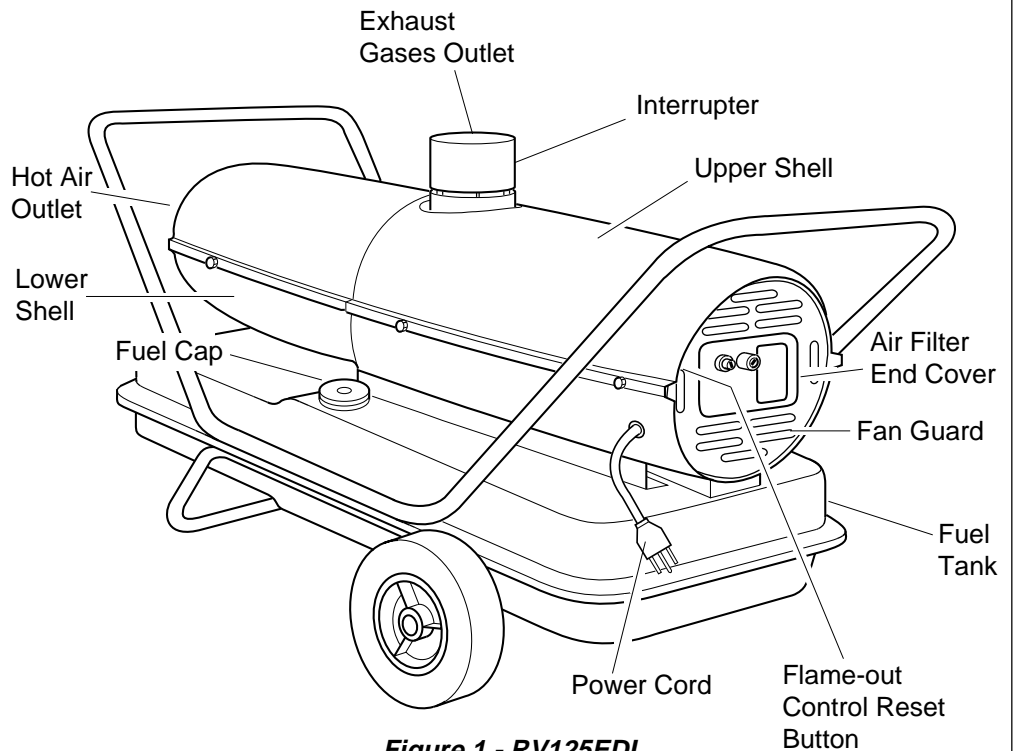

**Figure 1 - RV125EDI**

## UNPACKING

1. Remove all packing items applied to heater for shipment.
2. Remove all items from carton.
3. Check items for shipping damage. If heater is damaged, promptly inform dealer where you bought heater.

# ASSEMBLY

This heater is furnished with wheels, handles, and an interrupter. These items and the mounting hardware are found in the shipping carton.

## Tools Needed

- Medium Phillips Screwdriver
- 3/8" Open or Adjustable Wrench
- Hammer

1. Slide axle through wheel support frame. Install wheels on axle.  
*IMPORTANT:* When installing wheels, point extended hub of wheels toward wheel support frame (see Figure 2).
2. Place cap nuts on axle ends. Gently tap with hammer to secure.
3. Place heater on wheel support frame. Make sure air inlet end (rear) of heater is over wheels. Line up holes on fuel tank flange with holes on wheel support frame.
4. Place front handle and rear handle on top of fuel tank flange. Insert screws through handles, fuel tank flange, and wheel support frame. Attach nut finger tight after each screw is inserted.
5. After all screws are inserted, tighten nuts firmly.
6. Place interrupter onto combustion chamber. Secure with two screws. Save two additional screws for mounting vent pipe.

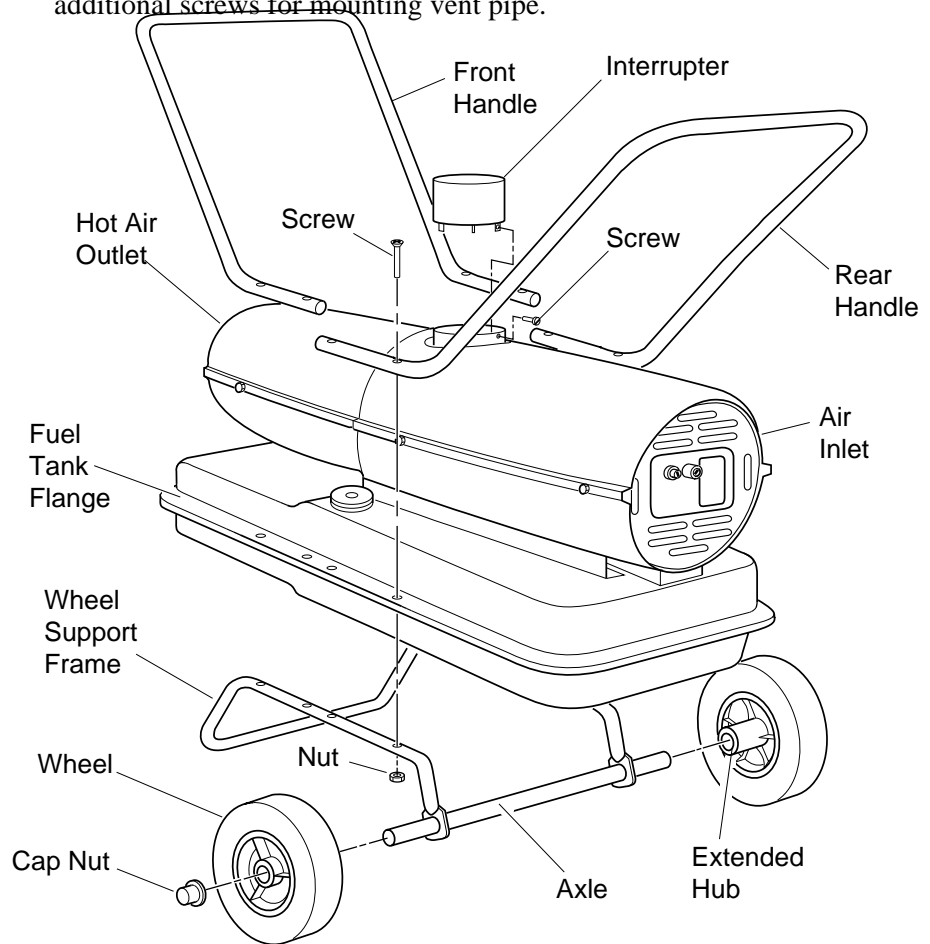

**Figure 2 - Wheel, Handle, and Interrupter Assembly**

# THEORY OF OPERATION

**The Fuel System:** The air pump forces air through the air line. The air is then pushed through the burner head nozzle. This air causes fuel to lift from the tank. A fine mist of fuel is sprayed into the combustion chamber.

**The Air System:** The motor turns the fan. The fan pushes air into and around the combustion chamber. This air is heated and provides a stream of clean, hot air. Exhaust gases are ducted out of the heater through a vent pipe. The user must supply the vent pipe.

**The Ignition System:** The electronic ignitor sends voltage to the spark plug. The spark plug ignites the fuel and air mixture.

**The Flame-Out Control System:** This system causes the heater to shut down if the flame goes out.

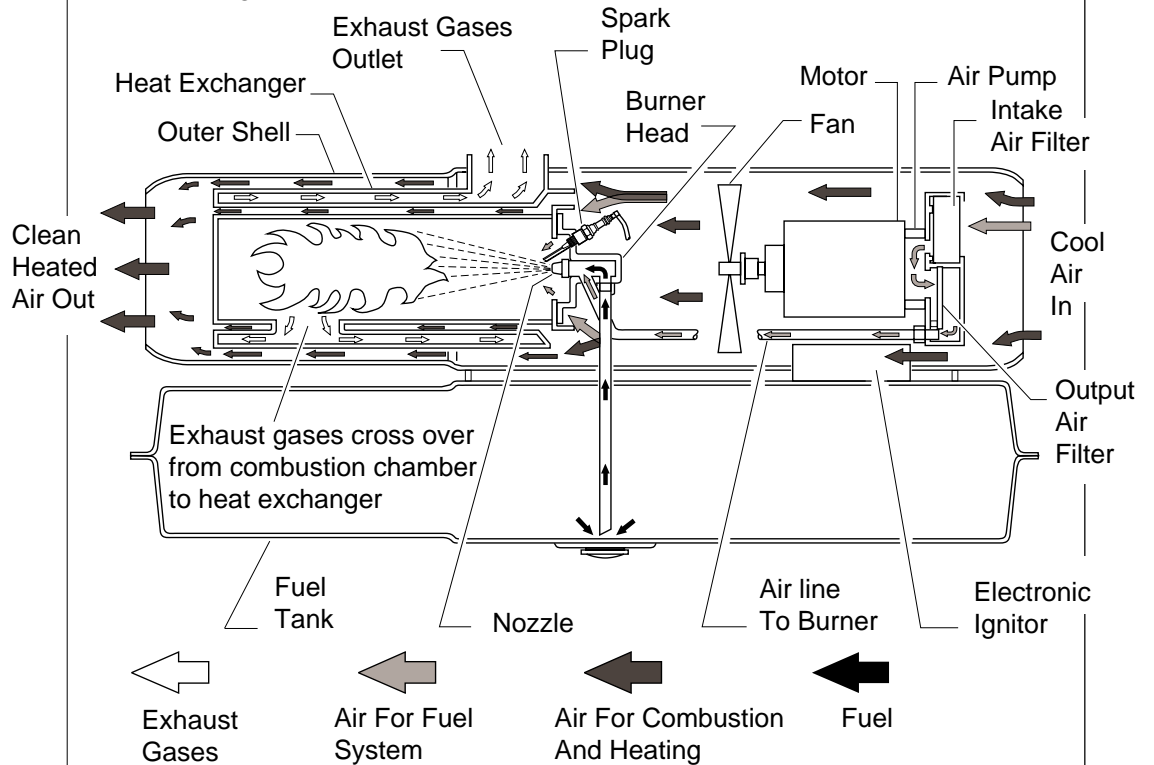

Figure 3 - Cross Section Operational View

# FUELS

## ⚠ WARNING

**Use only kerosene or No. 1 fuel oil to avoid risk of fire or explosion. Never use gasoline, naphtha, paint thinners, alcohol, or other highly flammable fuels.**

Do not use heavy fuels such as No. 2 fuel oil or No. 2 Diesel. Using heavy fuels will result in:

- clogged fuel filter and nozzle
- carbon build-up on spark plug
- the need of non-toxic anti-icer in fuel during very cold weather

**IMPORTANT:** Use a KEROSENE ONLY storage container. Be sure storage container is clean. Foreign matter such as rust, dirt, or water will cause the flame-out control to shut down heater. Foreign matter may also require you to clean fuel system often.

## VENTILATION

### **⚠ WARNING**

**Never use heater without properly installed vent pipe and regulator. You must vent heater to the outdoors. This assures proper combustion and avoids air contamination in the room.**

A standard 4 inch (10.16 cm) draft regulator is required only if total vertical and horizontal length of the vent pipe exceeds 20 feet (6.1 meters). Regulator, vent pipe, and fittings are not supplied with the heater. Purchase these items at a local hardware store.

Standard 4 inch (10.16 cm) draft regulator (required if vent pipe exceeds 20 feet [6.1 meters] in length).

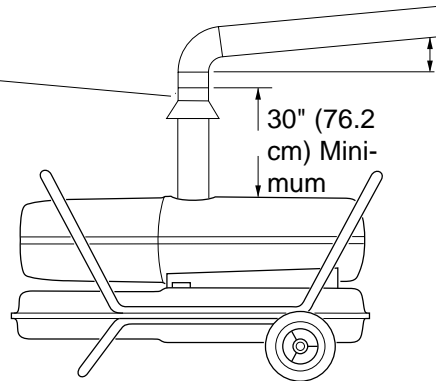

If horizontal run is needed, use at least 1 foot (30.48 cm) rise for each 10 feet (3.05 meters) of run.

**Figure 4 - Ventilation Requirements**

## OPERATION

### **⚠ WARNING**

**Review and understand the warnings in the Safety Information Section. They are needed to safely operate this heater. Follow all local codes when using this heater.**

#### **To Start Heater**

1. Follow all ventilation and safety information.
2. Fill fuel tank with kerosene or No.1 fuel oil.
3. Attach fuel cap.
4. Plug power cord into standard 230 volt/50 hertz, grounded (earthed) outlet. Use an extension cord if needed. Use only a three-wire, grounded (earthed) extension cord.

#### **Extension Cord Wire Size Requirements**

Up to 100 feet (30.5 meters) long, use 16 AWG (1.0 mm<sup>2</sup>) conductor

101 to 200 feet (30.6 to 61 meters) long, use 14 AWG (1.5 mm<sup>2</sup>) conductor

Heater will start when power cord is plugged into outlet. If not, push in flame-out control reset button (see Figure 5).

Flame-Out Control Reset Button (Fan Guard Removed)

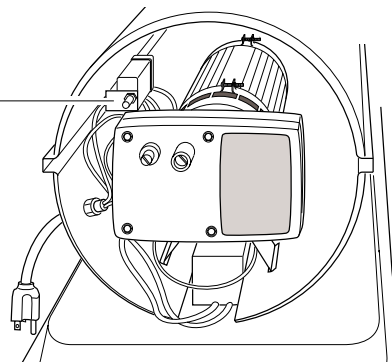

**Figure 5 - Flame-Out Control Reset Button**

*Continued*

# OPERATION

*Continued*

## To Stop Heater

1. Unplug power cord from outlet.

## To Restart Heater

1. Wait 2 minutes after stopping heater.
2. Repeat steps under *To Start Heater*, page 7.

# STORAGE

1. Drain fuel tank. Locate drain plug on underside of fuel tank. Remove drain plug to drain all fuel. Be sure all fuel is removed.
2. Replace drain plug.
3. Add one gallon (4 liters) of clean kerosene to fuel tank.
4. Attach fuel cap.
5. Move heater forwards and backwards to stir fuel.
6. Remove drain plug and drain fuel tank. Be sure all fuel is removed.
7. Replace drain plug. Properly dispose of old and dirty fuel.
8. Store heater in dry place. Make sure storage place is free of dust and corrosive fumes.

**IMPORTANT:** Do not store kerosene over summer months for use during next heating season. Using old fuel could damage heater.

## WARNING

**Never service heater while it is plugged in, operating, or hot. Severe burns and electrical shock can occur.**

# PREVENTATIVE MAINTENANCE SCHEDULE

<u>Item</u>	<u>How Often</u>	<u>How To</u>
Fuel tank	Flush every 150-200 hours of operation or as needed.	See <i>Storage</i> above.
Air output and lint filters	Replace every 500 hours of operation or once a year.	See <i>Air Output, Air Intake, and Lint Filters</i> , page 11.
Air intake filter	Wash and dry with soap and water every 500 hours of operation or replace as needed.	See <i>Air Output, Air Intake, and Lint Filters</i> , page 11.
Fuel filter	Clean twice a heating season or replace as needed.	See <i>Fuel Filter</i> , page 12.
Spark plug	Clean and regap every 600 hours operation or replace as needed.	See <i>Spark Plug</i> , page 12.
Fan blades	Clean each season or as needed.	See <i>Fan</i> , page 10.
Motor	Not required/permanently lubricated	



# TROUBLE-SHOOTING

## WARNING

Never service heater while it is plugged in, operating, or hot. Severe burns and electrical shock can occur.

<b>OBSERVED FAULT</b>	<b>POSSIBLE CAUSE</b>	<b>REMEDY</b>
Heater ignites, but flame-out control shuts off heater after a short period of time.	Wrong pump pressure	See <i>Pump Pressure Adjustment</i> , page 11.
	Dirty air output, air intake and lint filters	See <i>Air Output, Air Intake and Lint Filters</i> , page 11.
	Dirty fuel filter	See <i>Fuel Filter</i> , page 12.
	Dirt in nozzle	See <i>Nozzle</i> , page 13.
	Dirty photocell lens	Clean photocell lens.
	Bad flame-out control	Replace flame-out control.
Heater will not ignite, but motor runs for a short period of time.	Wrong pump pressure	See <i>Pump Pressure Adjustment</i> , page 11.
	Carbon deposits on spark plug and/or improper gap	See <i>Spark Plug</i> , page 12.
	Dirty fuel filter	See <i>Fuel Filter</i> , page 12.
	Dirt in nozzle	See <i>Nozzle</i> , page 13.
	Water in fuel tank	Drain and flush fuel tank with clean kerosene. See <i>Storage</i> , page 8.
<b> WARNING: High Voltage!</b>		
	Electronic ignitor not grounded	Make sure electronic ignitor mounting is tight.
	Bad electronic ignitor	Replace electronic ignitor.
Motor does not start when heater is plugged in, fan turns slowly or does not turn.	Flame-out control not reset	Reset flame-out control button (see Figure 5, page 7).
	Binding pump rotor	If fan is hard to turn, see <i>Pump Rotor</i> , page 14.

# SERVICE PROCEDURES

## Upper Shell Removal

1. Remove screws along each side of heater using 5/16" nut-driver. These screws attach upper and lower shells together.
2. Lift upper shell off.
3. Remove fan guard.

## Fan

**IMPORTANT:** Remove fan from motor shaft before removing motor from heater. The weight of the motor resting on the fan could damage the fan pitch.

1. Remove upper shell (see above).
2. Use 1/8" Allen wrench to loosen setscrew which holds fan to motor shaft.
3. Slip fan off motor shaft.
4. Clean fan using a soft cloth moistened with kerosene or solvent.
5. Dry fan thoroughly.
6. Replace fan on motor shaft. Place fan hub flush with end of motor shaft (see Figure 8).
7. Place setscrew on flat of shaft. Tighten setscrew firmly (40-50 inch-pounds/ 4.5-5.6 n-m).
8. Replace fan guard and upper shell.

## ⚠ WARNING

Never service heater while it is plugged in, operating, or hot. Severe burns and electrical shock can occur.

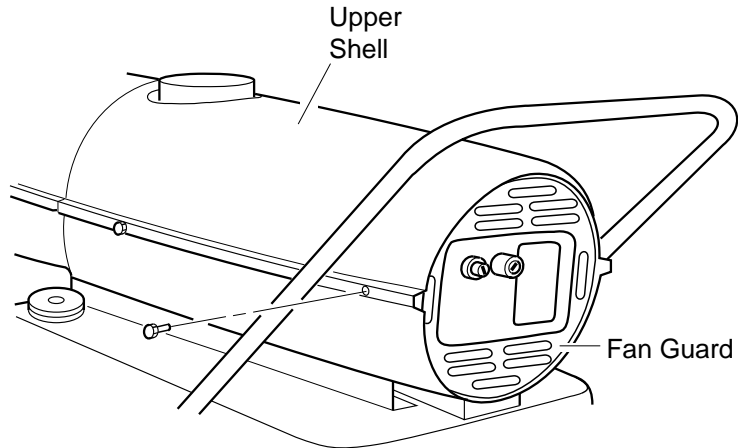

Figure 6 - Upper Shell Removal

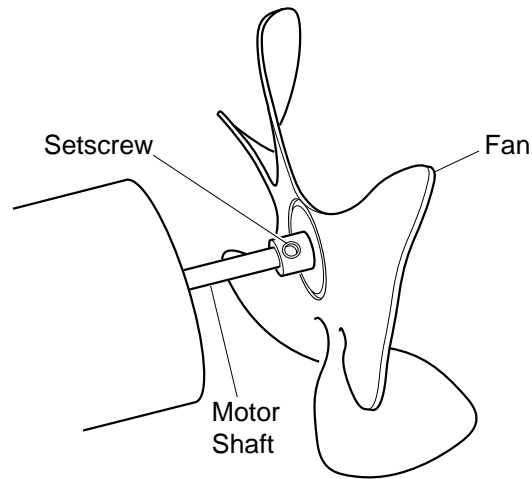

Figure 7 - Fan, Motor Shaft, and Setscrew Location

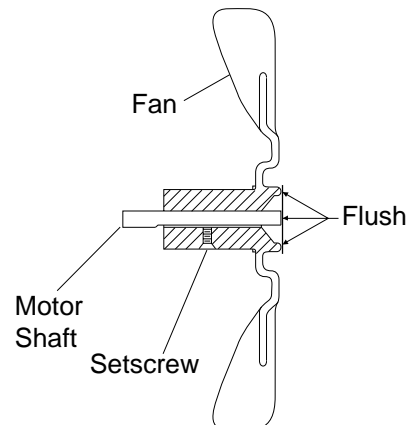
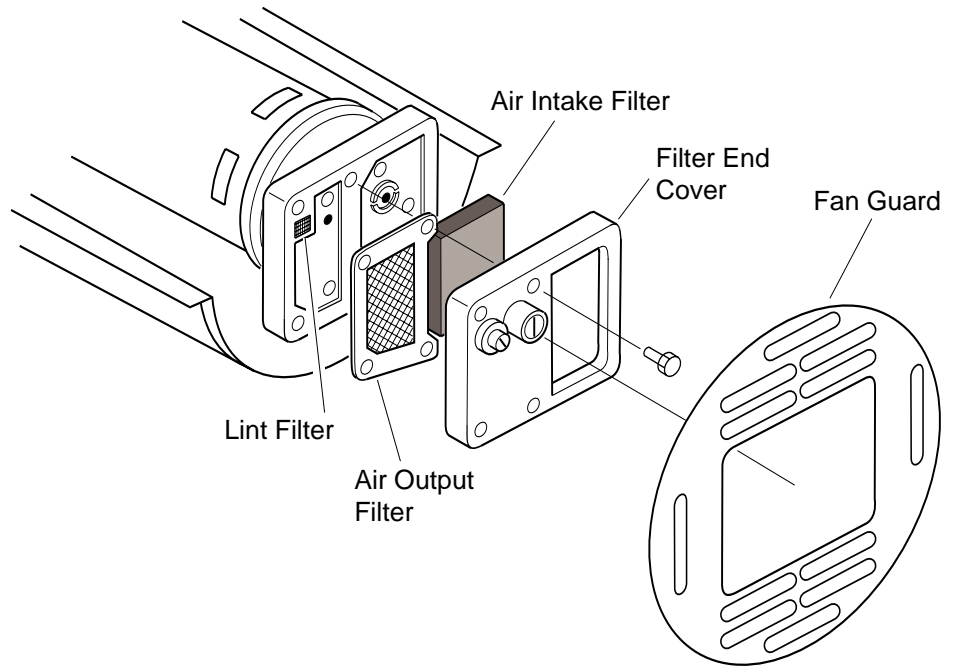

Figure 8 - Fan Cross Section

## Air Output, Air Intake, and Lint Filters

1. Remove upper shell (see page 10).
2. Remove filter end cover screws using 5/16" nut-driver.
3. Remove filter end cover.
4. Replace air output and lint filters.
5. Wash or replace air intake filter (see *Preventative Maintenance Schedule*, page 8).
6. Replace filter end cover.
7. Replace fan guard and upper shell.

**IMPORTANT:** Do not oil filters.



**Figure 9 - Air Output, Air Intake, and Lint Filters**

## Pump Pressure Adjustment

1. Remove pressure gauge plug from filter end cover.
2. Install accessory pressure gauge (part number HA1180).
3. Start heater (see *Operation*, page 7). Allow motor to reach full speed.
4. Adjust pressure. Turn relief valve to right to increase pressure. Turn relief valve to left to decrease pressure. Set pump pressure at 4 psi.
5. Remove pressure gauge. Replace pressure gauge plug in filter end cover.

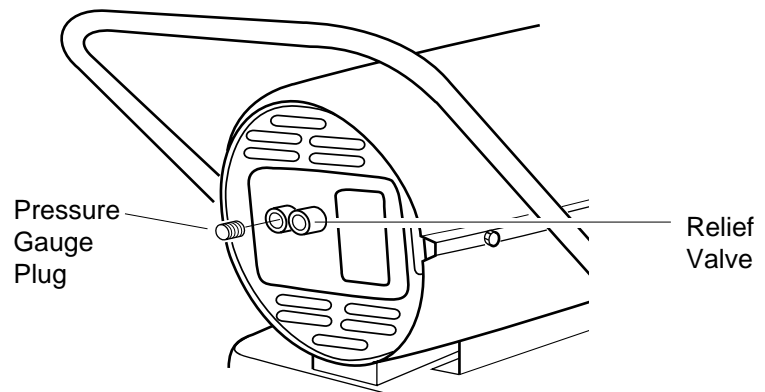

**Figure 10 - Pressure Gauge Plug Removal**

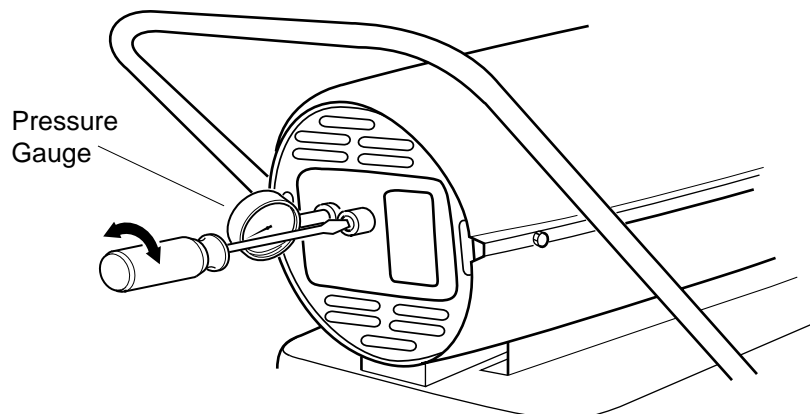

**Figure 11 - Adjusting Pump Pressure**

## Fuel Filter

1. Remove upper shell (see page 10).
2. Remove fan (see page 10).
3. Loosen flare nut using 3/4" open-end wrench. Push fuel tube down, away from burner head. Fuel filter is located inside of fuel tube.
4. Lift out fuel filter.
5. Wash fuel filter with clean fuel and replace in fuel tube.
6. Connect fuel tube to burner head. Attach flare nut until nut seats against fuel tube and fitting. Tighten 1/4 turn more using 3/4" open-end wrench (100-130 inch-pounds/11.3-14.7 n-m).
7. Replace fan (see page 10).
8. Replace fan guard and upper shell.

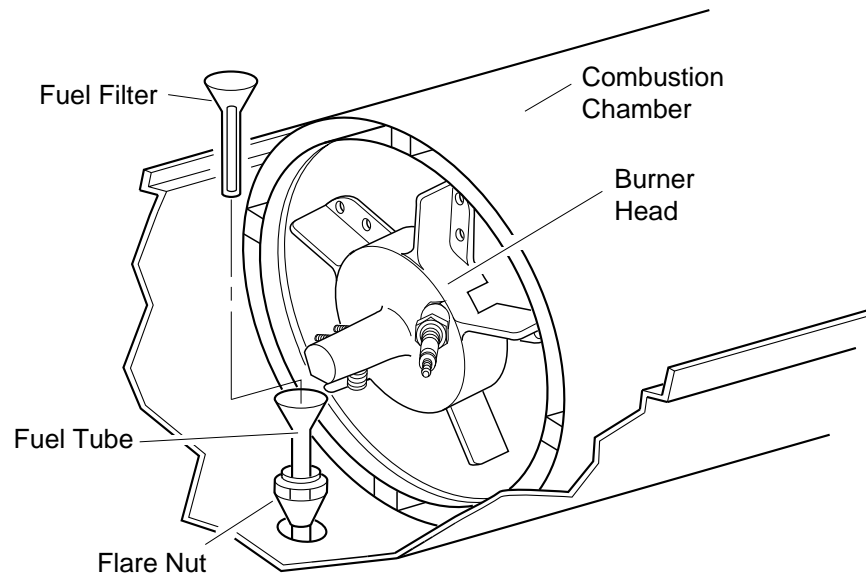

**Figure 12 - Fuel Filter Removal**

## Spark Plug

1. Remove upper shell (see page 10).
2. Remove fan (see page 10).
3. Remove spark plug wire from spark plug.
4. Remove spark plug from burner head using 13/16" open-end wrench.
5. Clean and regap spark plug electrodes to .055" (1.4mm) gap.
6. Install spark plug in burner head.
7. Attach spark plug wire to spark plug.
8. Replace fan (see page 10).
9. Replace fan guard and upper shell.

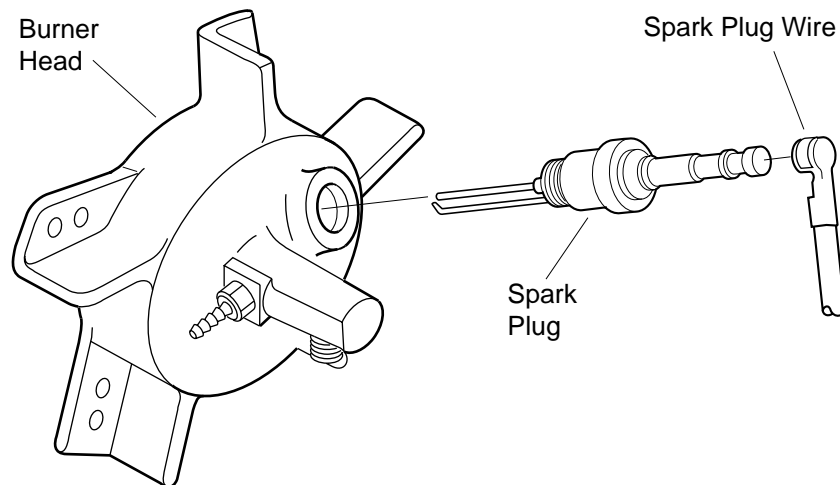

**Figure 13 - Spark Plug Removal**

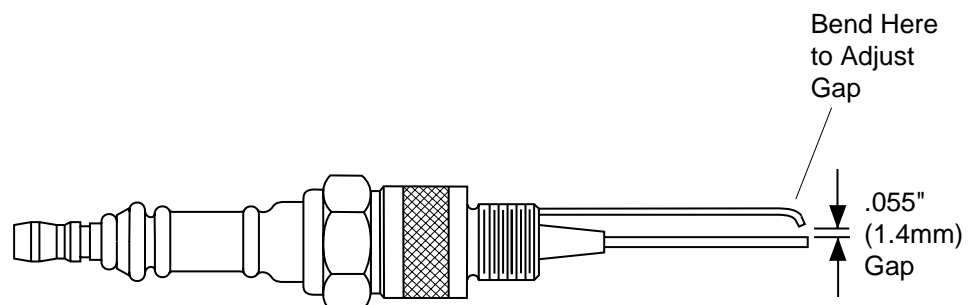

**Figure 14 - Spark Plug Gap**

## Nozzle

1. Remove upper shell (see page 10).
2. Remove fan (see page 10).
3. Remove spark plug wire from spark plug.
4. Remove spark plug from burner head using 13/16" open-end wrench.
5. Loosen flare nut using 3/4" open-end wrench. Push fuel tube down.
6. Remove air line hose from burner head.
7. Remove three (3) screws using 5/16" nut-driver and remove burner head from combustion chamber.
8. Place burner head into vise and lightly tighten.
9. Carefully remove nozzle from burner head using 5/8" socket wrench (see Figure 16).
10. Blow compressed air through face of nozzle. This will free any dirt in nozzle area.
11. Inspect nozzle sleeve for damage.
12. Replace nozzle into burner head. Tighten nozzle firmly (80-110 inch-pounds/9.1-12.4 n-m).
13. Attach burner head to combustion chamber.
14. Install spark plug in burner head.
15. Attach spark plug wire to spark plug.
16. Attach fuel tube and airline hose to burner head. Attach flare nut until nut seats against fuel tube and fitting. Tighten 1/4 turn more using 3/4" open-end wrench (100-130 inch-pounds/11.3-14.7 n-m).
17. Replace fan (see page 10).
18. Replace fan guard and upper shell.

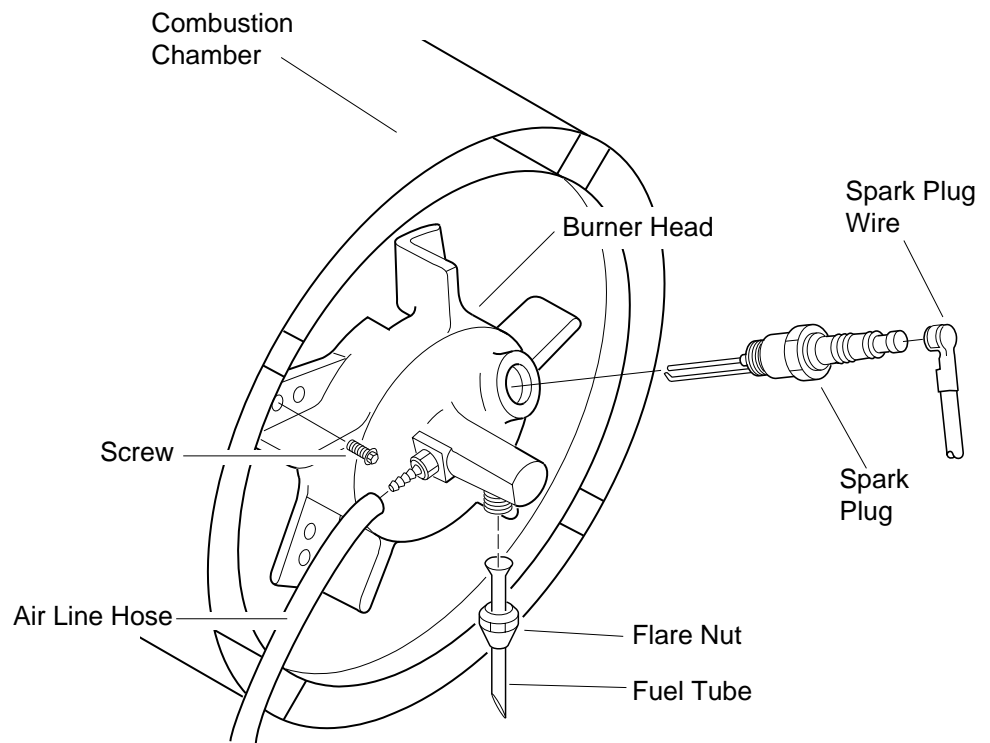

**Figure 15 - Removing Burner Head**

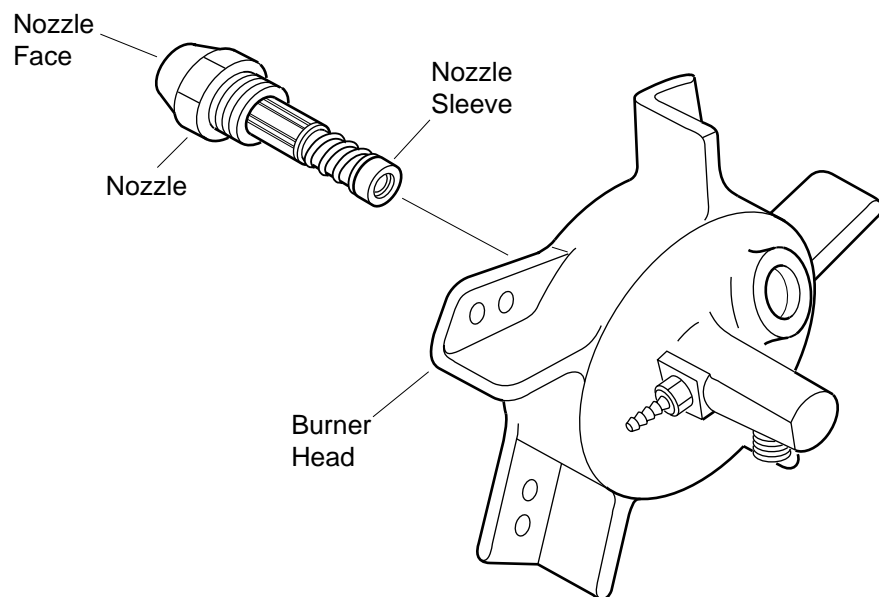

**Figure 16 - Removing Nozzle**

## Pump Rotor

### (Procedure if rotor is binding)

1. Remove upper shell (see page 10).
2. Remove filter end cover screws using 5/16" nut-driver.
3. Remove filter end cover and air filters.
4. Remove pump plate screws using 5/16" nut-driver.
5. Remove pump plate.
6. Remove rotor, insert, and blades.
7. Check for debris in pump. If debris is found, blow out with compressed air.
8. Install insert and rotor.
9. Check gap on rotor. Adjust to .003"/.004" (.076/.101mm) if needed (see Figure 18).

**Note:** Rotate rotor one full turn to insure the gap is .003"/.004" (.076/.101mm) at tightest position. Adjust if needed.

10. Install blades, pump plate, air filters, and filter end cover.
11. Replace fan guard and upper shell.
12. Adjust pump pressure (see page 11).

**Note:** If rotor is still binding, proceed as follows.

13. Perform steps 1 through 6 above.
14. Place fine grade sandpaper (600 grit) on flat surface. Sand rotor lightly in "figure 8" motion four times (see Figure 19).
15. Reinstall insert and rotor.
16. Perform steps 10 through 12 above.

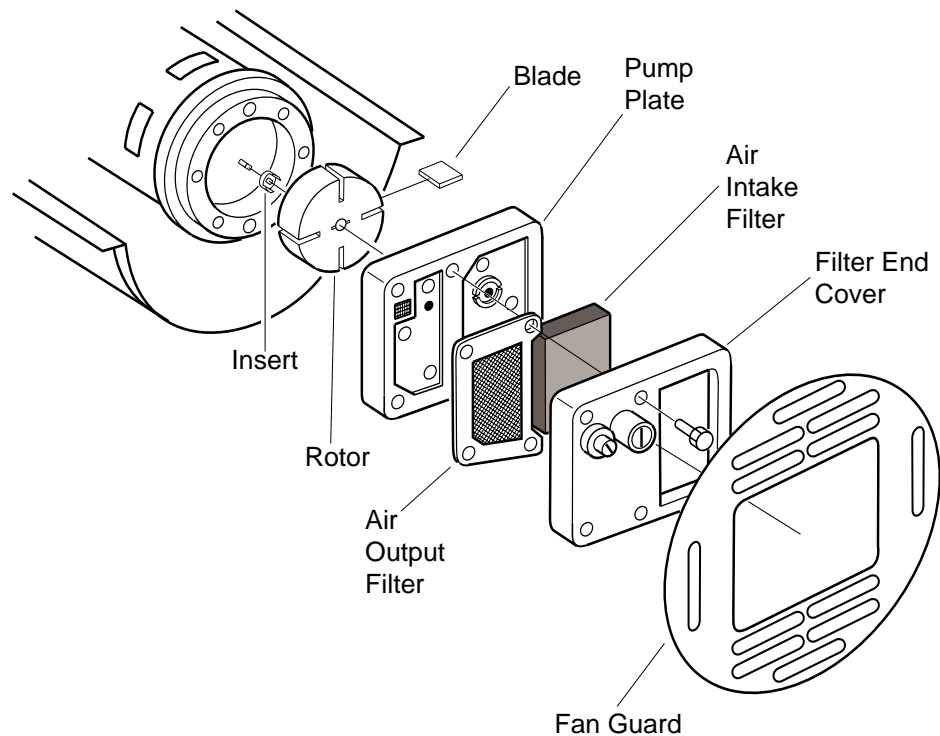

**Figure 17 - Rotor Location**

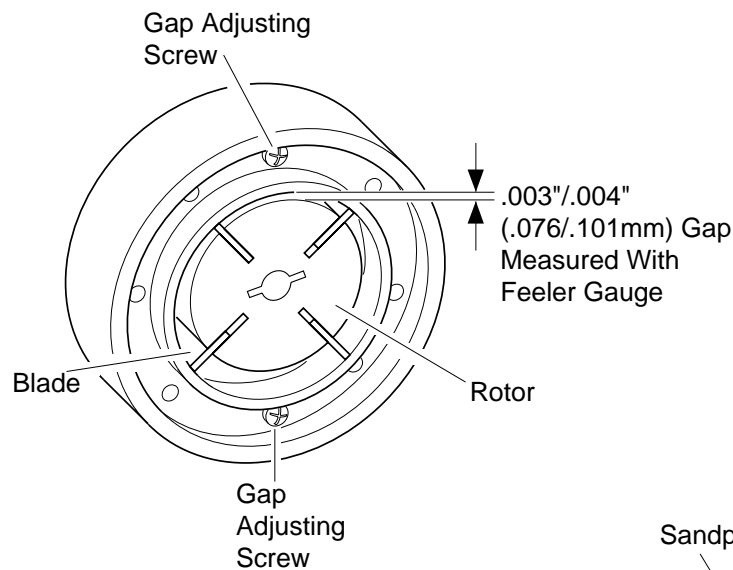

**Figure 18 - Gap Adjusting Screw Locations**

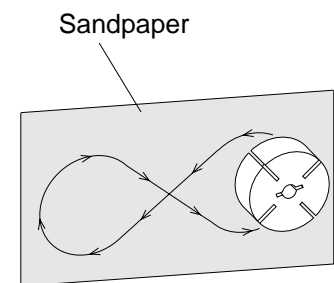
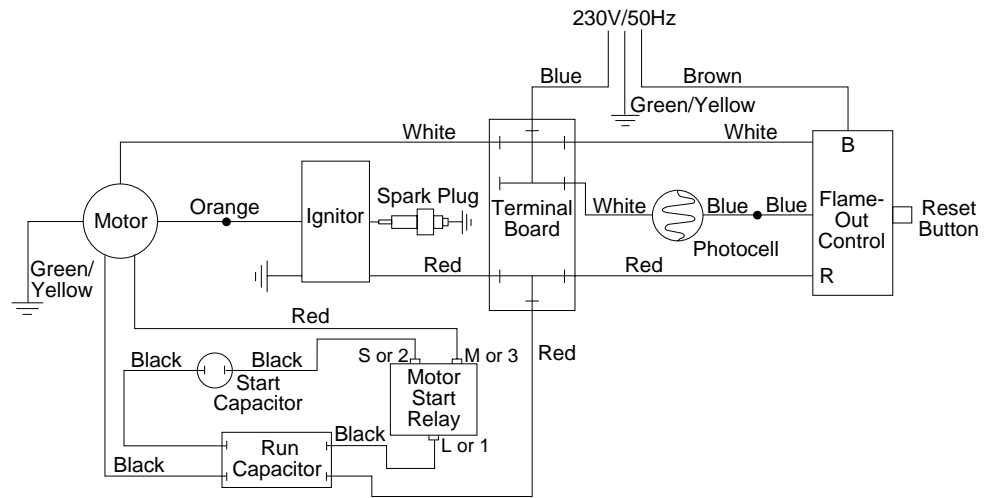

**Figure 19 - Sanding Rotor**

# SPECIFICATIONS

Input Rating (BTU/Hr)	88,000
Fuel	Use Only Kerosene or No.1 Fuel Oil
Fuel Tank Capacity (U.S. Gallons/Imperial Gallons)	13.5/11.24
Fuel Consumption (Gallons Per Hr/Imperial Gallons Per Hr)	0.66/.55
Electric Requirements	230V/50HZ
Amperage (Normal Run)	1.5
Hot Air Output (CFM/CMM)	317/8.97
RPM	2850

# WIRING DIAGRAM



**Figure 20 - Wiring Diagram**

# ACCESSORY

Purchase this accessory from your local dealer.

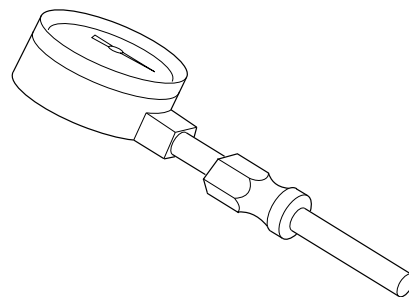

**AIR GAUGE KIT - HA1180**  
Special tool to check pump pressure.

# ILLUSTRATED PARTS BREAKDOWN

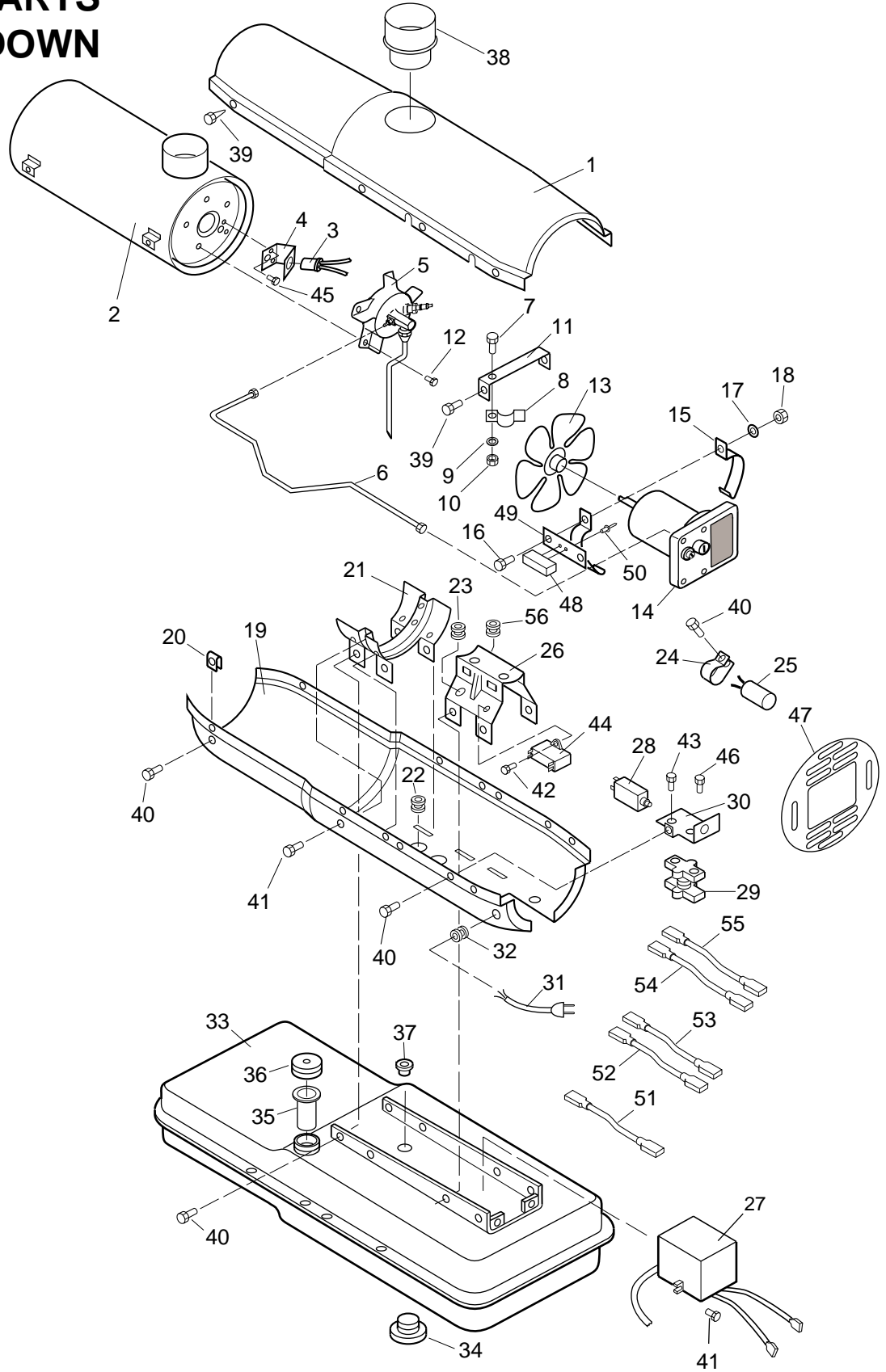



# PARTS LIST

This list contains replaceable parts used in your heater. When ordering parts, be sure to provide the correct model and serial numbers (from the model plate), then the part number and description of the desired part.

KEY NO.	PART NO.	DESCRIPTION	QTY.	KEY NO.	PART NO.	DESCRIPTION	QTY.
1	098511-76	Upper Shell	1	31	079673-03	Power Cord	1
2	098512-01	Combustion Chamber	1	32	M11143-1	Strain Relief Bushing	1
3	HA3019	Photocell Assembly	1	33	098513-08	Fuel Tank	1
4	M51330-01	Photocell Bracket	1	34	M27417	Drain Plug	1
5	**	Burner Head Assembly	1	35	HA2210	Filler Neck Screen	1
6	M23753-1	Air Line	1	36	097702-01	Fuel Cap	1
7	M12461-27	Screw, #10-32 x 1/2"	1	37	M10990-3	Rubber Bushing	1
8	M24717	Air Line Clamp	1	38	M50314-01	Interrupter	1
9	WLM-3	Lockwasher, #10	1	39	M15823-27	Screw, #10-16 x 1/2"	10
10	NPF-3C	Nut, #10-32	1	40	M11084-27	Screw, #10-16 x 1/2"	16
11	M16871	Retainer Strap	1	41	M11084-29	Screw, #10-16 x 3/4"	6
12	M11084-27	Screw, #10-16 x 1/2"	3	42	M15823-39	Screw, #8-18 x 1/2"	1
13	M17058	Fan	1	43	M11084-26	Screw, #10-16 x 3/8"	1
14	**	Motor Package Assembly	1	44	M51357-01	Capacitor (Run)	1
15	M16661	Motor Clamp	4	45	M10908-2	Screw, #6-32 x 3/8"	2
16	M51043-01	Bolt, 1/4-20 x 1 1/2"	2	46	M12461-13	Screw, #8-32 x 1/4"	2
17	WLM-4	Lockwasher, 1/4"	2	47	M50140	Fan Guard	1
18	NPC-4C	Nut, 1/4-20	2	48	099125-02	Terminal Board	1
19	098511-100	Lower Shell	1	49	099607-01	Terminal Board Bracket	1
20	M11271-8	Clip Nut	9	50	099157-01	Rivet	1
21	M12828	Shell Support Bracket	1	51	M16841-57	Wire Assembly (red 8 1/2")	1
22	M50104-03	Shorty Bushing	2	52	M9900-77	Wire Assembly (black 15")	1
23	M30865-04	Open/Closed Bushing	1	53	079010-14	Wire Assembly (red 8 7/8")	1
24	M12651-1	Capacitor Clamp	1	54	M9900-183	Wire Assembly (black 6")	1
25	M12650-3	Capacitor (Start)	1	55	M9900-184	Wire Assembly (black 15")	1
26	M16645	Motor Support Bracket	1	56	M30865-02	Open/Close Bushing	1
27	098557-07	Electronic Ignitor	1	<b>PARTS AVAILABLE- NOT SHOWN</b>			
28	097630-02	Flame-Out Control	1		M19457	Tradename Decal	1
29	M12462-13	Starting Relay	1		098235-12	General Information Decal	1
30	097060-01	Flame-Out Control Bracket	1		078918-01	Terminal Board Tab Cap	1

\*\*Not available as an assembly, order parts separately. See page 18.

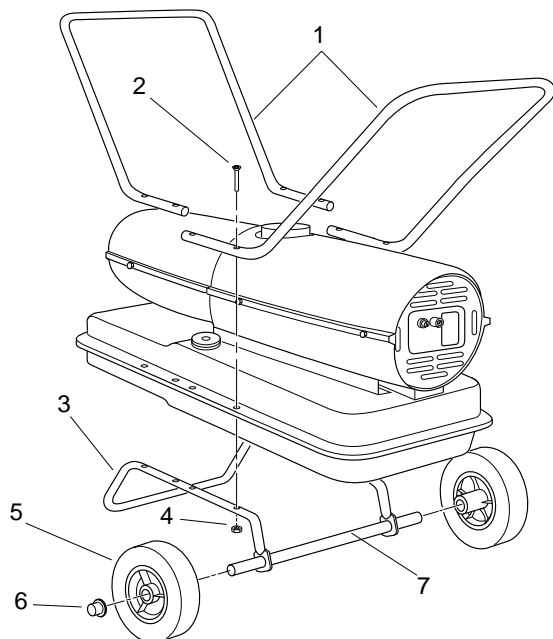

## WHEELS AND HANDLES

KEY NO.	PART NUMBER	PART DESCRIPTION	QTY.
1	HA2205	Handles	2
2	M12345-33	Screw, #10-24 x 1 3/4"	8
3	M12831-3	Frame, Wheel Support	1
4	NTC-3C	Hex Lock Nut, #10-24	8
5	097896-01	Wheel	2
6	M28526	Nut, Cap	2
7	M16801-2	Axle	1

# BURNER HEAD ASSEMBLY

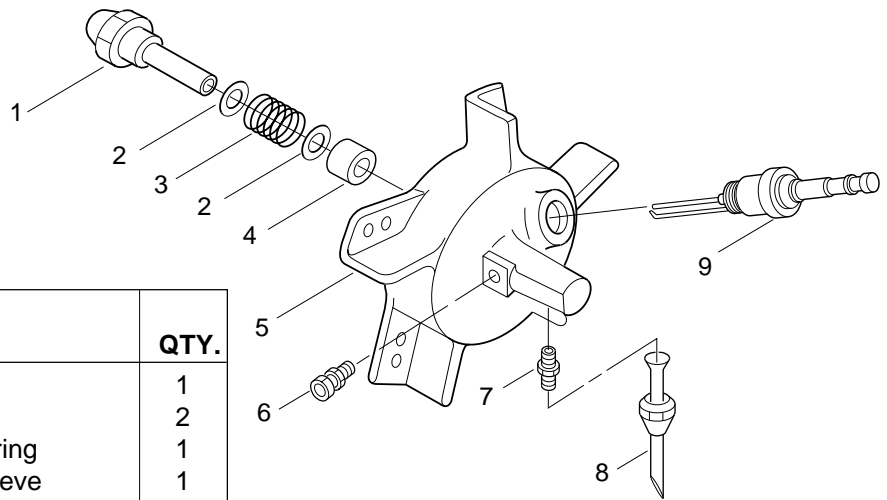

KEY NO.	PART NO.	DESCRIPTION	QTY.
1	M23103	Nozzle	1
2	M10659-1	Nozzle Seal	2
3	M10809-1	Nozzle Seal Spring	1
4	M8882	Nozzle Seal Sleeve	1
5	M51098-01	Burner Head Body	1
6	M5976	Male Connector	1
7	079685-01	Male Connector	1
8	079722-01	Fuel Tube/Fuel Filter Assy.	1
9	M10962-2	Spark Plug	1

# MOTOR AND PUMP ASSEMBLY

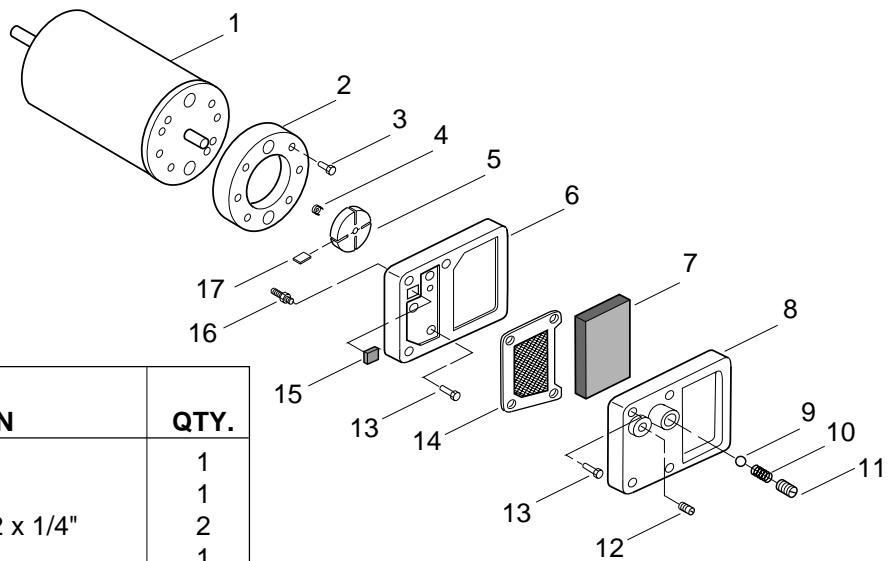

KEY NO.	PART NO.	DESCRIPTION	QTY.
1	098784-02	Motor	1
2	079965-01	Pump Body	1
3	FHPF3-2C	Screw, #10-32 x 1/4"	2
4	M22009	Rotor Insert	1
5	M22456-1	Pump Rotor	1
6	M50545	Pump Front Cover	1
7	M12179	Intake Air Filter	1
8	M16545	Filter End Cover	1
9	M8940	Ball, 1/4"	1
10	M10993-1	Compression Spring	1
11	M27694	Adjustment Screw	1
12	M22997	Plug	1
13	M12461-31	Screw, #10-32 x 1"	10
14	M12244-1	Output Filter	1
15	M11637	Lint Filter	1
16	M5976	Male Connector	1
17	M8643	Pump Blade	4



# WARRANTY AND REPAIR SERVICE

## CERTIFICATE OF GENERAL EQUIPMENT - LIMITED 90 DAY WARRANTY

DESA International warrants new Products sold by it to be free from defects in material or workmanship for a period of ninety days after date of delivery to the first user and subject to the following conditions:

DESA International's obligation and liability under this Warranty is expressly limited to repairing or replacing at DESA International's option, any parts which appear to DESA International upon inspection to have been defective in material or workmanship when shipped from the factory. Such parts shall be provided at no cost to the user, at the business establishment of any factory authorized service center or the factory during regular working hours. The Warranty shall not apply to component parts or accessories of Products not manufactured by DESA International and which carry the warranty of the manufacturer thereof, or to normal maintenance (such as pressure adjustments) or to normal maintenance parts (such as filters and spark plugs). Replacement or repair parts installed in the Product covered by this Warranty are warranted only for the remainder of this Warranty as if such parts were original components of said Product. DESA INTERNATIONAL MAKES NO OTHER EXPRESS WARRANTY. TO THE EXTENT PERMITTED BY LAW DESA INTERNATIONAL MAKES NO IMPLIED WARRANTY AND MAKES NO WARRANTY OF MERCHANTABILITY OR FITNESS FOR ANY PARTICULAR PUR-

POSE. IN ANY EVENT IMPLIED WARRANTIES INCLUDING THOSE OF MERCHANTABILITY AND FITNESS FOR A PARTICULAR PURPOSE ARE LIMITED TO THE DURATION OF THIS EXPRESS WARRANTY.

Any transportation charges, costs of installation, duty, taxes or any other charges whatsoever must be borne by the user. DESA International's obligation under this limited Warranty shall not include any liability for direct, indirect, incidental, or consequential damage or delay. If requested by DESA International, Products or parts for which a warranty claim is made are to be returned transportation prepaid by user to the factory. Any improper use, including operation after discovery of defective or worn parts, operation beyond capacity, substitution of parts not approved by DESA International, or any alteration or repair by others in such manner as in DESA International's judgement affects the Product materially and adversely, shall void this Warranty.

NO EMPLOYEE OR REPRESENTATIVE IS AUTHORIZED TO CHANGE THIS WARRANTY IN ANY WAY OR GRANT ANY OTHER WARRANTY UNLESS SUCH CHANGE IS MADE IN WRITING AND SIGNED BY AN OFFICER OF DESA INTERNATIONAL AT ITS HOME OFFICE.

### WARRANTY SERVICE

Always specify model and serial numbers when communicating with the factory.

We reserve the right to amend these specifications at any time without notice. The only Warranty applicable is our standard written Warranty. We make no other Warranty, expressed or implied.

A Service Manual is available by writing to the Technical Service Department at:

**DESA**  
**INTERNATIONAL**  
Corporate Headquarters  
2701 Industrial Drive  
P.O. Box 90004  
Bowling Green, Kentucky 42102-9004  
U.S.A.