

PROPANE CONSTRUCTION HEATERS OWNER'S MANUAL

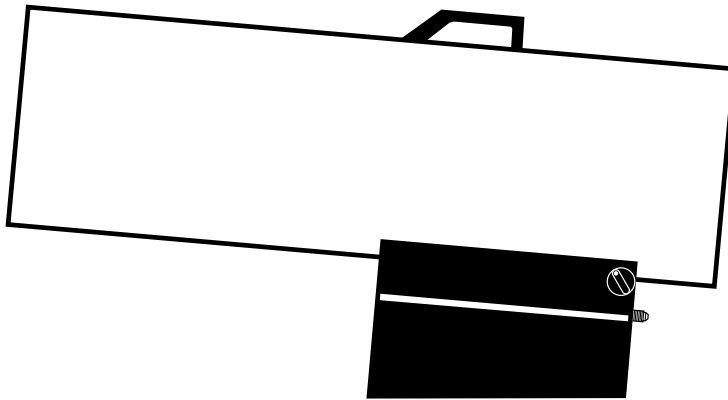

Heater Size: 100,000 Btu/Hr

IMPORTANT: Read and understand this manual before assembling, starting, or servicing heater. Improper use of heater can cause serious injury. Keep this manual for future reference.

▲ GENERAL HAZARD WARNING:

FAILURE TO COMPLY WITH THE PRECAUTIONS AND INSTRUCTIONS PROVIDED WITH THIS HEATER, CAN RESULT IN DEATH, SERIOUS BODILY INJURY AND PROPERTY LOSS OR DAMAGE FROM HAZARDS OF FIRE, EXPLOSION, BURN, ASPHYXIATION, CARBON MONOXIDE POISONING, AND/OR ELECTRICAL SHOCK.

ONLY PERSONS WHO CAN UNDERSTAND AND FOLLOW THE INSTRUCTIONS SHOULD USE OR SERVICE THIS HEATER.

IF YOU NEED ASSISTANCE OR HEATER INFORMATION SUCH AS AN INSTRUCTIONS MANUAL, LABELS, ETC. CONTACT THE MANUFACTURER.



100,000 Btu/Hr PROPANE CONSTRUCTION HEATER

SAFETY INFORMATION

WARNINGS

⚠ WARNING: FIRE, BURN, INHALATION, AND EXPLOSION HAZARD. KEEP SOLID COMBUSTIBLES, SUCH AS BUILDING MATERIALS, PAPER OR CARDBOARD, A SAFE DISTANCE AWAY FROM THE HEATER AS RECOMMENDED BY THE INSTRUCTIONS. NEVER USE THE HEATER IN SPACES WHICH DO OR MAY CONTAIN VOLATILE OR AIRBORNE COMBUSTIBLES, OR PRODUCTS SUCH AS GASOLINE, SOLVENTS, PAINT THINNER, DUST PARTICLES OR UNKNOWN CHEMICALS.

⚠ WARNING: NOT FOR HOME OR RECREATIONAL VEHICLE USE.

The heater is designed for use as a construction heater in accordance with ANSI Z83.7/CGA 2.14. Other standards govern the use of fuel gases and heating products for specific uses. Your local authority can advise you about these. The primary purpose of construction heaters is to provide temporary heating of buildings under construction, alteration or repair. Properly used, the heater provides safe economical heating. Products of combustion are vented into the area being heated.

We cannot foresee every use which may be made of our heaters. **Check with your local fire safety authority if you have questions about heater use.**

Other standards govern the use of fuel gases and heat producing products for specific uses. Your local authorities can advise you about these.

Carbon Monoxide Poisoning: Some people are more affected by carbon monoxide than others. Early signs of carbon monoxide poisoning resemble the flu, with headaches, dizziness, and/or nausea. If you have these signs, the heater may not be working properly. **Get fresh air at once!** Check for proper ventilation and have heater serviced.

Propane Gas: Propane gas is odorless. An odor-making agent is added to propane gas. The odor helps you detect a propane gas leak. However, the odor added to propane gas can fade. Propane gas may be present even though no odor exists.

Make certain you read and understand all Warnings. Keep this manual for reference. It is your guide to safe and proper operation of this heater.

- Install and use heater with care. Follow all local ordinances and codes. In the absence of local ordinances and codes, refer to the *Standard for Storage and Handling of Liquefied Petroleum Gas, ANSI/NFPA 58* and the *Propane Installation Code, CAN/CGA B149.2*. This instructs on the safe storage and handling of propane gases.
- Use only the electrical voltage and frequency specified on model plate. The electrical connections and grounding of the heater shall follow the *National Electric Code, ANSI/NFPA 70* or the *Canadian Electrical Code, Part 1*.
- Electrical grounding instructions — This appliance is equipped with a three-prong (grounding) plug for your protection against shock hazard and should be plugged directly into a properly grounded three-prong receptacle or extension cord.
- Approved by the New York City Fire Department under Certificate of Approval #4953. To be used only at construction site with applicable New York City Codes, Regulations, Rules, Directives, Permits, etc.
- This product has been approved for use in the Commonwealth of Massachusetts.
- This heater produces carbon monoxide, which is listed by the State of California as a reproductive toxin under Proposition 65.
- Use only the hose and factory preset regulator provided with the heater.
- Use only propane gas set up for vapor withdrawal.
- Provide adequate ventilation. Before using heater, provide at least a three-square-foot opening of fresh, outside air for each 100,000 Btu/Hr of rating.
- For indoor use only. Do not use heater outdoors.
- Do not use heater in occupied dwellings or in living or sleeping quarters.
- Do not use heater in basement or below ground level. Propane gas is heavier than air. If a leak occurs, propane gas will sink to the lowest possible level.
- Keep appliance area clear and free from combustible materials, gasoline, paint thinner, and other flammable vapors and liquids.
- Do not use heater in areas with high dust content. Dust is combustible.
- Minimum heater clearances from combustible materials:
 - Outlet: 8 Ft. Sides: 2 Ft.
 - Top: 6 Ft. Rear: 2 Ft.
- Keep heater at least six feet from propane tank(s). Do not point heater at propane tank(s) within 20 feet.
- Keep propane tank(s) below 100° F.
- Check heater for damage before each use. Do not use a damaged heater.
- Check hose before each use of heater. If highly worn or cut, replace with hose specified by manufacturer before using heater.
- Locate heater on stable and level surface if heater is hot or operating.
- Never block air inlet (rear) or air outlet (front) of heater.
- Keep heater away from strong drafts, wind, water spray, rain, or dripping water.
- Do not leave heater unattended.
- Keep children and animals away from heater.
- Never move, handle, or service a hot or operating heater. Severe burns may result. You must wait 15 minutes after turning heater off.
- To prevent injury, wear gloves when handling heater.
- Never attach duct work to heater.
- Do not alter heater. Keep heater in its original state.
- Do not use heater if altered.
- Turn off propane supply to heater when not in use.
- Use only original replacement parts. This heater must use design-specific parts. Do not substitute or use generic parts. Improper replacement parts could cause serious or fatal injuries.

OWNER'S MANUAL

PRODUCT IDENTIFICATION

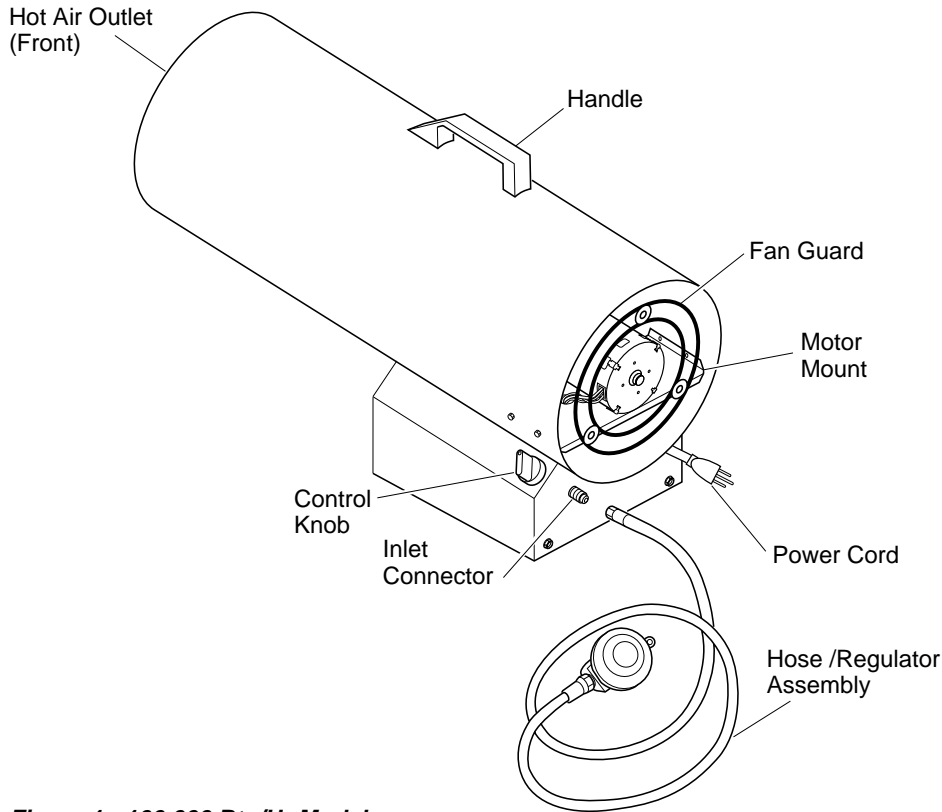

Figure 1 - 100,000 Btu/Hr Model

UNPACKING

1. Remove all packing items applied to heater for shipment. Keep plastic cover caps (attached to inlet connector and hose/regulator assembly) for storage.
2. Remove all items from carton.
3. Check all items for shipping damage. If heater is damaged, promptly inform dealer where you bought heater.

THEORY OF OPERATION

The Fuel System: The hose/regulator assembly attaches to the propane gas supply. The propane gas moves through the automatic control valve and out the nozzle.

The Air System: The motor turns the fan. The fan pushes air into and around the combustion chamber. This air is heated and provides a stream of clean, hot air.

The Ignition System: The spark transformer and ignitor lights the main burner.

The Safety Control System: This system causes the heater to shut down if the flame goes out.

Note: Some parts are located differently on some models.

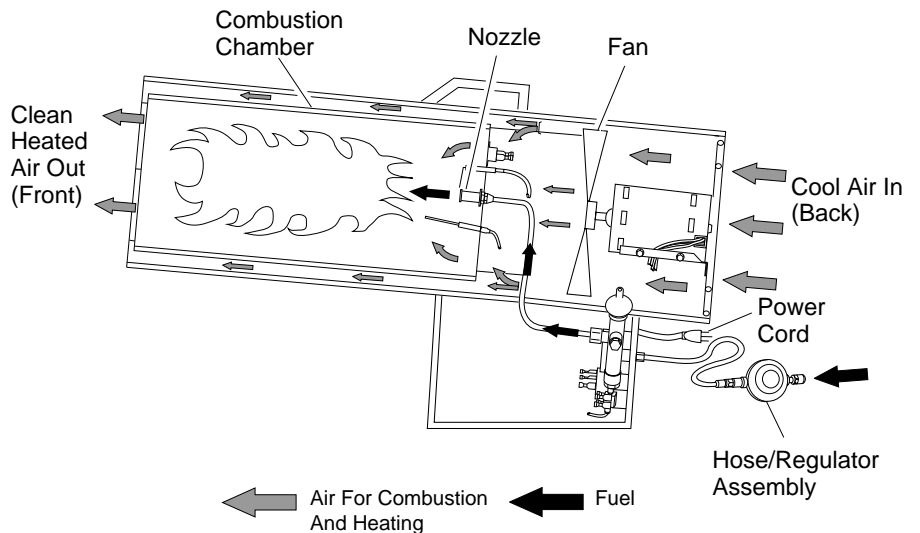

Figure 2 - Cross Section Operational View

100,000 Btu/Hr PROPANE CONSTRUCTION HEATER

PROPANE SUPPLY

Propane gas and propane tank(s) are to be furnished by the user.

Use this heater only with a propane vapor withdrawal supply system. See Chapter 5 of the *Standard for Storage and Handling of Liquefied Petroleum Gas, ANSI/NFPA 58* and the *Propane Installation Code CAN/CGA B149.2*. Your local library or fire department will have this booklet.

The amount of propane gas ready for use from propane tanks varies. Two factors decide this amount:

1. The amount of propane gas in tank(s)
2. The temperature of tank(s)

The chart below shows the number of 100 pound tanks needed to run this heater.

Temperature(°F) at Tank	Number of tanks, 100,000 Btu/Hr
32°	2
20°	2
10°	3
0°	3
-10°	(Use larger tank)
-20°	(Use larger tank)

Less gas is vaporized at lower temperatures. You may need two or more 100 pound tanks or one larger tank in colder weather. Your local propane gas dealer will help you select the proper supply system. The minimum surrounding air temperature rating for each heater is -20°F (-29°C).

INSTALLATION

⚠ WARNING: Review and understand the warnings in the Safety Information section, page 2. They are needed to safely operate this heater. Follow all local codes when using this heater.

⚠ WARNING: Test all gas piping and connections for leaks after installing or servicing. Never use an open flame to check for a leak. Apply a mixture of liquid soap and water to all joints. Bubbles forming show a leak. Correct all leaks at once.

1. Provide propane supply system (see *Propane Supply* above).
2. Connect fuel gas connector fitting on hose/regulator assembly to propane tank(s). Turn counterclockwise into threads on tank valve. Tighten firmly using wrench. **IMPORTANT:** Tighten regulator with vent pointing down. Pointing vent down protects regulator from weather damage.

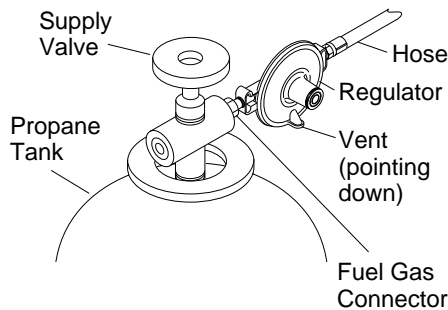

Figure 3 - Regulator With Vent Pointing Down

3. Connect hose to inlet connector. Tighten firmly using a wrench.

IMPORTANT: Extra hose or piping may be used if needed. Install extra hose or piping between hose/regulator assembly and propane tank. You must use the regulator supplied with heater.

4. Open propane supply valve on propane tank(s) slowly. **Note:** If not opened slowly, excess-flow check valve on propane tank will stop gas flow. If this happens, close propane supply valve and open again slowly.
5. Check all connections for leaks.
6. Close propane supply valve.

**100,000 Btu/Hr
Model Shown**

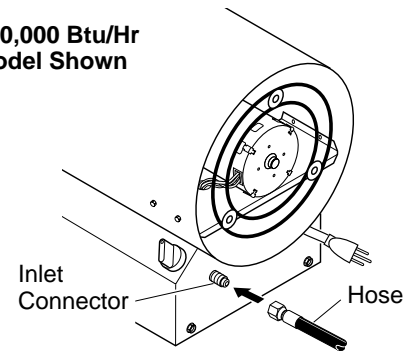

Figure 4 - Hose and Inlet Connector

VENTILATION

⚠ WARNING: Follow the minimum fresh, outside air ventilation requirements. If proper fresh, outside air ventilation is not provided, carbon monoxide poisoning can occur. Provide proper fresh, outside air ventilation before running heater.

Provide a fresh air opening of at least three square feet for each 100,000 Btu/Hr rating. Provide extra fresh air if more heaters are being used.

OWNER'S MANUAL

OPERATION

⚠WARNING: Follow the minimum fresh, outside air ventilation requirements. If proper fresh, outside air ventilation is not provided, carbon monoxide poisoning can occur. Provide proper fresh, outside air ventilation before running heater.

⚠WARNING: Review and understand the warnings in the *Safety Information* section, page 2. They are needed to safely operate this heater. Follow all local codes when using this heater.

TO START HEATER

1. Follow all installation, ventilation and safety information.
2. Locate heater on stable and level surface. Make sure strong drafts do not blow into front or rear of heater.
3. Make sure the control knob is in the OFF position.
4. Plug power cord of heater into a three-prong, grounded extension cord. Extension cord must be at least six feet long, UL/CSA listed, and of a proper size.
Extension Cord Size Requirement
Up to 100 feet long, use 16 AWG rated cord.
101 to 200 feet long, use 14 AWG rated cord.
5. Plug extension cord into a 120 volt/60 hertz, 3-hole, grounded outlet. Motor will start. Fan will turn, forcing air out front of heater.
6. Open propane supply valve on propane tank(s) slowly. *Note:* If not opened slowly, excess-flow check valve on propane tank will stop gas flow. You may hear a click from the excess-flow check valve closing. If this happens, reset the excess-flow check valve by closing propane supply valve and open again slowly.
7. Press and hold in control knob. Turn counterclockwise to the LOW position. Heater should ignite within a few seconds.

Note: If heater fails to ignite, hose may have air in it. If so, keep control knob pressed and wait 20 seconds. Release automatic control valve button and wait 20 seconds for unburned fuel to exit heater. Repeat step 7.

8. After heater ignites, wait 30 seconds. This activates the automatic control system. Release the control knob.
9. When burner remains lit, set heater at the desired heat level by turning the control valve counterclockwise. If burner goes out, turn off gas. Turn control knob fully clockwise to the lowest position. Check fuel supply. If adequate fuel is available, restart heater beginning at step 1.

TO STOP HEATER

1. Tightly close propane supply valve on propane tank(s).
2. Wait a few seconds. Heater will burn gas left in supply hoses.
3. Turn control knob to the OFF position.
4. Unplug heater.

STORAGE

⚠CAUTION: Disconnect heater from propane supply tank(s).

1. Store propane tank(s) in safe manner. See Chapter 5 of *Standard for Storage and Handling of Liquefied Petroleum Gases, ANSI/NFPA 58* and the *Propane Installation Code CAN/CGA B149.2*. Follow all local codes. Always store propane tanks outdoors.
2. Place plastic cover caps over brass fittings on inlet connector and hose/regulator assembly.
3. Store in dry, clean, and safe place. Do not store hose/regulator assembly inside heater combustion chamber.
4. When taking heater out of storage, always check inside of heater. Insects and small animals may place foreign objects in heater. Keep inside of heater free from combustible and foreign objects.

MAINTENANCE

⚠WARNINGS

- Never service heater while it is plugged in, connected to propane supply, operating, or hot. Severe burns and electrical shock can occur.
- Keep heater clear and free from combustible materials, gasoline, and other flammable vapors and liquids.
- Do not block the flow of combustion or ventilation air.

1. Keep heater clean. Clean heater annually or as needed to remove dust and debris. If heater is dirty or dusty, clean heater with a damp cloth. Use household cleaners on difficult spots.
2. Inspect heater before each use. Check connections for leaks. Apply mixture of liquid soap and water to connections. Bubbles forming show a leak. Correct all leaks at once.
3. Inspect hose/regulator assembly before each use. If hose is highly worn or cut, replace with hose specified by manufacturer.
4. Have heater inspected yearly by a qualified service agency.
5. Keep inside of heater free from combustible and foreign objects. Remove motor and other internal parts if needed to clean inside of heater (see *Service Procedures*, page 7).
6. Clean fan blades each season or as needed (see *Fan*, page 7).

100,000 Btu/Hr PROPANE CONSTRUCTION HEATER

TROUBLESHOOTING

Note: For additional help, visit DESA International's Technical Service web site at www.desatech.com.

⚠ WARNING: Never service heater while it is plugged in, connected to propane supply, operating, or hot. Severe burns and electrical shock can occur.

OBSERVED FAULT	POSSIBLE CAUSE	REMEDY
Fan does not turn when heater is plugged in.	<ol style="list-style-type: none"> 1. No electrical power to heater 2. Fan hitting inside of heater shell 3. Fan blades bent 4. Defective motor 	<ol style="list-style-type: none"> 1. Check voltage to electrical outlet. If voltage is good, check heater power cord for breaks. 2. Adjust motor/fan mount to keep fan from hitting inside of heater shell. Bend fan mount if necessary. 3. Replace fan. See <i>Fan</i>, page 7. 4. Replace motor. See <i>Motor</i>, page 7.
Heater will not ignite	<ol style="list-style-type: none"> 1. User did not follow installation or operation instructions properly 2. No spark at ignitor. To test for spark, follow step 8 under <i>Ignitor</i>, page 8. If you see spark at ignitor, have heater serviced by qualified service person. If no spark seen: <ol style="list-style-type: none"> A) Loose or disconnected ignitor wire B) Wrong spark gap C) Bad ignitor electrode D) Bad spark transformer 	<ol style="list-style-type: none"> 1. Repeat installation and operation instructions. See <i>Installation</i>, page 4 and <i>Operation</i>, page 5. 2. A) Check ignitor wire. Tighten or reattach loose ignitor wire. See Figure 10, page 8 for ignitor wire location. B) Set gap between ignitor electrode and target plate to .13"/.15". C) Replace ignitor electrode. See <i>Ignitor</i>, page 8. D) Replace spark transformer. See <i>Spark Transformer</i>, page 8.
Heater shuts down while running.	<ol style="list-style-type: none"> 1. Propane supply may be inadequate 2. High surrounding air temperature causing thermal limit device to shut down heater. 3. Restricted air flow 4. Damaged fan 5. Excessive dust or debris in surrounding area 	<ol style="list-style-type: none"> 1. A) Refill tank. B) Provide additional and/or larger tanks. See <i>Propane Supply</i>, page 4. 2. This can happen when running heater in temperatures above 85°F. Run heater in cooler temperatures. 3. Check heater inlet and outlet. Remove any obstructions. 4. Replace fan. See <i>Fan</i>, page 7. 5. Clean heater. See <i>Maintenance</i>, page 5.

⚠ WARNING: Use only in areas free of high dust content.

OWNER'S MANUAL

SERVICE PROCEDURES

⚠WARNING: Never service heater while it is plugged in, connected to propane supply, operating, or hot. Severe burns and electrical shock can occur.

MOTOR

1. While on heaters side Remove base tray.
2. Access ground screw through underside of heater base. Remove ground screw. Disconnect the green motor wire and the green power cord wire from underside of shell (see Figure 5).
3. Remove black and white motor wires from terminal board (see Figure 5).
4. Carefully push motor wires through hole in bottom of shell.
5. Remove screws holding motor mount to shell. Use nut-driver (see Figure 6).

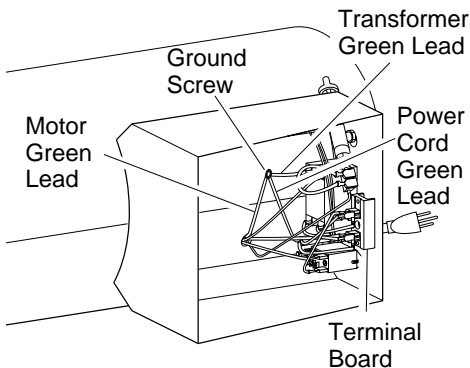

Figure 5 - Location of Ground Screw

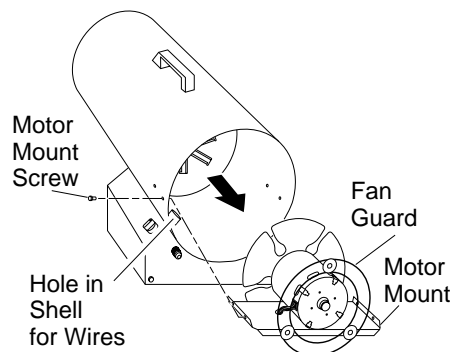

Figure 6 - Removing Motor, Motor Mount, and Fan Guard from Heater

6. Carefully pull motor and fan out of shell.

IMPORTANT: Be careful not to damage fan. Do not set motor and fan down with the weight resting on fan. This could damage fan pitch.

7. Use hex wrench to loosen setscrew which holds fan to motor shaft.
8. Remove fan. Be careful not to damage the fan blade pitch.
9. Use nut driver to remove two nuts that attach motor to motor mount.
10. Discard old motor.
11. Attach motor to motor mount with two nuts. Tighten nuts firmly.
12. Replace fan on motor shaft. Make sure set screw contacts flat surface on motor shaft.
13. Tighten set screw firmly (40-50 inch-pounds).
14. Carefully route motor wires through hole in shell (see Figure 7). Place motor, motor mount, and fan guard into rear of heater shell.
15. Insert screws through heater shell and into motor mount. Tighten screws firmly.
16. Turn heater on its side to access opening in bottom of base. Connect green wires from motor, transformer, and power cord to heater shell using ground nut (see Figure 5).
17. Attach black and white wires to terminal board (see *Wiring Diagram*, page 9, for correct locations).
18. Replace base tray.

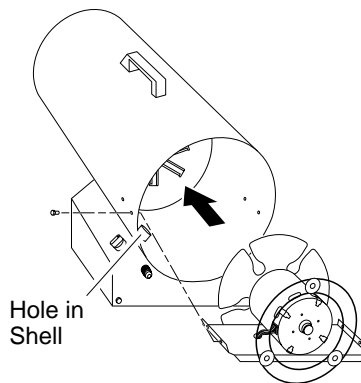

Figure 7 - Replacing Motor, Motor Mount, and Fan Guard into Heater

FAN

1. Remove motor, motor mount, and fan (see *Motor*, steps 1 through 8).
2. Clean fan using soft cloth moistened with kerosene or solvent.
3. Dry fan thoroughly.
4. Replace fan on motor shaft. Make sure setscrew is touching back of flat surface on motor shaft (see Figure 8).
5. Place setscrew on flat of shaft. Tighten setscrew firmly (40-50 inch-pounds).
6. Place motor, motor mount, and fan guard into rear of heater shell (see *Motor*, steps 14 through 18).

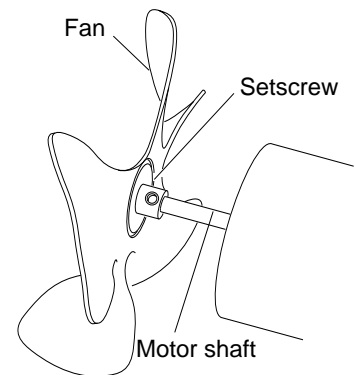

Figure 8 - Fan, Motor Shaft, and Setscrew Location

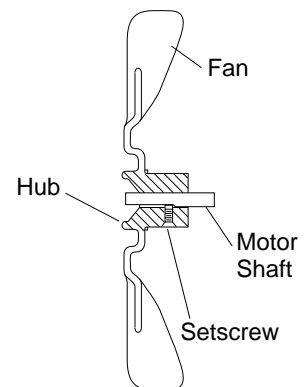

Figure 9 - Fan Cross Section

100,000 Btu/Hr PROPANE CONSTRUCTION HEATER

SERVICE PROCEDURES

Continued

SPARK TRANSFORMER

1. Remove base tray.
2. Locate and disconnect white, black, and orange wires from spark transformer.
3. Remove two screws holding spark transformer to base. Remove sheet metal nuts on transformer and install on new transformer. Discard spark transformer.
4. Install new spark transformer. Position new spark transformer in same manner as old transformer.
5. Connect white, black, and orange wires to new spark transformer. Connect wires to correct terminals as noted in step 2.
6. Replace base tray.

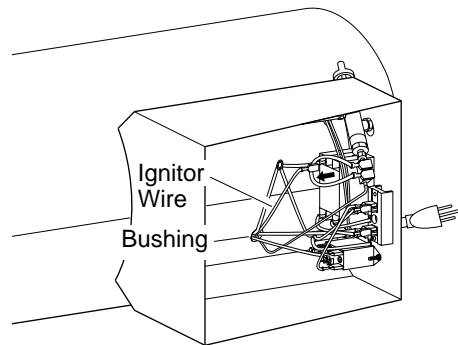

Figure 10 - Removing Ignitor Wire from Spark Transformer

IGNITOR

1. Remove motor, motor mount, and fan guard (see *Motor*, page 7, steps 1 through 6).
2. Remove orange ignitor wire from ignitor.
3. Remove ignitor mounting screw from rear head using nut-driver or standard screwdriver (see Figure 11).

4. Remove ignitor from rear head.
5. Install new ignitor. Attach ignitor to rear head with ignitor mounting screw.
6. Attach ignitor wire.
7. Check gap between ignitor electrode and nozzle to .13"/.15" (see Figure 12).
8. Test for spark.

WARNING: Make sure heater is disconnected from propane supply. Heater could ignite causing severe burns.

Plug into extension cord and watch for spark between ignitor electrode and nozzle.

9. Place motor, motor mount, and fan guard into rear of heater shell (see *Motor*, page 7, steps 14 through 18).

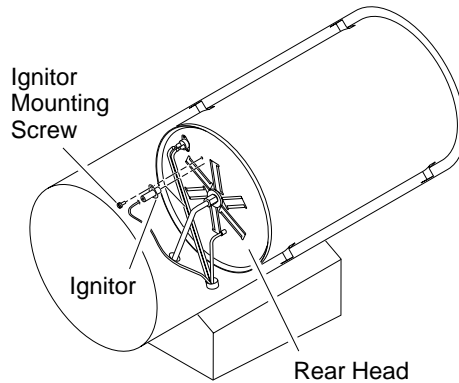

Figure 11 - Removing Ignitor Mounting Screw and Ignitor

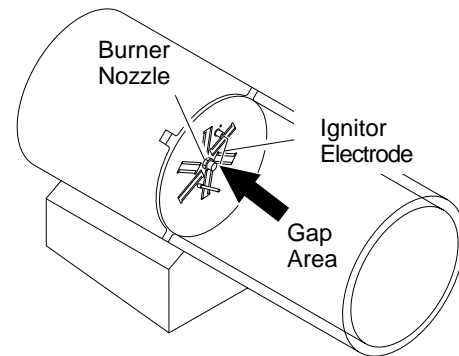

Figure 12 - Clearance between Ignitor Electrode and Target Plate

ACCESSORIES

Purchase accessories and parts from your nearest dealer or service center. If your dealer or service center can not supply an accessory or part, either contact your nearest Parts Central (listed in the separate Authorized Service Center booklet) or call DESA International's Parts Department at 1-800-972-7879 for referral information. You can also write to the address listed on the back page of this manual.

Hose: LPA1000 - For 100,000 Btu/Hr Model

A 10 foot hose for locating heater further away from propane tank(s).

Regulator: LPA2150 - For 100,000 Btu/Hr Model

Hose and Regulator Assembly: LPA3100 - For 100,000 Btu/Hr Model

Fuel Gas Connector: LPA4020 - For All Models

A POL adapter with excess-flow

TECHNICAL SERVICE

You may have further questions about this heater. If so, contact DESA International's Technical Service Department at 1-800-323-5190.

You can also visit DESA International's Technical Service web site at www.desatech.com.

OWNER'S MANUAL

SPECIFICATIONS

Output Rating (Btu/Hr)	65,000	85,000	100,000
Fuel Consumption			
Gallons/Hour	0.7	.93	1.1
Pounds/Hour	3.0	3.9	4.6
Fuel	Propane Vapor Only		
Supply Pressure To Regulator			
Minimum (for purposes of input adjustment)		10 psi	
Maximum		Tank Pressure	
Regulator Outlet Pressure		(Factory Preset)	
Manifold Pressure		10" WC	
Hot Air Output (CFM Approx)		475	
Motor		3,200 RPM	
Electric Input		120 V/60 Hz	
Amperage		2.9	
Ignition		Continuous	
Ignitor Gap (Inches)		.13/.15	
Weight (Pounds)			
Heater		18	
Shipping		24	
Size - L x W x H (Inches)			
Carton		28.25x12x17	
Product		26.25x9x15.5	

REPLACEMENT PARTS

⚠ WARNING: Use only original replacement parts. This heater must use design-specific parts. Do not substitute or use generic parts. Improper replacement parts could cause serious or fatal injuries. This will also protect your warranty coverage for parts replaced under warranty.

PARTS UNDER WARRANTY

Contact authorized dealers of this product. If they can't supply original replacement part(s), either contact your nearest Parts Central or call DESA International's Technical Service Department at 1-800-323-5190. When calling DESA International, have ready:

- your name
- your address
- model number of your heater
- how heater was malfunctioning
- purchase date

In most cases, we will ask you to return the defective part to the factory.

PARTS NOT UNDER WARRANTY

Contact authorized dealers of this product. If they can't supply original replacement part(s), either contact your nearest Parts Central or call DESA International's Parts Department at 1-800-972-7879 for referral information. When calling DESA International, have ready:

- model number of your heater
- the replacement part number

WIRING DIAGRAM

100,000 Btu/Hr Model

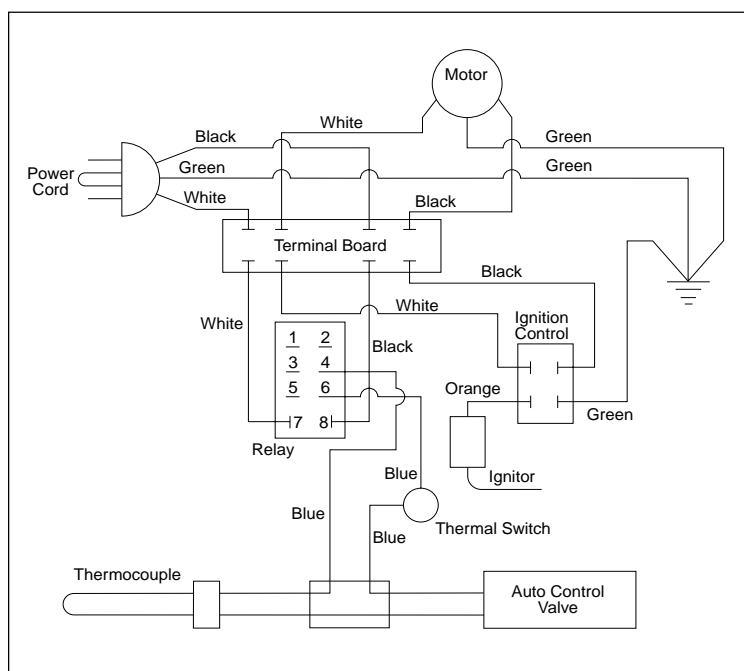

100,000 Btu/Hr PROPANE CONSTRUCTION HEATER

ILLUSTRATED PARTS BREAKDOWN

100,000 Btu/Hr

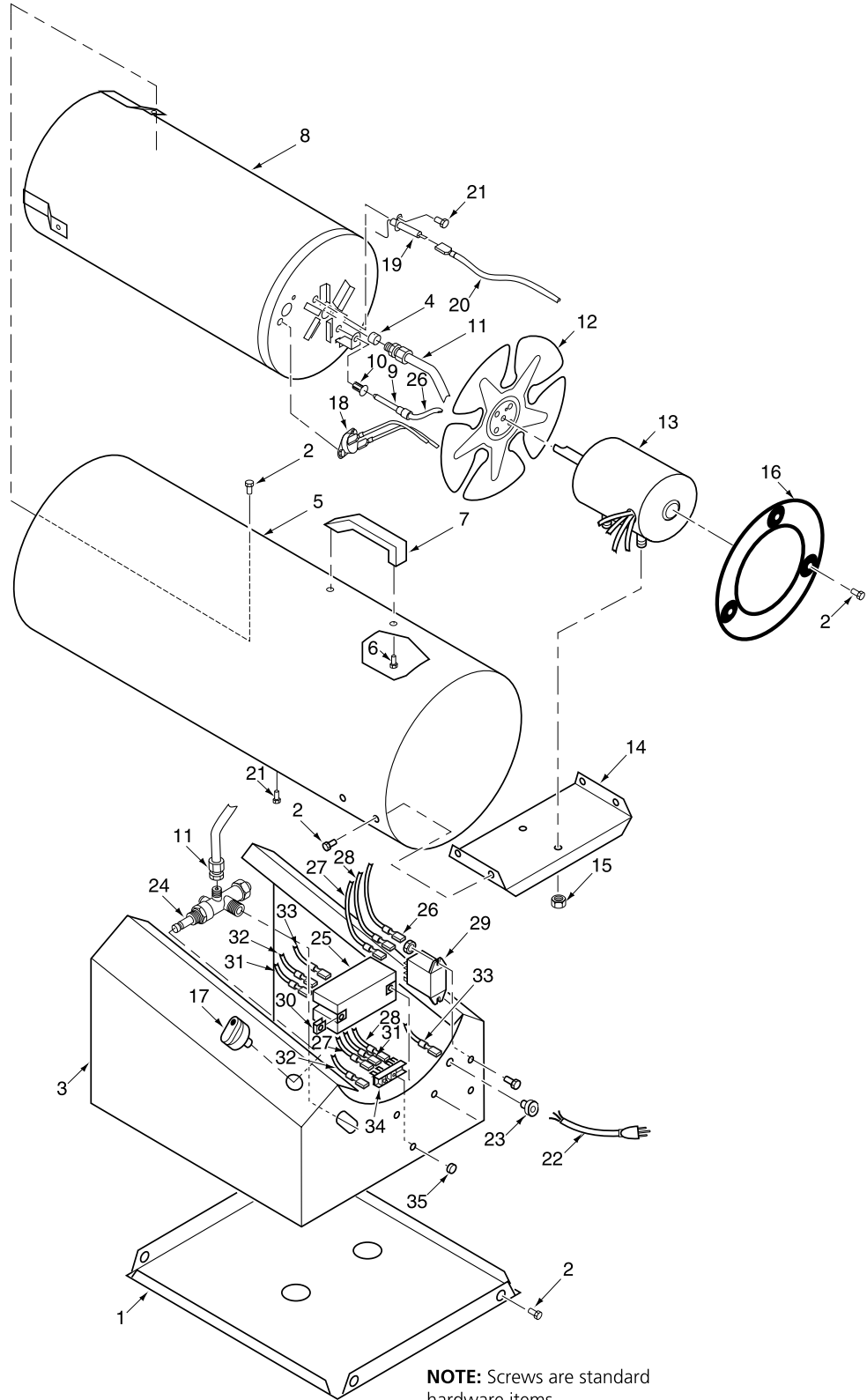

OWNER'S MANUAL

PARTS LIST

This list contains replaceable parts used in your heater. When ordering parts, follow the instructions listed under *Replacement Parts* on page 9 of this manual.

100,000 Btu/Hr

KEY NO.	PART NUMBER	DESCRIPTION	QTY.
1	102362-01	BaseTray	1
2	M11084-26	HexTPG Screw, 10-16X 38	15
3	103917-01AA	Base	1
4	099138-02	Nozzle	1
5	098511-215	Shell Kit (BLP100)	1
	098511-216	Shell Kit (REM100LP)	1
	098511-214	Shell Kit (RLP100)	1
6	M11084-29	Hex TPG Screw,10-16 X .75	2
7	M51104-01	Handle	1
8	098512-61	Combustion Chamber Kit	1
9	099538-01	Thermocouple	1
10	099237-01	Thermocouple Clip	1
11	099334-02	Fuel Tube Kit	1
12	M51153-01	Fan	1
13	102366-01	Motor	1
14	102380-01	Motor Bracket	1
15	NTC-4C	Hex Lock Nut, 1/4-20	2
16	102315-02	Fan Guard	1
17	099393-03	Control Knob	1
18	101732-04	Thermal Switch Kit (Incl. Wire Assemblies)	1
19	102487-01	Ignitor Electrode	1
20	097806-02	Ignitor Cable	1
21	M11084-38	Screw, Hex TPG, 8-18 X .38	2
22	098219-17	Power Cord	1
23	M11143-1	Strain Relief Bushing	1
24	103846-01	Valve Kit	1
25	102601-01	Ignition Control	1
26	079010-30	Wire Assembly (Relay)	1
27	079010-19	Wire Assembly (Relay)	1
28	097951-14	Wire Assembly (Relay)	1
29	103847-01	Relay Kit	1
30	102602-01	U-Clip Nut, #6 X .12	2
31	M9900-170	Wire Assembly (Ignition Control)	1
32	M16841-56	Wire Assembly (Ignition Control)	1
33	M16841-68	Wire Assembly (Ignition Control)	1
34	099125-11	Terminal Board	1
35	099157-01	Break Mandrel Rivet, 3/16	1
PARTS AVAILABLE—NOT SHOWN			
	102370-01	Owners Manual	1
	079231-01	Service Center List	1
	097940-06	Tradename Decal, BLP100	2
	097941-17	Tradename Decal, RLP100	2
	099596-09	Tradename Decal, REM100LP	1
	099596-10	Tradename Decal, REM100LP	1
	105350-01	Operation Decal	1
	105351-01	Warning Decal	1
	102599-01	Electrical Decal	1
	LPA3100	Regulator and Hose Assembly	1
	LPA1000	10' Hose Assembly	1
	LPA2150	Regulator	1
	LPA4020	Fuel Gas Connector	1

OWNER'S REGISTRATION FORM

Complete registration form and mail or complete on-line registration at www.desatech.com within 30 days after purchase.

Brand: _____ (Reddy Heater, Master, Remington, etc.)
 Model: _____ (R60, HD15, etc.)
 Date Purchased: _____ Note: Keep receipt for warranty verification.
 Serial Number: _____ 7 or 9 digit number located on product or identification tag.
 First Name: _____ Last Name: _____
 Address: _____
 City: _____ State: _____ Zip: _____ Country: _____
 Phone: (____) _____ - _____ E-Mail: _____

Please answer the following questions to register your product with DESA International:

1. Who will heater be used by? Individual Business
2. Will you use your heater in more than one location? Yes No
3. Where will the product be used? (You may select more than one.) Workshop Workshop Barn Residential Construction
 Commercial Construction Garage Factory Recreation Warehouse Utility Shed/Outbuilding
 Other _____ (Specify)
4. Cost of product (excluding sales tax)? \$ _____
5. Maintenance/service work will be performed by: Self Service Center Other _____
6. If you bought this product yourself, did you plan to purchase this type of product before going into the store? Yes No
7. Type of store where product was purchased? Hardware Propane Dealer Natural Gas/Utility Co. Home Center or Builder's Supply
 Farm/Ag. Supply Auto Parts Warehouse Club Industrial/Contractor Supply Rental Store
 Discount Store HVAC Dealer Other _____
8. What is your primary source of heat? Propane (LP Gas) Natural Gas Kerosene Diesel Electric Other _____
9. What motivated you to buy this product? Sudden Cold Weather Replace Older Model D.I.Y. Home Project Emergency Back-Up Heat
 Heater on Sale Construction Project Hard to Heat Location Other _____
10. How did you learn about this product brand? Advertisement Relative or Friend Co-Worker Store Representative
 Store Display Previously Owned a Heater Other _____ (Specify)
11. What other brands did you consider? None Master Remington All-Pro Dayton Universal Mr. Heater L.B. White Tradesman
 John Deere Dyna-Glo Dura-Heat Paulin Coleman Vogelzang American Other _____
12. Who selected the product? Male Female Both
13. Level of Education of Purchaser: High School Vocation/Technical School Some College Completed College Graduate School
14. Age of Purchaser: Under 20 20 - 29 30 - 39 40 - 49 50 - 59 60 or Over
15. Buyer's total annual household income: Under \$19,999 \$20,000 to \$34,999 \$35,000 to \$49,999
 \$50,000 to \$74,999 \$75,000 to \$99,999 \$100,000 and Over
16. What is the population of your area? Under 10,000 10,000 to 25,000 25,000 to 50,000 50,000 to 100,000
 100,000 to 250,000 Over 250,000
17. Store where product was purchased:
 Name: _____ City: _____ State: _____
18. In choosing this product, how important were the following:

	Not	Somewhat	Very		Not	Somewhat	Very
Availability	<input type="radio"/>	<input type="radio"/>	<input type="radio"/>	Size	<input type="radio"/>	<input type="radio"/>	<input type="radio"/>
Price	<input type="radio"/>	<input type="radio"/>	<input type="radio"/>	Prior Brand Experience	<input type="radio"/>	<input type="radio"/>	<input type="radio"/>
Brand Name	<input type="radio"/>	<input type="radio"/>	<input type="radio"/>	Built-In Thermostat	<input type="radio"/>	<input type="radio"/>	<input type="radio"/>
Overall Quality	<input type="radio"/>	<input type="radio"/>	<input type="radio"/>	Ease of Operation	<input type="radio"/>	<input type="radio"/>	<input type="radio"/>
Heat Output (Btu/Hr Rating)	<input type="radio"/>	<input type="radio"/>	<input type="radio"/>	Special Features	<input type="radio"/>	<input type="radio"/>	<input type="radio"/>
Variable Heat Output (Btu/Hr)	<input type="radio"/>	<input type="radio"/>	<input type="radio"/>	Salesperson's Recommendation	<input type="radio"/>	<input type="radio"/>	<input type="radio"/>
Made in USA	<input type="radio"/>	<input type="radio"/>	<input type="radio"/>	Friend/Relative's Recommendation	<input type="radio"/>	<input type="radio"/>	<input type="radio"/>
Warranty	<input type="radio"/>	<input type="radio"/>	<input type="radio"/>	Portability	<input type="radio"/>	<input type="radio"/>	<input type="radio"/>
Local Service	<input type="radio"/>	<input type="radio"/>	<input type="radio"/>	Quiet Operation	<input type="radio"/>	<input type="radio"/>	<input type="radio"/>
Value for Price	<input type="radio"/>	<input type="radio"/>	<input type="radio"/>				
19. This question will allow us to better understand the demographic profile of our customers. Which of the following best describes you? (not required)
 African American Asian American Mexican Puerto Rican Cuban Other Hispanic White Other _____

TAPE

Postage
Required

DESA[™]
INTERNATIONAL
2701 Industrial Drive
P.O. Box 90004
Bowling Green, KY 42102-9004

TAPE

OTHER OUTDOOR HEATING PRODUCTS

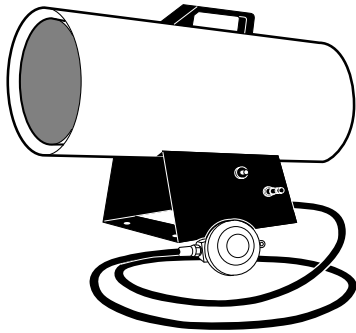

PROPANE/LP FORCED AIR HEATERS

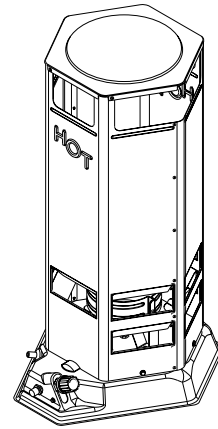

PROPANE/LP CONVECTION HEATERS

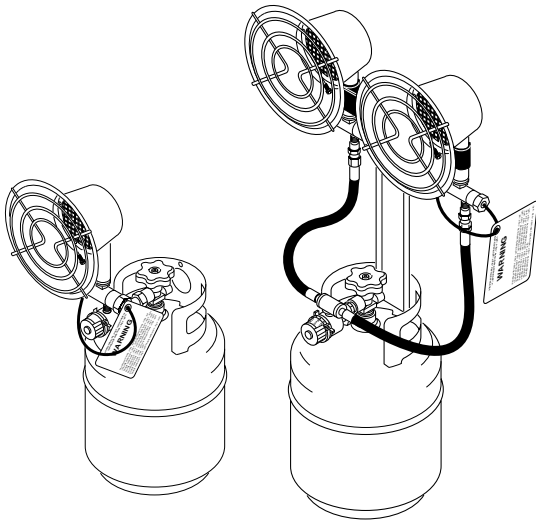

PROPANE/LP TANK TOP HEATERS

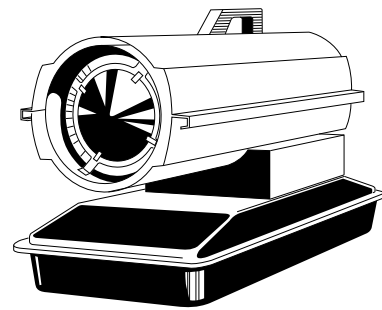

PORTABLE KEROSENE/DIESEL FORCED AIR HEATERS

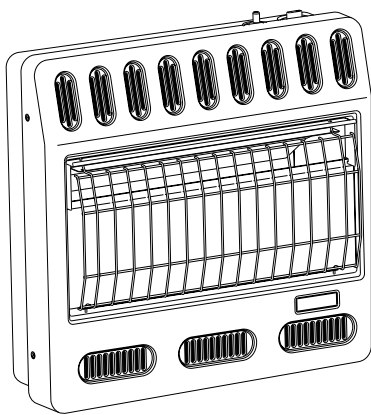

PROPANE/LP AND NATURAL GAS GARAGE HEATERS

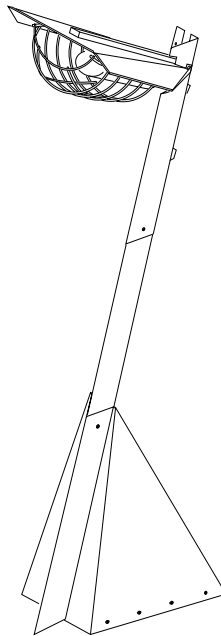

PROPANE/LP PATIO HEATERS



PROPANE/LP AND NATURAL GAS CHIMENEAS

WARRANTY AND REPAIR SERVICE

KEEP THIS WARRANTY

LIMITED WARRANTY

DESA International warrants this product and any parts thereof, to be free from defects in materials and workmanship for one (1) year from the date of first purchase when operated and maintained in accordance with instructions. This warranty is extended only to the original retail purchaser, when proof of purchase is provided.

This warranty covers only the cost of parts and labor required to restore the product to proper operating condition. Transportation and incidental costs associated with warranty repairs are not reimbursable under this warranty.

Warranty service is available only through authorized dealers and service centers.

This warranty does not cover defects resulting from misuse, abuse, negligence, accidents, lack of proper maintenance, normal wear, alteration, modification, tampering, contaminated fuels, repair using improper parts, or repair by anyone other than an authorized dealer or service center. Routine maintenance is the responsibility of the owner.

THIS EXPRESS WARRANTY IS GIVEN IN LIEU OF ANY OTHER WARRANTY EITHER EXPRESSED OR IMPLIED, INCLUDING WARRANTIES OF MERCHANTABILITY AND FITNESS FOR A PARTICULAR PURPOSE.

DESA International assumes no responsibility for indirect, incidental or consequential damages. Some states do not allow the exclusion or limitation of incidental or consequential damages, or limitations or exclusions may not apply to you. This Limited Warranty gives you specific legal rights and you may also have other rights which vary from state to state.

We reserve the right to amend these specifications at any time without notice. The only warranty applicable is our standard written warranty. We make no other warranty, expressed or implied.

WARRANTY SERVICE

Should your heater require service, return it to your nearest authorized service center. Proof of purchase must be presented with the heater. The heater will be inspected. A defect may be caused by faulty materials or workmanship. If so, DESA International will repair or replace the heater without charge.

REPAIR SERVICE

Return your heater to your nearest authorized service center. Repairs not covered by the warranty will be billed at standard prices. Each Service Center is independently owned and operated. We reserve the right to amend these specifications at any time without notice.

Model _____

Serial No. _____

Date of Purchase _____



2701 Industrial Drive
P.O. Box 90004
Bowling Green, KY 42102-9004

www.desatech.com



102370 01

NOT A UPC

For information, write: DESA International, P.O. Box 90004
Bowling Green, Kentucky 42102-9004 ATTN: Customer Service Department
When writing, always include model number and serial number.

102370-01
Rev. H
05/02