

PORTABLE FORCED AIR HEATERS

OWNER'S MANUAL



Heater Sizes:
35,000 50,000 55,000 Btu/Hr

IMPORTANT

Read and understand this manual before assembling, starting, or servicing heater. Improper use of heater can cause serious injury. Keep this manual for future reference.



CONTENTS

SECTION	PAGE
Safety Information	2
Product Identification	4
Unpacking	4
Theory of Operation	4
Fuels	5
Ventilation	5
Operation	5
Storing, Transporting, or Shipping	6
Preventative Maintenance Schedule	6
Troubleshooting	7
Service Procedures	8
Upper Shell Removal	8
Fan	8
Air Output, Air Intake, and Lint Filters	8
Pump Pressure Adjustment	9
Fuel Filter	9
Spark Plug	9
Nozzle	10
Pump Rotor	11
Wiring Diagram	11
Specifications	12
Technical Service	12
Replacement Parts	12
Maintenance Kits	13
Accessories	13
Illustrated Parts List	14
Warranty and Repair Service	Back Cover

SAFETY INFORMATION

WARNINGS

IMPORTANT: Read this Owner's Manual carefully and completely before trying to assemble, operate, or service this heater. Improper use of this heater can cause serious injury or death from burns, fire, explosion, electrical shock, and carbon monoxide poisoning.

DANGER

Carbon monoxide poisoning may lead to death!

Carbon Monoxide Poisoning: Early signs of carbon monoxide poisoning resemble the flu, with headaches, dizziness, and/or nausea. If you have these signs, the heater may not be working properly. **Get fresh air at once!** Have heater serviced. Some people are more affected by carbon monoxide than others. These include pregnant women, persons with heart or lung disease or anemia, those under the influence of alcohol, and those at high altitudes.

Make certain you read and understand all Warnings. Keep this manual for reference. It is your guide to safe and proper operation of this heater.

SAFETY INFORMATION

Continued

WARNINGS *(Continued)*

- Use only kerosene or No. 1 fuel oil to avoid risk of fire or explosion. Never use gasoline, naphtha, paint thinners, alcohol, or other highly flammable fuels.
- Fueling
 - a) Personnel involved with fueling shall be qualified and thoroughly familiar with the manufacturer's instructions and applicable federal, state, and local regulations regarding the safe fueling of heating units.
 - b) Only the type of fuel specified on the heater's data plate shall be used.
 - c) All flame, including the pilot light, if any, shall be extinguished and the heater allowed to cool, prior to fueling.
 - d) During fueling, all fuel lines and fuel-line connections shall be inspected for leaks. Any leaks shall be repaired prior to returning the heater to service.
 - e) At no time shall more than one day's supply of heater fuel be stored inside a building in the vicinity of the heater. Bulk fuel storage shall be outside the structure.
 - f) All fuel storage shall be located a minimum of 25 feet from heaters, torches, welding equipment, and similar sources of ignition (exception: the fuel reservoir integral with the heater unit).
 - g) Whenever possible, fuel storage shall be confined to areas where floor penetrations do not permit fuel to drip onto or be ignited by a fire at lower elevation.
 - h) Fuel storage shall be in accordance with the federal, state, or local authority having jurisdiction.
- Never use heater where gasoline, paint thinner, or other highly flammable vapors are present.
- Follow all local ordinances and codes when using heater.
- Heaters used in the vicinity of tarpaulins, canvas, or similar enclosure materials shall be located a safe distance from such materials. The recommended minimum safe distance is 10 feet. It is further recommended that these enclosure materials be of a fire retardant nature. These enclosure materials shall be securely fastened to prevent them from igniting or from upsetting the heater due to wind action.
- Use only in well-vented areas. Before using heater, provide at least a three-square-foot opening of fresh, outside air for each 100,000 Btu/Hr of rating. This heater produces carbon monoxide, which is listed by the State of California as a reproductive toxin under Proposition 65.
- Use only in places free of flammable vapors or high dust content.
- Use only the electrical voltage and frequency specified on model plate.
- Use only a three-prong, grounded extension cord.
- Minimum heater clearances from combustibles:
Outlet: 8 Ft. Sides: 4 Ft. Top: 4 Ft. Rear: 4 Ft.
- Locate heater on a stable and level surface if heater is hot or running or a fire may occur.
- When moving or storing heater, keep heater in a level position or fuel spillage may occur.
- Keep children and animals away from heater.
- Unplug heater when not in use.
- When used with thermostat, heater may start anytime.
- Never use heater in living or sleeping areas.
- Never block air inlet (rear) or air outlet (front) of heater.
- Never move, handle, refuel, or service a hot, operating, or plugged-in heater.
- Never attach duct work to front or rear of heater.

PRODUCT IDENTIFICATION

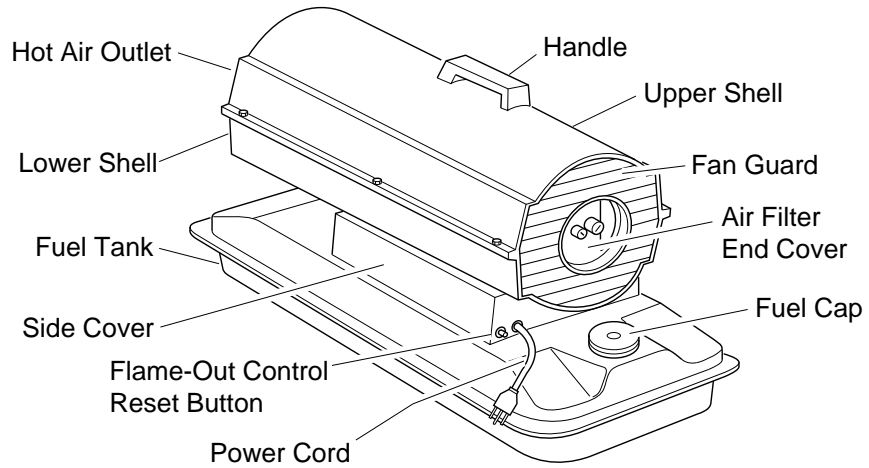

Figure 1

UNPACKING

1. Remove all packing items applied to heater for shipment.
2. Remove all items from carton.
3. Check items for shipping damage. If heater is damaged, promptly inform dealer where you bought heater.

THEORY OF OPERATION

The Fuel System: The air pump forces air through the air line. The air is then pushed through the burner head nozzle. This air causes fuel to lift from the tank. A fine mist of fuel is sprayed into the combustion chamber.

The Air System: The motor turns the fan. The fan pushes air into and around the combustion chamber. This air is heated and provides a stream of clean, hot air.

The Ignition System: The electronic ignitor sends voltage to the spark plug. The spark plug ignites the fuel and air mixture.

The Flame-Out Control System: This system causes the heater to shut down if the flame goes out.

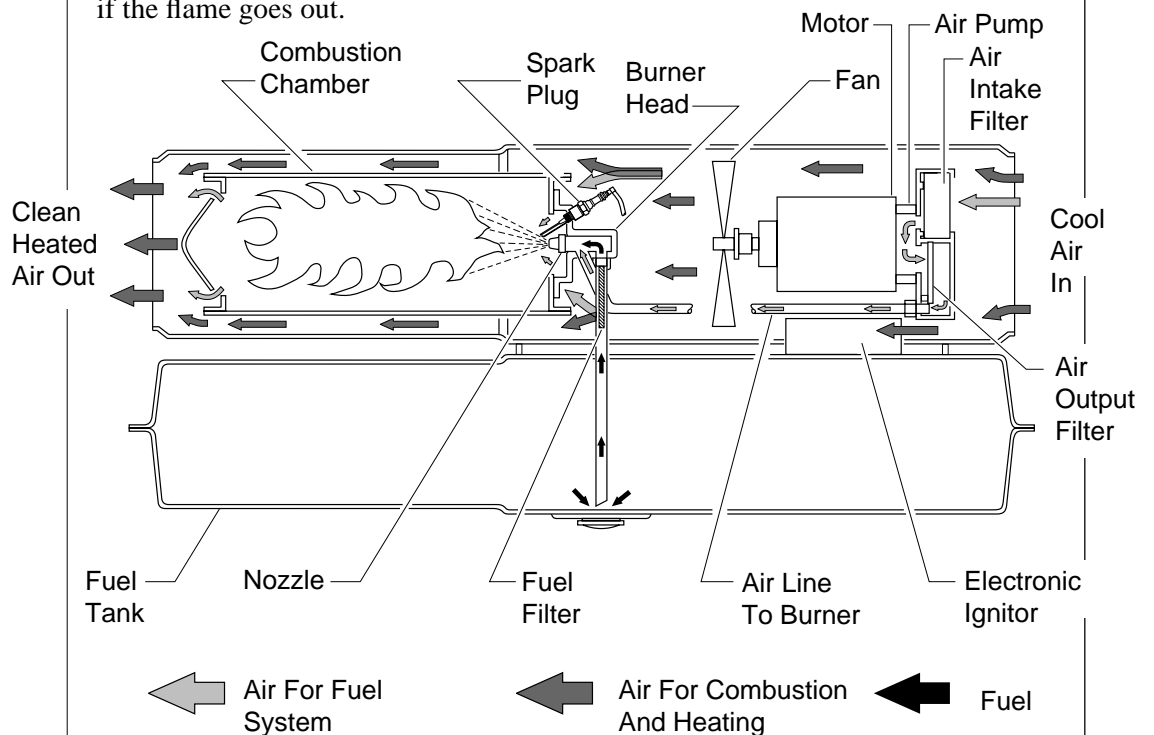

Figure 2 - Cross Section Operational View

FUELS

WARNING

Use only kerosene or No. 1 fuel oil to avoid risk of fire or explosion. Never use gasoline, naphtha, paint thinners, alcohol, or other highly flammable fuels.

Do not use heavy fuels such as No. 2 fuel oil or No. 2 Diesel. Using heavy fuels will result in:

- clogged fuel filter and nozzle
- carbon build up on spark plug
- the need of non-toxic anti-icer in fuel during very cold weather

IMPORTANT: Use a KEROSENE ONLY storage container. Be sure storage container is clean. Foreign matter such as rust, dirt, or water will cause the flame-out control to shut down heater. Foreign matter may also require you to clean fuel system often.

VENTILATION

WARNING

Follow the minimum fresh, outside air ventilation requirements. If proper fresh, outside air ventilation is not provided, carbon monoxide poisoning can occur. Provide proper fresh, outside air ventilation before running heater.

Provide at least a three-square-foot opening of fresh, outside air for each 100,000 Btu/Hr rating. Provide extra fresh air if more heaters are being used.

Example: A 55,000 Btu/Hr heater requires one of the following:

- a two-car garage door (16 feet wide opening) raised two inches
- a single-car garage door (9 feet wide opening) raised three inches
- two, windows (30 inches wide opening) raised five inches

OPERATION

WARNING

Review and understand the warnings in the Safety Information Section, pages 2 and 3. They are needed to safely operate this heater. Follow all local codes when using this heater.

To Start Heater

1. Follow all ventilation and safety information.
2. Fill fuel tank with kerosene or No. 1 fuel oil.
3. Attach fuel cap.
4. Plug power cord of heater into three-prong, grounded extension cord. Extension cord must be at least six feet long.

Extension Cord Wire Size Requirements

6 to 10 feet long, use 18 AWG rated cord

11 to 100 feet long, use 16 AWG rated cord

101 to 200 feet long, use 14 AWG rated cord

Continued

OPERATION

Continued

5. Plug extension cord into standard 120 volt/60 hertz, three-hole, grounded outlet. Heater will start when extension cord is plugged into outlet. If not, push in flame-out control reset button (see Figure 3).

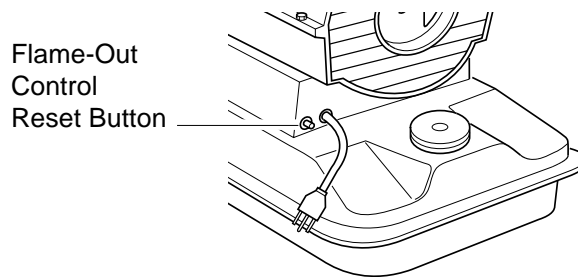

Figure 3 - Flame-Out Control Reset Button

To Stop Heater

1. Unplug extension cord from outlet.

To Restart Heater

1. Wait two minutes after stopping heater.
2. Repeat steps under *To Start Heater*, page 6.

Note: If shipping, transport companies require fuel tanks to be empty.

1. Drain fuel tank.

Note: Some models have drain plug on underside of fuel tank. If so, remove drain plug to drain all fuel. If heater does not have drain plug, drain fuel through fuel cap opening. Be sure all fuel is removed.

2. Replace drain plug if provided.
3. If any debris is noted in old fuel, add 1 or 2 quarts of clean kerosene to tank, stir, and drain again. This will prevent excess debris from clogging filters during future use.
4. Replace fuel cap or drain plug. Properly dispose of old and dirty fuel. Check with local automotive service stations that recycle oil.
5. If storing, store heater in dry place. Make sure storage place is free of dust and corrosive fumes.

IMPORTANT: Do not store kerosene over summer months for use during next heating season. Using old fuel could damage heater.

⚠ WARNING

Never service heater while it is plugged in, operating, or hot. Severe burns and electrical shock can occur.

PREVENTATIVE MAINTENANCE SCHEDULE

Item	How Often	How To
Fuel tank	Flush every 150-200 hours of operation or as needed.	See <i>Storing, Transporting, or Shipping</i> , above.
Air output and lint filters	Replace every 500 hours of operation or once a year.	See <i>Air Output, Air Intake, and Lint Filters</i> , page 9.
Air intake filter	Wash and dry with soap and water every 500 hours of operation or replace as needed.	See <i>Air Output, Air Intake, and Lint Filters</i> , page 9.

PREVENTATIVE MAINTENANCE SCHEDULE

Continued

TROUBLE- SHOOTING

Fuel filter	Clean twice a heating season or replace as needed.	See <i>Fuel Filter</i> , page 10.
Spark plug	Clean and regap every 600 hours operation or replace as needed.	See <i>Spark Plug</i> , pages 10 and 11.
Fan blades	Clean each season or as needed.	See <i>Fan</i> , page 9.
Motor	Not required/permanently lubricated	

WARNING

Never service heater while it is plugged in, operating, or hot. Severe burns and electrical shock can occur.

OBSERVED FAULT	POSSIBLE CAUSE	REMEDY
Heater ignites, but flame-out control shuts off heater after a short period of time.	Wrong pump pressure	See <i>Pump Pressure Adjustment</i> , page 10.
	Dirty air output, air intake and lint filters	See <i>Air Output, Air Intake and Lint Filters</i> , page 9.
	Dirty fuel filter	See <i>Fuel Filter</i> , page 10.
	Dirt in nozzle	See <i>Nozzle</i> , page 11.
	Dirty photocell lens	Clean photocell lens.
	Bad flame-out control	Replace flame-out control.
Heater will not ignite, but motor runs for a short period of time.	Wrong pump pressure	See <i>Pump Pressure Adjustment</i> , page 10.
	Carbon deposits on spark plug and/or improper gap	See <i>Spark Plug</i> , pages 10 and 11.
	Dirty fuel filter	See <i>Fuel Filter</i> , page 10.
	Dirt in nozzle	See <i>Nozzle</i> , page 11.
	Water in fuel tank	Drain and flush fuel tank with clean kerosene. See <i>Storing, Transporting, or Shipping</i> , page 7.

WARNING: High voltage!

Electronic ignitor not grounded	Make sure electronic ignitor mounting is tight.
Bad electronic ignitor	Replace electronic ignitor.

Motor does not start when heater is plugged in, fan rotates slowly or does not turn.	Flame-out control not reset	Press flame-out control reset button.
	Binding pump rotor	If fan is hard to turn, see <i>Pump Rotor</i> , page 12.

SERVICE PROCEDURES

Upper Shell Removal

1. Remove screws along each side of heater using 5/16" nut-driver. These screws attach upper and lower shells together.
2. Lift upper shell off.
3. Remove fan guard.

Fan

IMPORTANT: Remove fan from motor shaft before removing motor from heater. The weight of the motor resting on the fan could damage the fan pitch.

1. Remove upper shell (see above).
2. Use 1/8" allen wrench to loosen set-screw which holds fan to motor shaft.
3. Slip fan off motor shaft.
4. Clean fan using soft cloth moistened with kerosene or solvent.
5. Dry fan thoroughly.
6. Replace fan on motor shaft. Place fan hub flush with end of motor shaft (see Figure 5).
7. Place setscrew on flat of shaft. Tighten setscrew firmly (40-50 inch-pounds).
8. Replace fan guard and upper shell.

Air Output, Air Intake, and Lint Filters

1. Remove upper shell (see above).
2. Remove filter end cover screws using 5/16" nut-driver.
3. Remove filter end cover.
4. Replace air output and lint filters.
5. Wash or replace air intake filter (see Preventative Maintenance Schedule, page 7).
6. Replace filter end cover.
7. Replace fan guard and upper shell.

IMPORTANT: Do not oil filters.

⚠ WARNING

Never service heater while it is plugged in, operating, or hot. Severe burns and electrical shock can occur.

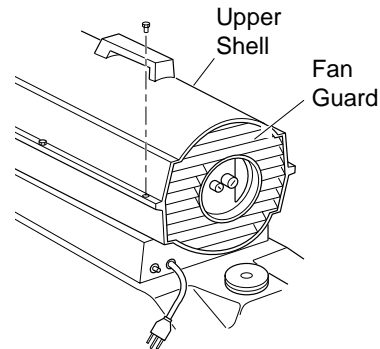

Figure 4 - Upper Shell Removal

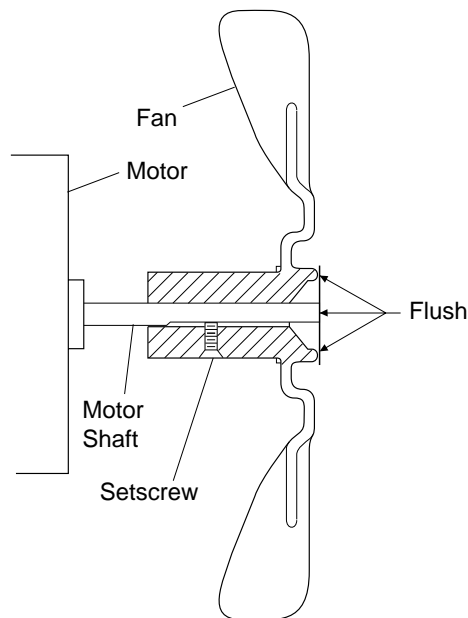

Figure 5 - Fan Cross Section

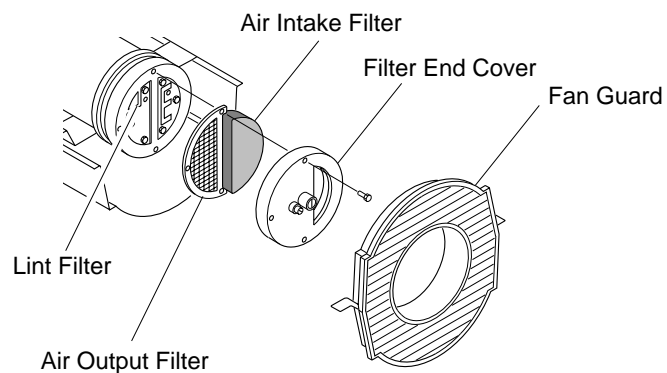

Figure 6 - Air Output, Air Intake, and Lint Filters

Pump Pressure Adjustment

1. Remove pressure gauge plug from filter end cover.
2. Install accessory pressure gauge (part number HA1180).
3. Start heater (see Operation, page 6). Allow motor to reach full speed.
4. Adjust pressure. Turn relief valve to right to increase pressure. Turn relief valve to left to decrease pressure. See specifications at right for correct pressure for each model.
5. Remove pressure gauge. Replace pressure gauge plug in filter end cover.

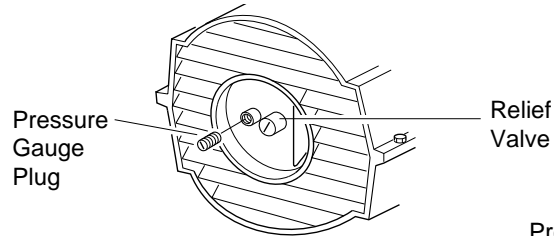

Figure 7 - Pressure Gauge Plug Removal

Model	Pump Pressure
35,000 Btu/Hr	3.0 PSI
50,000 Btu/Hr	3.4 PSI
55,000 Btu/Hr	3.4 PSI

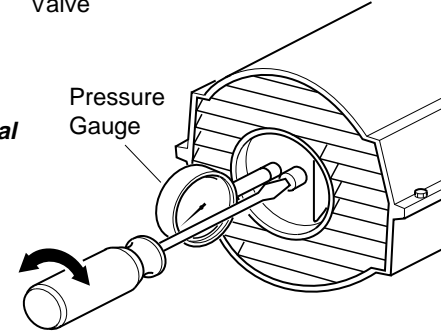

Figure 8 - Adjusting Pump Pressure

Fuel Filter

1. Remove side cover screws using 5/16" nut-driver.
2. Remove side cover.
3. Pull upper fuel line off fuel filter neck.
4. Carefully pry bushing and fuel filter out of fuel tank.
5. Wash fuel filter with clean fuel and replace in tank.
6. Attach upper fuel line to fuel filter neck.
7. Replace side cover.

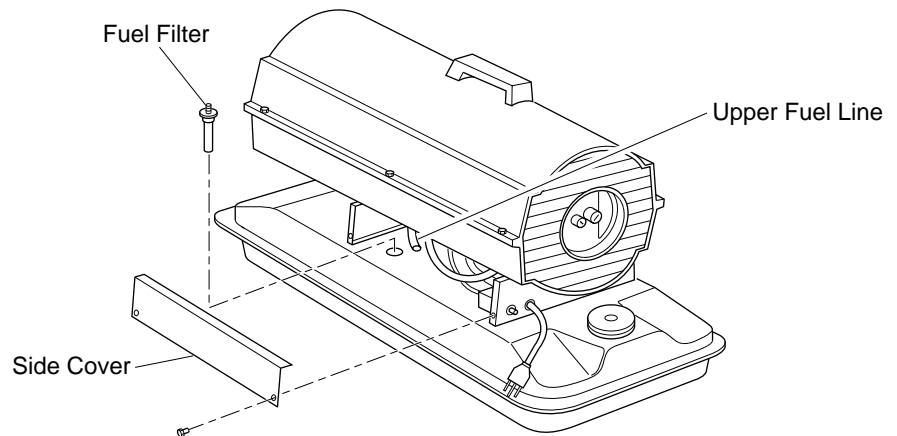

Figure 9 - Fuel Filter Removal

Spark Plug

1. Remove upper shell (see page 9).
2. Remove fan (see page 9).
3. Remove fuel and air line hoses from nozzle assembly.
4. Remove spark plug wire from spark plug.
5. Remove two screws using 5/16" nut-driver and remove burner strap.
6. Place hex-body of spark plug into vise and tighten.
7. Remove spark plug mounting nut using 11/16" open-end wrench.
8. Remove burner strap from spark plug.
9. Clean and regap spark plug electrodes to .055" gap.
10. Replace burner strap onto spark plug. Rotate burner strap to position spark plug electrodes (see Figure 12, page 11).

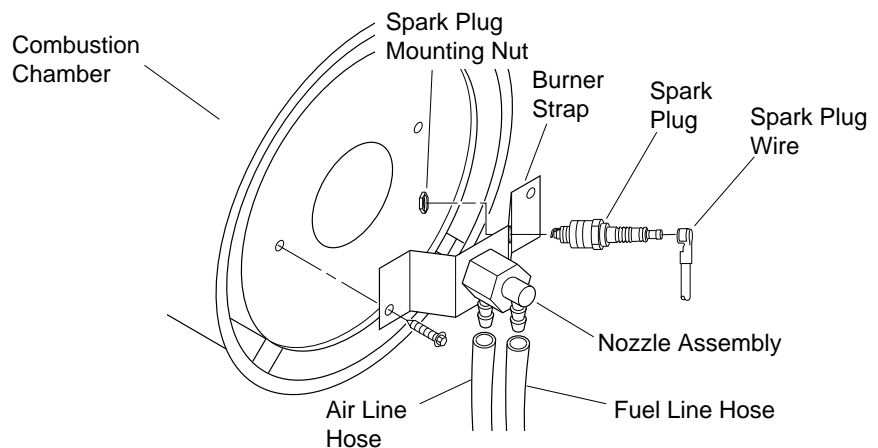

Figure 10 - Spark Plug Removal

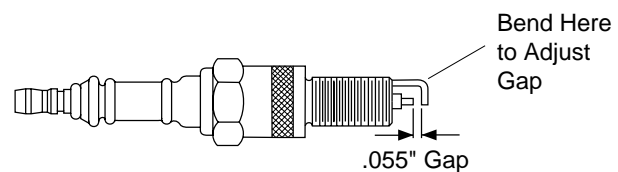

Figure 11 - Spark Plug Gap

Continued

11. Tighten spark plug with spark plug mounting nut.
12. Release hex-body of spark plug from vise.
13. Replace burner strap onto combustion chamber.
14. Attach spark plug wire to spark plug.
15. Attach fuel and air line hoses to nozzle assembly.
16. Replace fan (see page 9).
17. Replace fan guard and upper shell.

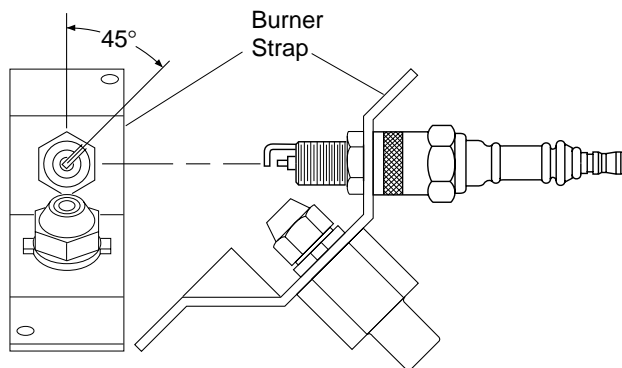

Figure 12- Spark Plug Rotation

Nozzle

1. Remove upper shell (see page 9).
2. Remove fan (see page 9).
3. Remove fuel and air line hoses from nozzle assembly.
4. Turn nozzle assembly 1/4 turn to left and pull toward motor to remove.
5. Place plastic hex-body into vise and lightly tighten.
6. Carefully remove nozzle from the nozzle adapter using 5/8" socket wrench.
7. Blow compressed air through face of nozzle. This will free any dirt in nozzle area.
8. Inspect nozzle seal for damage.
9. Replace nozzle into nozzle adapter until nozzle seats. Tighten 1/3 turn more using 5/8" socket wrench (40-45 inch-pounds).
10. Attach nozzle assembly to burner strap.
11. Attach fuel and airline hoses to nozzle assembly.
12. Replace fan (see page 9).
13. Replace fan guard and upper shell.

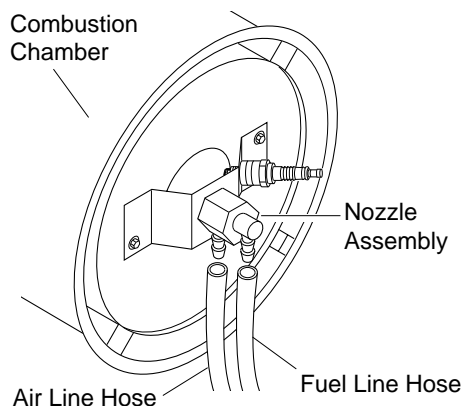

Figure 13 - Removing Air and Fuel Line Hoses

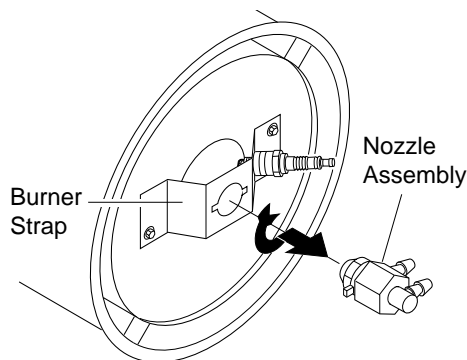

Figure 14 - Removing Nozzle Assembly

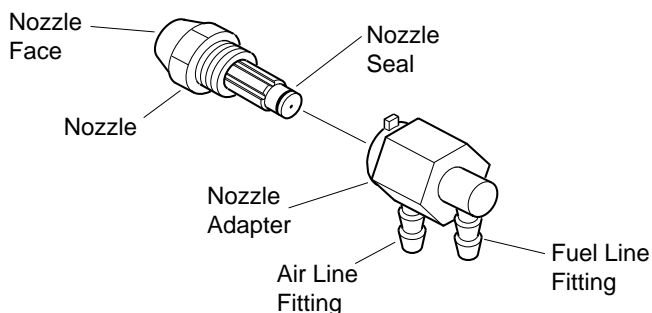

Figure 15 - Nozzle and Nozzle Adapter

Pump Rotor

(Procedure if rotor is binding)

1. Remove upper shell (see page 9).
2. Remove filter end cover screws using 5/16" nut-driver.
3. Remove filter end cover and air filters.
4. Remove pump plate screws using 5/16" nut-driver.
5. Remove pump plate.
6. Remove rotor, insert, and blades.
7. Check for debris in pump. If debris is found, blow out with compressed air.
8. Install insert and rotor.
9. Check gap on rotor. Adjust to .003"/.004" if needed (see Figure 17).

Note: Rotate rotor one full turn to insure the gap is .003"/.004" at tightest position. Adjust if needed.

10. Install blades, pump plate, air filters, and filter end cover.
11. Replace fan guard and upper shell.
12. Adjust pump pressure (see page 10).

Note: If rotor is still binding, proceed as follows.

13. Perform steps 1 through 6 (see above).
14. Place fine grade sandpaper (600 grit) on flat surface. Sand rotor lightly in "figure 8" motion four times (see Figure 18).
15. Reinstall insert and rotor.
16. Perform steps 10 through 12 above.

WIRING DIAGRAM

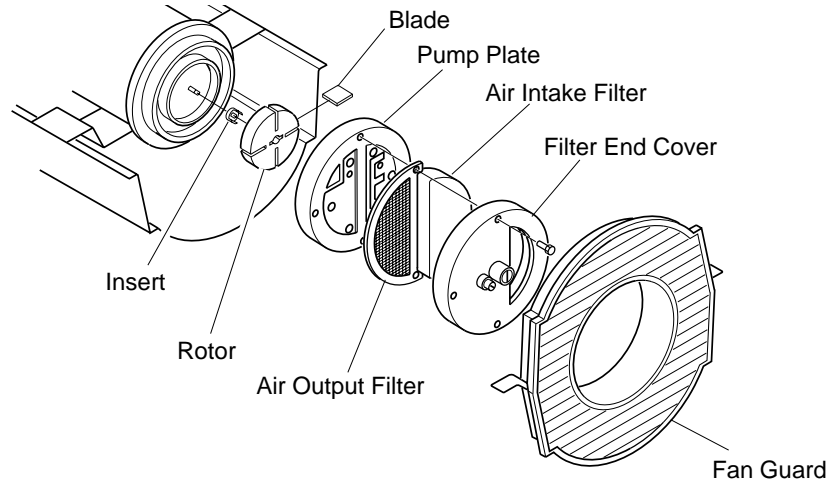

Figure 16 - Rotor Location

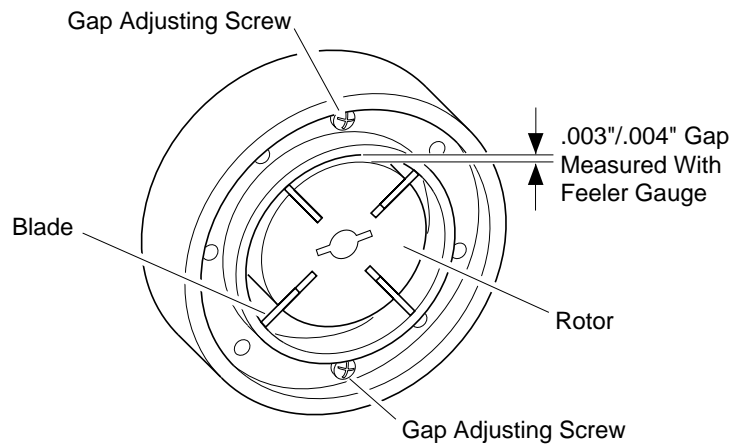

Figure 17 - Gap Adjusting Screw Locations

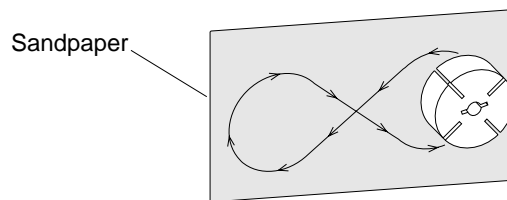

Figure 18 - Sanding Rotor

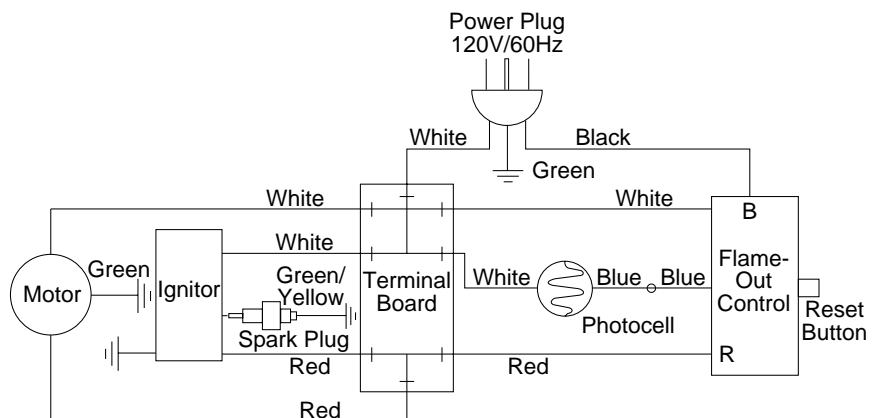

Figure 19 - Wiring Diagram

SPECIFICATIONS

Output Rating (Btu/Hr.)	35,000	50,000	55,000
Fuel	Use Only Kerosene or No. 1 Fuel Oil		
Fuel Tank Capacity (U.S. Gal.)	3.0	4.0	5.0
Fuel Consumption (Gal. Per Hr.)	.26	.40	.40
Electric Requirements	120 V/60 Hz (Same All Models)		
Amperage (Normal Run)	2.0	2.0	2.0
Hot Air Output (CFM)	165	175	175
Motor RPM	1725	1725	1725
Motor HP	1/15	1/15	1/15
Shipping Weight (Approximate Pounds)	34	35	36
Heater Weight without Fuel (Approximate Pounds)	29	30	31

TECHNICAL SERVICE

You may have further questions about installation, operation, or troubleshooting. If so, contact DESA International's Technical Service Department at 1-800-323-5190.

REPLACEMENT PARTS

Note: Use only original replacement parts. This will protect your warranty coverage for parts replaced under warranty.

Parts Under Warranty

Contact authorized dealer from whom you purchased this product. If they cannot supply original replacement part(s), call DESA International's Technical Service Department at 1-800-323-5190 for referral information.

When contacting your dealer or DESA International, have ready:

- your name
- your address
- model number of your heater
- how heater was malfunctioning
- purchase date

Usually, we will ask you to return the defective part to the factory.

Parts Not Under Warranty

Contact authorized dealers of this product. If they cannot supply original replacement part(s), call DESA International's Parts Department at 1-800-972-7879 for referral information.

When calling DESA International, have ready:

- model number of your heater
- the replacement part number

MAINTENANCE KITS

Btu/Hr	35,000	50,000	55,000
Flame-Out Control Part No.	HA3003	HA3003	HA3003
Spark Plug Part No.	HA3013	HA3013	HA3013
Filter Kit Part No.	HA3014	HA3014	HA3014
Nozzle Kit Part No.	HA3006	HA3021	HA3021
Rotor/Air Pump Kit Part No.	HA3004	HA3005	HA3005
Photocell Part No.	HA3019	HA3019	HA3019
Pump Adjustment Part No.	HA3020	HA3020	HA3020

ACCESSORIES

Purchase accessories and parts from your nearest dealer or service center. If they can not supply these accessories or parts, either contact your nearest Parts Central or DESA International for referral information. Parts Centrals are listed in the Authorized Service Center booklet supplied with heater.

DESA International
P.O. Box 90004
Bowling Green, KY
42102-9004
1-800-972-7879
Parts Department

AIR GAUGE KIT - HA1180

Special tool to check pump pressure.

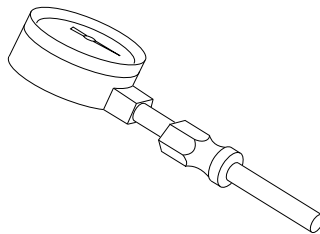

THERMOSTAT KIT - HA1210

Keeps your building at the temperature you select day and night. Helps economize on fuel.

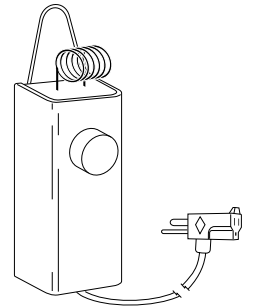

STANDARD WHEELS AND HANDLE KIT - HA1206

Makes heater even more portable and convenient. Easy to assemble.

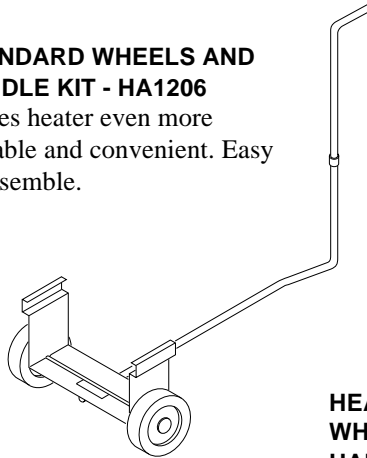

HEAVY DUTY WHEELS AND HANDLE KIT - HA1202

For heavy duty applications. Makes your heater even more portable and convenient.

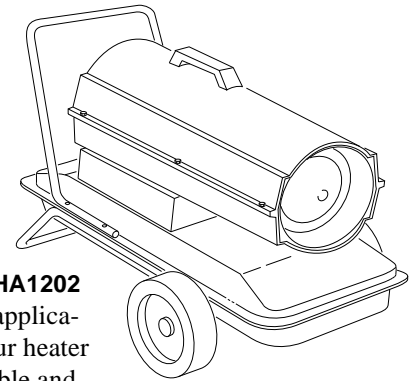

FLAME-OUT CONTROL/PHOTOCELL TESTER - HA1170

Special tool used to test the flame-out control and photocell.

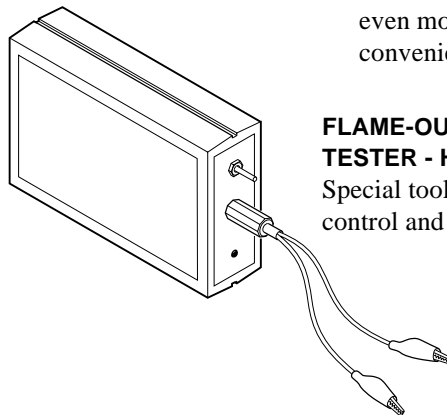

ILLUSTRATED PARTS BREAKDOWN

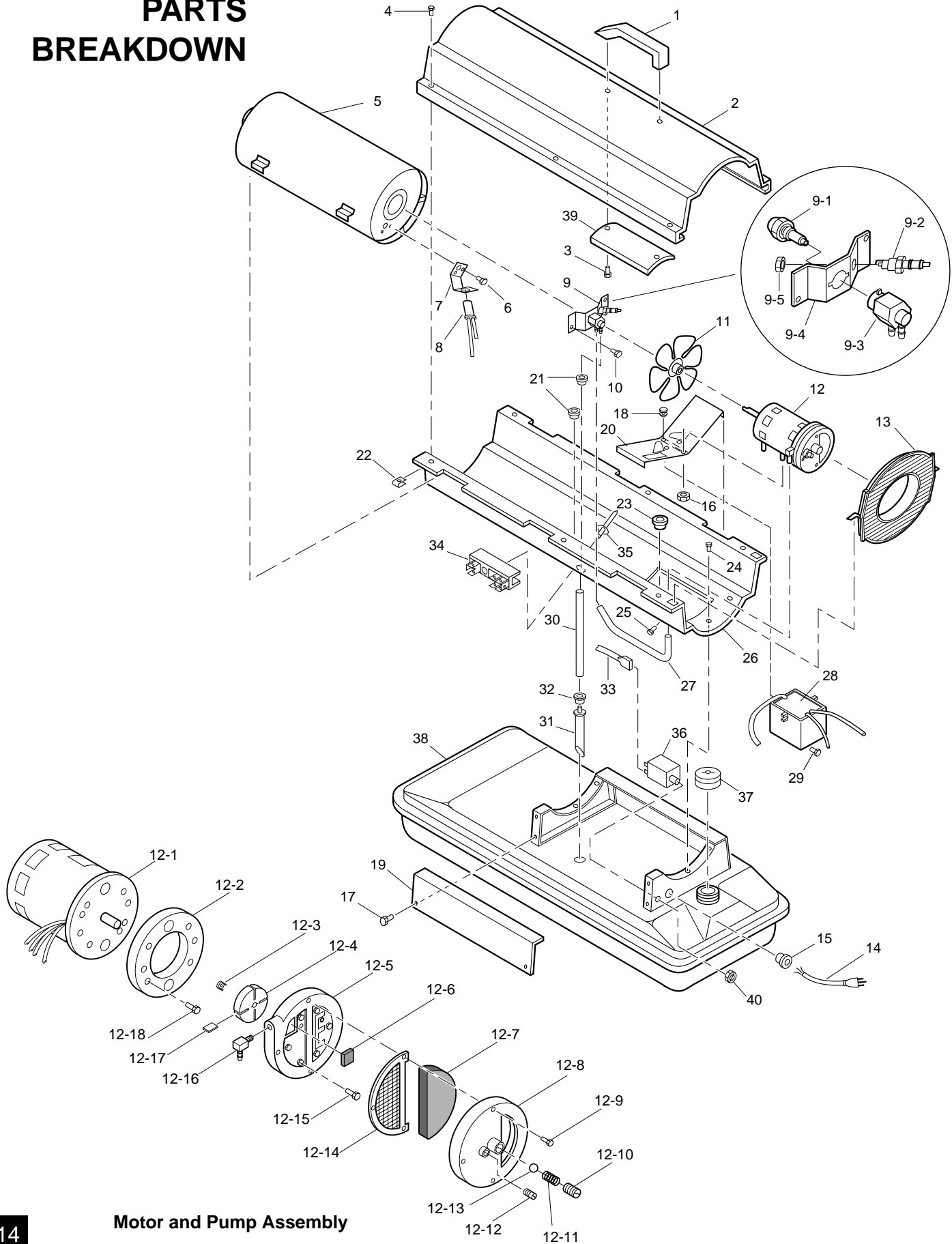

Motor and Pump Assembly

PARTS LIST

This list contains replaceable parts used in your heater. When ordering parts, be sure to provide the correct model and serial numbers (from the model plate), then the part number and description of the desired part.

KEY NO.	PART NUMBER	DESCRIPTION	QTY.	KEY NO.	PART NUMBER	DESCRIPTION	QTY.
1	M51104-01	Handle	1	20	101205-01	Motor Bracket	1
2	098511-36	Upper Shell (white)	1	21	M30865-02	Bushing	2
	098511-54	Upper Shell (yellow)	1	22	M11271-8	Clip Nut	6
	098511-67	Upper Shell (black)	1	23	M50104-02	Bushing	1
3	M11084-29	Screw, #10-16 x 3/4"	2	24	M11084-26	Screw, #10-16 x 3/8"	6
4	100647-01	Screw, #10-16 x 1/2"	6	25	M10908-14	Screw, #8-32 x 3/8"	1
5	098512-40	Combustion Chamber (35 model)	1	26	098511-18	Lower Shell (white)	1
	098512-32	Combustion Chamber (50/55 models)	1		098511-12	Lower Shell (yellow)	1
6	M10908-2	Screw, #6-32 x 3/8"	2		098511-81	Lower Shell (black)	1
7	M16660	Photocell Bracket	1	27	M29652-04	Rubber Airline	1
8	HA3019	Photocell Assembly	1	28	102482-01	Ignitor Kit	1
9	***	Burner Head Assembly	1	29	M11084-29	Screw, #10-16 x 3/4"	2
9-1	HA3006	Nozzle (35 model)	1	30	M29652-05	Fuel Line (35 model)	1
	HA3021	Nozzle (50/55 models)	1		079973-01	Fuel Line (50/55 models)	1
9-2	HA3013	Spark Plug	1	31	M50876-04	Fuel Filter (35 model)	1
9-3	079980-01	Nozzle Adapter	1		M50876-02	Fuel Filter (50 model)	1
9-4	097124-01	Bracket	1		M50876-05	Fuel Filter (55 model)	1
9-5	M29824	Nut, 14 mm	1	32	M10990-3	Rubber Bushing	1
10	M11084-26	Screw, #10-16 x 3/8"	2	33	M16841-57	Wire Assembly (Red, 6")	1
11	M30884	Fan	1	34	099125-02	Terminal Board	1
12	***	Motor and Pump Assembly	1	35	099157-01	Rivet	1
12-1	102001-01	Motor	1	36	HA3003	Flame-Out Control	1
12-2	079975-02	Pump Body (35 model)	1	37	097702-01	Fuel Cap (Includes Gasket)	1
	079975-03	Pump Body (50/55 models)	1	38	098513-23	Fuel Tank (35 model)	1
12-3	M22009**	Insert	1		098513-27	Fuel Tank (50 model)	1
12-4	M22456-1	Rotor (35 model)	1		098513-24	Fuel Tank (55 model)	1
	M22456-2**	Rotor (50/55 models)	1	39	M51108-01	Shell Heat-Shield	1
12-5	M29608	Pump End Cover	1	40	099177-01	Hex Nut	1
12-6	M29632**	Lint Filter	1	PARTS AVAILABLE - NOT SHOWN			
12-7	M29633**	Intake Filter	1		097204-01	Tradename Decal (R35B)	2
12-8	M29609	Filter End Cover	1		097204-08	Tradename Decal (R55)	2
12-9	M12461-31	Screw, #10-32 x 1"	3		097764-01	Tradename Decal (REM35A)	2
12-10	M27694**	Adjusting Screw	1		097764-02	Tradename Decal (REM50B)	2
12-11	M10993-1**	Pressure Relief Spring	1		097764-05	Tradename Decal (REM55)	2
12-12	M22997**	Plug	1		097646-01	Tradename Decal (B50G)	2
12-13	M8940**	Steel Ball, 1/4" Diameter	1		098493-01	General Information Decal	1
12-14	M29612-01**	Output Filter	1		M9900-192	Combustion Chamber Grounding Wire	1
12-15	M12461-31	Screw, #10-32 x 1"	6	OPTIONAL ACCESSORIES			
12-16	M50016	Elbow, 90°	1		HA1210	Hang-up Thermostat	
12-17	M8643	Blade (35 model)	4		HA1202	Heavy Duty Wheels and Handle Kit	
	M8643-2**	Blade (50/55 models)	4		HA1206	Standard Wheels and Handle Kit	
12-18	FHPF3-5C	Screw, #10-32 x 5/8" (35 model)	2		HA1180	Air Gauge Kit	
	FHPF3-6C	Screw, #10-32 x 3/4" (50/55 models)	2		HA2210	Fuel Tank Filter Screen	
13	M51105-01	Fan Guard	1		HA3005	Rotor Kit (M22456-2, M22009, M8643-2)	
14	098219-18	Power Cord	1		HA3014	Filter Kit (M29623, M29633, M29612-01)	
15	M11143-1	Strain Relief Bushing	1		HA3020	Pump Kit (M27694, M10993-1, M22997, M8940)	
16	NTC-4C	Hex Lock Nut, 1/4-20	2				
17	M11084-26	Screw, #10-16 x 3/8"	2				
18	M50631	Rubber Bumper	2				
19	M50899-03AA	Side Cover	1				

** See OPTIONAL ACCESSORIES

*** Not available as an assembly.

WARRANTY AND REPAIR SERVICE

LIMITED WARRANTY

DESA International warrants this product and any parts thereof, to be free from defects in materials and workmanship for one (1) year from the date of first purchase when operated and maintained in accordance with instructions. This warranty is extended only to the original retail purchaser, when proof of purchase is provided.

This warranty covers only the cost of parts and labor required to restore the product to proper operating condition. Transportation and incidental costs associated with warranty repairs are not reimbursable under this warranty.

Warranty service is available only through authorized dealers and service centers.

This warranty does not cover defects resulting from misuse, abuse, negligence, accidents, lack of proper maintenance, normal wear, alteration, modification, tampering, contaminated fuels, repair using improper parts, or repair by anyone other than an authorized dealer or service center. Routine maintenance is the responsibility of the owner.

THIS EXPRESS WARRANTY IS GIVEN IN LIEU OF ANY OTHER WARRANTY EITHER EXPRESSED OR IMPLIED, INCLUDING WARRANTIES OF MERCHANTABILITY AND FITNESS FOR A PARTICULAR PURPOSE.

DESA International assumes no responsibility for indirect, incidental or consequential damages. Some states do not allow the exclusion or limitation of incidental or consequential damages or limitations or exclusions may not apply to you. This Limited Warranty gives you specific legal rights and you may also have other rights which vary from state to state.

WARRANTY SERVICE

Should your heater require service, return it to your nearest authorized service center. Proof of purchase must be presented with the heater. The heater will be inspected. A defect may be caused by faulty materials or workmanship. If so, DESA International will repair or replace the heater without charge.

REPAIR SERVICE

Return the heater to your nearest authorized service center. Repairs not covered by the warranty will be billed at standard prices.

Illustrated parts lists can be obtained free of charge. Send a self addressed stamped envelope to the address listed below. List the heater model number and the date located in the lower right corner of this page. A service manual may be purchased from the address listed below. Send a check for \$5.00 payable to DESA International.

When writing for information regarding your heater, be sure to include the model number and serial number as shown on the model plate.

Each Service Center is independently owned and operated. We reserve the right to amend these specifications at any time without notice.

KEEP THIS WARRANTY

Model No.	_____
Serial No.	_____
Date of Purchase	_____

(To be filled in by purchaser)

DESA

INTERNATIONAL

Corporate Headquarters

2701 Industrial Drive

P.O. Box 90004

Bowling Green, KY 42102-9004

For information, write: DESA International, P.O. Box 90004
Bowling Green, Kentucky 42102-9004 ATTN: Customer Service Department
When writing, always include model number and serial number.

102437-01
Rev. C
01/97