



KEROSENE HIGH PRESSURE PORTABLE FORCED AIR HEATERS OWNER'S MANUAL

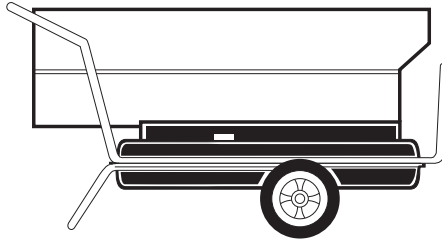
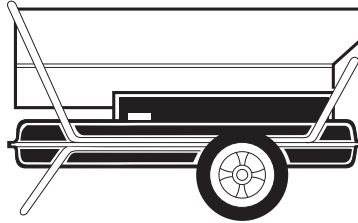

TABLE OF CONTENTS

Safety Information	2	Troubleshooting	7
Product Identification	3	Service Procedures	10
Unpacking	3	Illustrated Parts Breakdown and Parts List	14
Operation	3	Specifications	21
Fuels	4	Wiring Diagram	21
Ventilation	4	Maintenance Kits	22
Operation	4	Technical Service	22
Storing, Transporting of Shipping	5	Accessory	22
Operation with Portable Generator	6	Replacement Parts	22
Preventative Maintenance Schedule	6	Warranty and Repair Services.....	Back Cover

Fill In For Your Records

Model No. _____

(Located on side panel)

Serial No. _____

(Located on fuel tank)

Date of Purchase: _____

**Save this manual for future reference.
For more information, visit www.desatech.com**

SAFETY INFORMATION

IMPORTANT: Read this owner's manual carefully and completely before trying to assemble, operate or service this heater. Improper use of this heater can cause serious injury or death from burns, fire, explosion, electrical shock and carbon monoxide poisoning.

⚠ WARNING: This product contains and/or generates chemicals known to the State of California to cause cancer or birth defects or other reproductive harm.

⚠ DANGER: Carbon monoxide poisoning may lead to death!

Carbon Monoxide Poisoning: Early signs of carbon monoxide poisoning resemble the flu, with headaches, dizziness and/or nausea. If you have these signs, the heater may not be working properly. **Get fresh air at once!** Have heater serviced. Some people are more affected by carbon monoxide than others. These include pregnant women, persons with heart or lung disease or anemia, those under the influence of alcohol and those at high altitudes.

Make certain you read and understand all warnings. Keep this manual for reference. It is your guide to safe and proper operation of this heater.

1. Use only kerosene, #1#2 diesel/fuel oil, JET A or JP-8 fuels to avoid risk of fire or explosion. Never use gasoline, naphtha, paint thinners, alcohol or other highly flammable fuels.
2. Fueling
 - a) Personnel involved with fueling shall be qualified and thoroughly familiar with the manufacturer's instructions and applicable federal, state and local regulations regarding the safe fueling of heating units.
 - b) Only the type of fuel specified on the heater's data plate shall be used.
 - c) All flame, including the pilot light, if any, shall be extinguished and the heater allowed to cool, prior to fueling.
 - d) During fueling, all fuel lines and fuel-line connections shall be inspected for leaks. Any leaks shall be repaired prior to returning the heater to service.
3. Never use heater where gasoline, paint thinner or other highly flammable vapors are present.
4. Follow all local ordinances and codes when using heater.
5. Heaters used in the vicinity of tarpaulins, canvas or similar enclosure materials shall be located a safe distance from such materials. The recommended minimum safe distance is 10 feet. It is further recommended that these enclosure materials be of a fire retardant nature. These enclosure materials shall be securely fastened to prevent them from igniting or from upsetting the heater due to wind action.
6. Use only in well vented areas. Before using heater, provide at least a three-square-foot opening of fresh, outside air for each 100,000 Btu/Hr of rating.
7. Use only in places free of flammable vapors or high dust content.
8. Use only with the electrical voltage and frequency specified on model plate.
9. Heater must be grounded. Use only a properly grounded three-wire extension cord. Plug into grounded outlet only.
10. Minimum heater clearances from combustibles:
Outlet: 8 Ft. Sides: 4 Ft.
Top: 4 Ft. Rear: 4 Ft.
11. Locate heater on a stable and level surface while hot or running or a fire may occur.
12. When moving or storing heater, keep heater in a level position or fuel spillage may occur.
13. Keep children and animals away from heater.
14. Never start heater when combustion chamber is hot or if fuel has accumulated in combustion chamber.
15. Unplug heater when not in use.
16. This heater has a built-in thermostat. Plugged-in heater may start at anytime.
- e) At no time shall more than one day's supply of heater fuel be stored inside a building in the vicinity of the heater. Bulk fuel storage shall be outside the structure.
- f) All fuel storage shall be located a minimum of 25 feet from heaters, torches, welding equipment and similar sources of ignition (exception: the fuel reservoir integral with the heater unit).
- g) Whenever possible, fuel storage shall be confined to areas where floor penetrations do not permit fuel to drip onto or be ignited by a fire at lower elevation.
- h) Fuel storage shall be in accordance with the federal, state or local authority having jurisdiction.

SAFETY INFORMATION

Continued

- Never use heater in living or sleeping areas.
- Never block air inlet (rear) or air outlet (front) of heater.
- Never move, handle, refuel or service a hot, operating or plugged-in heater.
- Never attach duct work to front or rear of heater.
- Never use gasoline, crankcase drainings, naphtha, paint thinners, alcohol or other highly flammable fuels.
- Never leave a heater plugged in without adult supervision if children or animals are likely to be present.
- Warning to New York City Residents For Use Only At Construction Sites** in accordance with applicable NYC codes under NYCFD certificate of approval #4803, #4899, #4908, #4909 or #4934 or NYC Board of Standards and Appeals calendar number 62-59-5A.

PRODUCT IDENTIFICATION

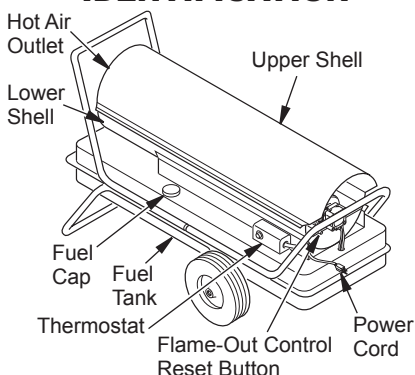

Figure 1 - 350,000 Btu/Hr Model

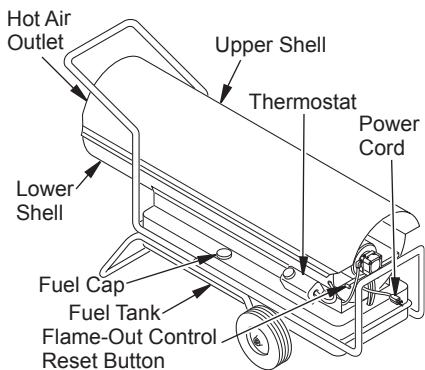

Figure 2 - 600,000 Btu/Hr Model

UNPACKING

- Remove all protective packing applied to heater for shipment.
- Remove heater from shipping container.
- Check heater for any shipping damage. If heater is damaged, promptly inform dealer where you bought heater.

OPERATION

The Fuel System: The motor turns the fuel pump. The fuel pump pulls fuel from the fuel tank. The fuel pump pushes fuel through a filter and a solenoid valve and out the burner head nozzle. A fine mist of fuel is sprayed into the combustion chamber.

The Air System: The motor turns the fan. The fan pushes air into and around the combustion chamber. This air is heated and provides a stream of clean, hot air.

The Ignition System: The electronic ignitor sends voltage to the spark plug. The spark plug ignites the fuel and air mixture.

The Flame-Out Control System: This system causes the heater to shut down if the flame goes out. It also allows the fan to continue running after normal shutdown of heater. This cools the combustion chamber.

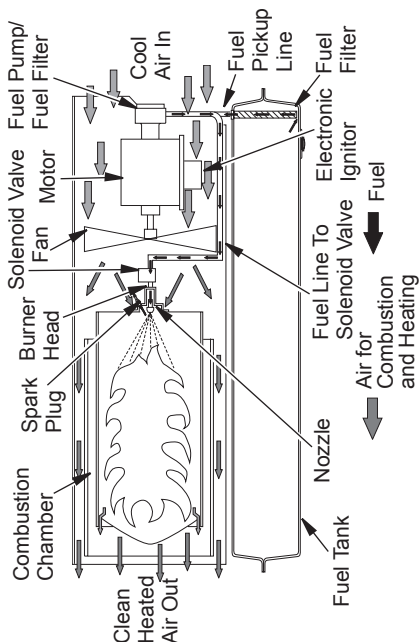

Figure 3 - Cross Section Operational View

FUELS

⚠ WARNING: Use only kerosene, #1#2 diesel/fuel oil, JET A or JP-8 fuels to avoid risk of fire or explosion. Never use gasoline, naphtha, paint thinners, alcohol or other highly flammable fuels.

Do not use heavy fuels such as No. 2 fuel oil or No. 2 diesel. Using heavy fuels will result in:

- clogged fuel filter and nozzle
- carbon build-up on spark plug
- the need of non-toxic anti-icer in fuel during very cold weather

IMPORTANT: Use a KEROSENE ONLY storage container. Be sure storage container is clean. Foreign matter such as rust, dirt or water will cause flame-out control to shut down heater. Foreign matter may also require you to clean fuel system often.

VENTILATION

⚠ WARNING: Follow the minimum fresh, outside air ventilation requirements. If proper fresh, outside air ventilation is not provided, carbon monoxide poisoning can occur. Provide proper fresh, outside air ventilation before running heater.

Fresh Air Opening Requirements

Heater Size	Square Feet Opening
350,000 Btu/Hr	10.5
600,000 Btu/Hr	18.0

Note: If you use more than one heater, provide extra fresh air. Provide a fresh air opening of at least three square feet for each 100,000 Btu/Hr rating.

OPERATION

⚠ WARNING: Review and understand the warnings in the Safety Information section, page 2. They are needed to safely operate this heater.

TO START HEATER

1. Follow all ventilation and safety information.
2. Locate heater to provide maximum circulation of the heated air. Follow all location requirements noted in *Safety Information*, page 2.
3. Fill fuel tank with kerosene, #1#2 diesel/fuel oil, JET A or JP-8 fuels.
4. Attach fuel cap.
5. Set thermostat dial to desired temperature. **Note:** Thermostat setting must be higher than surrounding air temperature.
6. Plug power cord of heater into three-prong, grounded extension cord. Extension cord must be at least six feet long.

⚠ WARNING: Use only a three-prong, grounded extension cord. Use cord with proper wire size to assure 120 volt operation. See Extension Cord Wire Size Requirements below.

Extension Cord Wire Size Requirements

- 6 to 100 feet long, use 14 AWG rated cord
 - 101 to 200 feet long, use 12 AWG rated cord
 - 201 to 300 feet long, use 10 AWG rated cord
 - 301 to 400 feet long, use 8 AWG rated cord
 - 401 to 500 feet long, use 6 AWG rated cord
7. Plug extension cord into standard 120 volt/60 hertz, three-hole, grounded outlet.
 8. The motor will start when extension cord is plugged into outlet. The heater should ignite at once. If heater does not ignite, restart heater. To restart heater, wait 60 seconds, then push in flame-out control reset button. Flame-out control reset button is at rear of heater near power cord (see Figure 4, page 5).

Note: A cold heater may affect the thermostat setting. This thermostat is a general-heating control. It is not intended for precise temperature control. Adjust thermostat until heater cycles at the desired setting.

Note: If starting heater for first time, you may need to prime the pump. If equipped, slightly open bleeder valve of pump to allow air to escape. Quickly close valve once fuel is seen. Wipe up any excess fuel. If equipped with canister fuel filter, remove the canister bottom and fill with fuel. Reassemble filter. Wipe up any excess fuel. You may also have to do this after taking heater out of storage.

OPERATION

Continued

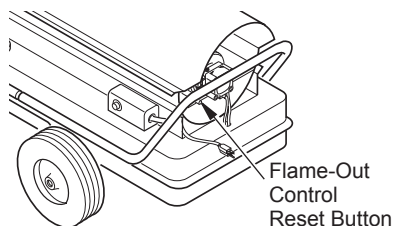

Figure 4 - Flame-Out Control Reset Button

TO STOP HEATER

CAUTION: Never unplug heater while heater is running. Heater must go through purge cycle. The purge cycle cools the combustion chamber. Damage to heater can occur if combustion chamber is not cooled. Do not restart heater until purge cycle is complete.

1. Turn thermostat dial to lowest temperature setting. This will cause heater flame to go out. The motor will continue to run during the purge cycle. This allows the fan to cool the combustion chamber. When the purge cycle is finished, the motor will stop. Do not unplug heater until purge cycle is finished.
2. Unplug extension cord from outlet.
3. To temporarily stop heater, set thermostat at a temperature lower than air around heater. Heater will cycle back on if air temperature around heater matches thermostat setting.

TO RESTART HEATER

CAUTION: Do not restart heater until purge cycle is finished. The purge cycle cools the combustion chamber.

1. Wait until purge cycle is finished after stopping heater.
2. Repeat steps under *To Start Heater*, page 4.

STORING, TRANSPORTING OF SHIPPING

Note: If shipping transport companies require fuel tanks to be empty.

1. Drain all fuel from fuel lines and pump/filter (see *Fuel Filters*, page 12).
 2. Clean and flush fuel filter in fuel pump if equipped (see *Fuel Filters*, page 12).
 3. Remove drain plug and drain fuel tank.
 4. Replace drain plug.
 5. If any debris is noted in old fuel, add 1 or 2 quarts of clean kerosene to tank, stir and drain again. This will prevent excess debris from clogging filters during future use.
 6. Replace fuel cap or drain plug. Properly dispose of old and dirty fuel. Check with local automotive service stations that recycle oil.
 7. Add two gallons (350,000 Btu/Hr) or three gallons (600,000 Btu/Hr) of clean kerosene, #1#2 diesel/fuel oil, JET A or JP-8 fuels to fuel tank.
 8. Replace fuel cap.
 9. Operate heater for 5 minutes (see *Operation*, page 4).
 10. Stop heater and let cool completely.
 11. Remove drain plug and drain fuel tank.
 12. Replace drain plug.
 13. Properly dispose of old and dirty fuel.
 14. If storing, store heater in a dry location. Make sure storage place is free of dust and corrosive fumes.
- IMPORTANT:** Do not store kerosene over summer months for use during next heating season. Using old fuel could damage heater.

OPERATION WITH PORTABLE GENERATOR

⚠ WARNING: Before operating heater or any appliance from a portable generator, verify that generator has been properly connected to earth ground. Improper grounding or failure to ground generator can result in electrocution if a ground fault occurs. Refer to owner's manual supplied by generator manufacturer for proper grounding procedures.

The operating voltage range of the heater is 108 to 132 Volts (120 Volts +/- 10%). Prior to plugging heater into generator the output voltage should be verified (if generator is equipped with the automatic idle feature, the output voltage should be measured with the generator running at full speed).

If the voltage does not measure in this range the heater should not be plugged into the generator. Refer to *Operation*, page 4, for starting, stopping and resetting heater procedures.

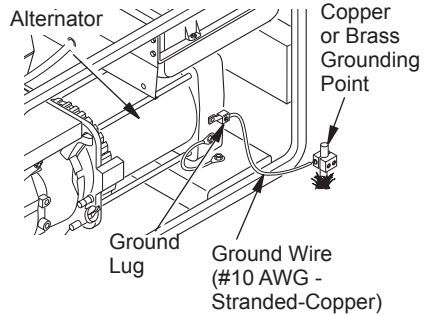

Figure 5 - Typical Generator Grounding Method (Generator construction may vary from that shown)

PREVENTATIVE MAINTENANCE SCHEDULE

⚠ WARNING: Never service heater while it is plugged in, operating or hot. Severe burns and electrical shock can occur.

Item	How Often	How To
Fuel tank	Flush every 150-200 hours of operation or as needed	See <i>Storing, Transporting, or Shipping</i> , page 5
Filler neck screen	Check for particles in fuel when filling fuel tank. Clean when dirty	Lift out of fuel tank and rinse with clean kerosene
Fuel filter assembly (Fuel tank)	Clean twice a heating season or replace as needed	See <i>Fuel Filters</i> , page 12
Fuel filter lines	Check and tighten loose connections occasionally	See <i>Fuel Lines</i> , Page 12
Fuel filter (In pump or external canister)	Clean fuel filter element every 250 hours	See <i>Fuel Filters</i> , page 12
Spark plug	Clean and regap every 300 hours of operation or replace as needed	See <i>Spark Plug</i> , page 10
Fan blades and air deflectors	Clean each season or as needed	See <i>Fan Blades and Air Deflectors</i> , page 10
Air passages around burner head	Check each season for dirt and debris	Remove debris and trash with a clean, soft cloth
Motor	Not required, permanently lubricated	

TROUBLESHOOTING

⚠ WARNING: Never service heater while it is plugged in, operating or hot. Severe burns and electrical shock can occur. Only a qualified service person should service and repair heater.

OBSERVED PROBLEM	POSSIBLE CAUSE	REMEDY
Motor does not start when heater is plugged in and thermostat setting is higher than surrounding air temperature	<ol style="list-style-type: none">No power or low voltage at heater due to:<ol style="list-style-type: none">Damaged power cord or extension cordWrong size extension cordHeater plugged into outlet with voltage lower than 120 voltLoose electrical connectionsMotor overload protector tripped due to:<ol style="list-style-type: none">Dirty fanDebris pulled into fan area by fanBinding pumpLow voltageFlame-out control not resetDamaged flame-out controlDamaged power relayDamaged thermostatBinding pump	<ol style="list-style-type: none"><ol style="list-style-type: none">Check condition of power cord or extension cord. Repair or replace if damagedUse extension cord with proper wire size (see <i>To Start Heater</i>, page 4)Make sure heater is plugged into 120 volt/60 hertz outletCheck connections. Tighten if loose<ol style="list-style-type: none">See <i>Fan Blades and Air Deflectors</i>, page 10Remove debris from fan and fan guard areaTurn fan by hand. If fan is hard to turn, see <i>Pump</i>, page 12See steps B and C under item 1 above<p>Note: Be sure to reset motor overload protector by pressing reset button on top of motor</p>Press and release flame-out control reset button. See Figure 4, page 4 for button locationReplace flame-out controlReplace power relayReplace thermostatTurn fan by hand. If fan is hard to turn, see <i>Pump</i>, page 12

TROUBLESHOOTING

Continued

OBSERVED PROBLEM	POSSIBLE CAUSE	REMEDY
Heater will not ignite, but motor runs for a short period of time.	1. A) Fuel tank empty B) Water in fuel C) Wrong fuel	1. A) Add fuel to tank B) Check fuel tank for bubbles of water in bottom. If found, remove fuel (see <i>Storing, Transporting, or Shipping</i> , page 5). Clean tank and fuel filters (see <i>Fuel Filters</i> , page 12). Fill with clean fuel C) Remove wrong fuel (see <i>Storing, Transporting, or Shipping</i> , page 5). Clean tank and fuel filters (see <i>Fuel Filters</i> , page 12). Fill with correct fuel
	2. Dirt in nozzle	2. Replace nozzle (see <i>Nozzle</i> , page 10)
	3. Very low temperature may cause fuel to thicken and not flow	3. Move heater to warmer place until fuel flows freely
	4. Dirty fuel filters	4. Clean fuel filters (see <i>Fuel Filters</i> , page 12)
	5. Wrong pump pressure	5. Adjust pump pressure (see <i>Pump Pressure Adjustment</i> sections, page 11)
	6. Spark plug wire disconnected from plug	6. Connect spark plug wire to spark plug
	7. Spark plug problems due to: A) Wrong gap B) Plug wet with fuel C) Carbon deposits on plug D) Damaged plug	7. A) Adjust electrode gap to .075" (see <i>Spark Plug</i> , page 10) B) Clean fuel from spark plug with clean, soft cloth C) Replace plug if heavily coated with carbon (see <i>Spark Plug</i> , page 10) D) Inspect plug for worn or eroded electrodes. If found, replace plug (see <i>Spark Plug</i> , page 10)
	8. Solenoid valve not opening	8. Check electrical connections and voltage to solenoid. If good, replace solenoid valve
		<div style="border: 1px solid black; padding: 5px; text-align: center;"> WARNING: High Voltage!</div>
	9. Damaged electronic ignitor	9. Replace electronic ignitor

TROUBLESHOOTING

Continued

OBSERVED PROBLEM	POSSIBLE CAUSE	REMEDY
Heater ignites, but flame-out control shuts off heater after a short period of time	1. Wrong pump pressure	1. Adjust pump pressure (see <i>Pump Pressure Adjustment</i> sections, page 11)
	2. Dirty fuel filters	2. Clean fuel filters (see <i>Fuel Filters</i> , page 12)
	3. Dirt in nozzle	3. Replace nozzle (see <i>Nozzle</i> , page 10)
	4. Dirty photocell lens	4. Clean photocell lens with clean cotton swab
	5. Open or damaged photocell	5. Replace photocell
	6. Bad flame-out control	6. Replace flame-out control
	7. Damaged fan switch	7. Replace fan switch
Heater burns, but puffs of smoke can be seen Heater does not burn steady Heater burns with odor Heater smokes continuously	1. Wrong pump pressure	1. Adjust pump pressure (see <i>Pump Pressure Adjustment</i> sections, page 11)
	2. A) Heater almost out of fuel B) Water condensation in fuel tank C) Wrong fuel	2. A) Add fuel to tank B) Check fuel tank for bubbles of water in bottom. If found, remove fuel (see <i>Storing, Transporting, or Shipping</i> , page 5). Clean tank and fuel filters (see <i>Fuel Filters</i> , page 12). Fill with clean fuel C) Remove wrong fuel (see <i>Storing, Transporting, or Shipping</i> , page 5). Clean tank and fuel filters (see <i>Fuel Filters</i> , page 12). Fill with correct fuel
	3. Dirty fuel filters	3. Clean fuel filters (see <i>Fuel Filters</i> , page 12)
	4. Air leak in suction system	4. Tighten all fuel line connections (see <i>Fuel Lines</i> , page 12)
	5. Dirty nozzle	5. Replace nozzle (see <i>Nozzle</i> , page 10)
	6. Low voltage causing motor to operate below rated speed	6. Check voltage at heater. Voltage at heater should be not less than 90% of rated voltage (108V minimum for 120V heaters)
	7. Loose fuel line	7. Check and tighten all fuel line connections (see <i>Fuel Lines</i> , page 12)

SERVICE PROCEDURES

⚠ WARNING: Never service heater while it is plugged in, operating or hot. Severe burns and electrical shock can occur. Only a qualified service person should service and repair heater.

UPPER SHELL REMOVAL

1. Remove screws along each side and top of heater using 5/16" nut-driver. These screws attach upper and lower shells together (see Figure 6).
2. Lift upper shell off.

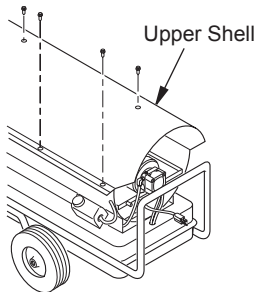

Figure 6 - Upper Shell Removal, 600,000 Btu/Hr Model

FAN BLADES AND AIR DEFLECTORS

1. Remove upper shell (see *Upper Shell Removal*).
2. Clean fan blades and air deflectors with clean, soft cloth moistened with kerosene or solvent (see Figure 7).
3. Dry fan blades and air deflectors thoroughly.
4. Replace upper shell.

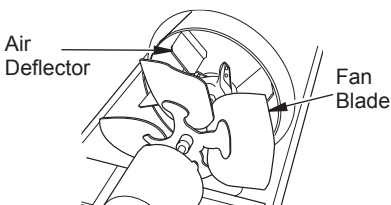

Figure 7 - Fan Blades and Air Deflectors

SPARK PLUG

1. Remove upper shell (see *Upper Shell Removal*).
2. Remove spark plug wire from spark plug (see Figure 8).
3. Remove spark plug from burner head using 13/16" open-end wrench (see Figure 8).
4. Replace spark plug if damaged or heavily coated with carbon.
5. Clean and regap spark plug electrodes to .075 inch (see Figure 9).
6. Install spark plug in burner head.
7. Attach spark plug wire to spark plug.
8. Replace upper shell.

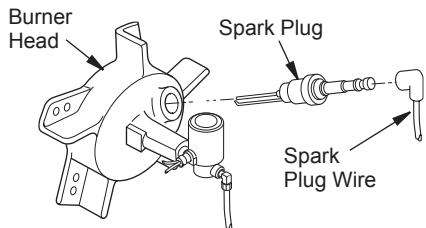

Figure 8 - Spark Plug Removal

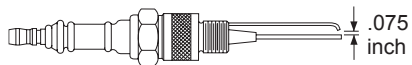

Figure 9 - Spark Plug Gap

NOZZLE

1. Remove upper shell (see *Upper Shell Removal*).
2. Remove fuel line from solenoid valve using 7/16" wrench.
3. Remove spark plug wire from spark plug.
4. Remove spark plug from burner head using 13/16" open-end wrench.
5. Remove five screws using 5/16" nut-driver and remove burner head from combustion chamber.
6. Place burner head into vise and lightly tighten.
7. Carefully remove nozzle from burner head using 5/8" socket wrench (see Figure 10).

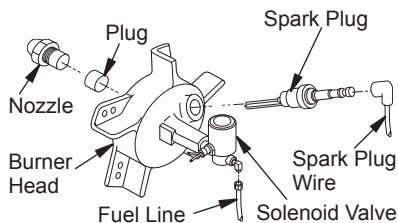

Figure 10 - Replacing Nozzle

SERVICE PROCEDURES

Continued

8. Inspect nozzle for damage. If damaged or clogged, replace nozzle.
9. Make sure plug is in place on burner head.
10. Replace nozzle into burner head and tighten firmly (175-200 inch-pounds).
11. Attach burner head to combustion chamber.
12. Install spark plug in burner head.
13. Attach spark plug wire to spark plug.
14. Attach fuel line to solenoid valve. Tighten firmly.
15. Replace upper shell.

PUMP PRESSURE ADJUSTMENT FOR HEATERS WITH FUEL FILTER/CANISTER EXTERNAL TO PUMP

1. Remove pressure gauge plug from fuel pump port marked "GAUGE."
2. Install accessory pressure gauge (part number 110380-01) to fuel pump port marked "GAUGE" (see Figure 11).
3. Start heater (see *Operation*, page 4). Allow motor to reach full speed.
4. Adjust pressure. Use small flat blade screwdriver to turn slotted screw at fuel pump pressure adjusting port. Turn screw clockwise to increase pressure. Turn screw counterclockwise to decrease pressure. See specifications in Figure 11 for correct pressure for each model.
5. Stop heater (see page 5).
6. Remove pressure gauge. Replace pressure gauge plug in fuel pump port marked "GAUGE."

Model	Pump Pressure
350,000 Btu/Hr	100 PSI
600,000 Btu/Hr	110 PSI

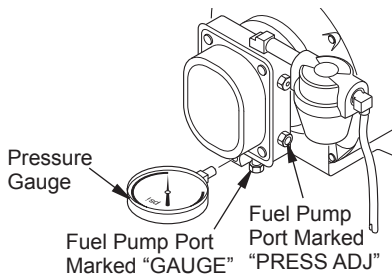

Figure 11 - Adjusting Pump Pressure

PUMP PRESSURE ADJUSTMENT FOR HEATERS WITH FUEL FILTER INTERNAL TO PUMP

1. Remove pressure gauge plug from fuel pump port marked "GAUGE."
2. Install accessory pressure gauge (part number 110380-01) to fuel pump port marked "GAUGE" (see Figure 12). Do not use bleeder valve port to check the pressure. The bleeder valve port contains pressure higher than operating pressure. Setting pump pressure with gauge in the bleeder valve port results in wrong operating pressure.
3. Start heater (see *Operation*, page 4). Allow motor to reach full speed.
4. Adjust pressure. Use small flat blade screwdriver to turn slotted screw at fuel pump port at top right side of pump. Turn screw clockwise to increase pressure. Turn screw counterclockwise to decrease pressure. See specifications in Figure 12 for correct pressure for each model.
5. Stop heater (see page 5).
6. Remove pressure gauge. Replace pressure gauge plug in fuel pump port marked "GAUGE."

Model	Pump Pressure
350,000 Btu/Hr	100 PSI
600,000 Btu/Hr	110 PSI

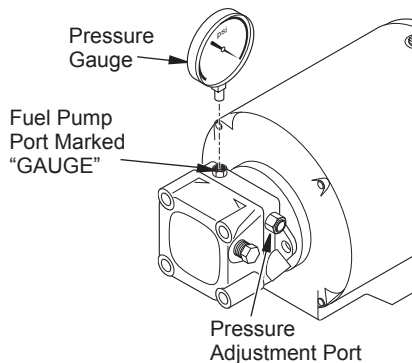

Figure 12 - Adjusting Pump Pressure

SERVICE PROCEDURES

Continued

PUMP

(Procedure if Pump is Binding)

1. Remove upper shell (see *Upper Shell Removal*, page 10).
2. Loosen hex screw on flange clamp at rear of motor with 5/16" nut-driver (see Figure 13).
3. Turn fan with hand (see Figure 14).
4. If fan turns freely, tighten screw on flange clamp.
5. If fan does not turn freely, replace pump.
6. Replace upper shell.

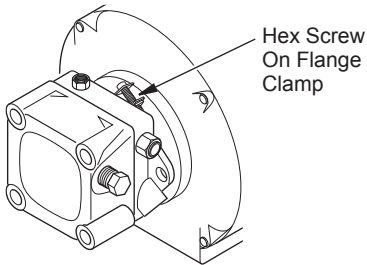

Figure 13 - Location of Screw on Flange Clamp

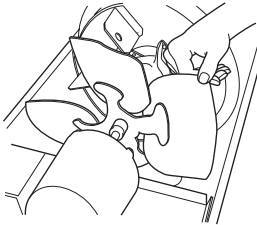

Figure 14 - Turning Fan with Hand

FUEL LINES

(Procedure for Tightening Fuel Lines)

1. Remove upper shell (see *Upper Shell Removal*, page 10).
2. Use an adjustable wrench as a backup on fittings.
3. Use 7/16" wrench and tighten fuel lines at solenoid valve, pump and fuel filter canister (if equipped) (see Figures 15 and 16).

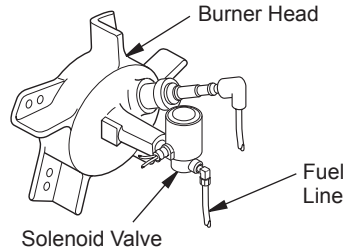

Figure 15 - Fuel Line at Solenoid Valve

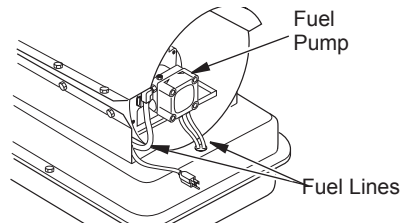

Figure 16 - Fuel Lines at Pump

SERVICE PROCEDURES

Continued

FUEL FILTERS

A. Tank Fuel Filter

1. Disconnect fuel lines from pump and fuel filter canister (if equipped) with 7/16" wrench (see Figures 17 or Figure 18 on page 13).
2. Carefully pry fuel filter loose from fuel tank with flat end of screwdriver.
3. Inspect fuel filter for water or dirt.
4. Rinse fuel filter and fuel lines with clean kerosene.
5. Replace fuel filter into fuel tank.
6. Connect fuel lines to pump and fuel filter canister (if equipped).

B. For Heaters With Fuel Filter/Canister External To Pump

1. Unscrew canister bottom from canister top with adjustable pliers.
2. Remove fuel filter and gasket from canister bottom (see Figure 18).
3. Inspect canister bottom and fuel filter for water droplets or dirt.
4. Rinse canister bottom in clean kerosene.
5. Wipe inside of canister bottom dry with clean cloth.
6. Rinse fuel filter in clean kerosene.
7. Put clean fuel filter and gasket back in canister bottom.
8. Screw canister bottom into canister top.
9. Tighten securely. Check for leaks.

C. For Heaters With Fuel Filter Internal To Pump

1. Remove pump cover to access filter
2. Rinse and wipe inside of pump cover and dry with clean cloth.
3. Rinse fuel filter in clean kerosene or blow compressed air from inside out.
4. Reassemble. Tighten securely. Check for leaks.

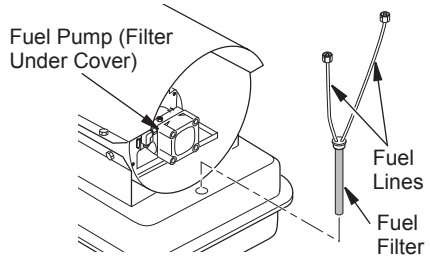

Figure 17 - Removing Tank Fuel Filter

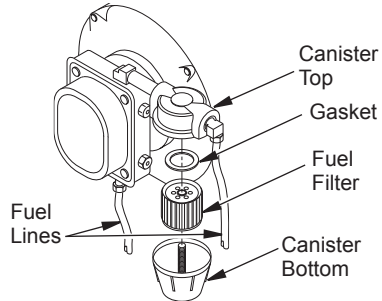

Figure 18 - Fuel Pump Filter and Canister

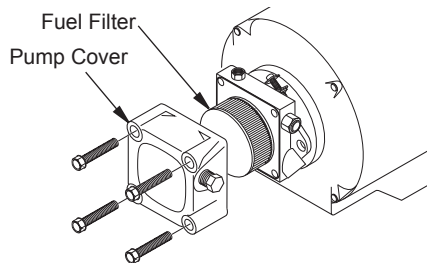
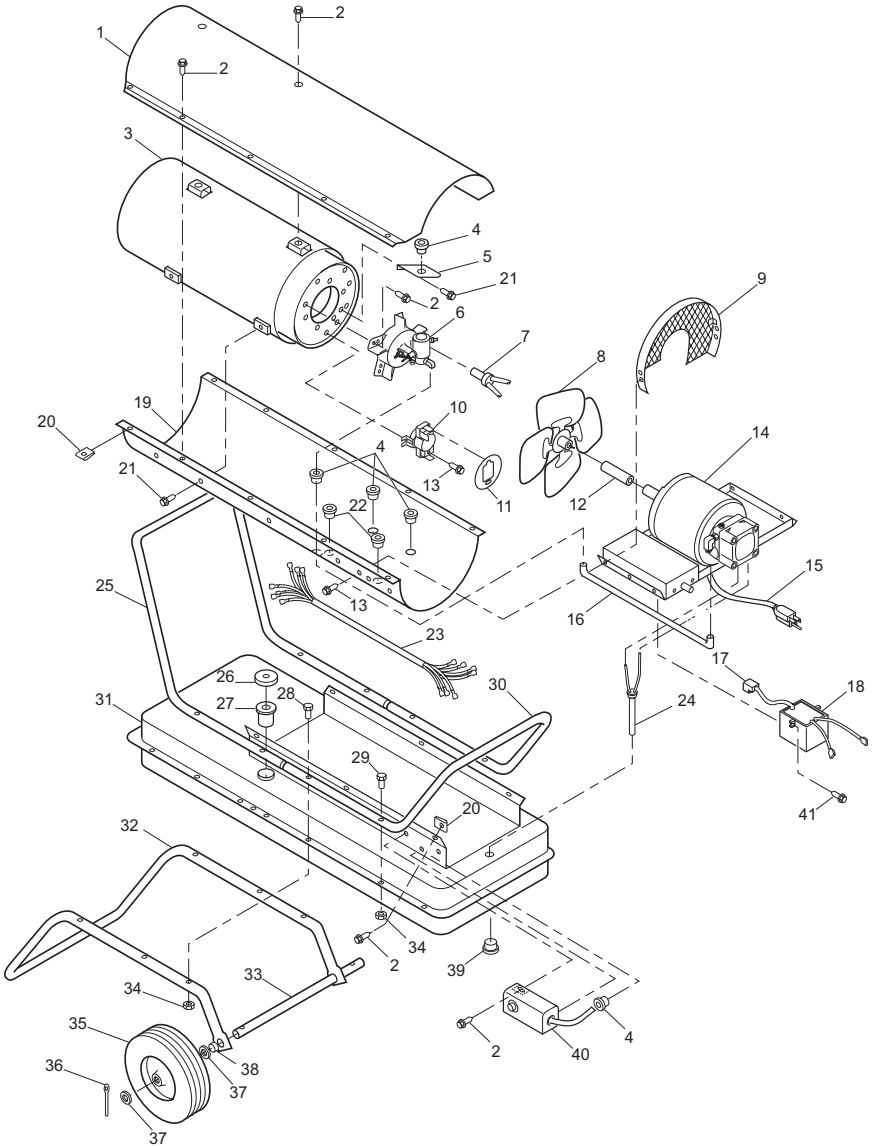

Figure 19 - Fuel Pump and Filter

ILLUSTRATED PARTS BREAKDOWN

MODELS B350D, SB350D AND R350A



PARTS LIST

This list contains replaceable parts used in your heater. When ordering parts, follow the instructions listed under *Repair Service* on the back page of this manual.

MODELS B350D, SB350D AND R350A

KEY NO.	PART NO.	DESCRIPTION	QTY.
1	108436-02	Upper shell model B350D/SB350D (Yellow)	1
	108436-01	Upper shell model R350A (White)	1
2	M11084-27	Screw, #10-16 x 1/2"	15
3	M50542-01	Combustion chamber & shield	1
4	M30865-02	Bushing	7
5	M50086	Air deflector	5
6	**	Burner head assembly	1
7	M16656-17	Photocell assembly	1
8	M50121	Fan	1
9	108446-01	Fan guard	1
10	M51336-02	Fan switch	1
11	M51160-01	Fan switch cover	1
12	M50278	Sleeve	1
13	M11084-26	Screw, #10-16 x 3/8"	13
14	**	Motor & pump assembly	1
15	099896-01	Power cord	1
16	M50295-02	Fuel line	1
17	M50050	Ignition boot	1
18	102482-04	Electronic Ignitor	1
19	108437-02	Lower shell model B350D/SB350D (Yellow)	1
	108437-01	Lower shell model R350A (White)	1
20	M11271-8	Clip nut	16
21	M11084-3	Screw, #12-14 x 1/2"	14
22	M50104-02	Bushing	2
23	099509-01	Wire harness	1
24	M50115-01	Fuel line assembly	1
25	M50062-03	Front handle	1
26	097702-01	Fuel cap	1
27	HA2210	Filler neck screen	1
28	HC4-18C	Screw, 1/4-20 x 2 1/4"	6
29	M51043-01	Screw, 1/4-20 x 1 1/2"	2
30	M50062-04	Rear handle	1
31	098513-05	Fuel tank	1
32	M50063	Wheel support frame	1
33	M18774	Axle	1
34	NTC-4C	Hex lock nut, 1/4-20	8
35	M50389	Wheel	2
36	C5-10C	Cotter pin, 5/32 x 1 1/4"	2
37	WP-10C	Flatwasher, 5/8"	4
38	M50296	Wheel spacer	2
39	M27417	Drain plug	1
40	099895-01	Thermostat	1
41	M11084-29	Screw, #10-16 x 3/4"	2

** Not available as complete assembly. See pages 18 through 20.

ILLUSTRATED PARTS BREAKDOWN

MODELS B600D, SB600D AND R600A

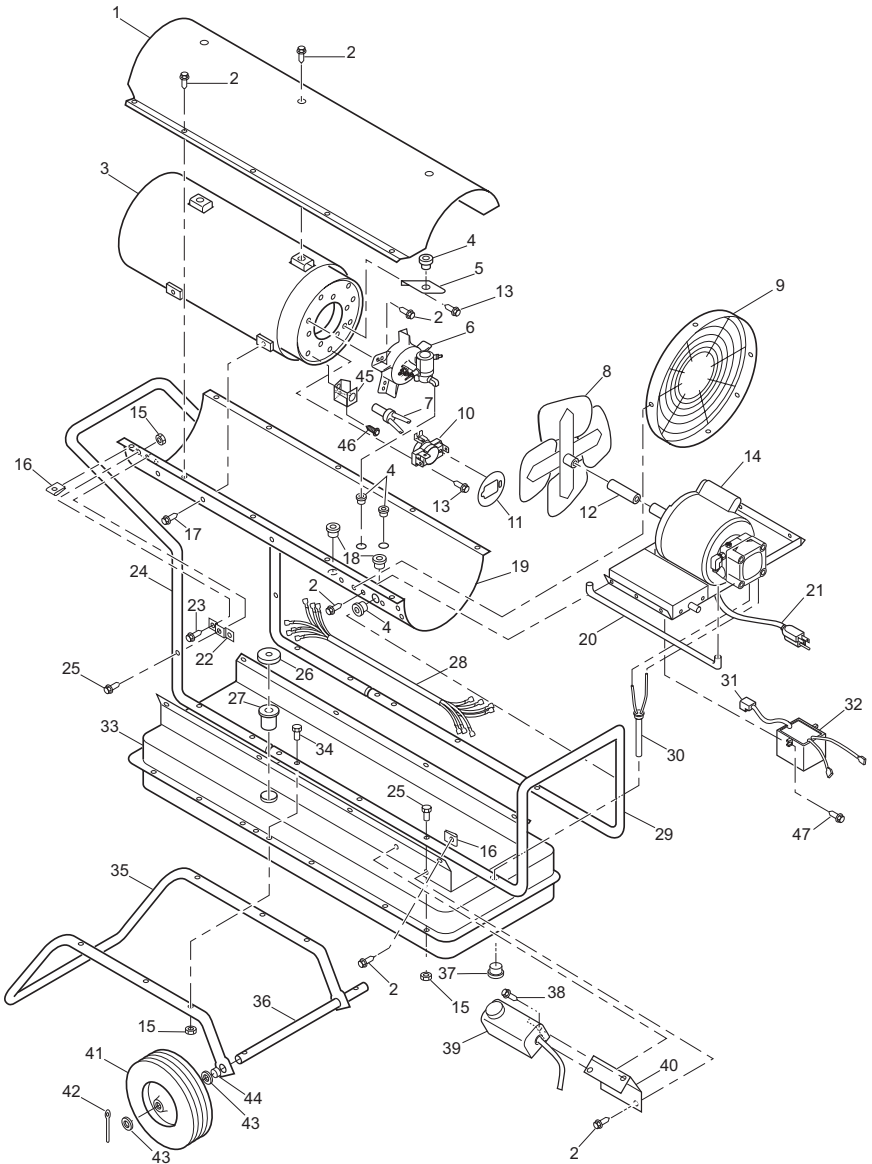

PARTS LIST

This list contains replaceable parts used in your heater. When ordering parts, follow the instructions listed under Repair Service on the back page of this manual.

MODELS B600D, SB600D AND R600A

KEY NO.	PART NO.	DESCRIPTION	QTY.
1	108396-02	Upper shell model B600D/SB600D (Yellow)	1
	108396-01	Upper shell model R600A (White)	1
2	M11084-27	Screw, #10-16 x 1/2"	28
3	M50543-01	Combustion chamber & shield	1
4	M30865-02	Bushing	5
5	M50157	Air deflector	5
6	**	Burner head assembly	1
7	104679-01	Photocell assembly	1
8	M50194	Fan	1
9	106004-01	Fan guard	1
10	M51336-02	Fan switch	1
11	M51160-01	Fan switch cover	1
12	M50278	Sleeve	1
13	M11084-26	Screw, #10-16 x 3/8"	15
14	**	Motor & pump assembly	1
15	NTC-4C	Hex nut, 1/4-20	18
16	M11271-8	Clip nut	18
17	M11084-3	Screw, #12-14 x 1/2"	4
18	M50104-02	Bushing	2
19	108397-02	Lower shell model B600D/SB600D (Yellow)	1
	108397-01	Lower shell model R600A (White)	1
20	M50295-03	Fuel line	1
21	099896-01	Power cord	1
22	M50388-02	Support bracket model	2
23	HC4-3C	Screw, 1/4-20 x 3/8"	4
24	M50224	Front handle	1
25	M51043-01	Screw, 1/4-20 x 1 1/2"	6
26	097702-01	Fuel cap	1
27	HA2210	Filler neck screen	1
28	099509-02	Wire harness	1
29	M28872-01	Rear handle	1
30	M50115-02	Fuel line assembly	1
31	M50050	Ignition boot	1
32	102482-04	Electronic Ignitor	1
33	098513-07	Fuel tank	1
34	HC4-22C	Screw, 1/4-20 x 2 3/4"	8
35	M28140-02	Wheel support frame	1
36	M18774	Axle	1
37	M27417	Drain plug	1
38	RC1-3C	Screw, #6-32 x 3/8"	2
39	099895-01	Thermostat	1
40	M25121-02	Thermostat bracket	1
41	M50389	Wheel	2
42	C5-10C	Cotter pin, 5/32 x 1 1/4"	2
43	WP-10C	Flatwasher, 5/8"	4
44	M50296	Wheel spacer	2
45	104413-01	Photocell Bracket	1
46	M10908-2	Screw, #6-32 x 3/8"	2
47	M11084-29	Screw, #10-16 x 3/4"	2
	****	Internal lockwasher No. 6	2
	NPC-1C***	Nut, 6-32	2

** Not available as complete assembly. See pages 18 through 20.

*** Not shown

**** Standard hardware item

ILLUSTRATED PARTS BREAKDOWN AND PART LIST

BURNER HEAD ASSEMBLY 350,000 AND 600,000 BTU/HR

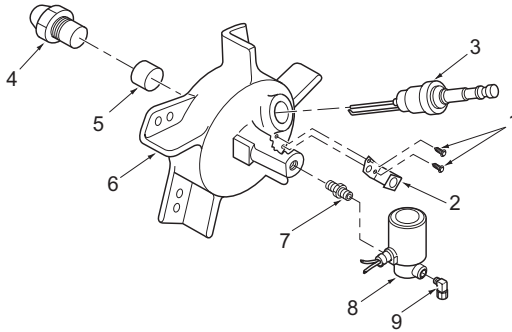

REF NO.	PART NO.	DESCRIPTION	QTY.
1	M10908-2	Screw, #6-32 x 3/8" (350,000 Btu/Hr Only)	2
2	099229-01	Photo cell Bracket (350,000 Btu/Hr Only)	1
3	HA3012	Spark Plug	1
4	M50112	Nozzle (350,000 Btu/Hr)	1
	M30765	Nozzle (600,000 Btu/Hr)	1
5	M51170-01	Plug	1
6	M50924-02	Burner Head Body	1
7	69246	Straight Nipple	1
8	M50077	Solenoid Valve	1
9	M50297	Compression Elbow	1

ILLUSTRATED PARTS BREAKDOWN AND PART LIST

MOTOR AND PUMP ASSEMBLY 350,000 AND 600,000 BTU/HR HEATERS WITH FUEL FILTER INTERNAL TO PUMP

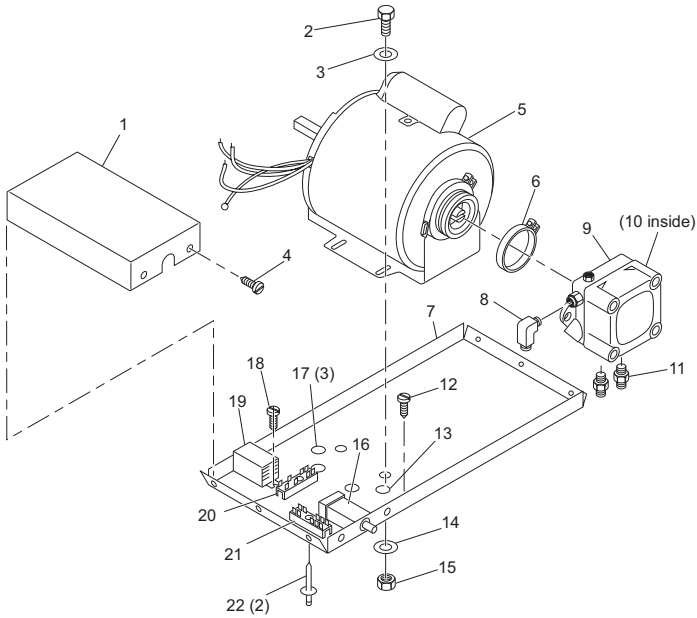

REF. NO.	PART NO.	DESCRIPTION	QTY.
1	097492-03	Wiring cover	1
2	HF5-5C	Screw, 5/16-24 x 5/16"	4
3	WLE-5	External lockwasher, 5/16"	4
4	M11084-26	Screw, #10-16 x 3/8"	3
5	099562-01	Motor (350,000 Btu/Hr)	1
	099562-02	Motor (600,000 Btu/Hr)	1
6	M50116	Flange clamp (holds pump to motor)	1
7	099518-05	Motor support (350,000 Btu/Hr)	1
	101552-01	Motor support (600,000 Btu/Hr)	1
8	M50297	Compression elbow	1
9	098560-02	Fuel pump	1
10	110381-01	Filter element and gasket (inside fuel pump)	1
11	M50113-02	Straight fitting	2
12	M10908-14	Screw, #8-32 x 3/8"	1
13	101504-01	Strain relief bushing	1
14	**	Lockwasher, 5/16"	4
15	NPF-5C	Hex nut, 5/16-24"	4
16	HA3003	Flame-out control	1
17	101547-01	Snap bushing	3
18	M10908-2	Screw, #6-32 x 3/8"	2
19	097491-01	Power relay	1
20	099125-04	Terminal board	1
21	099125-05	Terminal board	1
22	099157-01	Rivet	2

** Standard hardware item

PART LIST

MOTOR AND PUMP ASSEMBLY 350,000 AND 600,000 BTU/HR

For Heaters With Fuel Filter/Canister External To Pump

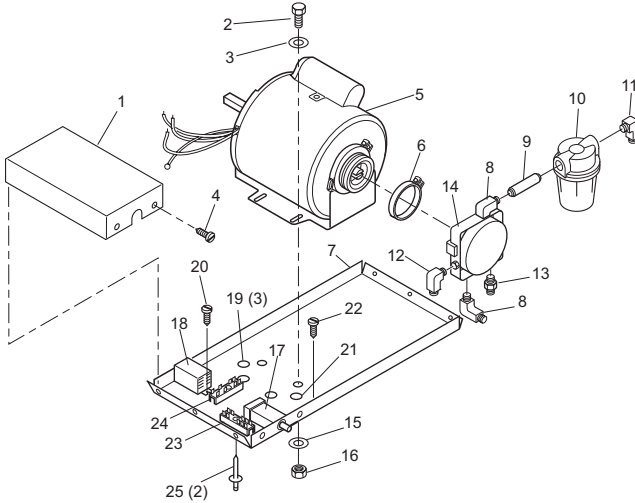

REF. NO.	PART NO.	DESCRIPTION	QTY.
1	097492-03	Wiring cover	1
2	HF5-5C	Screw, 5/16-24 x 5/16"	4
3	WLE-5	External lockwasher, 5/16"	4
4	M11084-26	Screw, #10-16 x 3/8"	3
5	099562-01	Motor (350,000 Btu/Hr)	1
	099562-02	Motor (600,000 Btu/Hr)	1
6	M50116	Flange clamp (holds pump to motor)	1
7	099518-05	Motor support (350,000 Btu/Hr)	1
	101552-01	Motor support (600,000 Btu/Hr)	1
8	57413	Street elbow	2
9	M17499-2	Pipe nipple	1
10	098102-01	Fuel filter assembly	1
	098103-01	Filter element (inside fuel filter assembly, includes rubber gaskets)	1
11	M50114-02	90° Male elbow	1
12	M50297	Compression elbow	1
13	M50113-02	Straight fitting	1
14	098560-02	Fuel pump	1
15	**	Lockwasher, 5/16"	4
16	NPF-5C	Hex nut, 5/16-24"	4
17	HA3003	Flame-out control	1
18	097491-01	Power relay	1
19	101547-01	Snap bushing	3
20	M10908-2	Screw, #6-32 x 3/8"	2
21	101504-01	Strain relief bushing	1
22	M10908-14	Screw, #8-32 x 3/8"	1
23	099125-05	Terminal board	1
24	099125-04	Terminal board	1
25	099157-01	Rivet	2

** Standard hardware item

SPECIFICATIONS

	350,000 Btu/Hr	600,000 Btu/Hr
Output Rating (Btu/Hr)	350,000	600,000
Fuel	Use only kerosene, #1#2 diesel/fuel oil, JET A or JP-8 fuels	
Fuel Tank Capacity (U.S. Gallons)	30	36
Fuel Consumption (Gallons Per Hr)	2.5	4
Electric Requirements	120V/60 Hz	120V/60 Hz
Amperage (Normal Run)	7.1	11
Motor RPM	1725	1725
Fuel Pump Pressure (PSI)	100	110
Spark Plug Gap	.075"	.075"
Weight (approx. lbs.) Dry	180	285
With Full Fuel Tank	390	550

WIRING DIAGRAM

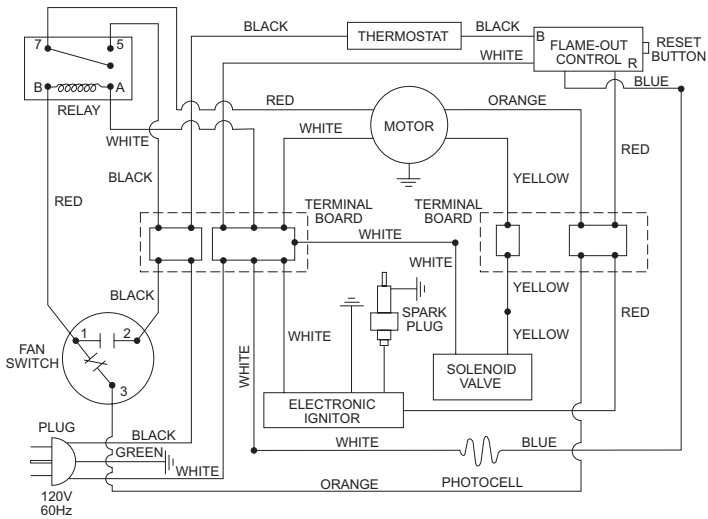

MAINTENANCE KITS

Kit

Flame-Out Control
Spark Plug

Part Number

HA3003
HA3012

TECHNICAL SERVICE

You may have further questions about installation, operation or troubleshooting. If so, contact DESA Heating Products' Technical Service Department at 1-866-672-6040. When calling please have your model and serial numbers of your heater ready.

You can also visit DESA Heating Products' Technical Services web site at www.desatech.com.

ACCESSORY

Purchase this heater accessory from your nearest dealer or service center. If they cannot supply this accessory, either contact your nearest Parts Central or DESA Heating Products at 1-866-672-6040 for information. Parts Centrals are listed in the Authorized Service Center booklet supplied with heater.

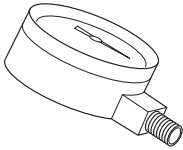

FUEL PRESSURE GAUGE - 110380-01

Special tool to check fuel pump pressure.

REPLACEMENT PARTS

Note: Use only original replacement parts. This will protect your warranty coverage for parts replaced under warranty.

PARTS UNDER WARRANTY

Contact authorized dealers of this product. If they can't supply original replacement part(s), call DESA Heating Products' Technical Service Dept. at 1-866-672-6040.

When calling DESA Heating Products, have ready:

- your name
- your address
- model and serial numbers of your heater
- how heater was malfunctioning
- purchase date

Usually, we will ask you to return the part to the factory.

PARTS NOT UNDER WARRANTY

Contact authorized dealers of this product. If they can't supply original replacement part(s), call DESA Heating Products at 1-866-672-6040 for referral information. Parts dealers are listed in the Authorized Service Center booklet supplied with heater.

When calling DESA Heating Products, have ready:

- model and serial numbers of your heater
- the replacement part number

NOTES

WARRANTY AND REPAIR SERVICES

LIMITED WARRANTY

DESA Heating Products warrants this product and any parts thereof, to be free from defects in materials and workmanship for one (1) year from the date of first purchase when operated and maintained in accordance with instructions. This warranty is extended only to the original retail purchaser, when proof of purchase is provided.

This warranty covers only the cost of parts and labor required to restore the product to proper operating condition. Transportation and incidental costs associated with warranty repairs are not reimbursable under this warranty.

Warranty service is available only through authorized dealers and service centers.

This warranty does not cover defects resulting from misuse, abuse, negligence, accidents, lack of proper maintenance, normal wear, alteration, modification, tampering, contaminated fuels, repair using improper parts or repair by anyone other than an authorized dealer or service center. Routine maintenance is the responsibility of the owner.

THIS EXPRESS WARRANTY IS GIVEN IN LIEU OF ANY OTHER WARRANTY EITHER EXPRESSED OR IMPLIED, INCLUDING WARRANTIES OF MERCHANTABILITY AND FITNESS FOR A PARTICULAR PURPOSE.

DESA Heating Products assumes no responsibility for indirect, incidental or consequential damages. Some states do not allow the exclusion or limitation of incidental or consequential damages or limitations or exclusions may not apply to you. This Limited Warranty gives you specific legal rights and you may also have other rights which vary from state to state.

WARRANTY SERVICE

Should your heater require service, return it to your nearest authorized service center. Proof of purchase must be presented with the heater. The heater will be inspected. A defect may be caused by faulty materials or workmanship. If so, DESA Heating Products will repair or replace the heater without charge.

REPAIR SERVICE

Return the heater to your nearest authorized service center. Each Service Center is independently owned and operated. Repairs not covered by the warranty will be billed at standard prices. We reserve the right to amend these specifications at any time without notice.

Illustrated parts lists can be obtained free of charge. Send a self addressed stamped envelope to the address listed below. List the heater model number and the date located in the lower right corner of this page. A service manual may be purchased from the address listed below. Send a check for \$5.00 payable to DESA Heating Products.

When writing for information regarding your heater, be sure to include the model number and serial number as shown on the model plate.

For more information about this warranty, write:

DESA[™]
HEATING PRODUCTS

2701 Industrial Drive
P.O. Box 90004
Bowling Green, KY 42102-9004
www.desatech.com



110098 01
NOT A UPC

110098-01
Rev. F
11/04