



**Continental Disc<sup>®</sup>  
Corporation**

---

3160 WEST HEARTLAND DRIVE LIBERTY, MISSOURI 64068-3385  
PHONE: (816) 792-1500 FAX: (816) 792-2277 / 5447

## BDI-FLX<sup>™</sup> 2W-NIS BURST DISC SENSOR SYSTEM OPERATOR'S MANUAL

### **IMPORTANT**

USER SHOULD READ CAREFULLY AND UNDERSTAND  
THIS MANUAL BEFORE INSTALLING, OPERATING OR  
TESTING THIS UNIT

TABLE OF CONTENTS

|       |   |   |
|-------|---|---|
| I.    | PRODUCT DESCRIPTION .....                 | 3 |
| II.   | SPECIFICATIONS .....                      | 4 |
| III.  | HANDLING AND UNPACKING .....              | 4 |
| IV.   | STORAGE .....                             | 5 |
| V.    | INSTALLATION .....                        | 5 |
| VI.   | MAINTENANCE .....                         | 8 |
| VII.  | LIMITED WARRANTY .....                    | 8 |
| VIII. | DISCLAIMER OF WARRANTIES .....            | 8 |
| IX.   | DISCLAIMER OF CONSEQUENTIAL DAMAGES ..... | 9 |
| X.    | WARRANTY EXCLUSIONS .....                 | 9 |

## I. PRODUCT DESCRIPTION

**WARNING:** For full liquid applications: The BDI-FLX Sensor requires dynamic movement to signal. Slow reversal of the rupture disc, such as with liquid thermal expansion, will not cause the BDI-FLX Sensor to indicate. A small crack in a rupture disc score will not cause the BDI-FLX Sensor to indicate. Note that the BDI-FLX Sensor is designed to indicate within a few milliseconds, so full reversal and full opening of the rupture disc must occur within a few milliseconds. If full liquid flow at set pressure or a gas head will not be present during rupture of disc, contact CDC for evaluation.

The BDI-FLX™ Burst Disc Sensor Systems are designed to continuously monitor the status of rupture discs and output a switch signal to a system when such rupture discs have relieved an over-pressure condition. The system is comprised of two components: the BDI-FLX sensor and the BDI-FLX interface cable. The interface cable processes the sensor's signal and outputs a switch type signal.

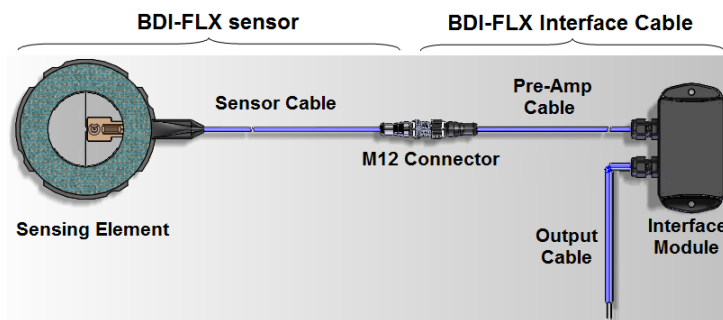

The BDI-FLX Burst Disc Sensor Systems contain numerous advances in rupture disc burst monitoring and alarm switching technology. Designed to meet the needs of a variety of applications and diverse industries, the BDI-FLX product family includes three models:

- BDI-FLX 2W-IS for use in hazardous environments and intrinsically safe applications
- BDI-FLX 2W-NIS for direct PLC or DCS discrete input
- BDI-FLX 4W-NIS for use as dry contact switch that can be used with a wide variety of power options and control/alarm inputs

This user manual provides detail specifications, electrical system requirements, wiring and operating instructions for model 2W-NIS.

The BDI-FLX 2W-NIS model is a 2-wire instrument that provides a digital switching signal over a single pair of wires. This design is suitable for applications when the user wants the rupture disc signal to be sent directly to the digital input channel of a Programmable Logic Controller (PLC) or a Distributed Control System (DCS). It is powered from the PLC/DCS discrete input or other suitable in-series load to which it is connected and no separate power wiring is required.

The interface cable contains a built-in microprocessor that processes the sensor signal and produces a logic output, offering plant operators a reliable rupture disc status signal. The unit outputs a continuous current signal (12 mA typical) as disc in normal operation and requires maximum 0.85 mA leakage current flowing through the load which is in-series connected to the module when switching OFF.

The interface cable incorporates a “failsafe” design: should there be a disc burst or an interruption of the sensor signal or power line, the output of the interface module is always switched automatically to the “OFF” condition.

## II. SPECIFICATIONS



### Electrical Specifications

|                                    |  |
|------------------------------------|--|
| Input Power:                       | 7~30 VDC (including voltage fluctuation)   |
| Operating Temperature:             | BDI-FLX Interface Cable -40°C to 70°C (-40°F to 158°F)<br>BDI-FLX Sensor -40°C to 204°C (-40°F to 400°F) |
| Output Configuration:              | ON: output 12 mA typical (min: 10.5 mA; max: 12.5 mA)<br>OFF: max: 850 µA; min: 75 µA                    |
| Power-up Time Delay:               | 62 ms  |
| Polarity Protection:               | Protected (up to 60 V)   |
| Transient Over-voltage Protection: | Protected  |
| Output Cable:                      | 18 AWG, shielded twisted pair (STP) PVC tray cable (TC), CMG under UL-NEC                                |

### Mechanical Specifications

|                               |                                       |
|-------------------------------|---------------------------------------|
| Housing Material:             | ABS                                   |
| Housing Inflammability Class: | UL 94 V-0                             |
| Housing Dimensions:           | 3.1 x 2.1 x 1.1 in. / 79 x 54 x 28 mm |
| Mounting:                     | Panel Mount                           |
| Cable Gland Material:         | Nylon                                 |
| Cable OD:                     | 5.8 mm                                |
| Degree of Protection:         | IP67                                  |

### Regulatory Information:

|   |   |
|---|---|
|  | This product is designed and manufactured to comply with all applicable United States and Canadian safety requirements and is UL & cUL recognized.<br>UL File no. E350819   |
|  | This product has been tested to the requirements of CAN/CSA-C22.2 No. 61010-1, second edition, including Amendment 1, or a later version of the same standard incorporating the same level of testing requirements. |

## III. HANDLING AND UNPACKING

The personnel responsible for the assembly, operation, inspection and maintenance of the BDI-FLX Burst Disc Sensor System must be appropriately qualified.

The BDI-FLX Burst Disc Sensor System is a precision device. Always follow these guidelines when handling and unpacking the product to prevent damage:

- A. Use care when unpacking/handling the product.
- B. Inspect the package for damage or missing items upon delivery.
- C. Mark any damage or missing items and report it to Customer Service at Continental Disc Corporation.

**WARNING: POTENTIAL ELECTROSTATIC CHARGING HAZARD!**

**Precautions should be taken to reduce the risk of electrostatic charge. Prevent unintentional contact or cleaning with a dry cloth. Clean ONLY with a damp cloth. Do NOT use any solvent.**

**CAUTION:** Always observe the applicable local standards, regulations and safety requirements. Failure to comply with required safety precautions may result in serious injury or damage to people/property/product and loss of all claims for damages.

## IV. STORAGE

The BDI-FLX interface cable is to remain packed in the box in which it is shipped until ready for installation. This unit should be stored in a cool dry atmosphere with ambient temperatures within -40°C to +50°C (-40°F to +122°F).

## V. INSTALLATION

**WARNING:** These installation and servicing instructions are for use by qualified personnel only. To avoid injury and electrical shock, do not perform any servicing other than that contained in this manual. The installation and wiring of this unit should be performed in accordance with the latest edition of the governing Electrical Code.

**WARNING:** Disconnect power to the unit before wiring.

**NOTE:** This section describes the procedures and requirements for connecting the BDI-FLX 2W-NIS interface cable to the user's system. For installation of the BDI-FLX sensor please refer to "Preparation and Installation of the BDI-FLX Sensor and Connection to the BDI-FLX Interface Cable Assembly" document provided with the BDI-FLX sensor.

1. The BDI-FLX sensor system is not equivalent to a traditional mechanical switch. The user must read carefully the installation procedure for the selected model and verify that their system meets the required conditions for the specific unit.
2. The BDI-FLX 2W-NIS System drops a certain amount of voltage in the ON state. This voltage drop determines how many volts the load (e.g., the control system digital input channel) can obtain from the supply voltage. If the supply voltage minus the voltage drop is not sufficient for load normal operation, the load will not turn ON. Check the receiving system manufacturer's specifications for the input ON voltage threshold. A resistor may be required to ensure the appropriate voltage drop across the load is obtained for an externally powered discrete input.
3. The BDI-FLX 2W-NIS System leaks a small amount of current through the loop when it outputs a switching "OFF" signal. This current value is minimum 0.075 mA at normal environmental condition and maximum 0.85 mA if under specified operating conditions. The current flows through the load and produces a small voltage across the load. If this voltage is greater than the value that will allow it to turn "OFF", the load will remain in the ON state although the sensor unit has switched OFF. Check the manufacturer specifications for the input OFF voltage threshold.
4. The BDI-FLX 2W-NIS System output is designed as Normally Closed (ON state) when powered. Each time the unit is powered up, the output stays OFF for about 62 ms (power-up time delay) then switches ON. This warm-up period allows the power line to stabilize. User should examine their receiving system power-up set time for logic adaptation.
5. The BDI-FLX burst disc sensor system is designed for continuous monitoring of a rupture disc. **When powering up on initial installation or upon restoring power from a lost power condition, the unit will reset itself automatically.** When the BDI-FLX system trips an OFF signal as a result of a disc burst, the user should replace the rupture disc and BDI-FLX sensor. The user can reuse the interface cable. **Re-powering the system without replacing the BDI-FLX sensor could result in a false normal (ON) signal.**

**WARNING:** This unit is not designed/rated for hazardous environments.

**WARNING:** Do not connect the BDI-FLX 2W-NIS output wires directly to a power supply without a suitable load or current limiting device in series with the unit.

**CAUTION:** Lead polarity must be observed when connecting the two wires to the PLC or DCS input channel.

**Operating Requirements:**

In normal operation, the BDI-FLX 2W-NIS outputs an ON signal to the load (PLC or DCS digital input channel) through sourcing or sinking a current (12 mA typical) and has a voltage drop across the 2W-NIS that varies depending on voltage input. In the event of a rupture disc burst or sensor wiring failure, the 2W-NIS outputs an OFF signal to the PLC or DCS input by drawing a small amount of current (leakage current) of maximum 0.85 mA with a voltage drop across the 2W-NIS. For proper application of voltage to PLC, using the output current rating, select load resistor to

develop the correct voltage levels to the PLC inputs. The following conditions must all be met for proper function of the device:

1. The ON voltage of the load ( $V_{load}$ , in Volts) and the power supply ( $V_{pw}$ , in Volts) in series with the loop must satisfy  
 **$V_{load} \leq V_{pw} - 5.5V$ , for example**

NOTE: If the power supply voltage is in a range, e.g., 24 VDC ( $\pm 20\%$ ),  $V_{pw}$  uses the minimum value of the power voltage, i.e.,  $V_{pw} = 19.2 V$ .

NOTE: If the load impedance ( $R_{load}$ ) such as its internal resistance is given a constant and it reflects the total load voltage, the  $V_{load}$  can be calculated approximately as  $V_{load} \text{ (volts)} = R_{load} \text{ (k}\Omega) \times 12 \text{ (mA)}$ .

2. ON state input signal current for the load ( $I_{ON}$ ) must satisfy  
 **$I_{ON} \leq 10.5 \text{ mA}$ .**
3. OFF state input signal current for the load ( $I_{OFF}$ ) must satisfy  
 **$I_{OFF} \geq 0.85 \text{ mA}$ .**

**CAUTION:** For exact values always refer to specs of user PLC or DCS input module and its wiring diagram supplied by the manufacturer. Also check whether the input module uses a built-in DC power supply.

**Wiring Diagram:**

## INTERNALLY POWERED DISCRETE INPUT

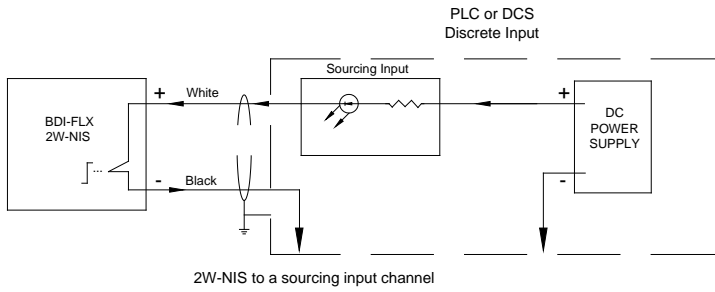

## EXTERNALLY POWERED DISCRETE INPUT

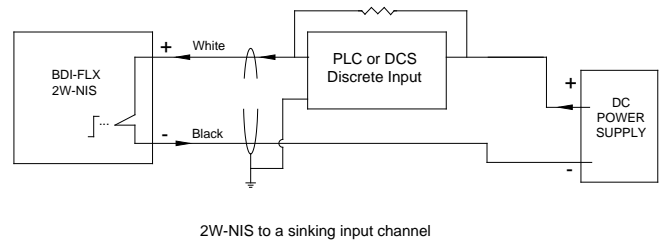
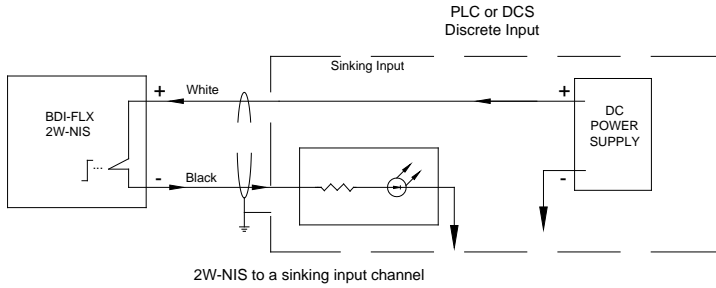
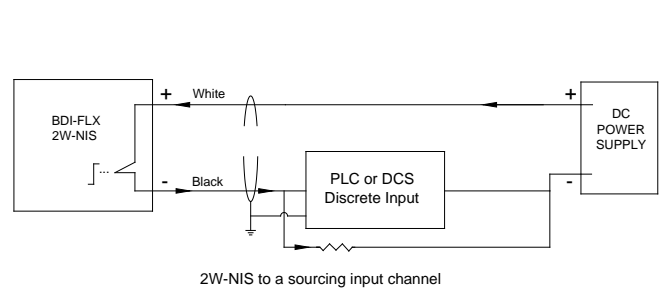

**Note:** The shield (drain wire) of the 2W-NIS output cable should be connected to ground at the PLC or DCS site and ground only at one point throughout the shield.

Shielded twisted pair cable should be used as extension cable when needed. The shield of the shielded twisted pair cables should be connected at the terminal block and insulated from the metal case, other conductors or ground.

### **Installation:**

#### **1. Mount the BDI-FLX Interface Cable Enclosure**

Bolt the BDI-FLX interface cable enclosure to a panel rack using mounting holes. Consider the distance and location for convenient sensor connection.

#### **2. Connect BDI-FLX Sensor to the BDI-FLX Interface Cable model 2W-NIS**

Connect the BDI-FLX sensor to the BDI-FLX interface cable through the M12 connector. After insertion, fasten the M12 screw ring to lock the connection.

#### **3. Connect Output Cable**

Terminate the output cable wires according to the wiring diagram. The 2W-NIS two wires are typically routed into the receiving system (PLC or DCS) discrete input channel. Terminate all other correlated wires and ground properly before operation.

#### **4. Final Check**

Check all wiring to ensure proper connections with no unwanted possible shorts, grounds, or open circuits.

#### **5. Energize Power to Unit**

With the disc, sensor system and output load installed and properly connected the unit can be powered and ready for operation.

## **VI. MAINTENANCE**

The BDI-FLX interface cables have been designed to operate with little maintenance required. Periodic checks should be made to ensure the units are clean and free from contaminating, humid or hot atmospheres, and are in good physical and electrical condition.

Should the system fail to function properly, the user should check for the following items where applicable:

- A. All specified conditions of the connected system listed in [Section V](#) are met.
- B. The unit is connected to the control input channel in the correct polarity.
- C. There is no ground loop through the cable signal transmission.
- D. The BDI-FLX sensor has been properly connected to the interface cable prior to powering the unit.
- E. The power is on.
- F. All wiring is connected properly per this instruction manual.
- G. The connected terminal blocks or input channels are working properly.
- H. The user receiving system (PLC/DCS, etc.) is functioning properly.
- I. There is no short or open circuit in the disc sensor, interface cable or connectors.
- J. The disc and sensor are in good condition.

**Note:** If the sensor has tripped an OFF signal due to disc burst or signal interruption, the system needs to be reset following instructions listed in [Section V](#).

The BDI-FLX interface modules are designed with industrial category components and every effort has been made to make the unit as easily serviceable as possible. Should there be a problem before or during operation please contact Continental Disc Corporation Customer Service for assistance. Do not repair or modify the product without consultation of Continental Disc Corporation.

Disassembly of the unit and/or replacement of components may lead to improper function of the system and safety hazards.

## **VII. LIMITED WARRANTY**

Products manufactured by Continental Disc Corporation have a warranty against defective workmanship and material for a period of one year after date of invoice. In no event shall Continental Disc Corporation's liability for damages with respect to any of the products furnished under this Agreement exceed the charges previously paid by the customer to Continental Disc Corporation for such products. Buyer's sole remedy for breach of this Agreement is repair or replacement of defective parts furnished by Continental Disc Corporation, which have been returned to Continental Disc Corporation's factory at purchaser's expense. It is expressly agreed between purchaser and Continental Disc Corporation that the remedy of repair and replacement is the exclusive and sole remedy of the purchaser.

## **VIII. DISCLAIMER OF WARRANTIES**

Except as specifically provided in this Agreement, there are no warranties, expressed or implied, including, but not limited to any implied warranties of merchantability or fitness for a particular purpose.



## **IX. DISCLAIMER OF CONSEQUENTIAL DAMAGES**

In no event shall Continental Disc Corporation be liable for consequential damages, including but not limited to damages for loss of use, damages for lost profits, and damages for resulting harm to property other than the Continental Disc Corporation assemblies and their component parts.

Customer acknowledges and understands that the provisions of these additional terms and conditions, including this paragraph concerning disclaimer of consequential damages and limitation or remedy, apply fully to the purchase of the products.

## **X. WARRANTY EXCLUSIONS**

This warranty does not apply in the event of misuse or abuse of the product or as a result of unauthorized alterations or repairs.