

# DYNAVENT<sup>®</sup>

## WINDOW WALL FURNACE

### DIRECT-VENT NATURAL GAS HEATER

#### OWNER'S OPERATION AND INSTALLATION MANUAL

**DNV25NB**  
**DNV40NB**

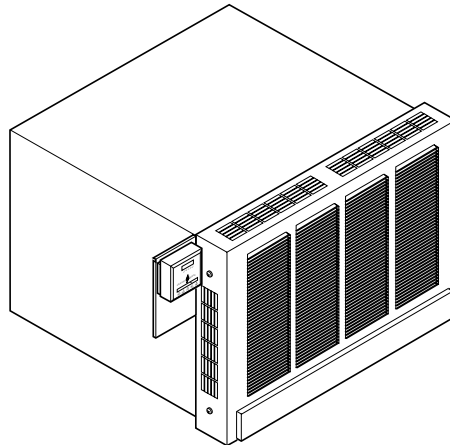

25,000 and 40,000 BTU/Hr "B" Model Furnaces

**WARNING:** If the information in these instructions is not followed exactly, a fire or explosion may result causing property damage, personal injury, or loss of life.

#### FOR YOUR SAFETY

Do not store or use gasoline or other flammable vapors and liquids in the vicinity of this or any other appliance.

#### FOR YOUR SAFETY

##### WHAT TO DO IF YOU SMELL GAS

- Do not try to light any appliance.
- Do not touch any electrical switch.
- Do not use any phone in your building.
- Immediately call your gas supplier from a neighbor's phone. Follow the gas supplier's instructions.
- If you cannot reach your gas supplier, call the fire department.

**WARNING:** Improper installation, adjustment, alteration, service, or maintenance can cause injury or property damage. Refer to this manual for correct installation and operational procedures. For assistance or additional information consult a qualified installer, service agency, or the gas supplier.

— Installation and service must be performed by a qualified installer, service agency, or the gas supplier.

This appliance may be installed in an aftermarket\*, permanently located, manufactured (mobile) home, where not prohibited by local codes.

This appliance is only for use with the type of gas indicated on the rating plate. This appliance is not convertible for use with other gases.

\* Aftermarket: Completion of sale, not for purpose of resale, from the manufacturer

**Save this manual for future reference.**

# DYNAVENT®

## DIRECT-VENT NATURAL GAS HEATER

### SAFETY INFORMATION

#### WARNINGS

**IMPORTANT:** Read this owner's manual carefully and completely before trying to assemble, operate, or service this furnace. Improper use of this furnace can cause serious injury or death from burns, fire, explosion, electrical shock, and carbon monoxide poisoning.

** DANGER:** Carbon monoxide poisoning may lead to death!

**Carbon Monoxide Poisoning:** Early signs of carbon monoxide poisoning resemble the flu, with headaches, dizziness, and/or nausea. If you have these signs, the furnace may not be working properly. **Get fresh air at once!** Have furnace serviced. Some people are more affected by carbon monoxide than others. These include pregnant women, people with heart or lung disease or anemia, those under the influence of alcohol, and those at high altitudes.

**Natural Gas:** Natural gas is odorless. An odor-making agent is added to natural gas. The odor helps you detect a natural gas leak. However, the odor added to natural gas can fade. Natural gas may be present even though no odor exists.

Make certain you read and understand all warnings. Keep this manual for reference. It is your guide to safe and proper operation of this furnace.

** WARNING:** Any change to this heater or its controls can be dangerous.

**Due to high temperatures, the appliance should be located out of traffic and away from furniture and draperies.**

**Carefully supervise young children when they are in the same room with furnace.**

**Do not place clothing or other flammable material on or near the appliance. Never place any objects on the furnace.**

**Surface of furnace becomes very hot when running furnace. Keep children and adults away from hot surface to avoid burns or clothing ignition. Furnace will remain hot for a time after shut-down. Allow surface to cool before touching.**

**Turn off furnace and unplug and let cool before servicing. Unless you need gas supply for testing, shut off equipment shutoff valve before servicing. Only a qualified service person should service and repair furnace and venting system.**

**Replace any safety screen or guard removed for servicing before operating furnace.**

**You must keep control compartments, burners, and circulating air passages clean. More frequent cleaning may be needed due to excessive lint and dust from carpeting, bedding material, etc. Turn off the gas valve and unplug before cleaning furnace.**

1. A qualified service person must install furnace.
2. This appliance is only for use with the type of gas indicated on the rating plate. This appliance is not convertible for use with other gases.
3. Use only natural gas. Do not convert furnace to use different fuel type.
4. If you smell gas
  - Shut off gas supply.
  - Do not try to light any appliance.
  - Do not touch any electrical switch; do not use any phone in your building.
  - Immediately call your gas supplier from a neighbor's phone. Follow the gas supplier's instructions.
  - If you cannot reach your gas supplier, call the fire department.
5. Do not block the flow of combustion air (outside air) or heated air (room air) to the furnace.
6. This furnace must have fresh air for proper operation. If not, poor fuel combustion and improper venting of flue

gases will result. Carbon monoxide poisoning from backed-up flue gases could occur. The State of California lists carbon monoxide as a reproductive toxin under Proposition 65.

7. Never install the furnace
  - in a recreational vehicle
  - in an alcove
  - on an inside wall
  - as a fireplace insert
  - in high traffic areas
  - in windy or drafty areas
  - behind a door or where an open door would block normal air flow
8. Provide the following minimum furnace clearances from furnace front cover to combustibles (as viewed from the front of furnace):  
Below Front Cover: 6 inches  
Adjoining Wall: 12 inches  
Above Front Cover: 12 inches  
Front: 8 feet
9. Do not obstruct the flow of combustion and ventilation air in any way. Provide adequate clearances around air openings into the combustion chamber along with adequate accessibility clearance for servicing and proper operation.
10. Provide the following minimum furnace clearances from furnace cabinet (portion of cabinet extending into outside air, as viewed from the rear of furnace):  
Cabinet Back: 36 inches  
Cabinet Sides: 6 inches  
Cabinet Bottom: Must be high enough off the ground to prevent snow, water, leaves, or any other objects from blocking cabinet vents.
11. Always follow lighting instructions. Never attempt to light burner with a match or butane torch.
12. Do not run furnace
  - where flammable liquids or vapors are used or stored
  - under dusty conditions
13. Do not use furnace as a cooking device.
14. Do not alter furnace or its controls. Any change may create a safety hazard.
15. Do not use furnace if any part has been under water. Immediately call a qualified service person to inspect the furnace and to replace any part of the control system and any gas control which has been under water.

# OWNER'S MANUAL

## LOCAL CODES

Install and use furnace with care. Follow all local codes. In the absence of local codes, use the latest edition of the following:

- *National Fuel Gas Code ANS Z223.1*, also known as NFPA 54 \* (USA)
- *National Electric Code ANS/NFPA 70\**
- *CAN/CGA-B149[.1 or .2] Installation Codes\*\** (Canada).

\*Available from:

American National Standards Institute, Inc.  
1430 Broadway  
New York, NY 10018

National Fire Protection Association, Inc.  
Batterymarch Park  
Quincy, MA 02269

\*\*Available from:

Standards Council of Canada  
350 Sparks Street  
Ottawa, Ontario K1R 7S8

This furnace must be grounded when installed. Follow all local codes. In the absence of local codes, refer to the *National Electrical Code ANS/NFPA No. 70* (U.S.A.) or *CSA C22.1 Canadian Electrical Code, Part I* (Canada).

The installation must conform with local codes, in the absence of local codes, with the *National Fuel Gas Code, ANS Z223.1/Canadian Installation Code, CAN/CGA B149*.

When installing furnace in a manufactured (mobile) home, follow the *Manufactured Home Construction and Safety Standard, Title 24CFR, Part 3280* (formerly the *Federal Standard for Mobile Home Construction and Safety, Title 24, part 280; 1975*). When such a standard is not applicable, follow the *Standard for Manufactured Home Installations, 1982* (*Manufactured Home Sites, Communities, and Set-Ups*), *ANS A225.1/NFPA 501A*.

In Canada, install furnace in accordance with *Standard CSA Z240.4 - Gas Equipped Recreational Vehicles and Mobile Housing* and any applicable local codes and regulations.

Appliance input ratings are based on sea level operation and need not be changed for operation up to 2,000 feet elevation. For operation at elevations above 2,000 feet, manufactured to specified deration conditions for Canada and the United States.

## UNPACKING

1. Remove furnace from carton.
2. Remove all protective packaging applied to furnace for shipment.
3. Remove the following items from carton:
  - Hardware package containing four large screws, two small screws, and thermostat mounting plate
  - Hardware package (thermostat and two screws)
  - Equipment shutoff valve
 If any of these items are missing, promptly inform dealer where you bought furnace.
4. Check furnace for any shipping damage. If furnace is damaged, promptly inform dealer where you bought furnace.

## SPECIFICATIONS

	DNV25NB	DNV40NB
*Rated Heating Input (BTU/Hr)	25,000	40,000
Thermal Output Capacity (average loss calculation)	18,750 Btu/Hr	30,000 Btu/Hr
Type Gas	Natural Only	Natural Only
Ignition	Hot Surface Ignitor	Hot Surface Ignitor
Operating Amps	1.5	2
Volts/Cycles	120/60	120/60
Main Burner	1	2
Pressure Regulator Setting	3.5" W.C.	3.5" W.C.
Inlet Connection	3/8 NPT	3/8 NPT
Inlet Gas Pressure (in. of water)*		
Maximum	7"	7"
Minimum	5"	5"
Dimensions, Inches (H x W x D)		
Furnace	15 <sup>3</sup> / <sub>32</sub> x 16 <sup>1</sup> / <sub>8</sub> x 23 <sup>5</sup> / <sub>8</sub>	15 <sup>3</sup> / <sub>32</sub> x 21 <sup>3</sup> / <sub>4</sub> x 23 <sup>5</sup> / <sub>8</sub>
Weight (pounds)		
Furnace	53	71
Shipping	65	98

\* For purposes of input adjustment.

## PRODUCT FEATURES

### HOT SURFACE IGNITOR

This furnace has an electronic ignitor. There is no standing pilot. No matches or batteries are required.

### THERMOSTATIC HEAT CONTROL

The thermostat is temperature sensitive. It automatically turns the furnace on and off. This results in the greatest heating comfort. This can also result in lower gas bills.

### LIMIT SWITCH

The limit switch shuts off the gas to the main burner if the furnace becomes too hot to operate safely.

# DYNAVENT®

## DIRECT-VENT NATURAL GAS HEATER

### INSTALLATION

Mounting hardware needed to mount furnace into wall is included with the furnace. No venting material is needed. You must furnish tools and all gas piping from the gas source to the furnace inlet.

**⚠ WARNING: A qualified service person must install furnace. Have service person inspect furnace before use and at least annually. Follow all local codes.**

**NOTICE: This furnace must be electrically grounded. Follow all local codes. In the absence of local codes, follow the *National Electric Code, ANS/NFPA 70 (U.S.)* or *Canadian Electrical Code Part I-CSA C22.1 (Canada)*.**

### CHECK GAS TYPE

Use only natural gas. If your gas supply is not natural gas, do not install furnace. Call dealer where you bought furnace for proper type furnace.

### INSTALLATION ITEMS

Before installing furnace, make sure you have all items below:

- electric drill
- drill bits
- Phillips screwdriver
- hammer
- pipe wrench
- stud locator or small finishing nails
- equipment shutoff valve (supplied)
- test gauge connection (see Figure 15, page 10)
- piping (check local codes)
- sealant (resistant to propane/LP gas)
- ground joint union
- sediment trap
- tee joint

### LOCATING FURNACE

This furnace is designed to be mounted in a wall that is 4 to 18 inches thick. You can also mount furnace in a window.

**⚠ WARNING: Do not install furnace in interior wall of building. You must install furnace in exterior wall of building. Rear of furnace must extend into open, outside air. This lets poisonous exhaust gases ventilate to the outdoors.**

**⚠ WARNING: Turn off electrical circuits that pass through the wall where you are going to install the furnace.**

**⚠ WARNING: Maintain the minimum clearances shown in Figure 1. If you can, provide greater clearances from floor, ceiling, and joining wall.**

**⚠ WARNING: Due to high temperatures, never install the furnace:**

- in an inside wall
- in a recreation vehicle
- in a window recessed in a thick wall (creating an alcove)
- in an alcove
- behind a door or where an open door would block normal airflow
- as a fireplace insert
- in high traffic areas
- near furniture or draperies
- in windy or drafty areas

**⚠ CAUTION: If you install the furnace in a home garage, locate furnace where moving vehicle will not hit it.**

For convenience and efficiency, install furnace:

- where there is easy access for operation, inspection, and service
- in a central location, near an electrical outlet
- where there is adequate clearance around vents outside

Before installing furnace, inspect the wall, floor, and outside areas. Make sure there are no pipes, wiring, or anything else that would interfere with furnace installation. If you are installing thermostat in a wall, make sure there are no pipes or wiring in the hollow wall above the furnace. The thermostat wires will pass through this wall from the attic.

### Minimum Clearances

Provide the following minimum clearances from furnace front cover to combustibles (as viewed from the front of furnace, see Figure 1):

- Below Front Cover: 6 inches
- Above Front Cover: 12 inches
- Adjoining Wall: 12 inches
- Front: 8 feet

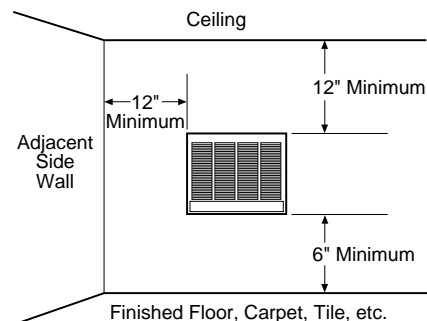

**Figure 1 - Mounting Clearances as Viewed from Front of Furnace**

The clearance between the cabinet and the wall it passes through is 0 inches.

Provide the following minimum clearances from furnace cabinet (portion of cabinet extending into outside air, as viewed from the rear of furnace) to obstructions:

- Cabinet Back: 36 inches
- Cabinet Sides: 6 inches

Cabinet Bottom: Must be high enough off the ground to prevent snow, water, leaves, or any other objects from blocking vents.

## INSTALLATION

(Continued)

### CREATING WALL OPENING AND MOUNTING FURNACE

Remove furnace front cover. Remove the two screws at the lower edges of front cover. Lift front cover away.

#### Installing in Normal Frame Wall

The 25,000 BTU/Hr model is designed to fit between two wall studs set at 16 inch on center. The 40,000 BTU/Hr model will not fit between wall studs. Follow the steps below to install.

1. Turn off electrical circuits that pass through mounting wall. Make sure there are no pipes or electrical wires in area you intend to cut.
2. Use stud locator or small finishing nail to find wall studs. When you locate studs, drive a small finishing nail into each stud. This provides a visual reference for stud locations.

3. **25,000 BTU/Hr Model:** Cut an opening in wall between the two studs. Make opening 14 1/4" wide by 13 5/8" high (see Figure 2). **IMPORTANT:** You must install furnace horizontally. Do not install furnace vertically.

**40,000 BTU/Hr Model:** Cut a 20 5/16" wide by 14 3/8" high opening in wall (see Figure 2). Start your cut right next to stud you are going to anchor cabinet to. Cut across wall and through the next stud. Stop cut at proper width. **IMPORTANT:** You must install furnace horizontally. Do not install furnace vertically.

4. **25,000 BTU/Hr Model:** Mark screw locations on wall (see Figure 2). Make sure screws will anchor into studs. Make sure screw locations match screw holes on cabinet flange.

**40,000 BTU/Hr Model:** Mark screw locations on wall (see Figure 2). Make sure screws on one side will anchor into studs. Screws on other side will only anchor in wall material. Make sure screw locations match screw holes on

cabinet flange.

5. **25,000 BTU/Hr Model:** Use a proper-sized drill bit. Drill holes through wall and into studs at marked locations.

**40,000 BTU/Hr Model:** Use a proper-sized drill bit. On wall stud side of opening, drill holes through wall and into studs at marked locations. On other side, drill holes through wall material.

6. Insert furnace into opening. Do this from inside the room. Secure furnace to wall with four large screws provided.
7. On outside of wall, caulk opening between the cabinet and the rough edges of opening.

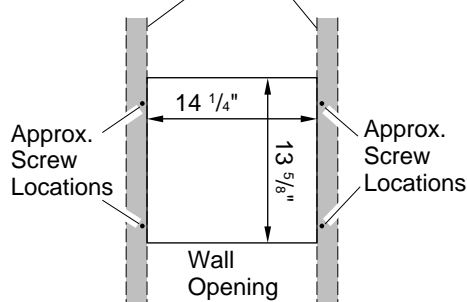

25,000 BTU/Hr Model

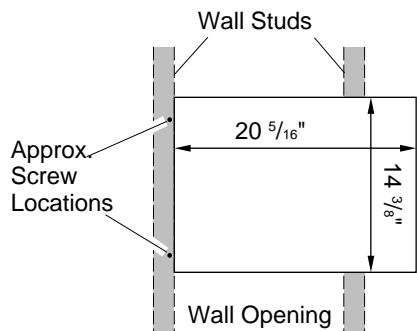

40,000 BTU/Hr Model

Figure 2 - Wall Openings and Screw Locations

#### Installing in Masonry Wall

You can mount both models in a masonry wall. Follow the steps below to install.

1. Cut opening in wall. Make opening 14 1/4" wide by 13 5/8" high for 25,000 BTU/Hr models. Make opening 20 5/16" wide by 14 3/8" high for 40,000 BTU/Hr models. **IMPORTANT:** You must install furnace horizontally. Do not install furnace vertically.

2. Secure furnace to wall with toggle bolts or hook bolts set in mortar.
3. Insert furnace into opening. Do this from inside the room. Secure furnace to wall with toggle bolts or hook bolts.
4. On outside of wall, caulk opening between the cabinet and the rough edges of opening. You can also use mortar to seal opening.

#### INSTALLING THERMOSTAT

**WARNING: Unplug furnace before installing thermostat.**

Mount the thermostat directly on the furnace or on a wall in another part of the room. If you have solid or masonry walls, mount the thermostat on the furnace.

#### Mounting Thermostat to Furnace

1. Unplug furnace.
2. Locate red and white thermostat wires coming out of side of furnace. These wires are labeled "Thermostat."
3. Cut thermostat wires to desired length.
4. Route thermostat wires through slot/hole in side of thermostat mounting plate. Then route wires through 5/8" diameter hole in center of plate (see Figure 4, page 6).
5. Connect thermostat wires to the two terminal screws on back of thermostat (see Figure 3). Connect red wire to "R" terminal. Connect white wire to "W" terminal.

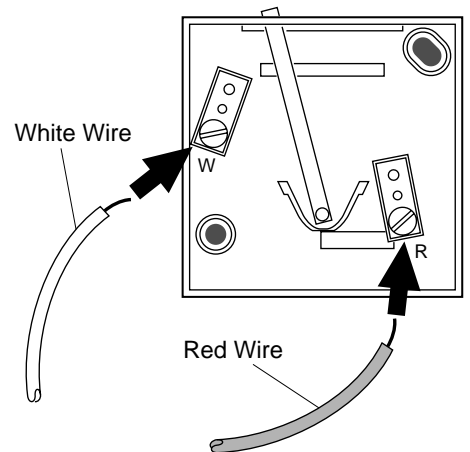

Figure 3 - Connecting Thermostat Wires to Thermostat

Continued

# DYNAVENT®

## DIRECT-VENT NATURAL GAS HEATER

### INSTALLATION

(Continued)

- Attach thermostat to thermostat mounting plate with screws provided (see Figure 4). **IMPORTANT:** Note mounting plate position in Figure 4. Correctly position mounting plate for your model furnace.
- Insert thermostat mounting plate between wall and cabinet flange. Line up top notch on mounting plate with top screw on flange (see Figure 5). **IMPORTANT:** Thermostat for 25,000 BTU/Hr model mounts on right side of furnace (see Figure 5). Thermostat for 40,000 BTU/Hr model mounts on left side of furnace (see Figure 5).
- Insert screw in cabinet flange and thermostat mounting plate and tighten firmly. **IMPORTANT:** Make sure thermostat wires do not touch combustion chamber.

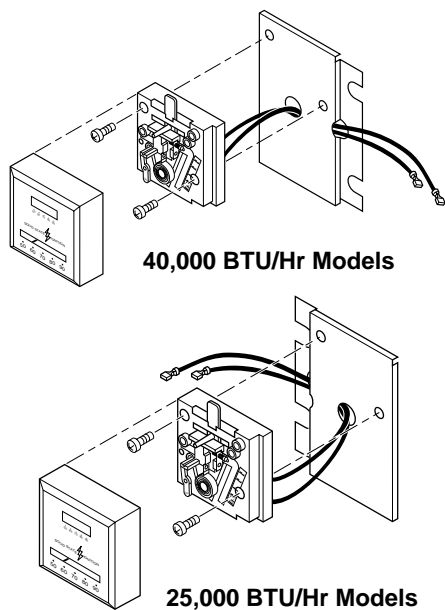
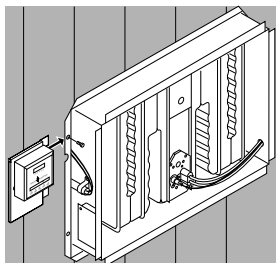
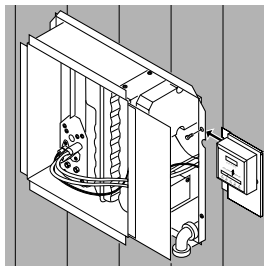

Figure 4 - Attaching Thermostat to Thermostat Mounting Plate



40,000 BTU/Hr Models



25,000 BTU/Hr Models

Figure 5 - Inserting Thermostat Mounting Plate Between Wall and Cabinet Flange

### Locating Thermostat on Wall

- Locate thermostat 4 1/2 to 5 feet above the floor on an inside wall away from any heat sources. The thermostat needs to sense average room temperature. Avoid the following:

#### HOT SPOTS

Concealed pipes or ducts  
Fireplaces  
Registers  
TV sets and radios  
Lamps or direct sunlight  
Kitchen

#### COLD SPOTS

Concealed pipes or ducts  
Stairwells (drafts) or doors (drafts)  
Unheated rooms on other side of wall

#### DEAD SPOTS

Behind doors  
Corners and alcoves

- Before installing thermostat, inspect the wall, floor, and attic areas. Make sure there are no pipes, wiring, or anything else that would interfere with installing thermostat. Do not mount thermostat to stud. If there are any obstructions, choose a new location.

- Provide two 18-gauge insulated stranded wires for the thermostat wire. Also provide two wire nuts, and two wall anchors. There is a red and a white thermostat wire coming from the furnace. The extra thermostat wires you furnish attach to these wires. Make sure you furnish a red and a white wire. This will insure correct hookup. Purchase enough thermostat wire to go from the furnace to the thermostat location. Do not cut and splice this wire. The thermostat wire must be unbroken.

### Routing Thermostat Cable

All wiring must meet local codes. The following instructions cover routing the wire through the attic. You can run wiring from a basement or crawl space.

- Unplug furnace.
- Before drilling hole in wall, drive a small finishing nail through ceiling directly above thermostat location. Pull nail out and push a small stiff wire through hole. This helps you locate thermostat mounting location when in attic.
- In attic, locate stiff wire. Drill 1/2" hole in center of ceiling wall plate next to stiff wire. Remove wire.
- Probe through drilled hole in wall plate with a stiff wire to make sure there are no pipes, wiring, or anything else blocking the way for thermostat wires. If you find blockage, choose new location for thermostat.
- Drill a 1/2" hole through the wall at thermostat mounting location.
- From attic, feed thermostat wires through hole in ceiling plate until wires reach thermostat location.
- Make a small hook with a piece of stiff wire. Run wire hook through 1/2" hole in wall. Hook thermostat wires. Pull wires through hole in wall. Make sure 6" of wires stick out.
- Drive a small finishing nail in ceiling above furnace.  
**25,000 BTU/Hr Model** - Drive nail above right side of furnace.  
**40,000 BTU/Hr Model** - Drive nail above left side of furnace. Pull nail out and push a small stiff wire through hole. This helps you locate wire routing location when in attic.
- Repeat steps 3 and 4 above.

## INSTALLATION

### (Continued)

10. Feed thermostat wires from attic to furnace through 1/2" hole in ceiling wall plate.
11. Connect thermostat wires from attic to thermostat wires on furnace. Connect red wires together, then connect white wires together. Use wire nuts to make connections. **IMPORTANT:** Make sure thermostat wires do not touch combustion chamber.

### Mounting the Thermostat to Wall

1. Connect thermostat wires to the two terminal screws on back of thermostat (see Figure 6). Connect red wire to "R" terminal. Connect white wire to "W" terminal.
2. Push any excess wire back through hole in wall and plug hole with insulation to prevent drafts. Drafts affect the thermostat operation.
3. Use thermostat base to mark mounting screw locations.
4. Drill proper-sized holes for wall anchors.
5. Attach thermostat to wall using screws provided (see Figure 7).

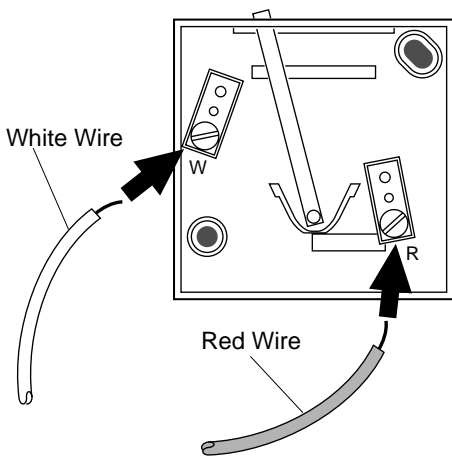

Figure 6 - Connecting Thermostat Wires to Thermostat

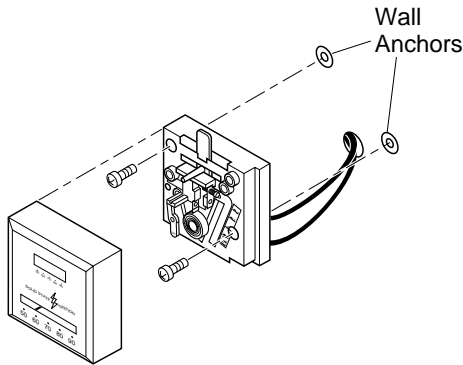

Figure 7 - Mounting Thermostat to Wall

## CONNECTING TO GAS SUPPLY

**WARNING:** A qualified service person must connect furnace to gas supply. Follow all local codes.

**WARNING:** Never connect furnace to private (non-utility) gas wells. This gas is commonly known as wellhead gas.

**WARNING:** Unplug furnace before connecting to gas supply.

**CAUTION:** Use only new, black iron or steel pipe. Copper tubing may be acceptable in certain areas. Check local codes. Use pipe large enough in diameter to allow proper gas volume to furnace. If pipe is too small, undue loss of pressure will occur. Refer to chart on page 9.

**CAUTION:** Lightly apply pipe joint sealant to male threads before connecting. Use pipe joint sealant that is resistant to liquid petroleum (LP) gas.

All piping must comply with local codes and ordinances or with the *National Fuel Gas Code (ANS Z223.1 NFPA No. 54)*, whichever applies.

You can connect furnace to gas supply at front of furnace (inside) or at rear of furnace (outside).

### Connecting Furnace to Gas Supply at Front of Furnace

1. Locate gas inlet pipe on lower, right front of furnace (see Figure 8).
2. Connect 3/8" NPT pipe or nipple to gas inlet pipe (see Figure 8). See *Providing Gas Piping to Furnace*, pages 9 and 10, for correct gas pipe installation.

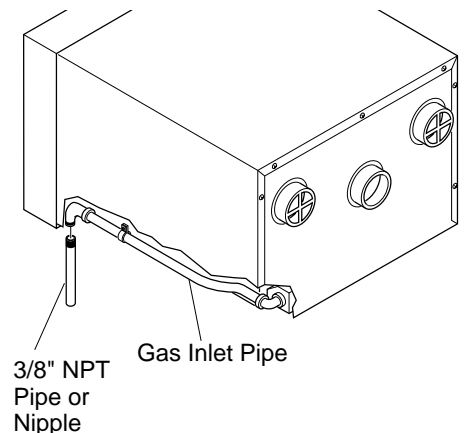

Figure 8 - Connecting Gas from Inside of Room

# DYNAVENT®

## DIRECT-VENT NATURAL GAS HEATER

### INSTALLATION

(Continued)

#### Connecting Furnace to Gas Supply at Rear of Furnace

1. Remove the two screws in back of furnace cabinet located by the exhaust vent(s) (see Figures 9 and 10).
2. Remove two screws on front lower flange that attach furnace flange to furnace cabinet flange (see Figure 11). *Note:* 40,000 BTU/Hr model has a bottom shield (see parts list, page 22, for location). Removing two screws will detach bottom shield.
3. Slide furnace out of furnace cabinet.
4. Locate gas inlet pipe on lower, right front of furnace.
5. **40,000 BTU/Hr Model Only:** Remove screw holding gas inlet pipe clamp to furnace.
6. Disconnect gas inlet pipe from 3/8" manifold elbow. Turn gas inlet pipe counterclockwise to disconnect (see Figure 12).
7. Rotate the 3/8" manifold elbow 90° so the opening is pointing downward (see Figure 12).
8. Locate knockout plug in furnace cabinet. Knockout plug is in lower left rear of furnace cabinet (as viewed from rear, see Figure 13). Remove knockout plug.
9. Slide furnace back into furnace cabinet. Make sure exhaust tube gaskets are in place. Make sure exhaust and intake vent tubes extend into vent caps on back of cabinet. Replace two screws by exhaust vent(s) removed in step 1.
10. **25,000 BTU/Hr Model:** Replace two screws removed in step 2. Attach furnace flange and furnace cabinet lower flange together.  
**40,000 BTU/Hr Model:** Place bottom shield back in place. Replace two screws removed in step 2. Attach bottom shield, furnace flange, and furnace cabinet lower flange together.

11. Run 3/8" pipe or nipple through knock-out hole. Connect 3/8" pipe or nipple to manifold elbow (see Figure 14). See *Providing Gas Piping to Furnace*, pages 9 and 10 for correct gas pipe installation.
12. Check connections for gas leak.

**⚠ WARNING: Never use an open flame to check for a leak. Apply a mixture of liquid soap and water to all joints. Bubbles forming show a leak. Correct all leaks at once.**

13. Caulk around pipe or nipple. This prevents cold air entering knockout hole.

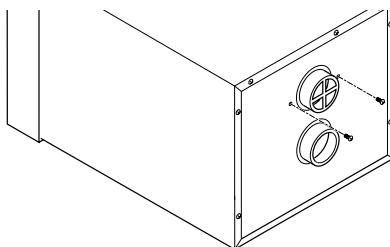

Figure 9 - Locations of Screws in Back of Furnace Cabinet (25,000 BTU/Hr Model)

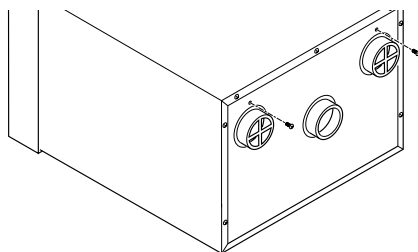

Figure 10 - Locations of Screws in Back of Furnace Cabinet (40,000 BTU/Hr Model)

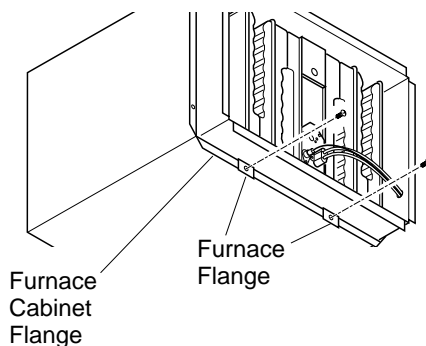

Figure 11 - Removing Screws on Lower Flange (40,000 BTU/Hr Model Shown)

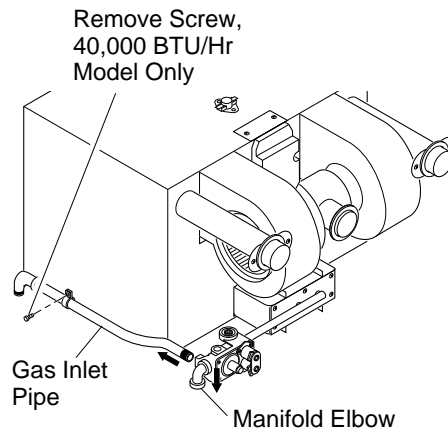

Figure 12 - Disconnecting Gas Inlet Pipe (40,000 BTU/Hr Model Shown)

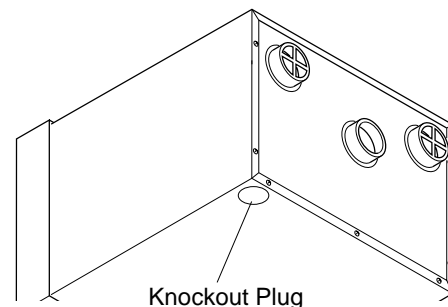

Figure 13 - Location of Knockout Plug

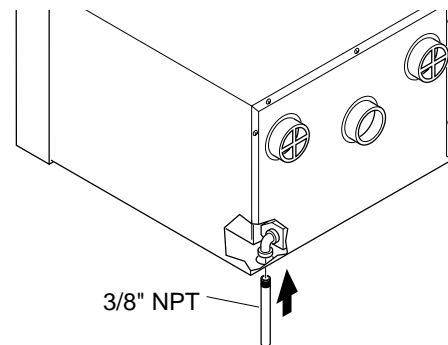

Figure 14 - Inserting Pipe through Knockout Hole



# OWNER'S MANUAL

## INSTALLATION

(Continued)

### Providing Gas Piping to Furnace

You must provide gas piping from gas source to furnace. The gas piping must be in a vertical position where it connects to the furnace. This prevents interference with front cover installation.

Consult your local gas company for proper routing of the gas lines.

Pipe size is determined by the length of pipe from the gas source to the furnace and the total BTU load on the gas source.

Add the total BTUs required for all appliances connected to the gas source including this furnace. Divide this number by 1030. This will give you the approximate cubic feet per hour needed.

*Example:*

40,000 BTU/Hr  
 + 15,000 BTU/Hr for other gas appliances  
 55,000 BTU/Hr total  
 55,000 ÷ 1030 = 53.4

Locate 53.4 or higher on chart below.

According to the chart below, you should use 50 feet or less of 1/2" pipe, 200 feet or less of 3/4" pipe, etc...

MINIMUM IRON PIPE SIZE	LENGTH OF PIPE (FEET)														
	10	20	30	40	50	60	70	80	90	100	125	150	175	200	
3/8"	72	49	40	34	30	27	25	23	22	21	18	17	15	14	
1/2"	132	92	73	63	56	50	46	43	40	38	34	31	28	26	
3/4"	278	190	152	130	115	105	96	90	84	79	72	64	59	55	
1"	520	350	285	245	215	195	180	170	160	150	130	120	110	100	
1 1/4"	1050	730	590	500	440	400	370	350	320	305	275	250	225	210	
1 1/2"	1600	1100	890	760	670	610	560	530	490	460	410	380	350	320	
2"	3050	2100	1650	1450	1270	1150	1050	990	930	870	780	710	650	610	
2 1/2"	4800	3300	2700	2300	2000	1850	1700	1600	1500	1400	1250	1130	1050	980	
3"	8500	5900	4700	4100	3600	3250	3000	2800	2600	2500	2200	2000	1850	1700	
4"	17500	12000	9700	8300	7400	6800	6200	5800	5400	5100	4500	4100	3800	3500	

**IMPORTANT:** Check gas line pressure at gas meter before connecting furnace to gas line. Gas line pressure must be no less than 5 inches of water and no greater than 7 inches of water. Gas pressures and input to the burners must not exceed the rated input and pressure shown on the rating plate. For natural gas, manifold pressure should be 3.5 inches of water. For elevations above 2000 feet, reduce rating 4% for each 1000 feet above sea level (U.S.A. only).

Continued

# DYNAVENT®

## DIRECT-VENT NATURAL GAS HEATER

### INSTALLATION

(Continued)

Installation must include an equipment shutoff valve (supplied), ground joint union, plugged 1/8" NPT tap, and a sediment trap. Locate NPT tap within reach for test gauge hook up. NPT tap must be upstream from furnace (see Figure 15).

Install an equipment shutoff valve in an accessible location. The equipment shutoff valve is for turning on or shutting off the gas to the appliance.

Apply pipe joint sealant lightly to male threads. Prevent excess sealant from going into pipe. Excess sealant in pipe could result in clogged furnace valves.

**CAUTION:** Use pipe joint sealant that is resistant to liquid petroleum (LP) gas.

Install sediment trap in supply line as shown in Figure 15. Locate sediment trap where it is within reach for cleaning. A sediment trap traps moisture and contaminants. This keeps them from going into furnace controls. If sediment trap is not installed or is installed wrong, furnace may not run properly.

**IMPORTANT:** Locate sediment trap where trapped matter will not freeze. Install sediment trap in a vertical run of pipe. If gas piping enters furnace from rear (outside), you must locate sediment trap in crawl space (see Figure 15). If you install furnace in structure with slab foundation, you must install gas piping to front of furnace (inside) (see Figure 15).

### CHECKING GAS CONNECTIONS

**WARNING:** Test all gas piping and connections for leaks after installation or servicing. Correct all leaks at once.

**WARNING:** Never use an open flame to check for a leak. Apply a mixture of liquid soap and water to all joints. Bubbles forming show a leak. Correct all leaks at once.

### Pressure Testing Gas Supply Piping System

Test Pressures In Excess Of 1/2 PSIG (3.5 kPa)

1. Disconnect appliance with its appliance main gas valve (control valve) and equipment shutoff valve from gas supply piping system. Pressures in excess of 1/2 psig (3.5 kPa) will damage heater regulator.
2. Cap off open end of gas pipe where equipment shutoff valve was connected.
3. Pressurize supply piping system by either using compressed air or opening main gas valve located on or near gas meter.
4. Check all joints of gas supply piping system. Apply mixture of liquid soap and water to gas joints. Bubbles forming show a leak.
5. Correct all leaks at once.
6. Reconnect furnace and equipment shutoff valve to gas supply. Check re-connected fittings for leaks.

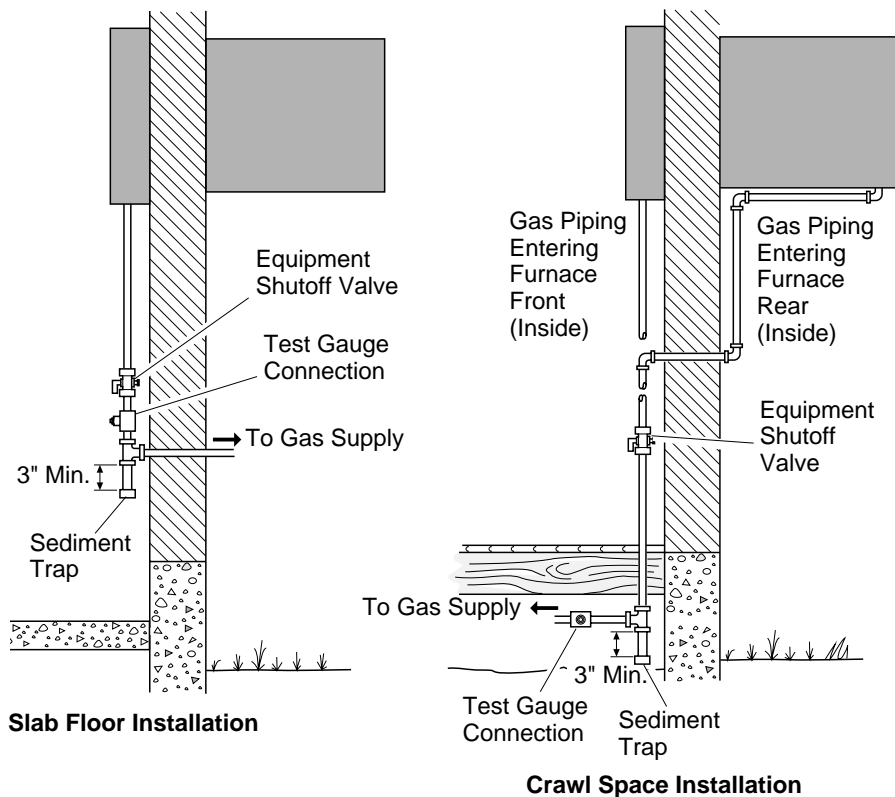

Figure 15 - Gas Connection

## INSTALLATION

(Continued)

### Test Pressures Equal To or Less Than 1/2 PSIG (3.5 kPa)

1. Close equipment shutoff valve (see Figure 16).
2. Pressurize supply piping system by either using compressed air or opening main gas valve located on or near gas meter.
3. Check all joints from gas meter to equipment shutoff valve. Apply mixture of liquid soap and water to gas joints. Bubbles forming show a leak.
4. Correct all leaks at once.

### Pressure Testing Furnace Gas Connections

1. Open equipment shutoff valve (see Figure 16).
2. Open main gas valve located on or near gas meter.
3. Make sure control knob of furnace is in the OFF position.
4. Check all joints from equipment shutoff valve to gas inlet pipe. Apply mixture of liquid soap and water to gas joints. Bubbles forming show a leak.
5. Correct all leaks at once.
6. Turn on furnace (see *Operating Furnace*, pages 12 and 13). Check the rest of the internal joints for leaks.
7. Turn off furnace (see *To Turn Off Gas to Furnace*, page 13).

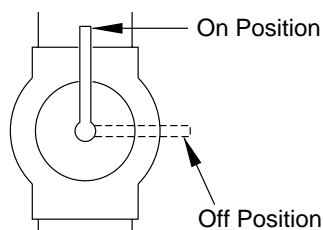

Figure 16 - Equipment Shutoff Valve

## CONNECTING TO ELECTRICAL SUPPLY

**IMPORTANT:** Follow all local codes when connecting electricity to furnace. In the absence of local codes, refer to the latest edition of the *National Electrical Code ANS/NFPA No. 70*. If you are not familiar with wiring codes, have a qualified electrician do the wiring.

It is best to plug furnace into a separate and permanent electrical line circuit.

1. Supply a 120-volt, 60-cycle, grounded outlet at furnace location.
2. The furnace has a three-pronged (grounded) plug. Use only a grounded, three-prong outlet.

**IMPORTANT:** Some local codes require rigid or semi-rigid conduit or metallic sheathe cable. When using a semi-rigid or metallic sheathe cable, the installer must terminate the supply wire in the terminal box opening.

### Performance Check

Plug furnace into three-pronged outlet. If ignitor remains on after main burner ignition or if the valve chatters, you may have reversed polarity.

1. Unplug furnace.
2. Turn off electricity to outlet.
3. Reverse 120-volt connections inside outlet.
4. Turn on electricity to outlet.
5. Plug in furnace. Ignitor should turn off after main burner ignites. If ignitor does not turn off, or if valve continues to chatter, turn off furnace and unplug. Call a qualified service person.

## ATTACHING CABINET FRONT COVER

**CAUTION:** Do not operate furnace with front cover removed or mounted wrong. If front cover is mounted wrong, you cannot secure it to cabinet with screws.

1. Hook top of front cover over top cabinet flange.
2. Secure the sides of front cover to lower sides of furnace cabinet with two screws provided (see Figure 17).

**IMPORTANT:** You may have removed furnace from furnace cabinet during installation. You must correctly install furnace within cabinet. If not, front cover will not properly attach to cabinet. Make sure gaskets for intake and exhaust tubes are in place. Make sure intake and exhaust tubes extend into vent caps on cabinet back and are secured with screws. Make sure you secured flange on bottom of furnace to flange on bottom front of cabinet.

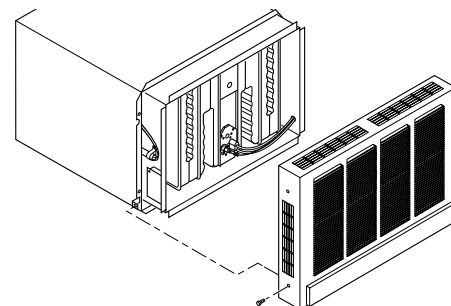

Figure 17 - Attaching Front Cover to Cabinet

# DYNAVENT®

## DIRECT-VENT NATURAL GAS HEATER

### OPERATING FURNACE

**⚠ WARNING:** Furnace burner, combustion chamber, and exhaust port are very hot during operation. Keep children and adults away from hot surfaces to avoid burns and clothing ignition. Carefully supervise young children when they are in the same room as furnace. Furnace will remain hot for a time after shutdown. Let surface cool before touching.

**⚠ WARNING:** Do not operate furnace with front cover removed. Unsafe operation could result.

**⚠ CAUTION:** Do not block circulating air openings in the louver of the front cover. This is necessary for furnace to operate properly.

**NOTICE:** If operating furnace for the first time, a slight odor will occur. This odor will go away after a few hours of operation.

#### FOR YOUR SAFETY READ BEFORE LIGHTING

**⚠ WARNING:** If you do not follow these instructions exactly, a fire or explosion may result causing property damage, personal injury, or loss of life.

A. This appliance does not have a pilot. It is equipped with an ignition device which automatically lights the burner. Do not try to light the burner by hand.

B. **BEFORE OPERATING** smell all around the appliance area for gas. Be sure to smell next to the floor because some gas is heavier than air and will settle on the floor.

#### WHAT TO DO IF YOU SMELL GAS

- Do not try to light any appliance.
- Do not touch any electric switch; do not use any phone in your building.
- Immediately call your gas supplier from a neighbor's phone. Follow the gas supplier's instructions.
- If you cannot reach your gas supplier, call the fire department.

C. Use only your hand to turn the handle on the equipment shutoff valve. Never use tools. If the handle will not turn by hand, don't try to repair it. Call a qualified service technician. Force or attempted repair may result in a fire or explosion.

D. Do not use this appliance if any part has been under water. Immediately call a qualified service technician to inspect the appliance and to replace any part of the control system and any gas control which has been under water.

### OPERATING INSTRUCTIONS

**⚠ WARNING:** Always follow lighting instructions. Never attempt to light burner with a match or butane torch.

1. **STOP!** Read the safety information, column 1.
2. Set the thermostat to lowest setting.
3. Turn off all electric power to the furnace.
4. Turn equipment shutoff valve clockwise  to OFF position (see Figure 18).

5. Wait five (5) minutes to clear out any gas. Then smell for gas, including near the floor. If you smell gas, **STOP!** Follow "B" in the safety information, column 1. If you don't smell gas, go to next step.

6. Turn equipment shutoff valve counterclockwise  to ON position (see Figure 18).

7. This furnace is equipped with an ignition device which automatically lights the burner. Do not try to light the burner by hand.

8. Plug in furnace.

9. Set thermostat to desired setting. If thermostat is set above room temperature, the blower will come on.

10. Allow approximately 45 seconds for ignition to occur. When ignition occurs, the glo-bar will stay on for a short period of time. The flame sensing probe will sense the burner flame and shut off glo-bar.

If ignition does not occur within 22 seconds, the ignition control will attempt to light burner three times. This will take about two minutes. If ignition does not occur, the ignition control will lock out the glo-bar and valve circuit. Air in the gas line or a short gas interruption will prevent furnace from igniting. If this happens, turn thermostat off and wait 5 minutes. Turn the thermostat back on. The furnace will try to ignite again.

11. If the furnace still does not ignite, follow instructions *To Turn Off Gas to Furnace*, page 13. Call a qualified service person. Do not attempt to restart furnace.

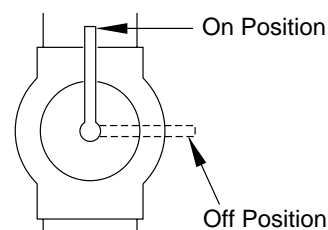

Figure 18 - Equipment Shutoff Valve

## OPERATING FURNACE

(Continued)

### TO TURN OFF GAS TO FURNACE

1. Set thermostat to lowest setting
2. Turn equipment gas valve clockwise to OFF position. Do not force equipment gas valve.
3. Unplug furnace if service is to be performed.

### To Shut Down Furnace for an Extended Period of Time

1. Turn equipment gas valve clockwise to OFF position. Do not force equipment gas valve.
2. Set thermostat on OFF.

**CAUTION:** Do not try to adjust heating levels by using the equipment shutoff valve.

### THERMOSTAT CONTROL OPERATION

The thermostat responds to the room temperature. When the room temperature drops below the thermostat setting, the thermostat turns the furnace burner and blower on. When the room temperature goes above the thermostat setting, the thermostat turns the furnace burner off. The blower will continue to blow about two to three minutes after the burner goes out. The thermostat keeps the room at a constant temperature.

## INSPECTING BURNER FLAME

To observe burner flame, remove furnace front cover. Remove the two screws at the lower edges of front cover. Lift front cover away. Locate viewing window on front of combustion chamber. You can see burner flame through this window.

**Correct Burner Flame:** Blue flame with well-defined burner ports.

**Incorrect Burner Flame:** Yellow or lazy flame without well-defined burner ports.

If burner flame is incorrect, shut off furnace and contact a qualified service person.

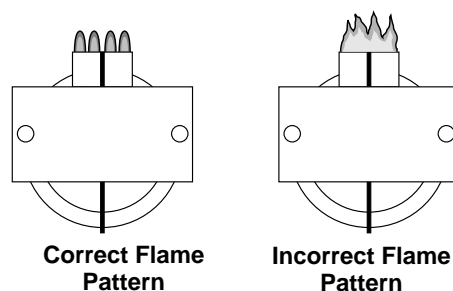

Figure 19 - Burner Flame Patterns

## NORMAL OPERATING SEQUENCE

1. When the room temperature drops below the thermostat setting, the thermostat calls for heat. A 24-volt circuit is completed through the time delay relay coil. After three to five seconds, the contacts in the relay close. The blowers come on.
2. One motor drives both the combustion air blower and the circulating room air blower. The combustion air blower draws air from outside through the intake air vent. This air discharges into the combustion chamber. The combustion air blower then forces the combustion products out of the exhaust tube(s). The Combustion air blower is sealed so that air does not pass between it and the circulating room air blower.
3. When the blower motor reaches 75% of normal r.p.m. (three to five seconds), air from the blower turns on the

microswitch. When the microswitch activates, the electrical circuit is completed through the limit switch to the control module. The glo bar begins to glow. In about 15 seconds, the glo bar becomes hot enough to ignite the burner.

4. Another 24-volt circuit is completed through the module to the main gas valve. The valve opens. Gas passes through the valve to the main burner. The gas is ignited by the glo bar.
5. After the main burner ignites, the flame detector senses the presence of flame. This opens the circuit to the glo bar. The glo bar shuts down.
6. The circulating room air blower pulls return air in from the living area. This air is heated as it flows past the combustion chamber. The heated air is then blown out into the room.
7. When the room temperature rises above the thermostat setting, the circuit to the valve opens and the burner shuts off.
8. The blower continues to run about two to three minutes until the time delay relay coil cools. When the coil cools, the circuit to the motor opens. The blower shuts off.

## LIMIT SWITCH

**WARNING:** Do not operate furnace without a properly-working limit switch.

The limit switch will turn off the gas to the main burner if the furnace becomes too hot. When this happens, the main burner will go out and the blower will continue to run for two to three minutes. This usually happens when circulating air is partially or completely blocked.

Occasional cycling of the limit switch is not bad. This indicates safe operation. Limit switch cycling will most likely occur on warm days. If this happens too often or for a long period of time, the circulating air system should be thoroughly cleaned by a qualified service person.

If the circulating air system is cleaned and the limit switch continues to shut down the furnace, the limit switch is defective. A defective limit switch cannot be repaired. It must be replaced. For safety reasons, never operate the furnace without a limit switch.

# DYNAVENT®

## DIRECT-VENT NATURAL GAS HEATER

---

### CLEANING AND MAINTENANCE

**⚠ WARNING:** Turn off and unplug furnace and let cool before cleaning. Turn equipment shutoff valve to OFF position. Only a qualified service person should service and repair furnace.

**⚠ WARNING:** Keep furnace clear and free from combustible materials, gasoline, and other flammable vapors and liquids.

**⚠ CAUTION:** You must keep control areas, burner, and circulating air passageways of furnace clean. Inspect these areas of furnace before each use. Have furnace inspected yearly by a qualified service person. Furnace may need more frequent cleaning due to excessive lint from carpeting, bedding material, pet hair, etc.

**⚠ CAUTION:** Label all wiring prior to disconnection when servicing controls. Wiring errors can cause improper and dangerous operation.

Verify proper operation after servicing.

### CABINET

#### Air Passageways

- Use a vacuum cleaner or pressurized air to clean.

#### Exterior

- Use a soft cloth dampened with a mild soap and water mixture. Wipe cabinet and front cover to remove dust.
- Use a vacuum cleaner to remove dust from front cover louvers.

### EXHAUST AND INTAKE VENTS

Make sure the exhaust and intake vents are not blocked. The intake combustion air and the exhaust gases must be expelled to the outside. Have a qualified service person clean dirt and loose debris from vents annually.

### GASKETS

Inspect all gaskets. If any gaskets show signs of leakage or damage, replace them. Safe operation of furnace depends on all gaskets being tight.

### FRONT COVER

Remove anything that may be blocking the air to the louvers of the front cover.

### COMBUSTION CHAMBER AND MAIN BURNER

Check flame pattern of main burner often (see *Inspecting Burner Flame*, page 13). Have combustion chamber and main burner cleaned if you have run the furnace with a high yellow flame. Incomplete combustion from lack of air causes the yellow flame. This deposits soot inside the combustion chamber and on the burner. Contact a qualified service person to clean combustion chamber and main burner.

### OUTSIDE VENT CAPS

Inspect outside vent caps for obstructions or soot. If soot is found, do not use furnace. Contact a qualified service person to clean furnace.

# OWNER'S MANUAL

## TROUBLESHOOTING

*Note:* For additional help, visit DESA International's technical service web site at [www.desatech.com](http://www.desatech.com).

**⚠ WARNING:** Turn off and unplug furnace and let cool before servicing. Unless you need gas supply for testing, shut off equipment shutoff valve before servicing. Only a qualified service person should service and repair furnace.

*Note:* All troubleshooting items are listed in order of operation.

OBSERVED PROBLEM	POSSIBLE CAUSE	REMEDY
No heat	<ol style="list-style-type: none"><li>1. Thermostat off</li><li>2. Gas supply</li><li>3. Electrical connections and power</li><li>4. Motor</li> <li>5. Malfunctioning microswitch</li> <li>6. Gas valve</li></ol>	<ol style="list-style-type: none"><li>1. Check to be sure thermostat is calling for heat. Wire to thermostat could be off terminal</li><li>2. Be sure equipment gas valve is in the open position (level or parallel to gas line)</li><li>3. Be sure all electrical connections are secure</li><li>4. Motor must be operating at top speed before burner will come on. If blower is not operating at top speed, check voltage supply (minimum 100 volts A.C.). If voltage supply is okay, check for defective motor</li><li>5. Be sure the microswitch is sailing in far enough to open the solenoid valve and to energize the ignition control. If the switch is not sailing in, clean any dust or dirt from the actuator pin. Other reasons for the switch not sailing in are<ol style="list-style-type: none"><li>A. Insufficient blower speed - Slow motor due to faulty motor or lint and dust accumulation on the blower wheels or restriction of return air to the furnace</li><li>B. Faulty microswitch - Replace switch if circuit to ignition control is not completed when switch is manually engaged. Switch should also be replaced if blower motor running at top speed fails to engage switch within six or seven seconds. <i>Note:</i> To service switch, combustion chamber must be pulled out. Follow steps 1, 2, 3, 9 and 10 on page 8 to remove combustion chamber</li></ol></li><li>6. Within 20 seconds after motor reaches 75% of its r.p.m. and microswitch engages, check the following:<ol style="list-style-type: none"><li>A. Voltage at valve - If current is present but valve is not opening, check wire connections</li><li>B. If wire connections okay - Replace valve</li><li>C. No voltage at valve - Check circuit completion through microswitch and limit switch as well as wiring and wire connections. If no defects are found, see <i>Ignition Failures</i>, page 16</li></ol></li></ol>

# DYNAVENT®

## DIRECT-VENT NATURAL GAS HEATER

### TROUBLESHOOTING

*Continued*

OBSERVED PROBLEM	POSSIBLE CAUSE	REMEDY
No heat ( <i>continued</i> )	7. Blower not operating	7. A. Check power supply to furnace B. Check electrical connections at furnace C. With thermostat points closed, check for circuit completion at motor. If voltage is present, replace motor. If no voltage is present at motor, check for: <ul style="list-style-type: none"><li>• 24 volts on secondary coil or transformer. If no voltage, replace transformer.</li><li>• If 24 volt transformer okay, check for circuit completion across contacts on time delay relay. Allow three to five seconds for contact to close</li><li>• If circuit across contacts okay, check continuity of wiring in motor circuit</li></ul>
	8. Short cycling (motor goes on and off)	8. A. Check thermostat. Contacts should remain closed. If contacts are breaking: <ul style="list-style-type: none"><li>• Check thermostat anticipator setting. It should be between .75 and 1.0</li><li>• If anticipator setting okay, check amp draw across thermostat. If amp draw exceeds .65, check amp draw across coil of valve and time delay relay. <b>Note:</b> On initial operation of glo bar, there is a momentary surge of approximately 4.0 amps</li><li>• If amp draw is within limits, check for shorts in thermostat wiring</li><li>• If wiring is okay, replace thermostat</li></ul>

### IGNITION FAILURES

#### WARNINGS:

- Never connect unit or ignition circuit to 230 volts.
- Never operate unit with glo bar touching burner or any other ground. Damage to ignition control will occur.
- Be sure sensor probe never touches glo bar. This will damage ignition control.
- If the ignition control is defective, it must be replaced. It is not field-repairable.

 **CAUTION:** Do not attempt to repair the ignition control. This may alter it and cause it to operate incorrectly.

The electronic system is made up of two parts: the ignition control and the glo bar. The ignition control is the brain of the electronic system. It has several functions:

1. When the blower reaches full r.p.m., a 24-volt circuit is completed to the ignition control. (Check across yellow and orange wires.)
2. The red and blue wires at the ignition control are the 120-volt input for the glo-bar circuit. When the 24-volt circuit is completed, the ignition control will complete the 120-volt circuit to the glo bar and it begins to glow. (Check this circuit across the two white wires at the ignition control.)
3. After approximately 20 seconds, a 24-volt circuit is completed through the ignition control to the gas valve. (This circuit is checked from brown wire at ig-

nitiation control to a neutral ground.) This circuit opens the valve, gas flows to the burner and is ignited by the heat from the glo bar. **Note:** Glo bar remains on.

4. When the burner flame is established, the sensing probe will sense the presence of burner flame and open the glo-bar circuit. The glo bar will then stop glowing.

It is important to determine the type of problem being experienced. Then the proper checkout procedure can be made. The following is a list of problems, how to identify in which area the problem is located, and how to correct it.



# OWNER'S MANUAL

## TROUBLESHOOTING

### Continued

OBSERVED PROBLEM	POSSIBLE CAUSE	REMEDY
Ignition failures	1. Glo bar will not glow - with blower running and microswitch engaged	1. Check the following: A. Check for 24 volts A.C. across yellow and orange wires at ignition control. If no voltage, check microswitch and limit switch for circuit completion as well as wiring and wiring connections B. Voltage present across yellow and orange wires, check for 120-volt input to ignition control across red and blue wires. If no voltage, check wiring all the way back to power supply C. 120 volts present across red and blue wires, check for 120 volts across the two white wires at ignition control. If no voltage, replace ignition control D. Voltage present across the two white wires, check wiring and wire connections to glo bar E. If wiring and wire connections okay, replace glo bar. (Glo bar broken)
	2. Glo bar glows but burner will not come on	2. A. Check for voltage (24 volts A.C.) at valve 40 seconds after glo bar begins to glow. If voltage present but valve not opening, replace valve B. If no voltage at valve, check brown wire at ignition control for continuity and good connection C. If wire and wire connections okay, replace ignition control
	3. Glo bar operating and gas valve opening but burner will not light	3. A. Check gas flow through burner. If no gas is coming through burner, check for obstruction in gas line, main burner orifice, or main burner B. If thermostat okay, check for 24 volt A.C. circuit completion across yellow and orange wires at ignition control. If no voltage, check for circuit completion through limit switch and microswitch C. If voltage is present at ignition control across yellow and orange wires yet burner continues to go off, replace ignition control
	4. If the ignitor remains on after main burner ignition or the valve chatters, reverse the 120-volt A.C. connections at the wall receptacle	4. A. If polarity is okay yet burner continues to go off, check thermostat to be sure it is still completing the valve circuit. If not, check for excessive amp draw in valve circuit B. If thermostat okay, check for 24 volt A.C. circuit completion across yellow and orange wires at ignition control. If no voltage, check for circuit completion through limit switch and microswitch C. Voltage present at ignition control across yellow and orange wires yet burner continues to go off, replace ignition control

# DYNAVENT®

## DIRECT-VENT NATURAL GAS HEATER

---

### TROUBLESHOOTING

*Continued*

OBSERVED PROBLEM	POSSIBLE CAUSE	REMEDY
Ignition failures	5. Burner cycles off and glo bar comes on immediately, check the following:	5. A. Check flame sensing probe. Be sure probe is positioned in the burner flame and glowing cherry red. Check wire and wire connections at probe and ignition control B. If wire and wire connections okay, check for voltage across brown and orange wires at ignition control. If no voltage, replace ignition control C. If voltage present, check wiring and wire connections at valve D. If wire and wire connections okay, replace valve
Excessive noise	1. Blower out of balance 2. Motor hums	1. Replace blower 2. Replace motor
Main burner will not cycle off	1. Thermostat setting 2. Gas valve stuck open	1. Check thermostat 2. Check gas valve. If stuck open, replace. Do not attempt to repair valve!
Furnace will not operate	1. Wiring connections or shorts	1. Check all wiring to assure proper connection or detect possible shorts

# OWNER'S MANUAL

## WIRING DIAGRAMS

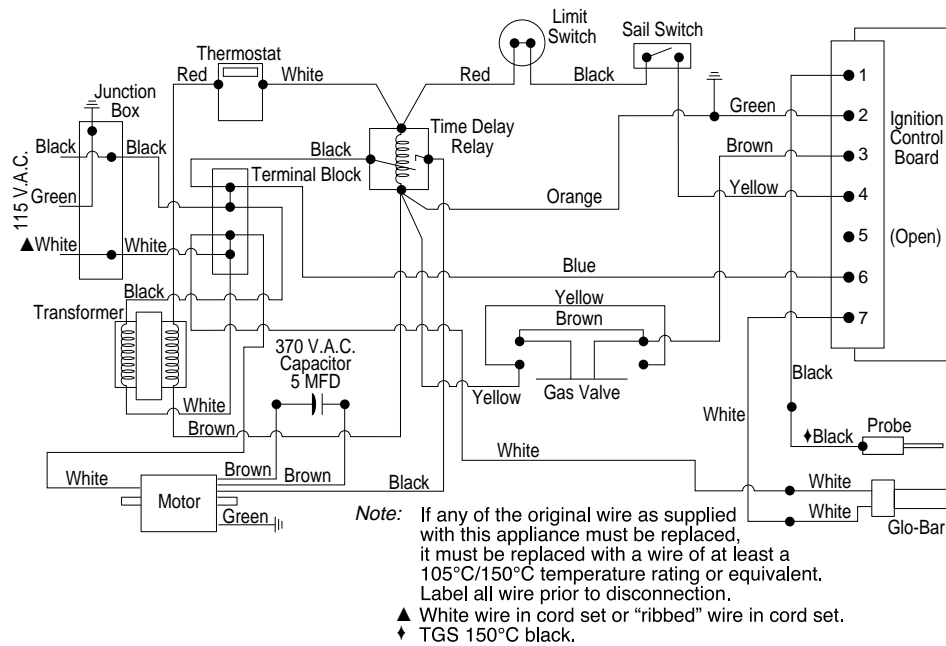

Figure 20 - Wiring Diagram (25,000 BTU/Hr Model)

## REPLACEMENT PARTS

Note: Use only original replacement parts. This will protect your warranty coverage for parts replaced under warranty.

### PARTS UNDER WARRANTY

Contact authorized dealers of this product. If they can't supply original replacement part(s), call DESA International's Technical Service Department at 1-800-323-5190. When calling DESA International, have ready:

- your name
- your address
- model and serial number of your furnace
- how furnace was malfunctioning
- type of gas used (propane/LP or natural gas)
- purchase date

Usually, we will ask you to return the defective part to the factory.

### PARTS NOT UNDER WARRANTY

Contact authorized dealers of this product. If they can't supply original replacement part(s), either contact your nearest Parts Central (see below) or call DESA International's Parts Department at 1-800-972-7879. When calling DESA International, have ready:

- model number of your furnace
- the replacement part number

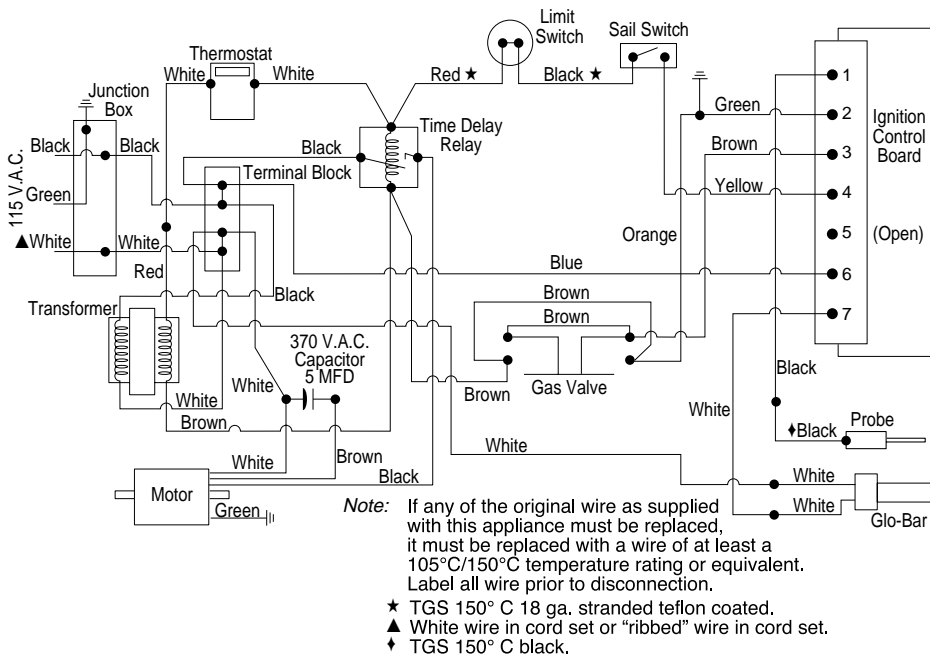

Figure 21 - Wiring Diagram (40,000 BTU/Hr Model)

# DYNAVENT®

## DIRECT-VENT NATURAL GAS HEATER

---

### SERVICE HINTS

#### When Gas Pressure Is Too Low

- glo-bar glows, but burner will not ignite

#### When Gas Quality Is Bad

- burner will not stay lit
- burner will produce flames and soot

You may feel your gas pressure is too low or gas quality is bad. If so, contact your local gas supplier.

### PARTS CENTRALS

#### Howard Industries

8855 Washington Blvd.  
Culver City, CA 90232  
310-837-9100  
www.howind.com

#### Victor Manufacturing

42 Rumsey Road  
E. Hartford, CT 06108-1164  
NY, NJ, DE, PA, MD  
1-800-243-9360  
203-289-4223  
Fax: 1-800-274-2004  
www.fwwebb.com

#### Controlled Engineering

299 Roosevelt Road  
Glen Ellyn, IL 60137-5618  
630-469-7300  
www.controld.com

#### Portable Heater Parts

342 N. Country Road 400E  
Valparaiso, IN 46383-9704  
1-800-362-6951  
219-462-7441  
www.portableheaterparts.com  
sales@portableheaterparts.com  
techservice@portableheaterparts.com

#### F B D

1349 Adams Street  
Bowling Green, KY 42103-3414  
1-800-654-8534  
(270) 846-1199  
Fax: 1-800-846-0090  
franktalk@aol.com

### TECHNICAL SERVICE

You may have further questions about installation, operation, or troubleshooting. If so, contact DESA International's Technical Service Department at 1-800-323-5190.

You can also visit DESA International's technical service web site at [www.desatech.com](http://www.desatech.com).

These Parts Centrals are privately owned businesses. They have agreed to support our customer's needs by providing original replacement parts and accessories. For certain parts, some Parts Centrals may refer you to a dealer in your area. When calling a Parts Central, ask for the Parts Department.

#### Master Parts Dist.

1251 Mound Ave. NW  
Grand Rapids, MI 49504-2672  
1-800-446-1446  
616-791-0505  
Fax: 616-791-8270  
www.nbmc.com

#### Washer Equipment Co.

1715 Main Street  
Kansas City, MO 64108-2195  
KS, MO, AR  
816-842-3911

#### Controls, Inc.

6820 Glenwood Ave.  
Raleigh, NC 27612-7133  
NC, SC, VA, MD  
1-800-334-5886  
919-787-2242

#### Tarantin Tank Co.

P.O. Box 6129  
Freehold, NJ 07728-6129  
1-800-922-0724  
908-780-9340  
www.tarantin.com

#### East Coast Energy

707 Broadway  
W. Long Branch, NJ 07764-1542  
1-800-755-8809  
732-870-8809  
www.njplaza.com/ecep

#### Dayton Hardware

P. O. Box 275  
North Dayton Station  
Dayton, OH 45404-0275  
Ohio Only - 1-800-762-3426  
937-258-3721

#### Central Air Supply

424 North Rockwell  
Oklahoma City, OK 73127-6119  
405-495-0014

#### Halco Enterprises

208 Carter Drive, Unit 21  
West Chester, PA 19382-4500  
1-800-368-0803  
610-430-7717  
www.halcoenterprises.com

#### Laportes Parts & Service

2444 N 5th Street  
Hartsville, SC 29550-7704  
803-332-0191

#### Cans Unlimited, Inc.

P. O. Box 649  
Taylor, SC 29687-0013  
1-800-845-5301  
803-879-3009  
cuisales@aol.com

#### Hughes Supply

1311 S Fern Street  
Arlington, VA 22202-2809  
703-416-8555

#### Tuco Industrial Products

5223 180th St. SW, Suite 4A-1  
Lynwood, WA 98037-4506  
1-800-735-1268  
425-743-9533  
www.tucoheat.com

#### Auer Steel & Heating Supply

2935 W. Silver Spring Dr.  
Milwaukee, WI 53209-4224  
414-463-1234  
www.auersteel.com

# OWNER'S MANUAL

## ILLUSTRATED PARTS LIST

### CABINET ASSEMBLY 25,000 BTU/HR MODEL

This list contains replaceable parts used in your furnace. When ordering parts, follow the instructions listed under *Replacement Parts* on page 19 of this manual.

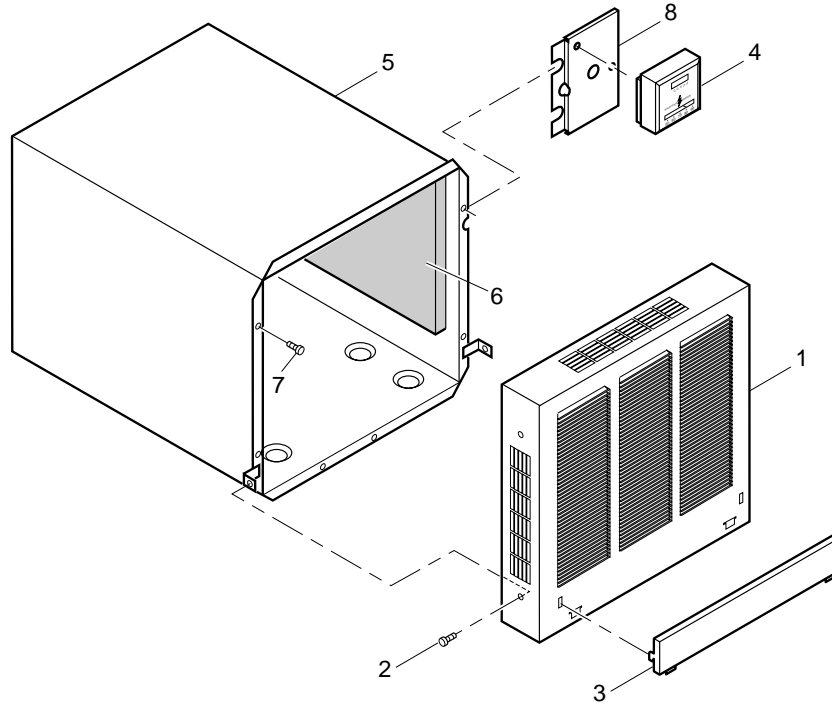

KEY NO.	PART NUMBER	DESCRIPTION	QTY.
1	030643	Front Cover Assembly	1
2	121520	Screw, #8 x 3/8" **	2
3	191240	Front Cover Trim*	1
4	160912	Thermostat	1
5	100892	Cabinet Assembly	1
6	070509	Cabinet Insulation (right and left sides)	1
7	121224	Screw, #10 x 3/4" **	4
8	062242	Thermostat Mounting Plate	1
Δ	070542	Cabinet Insulation (back)	1
Δ	070508	Cabinet Insulation (top)	1
Δ	191244	Operating Instructions Decal (English)	1
Δ	191246	Operating Instructions Decal (French)	1
Δ	531010	Warning Decal	1
Δ	191262	Nameplate	1

Δ Parts available, not shown.

\* You must order nameplate and operating instructions decal separately.

\*\* Standard hardware, can be picked up at local hardware store.

# DYNAVENT®

## DIRECT-VENT NATURAL GAS HEATER

### ILLUSTRATED PARTS LIST

This list contains replaceable parts used in your furnace. When ordering parts, follow the instructions listed under *Replacement Parts* on page 19 of this manual.

#### CABINET ASSEMBLY 40,000 BTU/HR MODEL

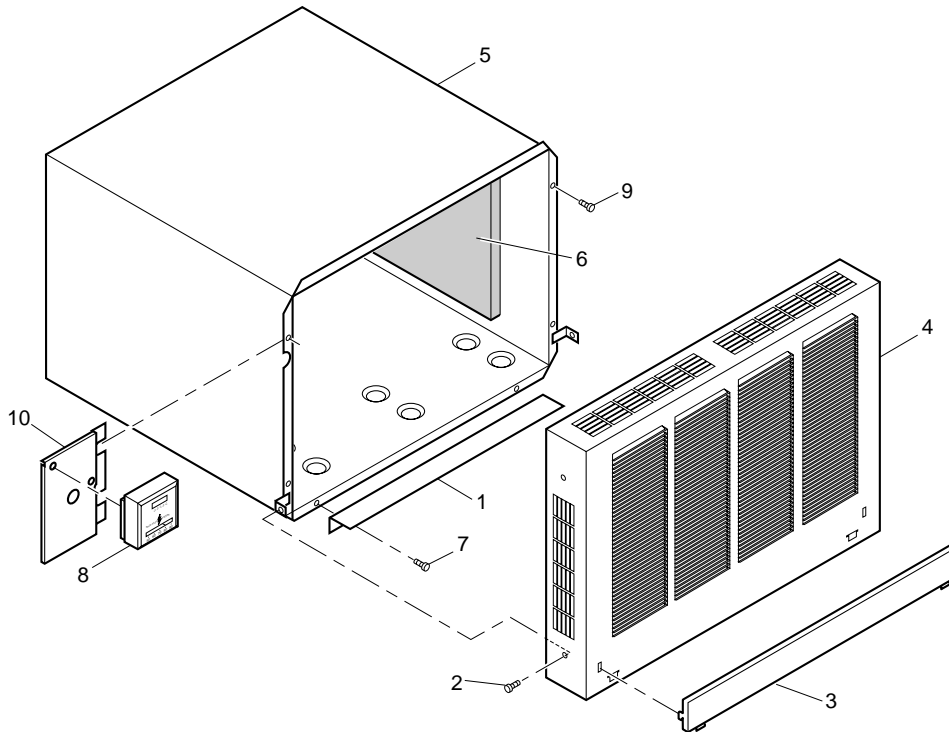

KEY NO.	PART NUMBER	DESCRIPTION	QTY.
1	280498	Bottom Shield	1
2	121520	Screw, #8 x 3/8" **	2
3	191241	Front Cover Trim*	1
4	030642	Front Cover Assembly	1
5	100896	Cabinet Assembly	1
6	070511	Cabinet Insulation (right and left sides)	1
7	120158	Screw, #8 x 3/8" **	2
8	160912	Thermostat (includes 2 screws)	1
9	121224	Screw, #10 x 3/4" **	4
10	062242	Thermostat Mounting Plate	1
Δ	070541	Cabinet Insulation (back)	1
Δ	070510	Cabinet Insulation (top)	1
Δ	191245	Operating Instructions Decal (English)	1
Δ	191247	Operating Instructions Decal (French)	1
Δ	531010	Warning Decal	1
Δ	191262	Nameplate	1

Δ Parts available, not shown.

\* You must order nameplate and operating instructions decal separately.

\*\* Standard hardware, available at local hardware store.

# OWNER'S MANUAL

## ILLUSTRATED PARTS LIST

This list contains replaceable parts used in your furnace. When ordering parts, follow the instructions listed under *Replacement Parts* on page 19 of this manual.

### COMBUSTION CHAMBER ASSEMBLY 25,000 BTU/HR MODEL

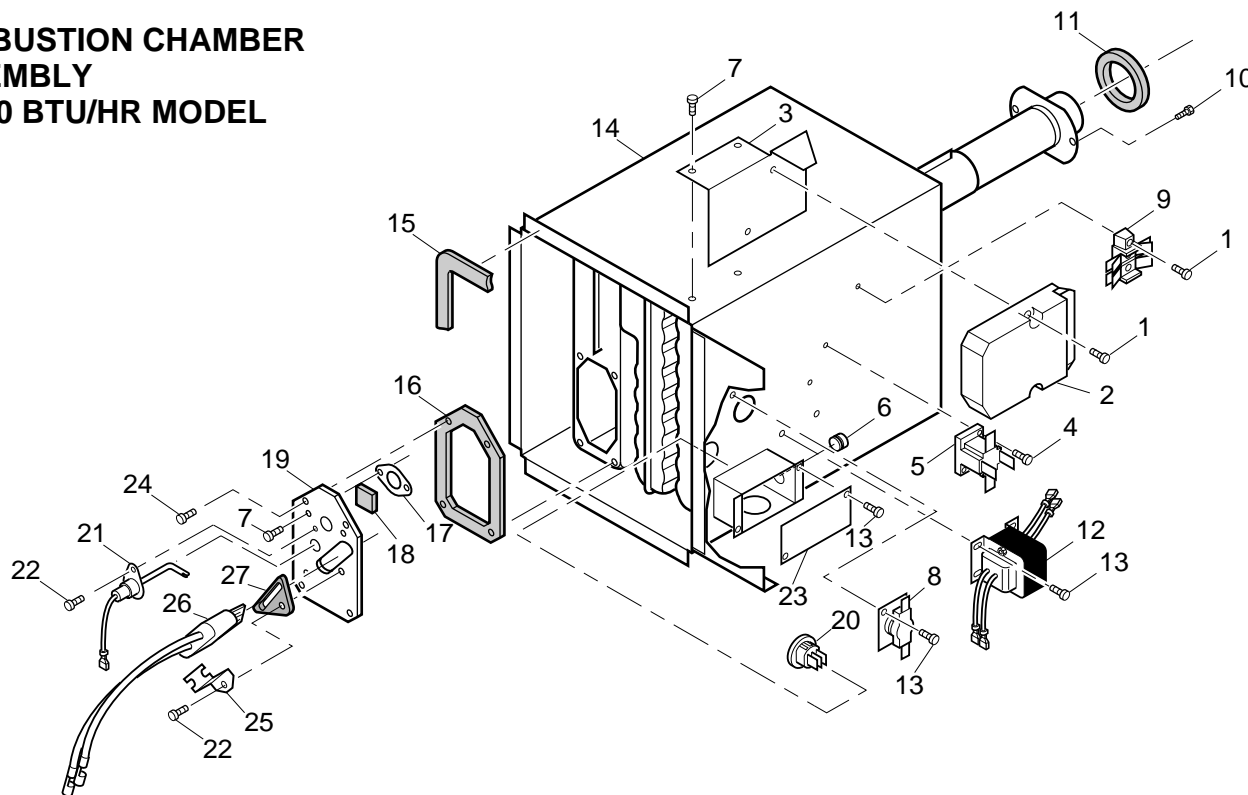

KEY NO.	PART NUMBER	DESCRIPTION	QTY.	KEY NO.	PART NUMBER	DESCRIPTION	QTY.
1	121357	Screw, #6 x 5/8" **	4	14	020983	Combustion Chamber/ Heat Shield Assembly	1
2	231955	Wire Harness and Ignition Control	1	15	070606	Heat Shield Gasket	1
3	062461	Ignition Control Mounting Bracket	1	16	070398	Burner Access Door Gasket	1
4	121372	Screw, #6 x 1/2" **	2	17	290141	Cover Plate	1
5	230625	Time Delay Relay	1	18	310026	Glass Disc	1
6	230218	Bushing	1	19	030893	Burner Access Door	1
7	120158	Screw, #8 x 3/8" **	4	20	230844	Bushing with Terminals	1
8	230825	Limit Switch	1	21	231950	Flame Sensing Probe	1
9	231144	Terminal Block	1	22	121502	Screw, #6 x 3/8" **	2
10	121224	Screw, #10 x 3/4" **	2	23	090211	Junction Box Cover	1
11	070537	Gasket	1	24	121388	Screw, #10 x 1/2" **	4
12	231143	Transformer Assembly	1	25	063018	Glo-Bar Retainer	1
13	121252	Screw, #10 x 3/8" **	6	26	100980-01	Glo-Bar	1
				27	070909	Glo-Bar Gasket	1

\*\* Standard hardware, available at your local hardware store.

# DYNAVENT®

## DIRECT-VENT NATURAL GAS HEATER

### ILLUSTRATED PARTS LIST

This list contains replaceable parts used in your furnace. When ordering parts, follow the instructions listed under *Replacement Parts* on page 19 of this manual.

#### COMBUSTION CHAMBER ASSEMBLY 40,000 BTU/HR MODEL

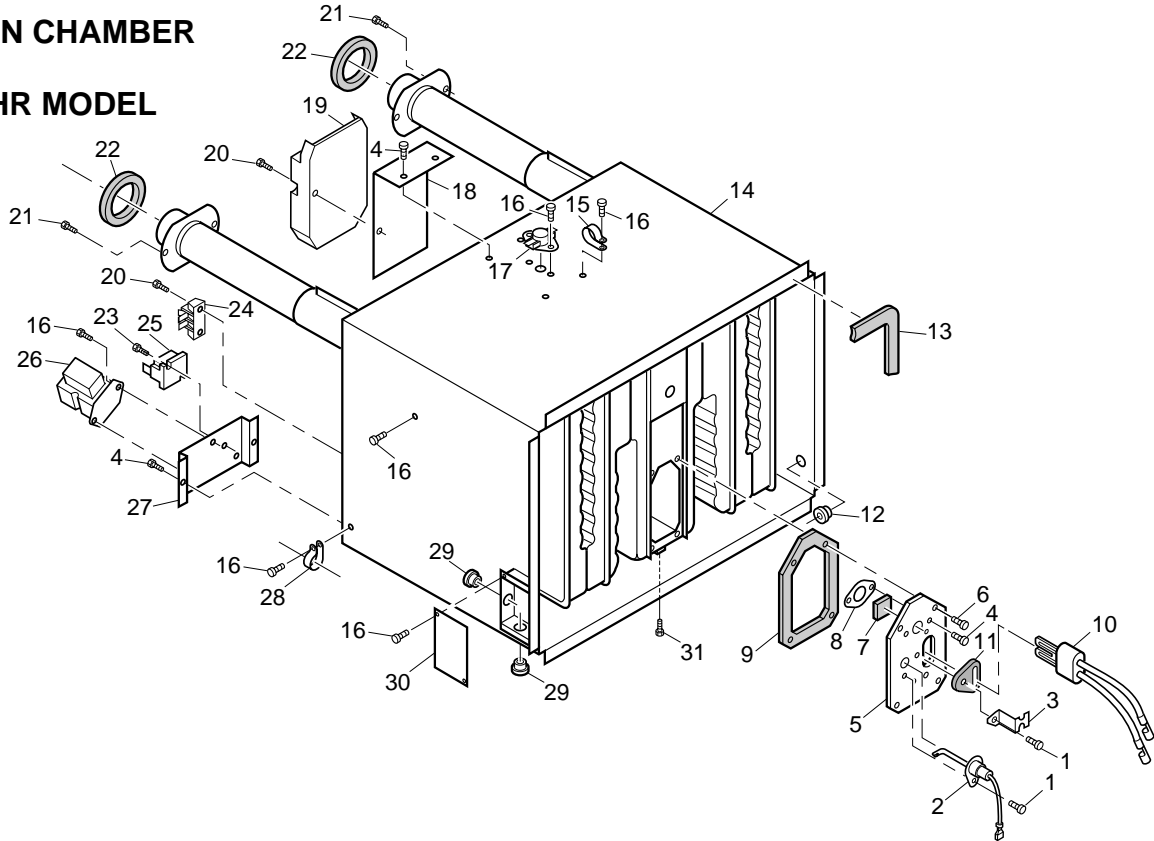

KEY NO.	PART NUMBER	DESCRIPTION	QTY.	KEY NO.	PART NUMBER	DESCRIPTION	QTY.
1	121502	Screw, #6 x 3/8" **	2	18	062563	Ignition Control Mounting Bracket	1
2	231950	Flame Sensing Probe	1	19	231954	Wire Harness and Ignition Control	1
3	063018	Glo-Bar Retainer	1	20	121357	Screw, #6 x 5/8" **	4
4	120158	Screw, #8 x 3/8" **	6	21	121224	Screw, #10 x 3/4" **	4
5	030891	Burner Access Door	1	22	070537	Gasket	2
6	121388	Screw, #10 x 1/2"	4	23	121372	Screw, #6 x 1/2" **	2
7	310026	Glass Disc	1	24	231144	Terminal Block	1
8	290141	Cover Plate	1	25	230625	Time Delay Relay	1
9	070398	Burner Access Door Gasket	1	26	231164	Transformer Assembly	1
10	100980-01	Glo-Bar	1	27	062837	Transformer and Relay Mounting Bracket	1
11	070909	Glo-Bar Gasket	1	28	062694	Wire Clamp, 5/8" Diameter	5
12	230844	Bushing with Terminals	1	29	230555	Strain Relief Bushing	2
13	070607	Heat Shield Gasket	1	30	090211	Junction Box Cover	1
14	020982	Combustion Chamber/Heat Shield Assembly	1	31	121577	Screw, #10 x 1/4" **	2
15	061663	Wire Clamp	2				
16	121252	Screw, #10 x 3/8" **	12				
17	230560	Limit Switch	1				

\*\* Standard hardware, available at your local hardware store.



# OWNER'S MANUAL

## ILLUSTRATED PARTS LIST

This list contains replaceable parts used in your furnace. When ordering parts, follow the instructions listed under *Replacement Parts* on page 19 of this manual.

### BURNER ASSEMBLY 25,000 BTU/HR MODEL

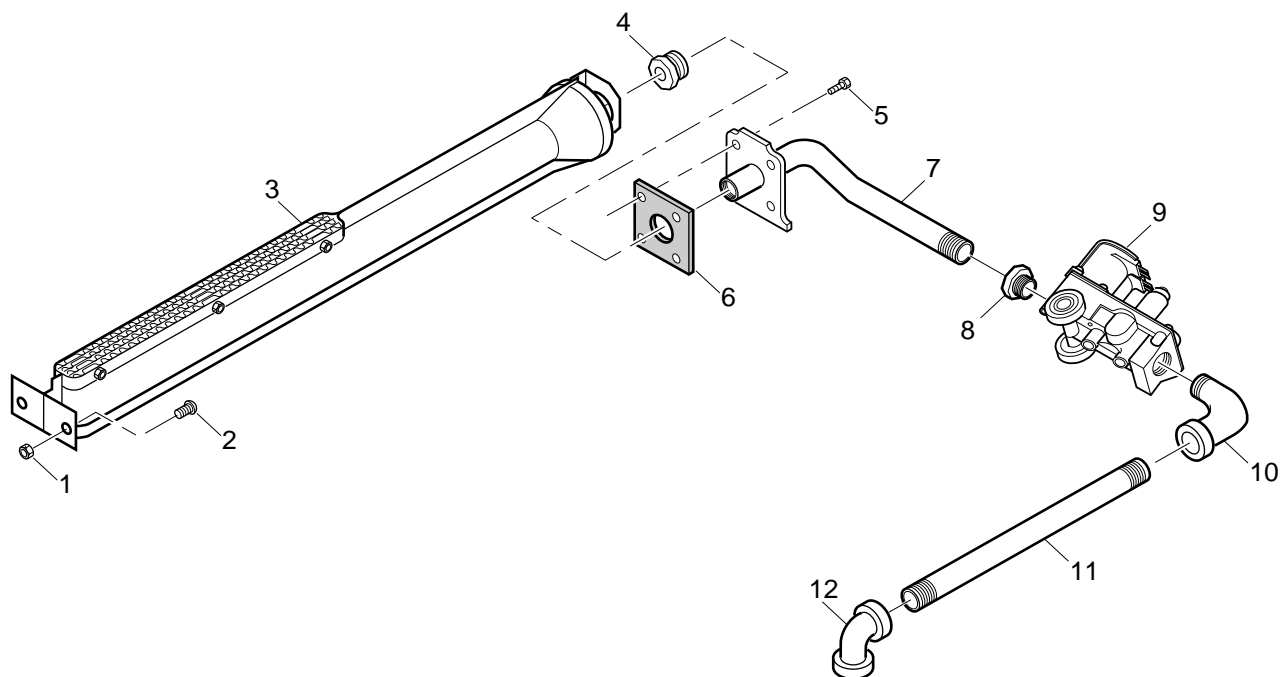

KEY NO.	PART NUMBER	DESCRIPTION	QTY.
1	120717	Hex Nut, #10-24 **	2
2	121459	Screw, #10-24 x 1/2" **	2
3	010701	Burner Assembly	1
4	180220	Main Burner Orifice	1
5	121388	Screw, #10 x 1/2" **	4
6	070408	Manifold Gasket	1
7	171174	Manifold Assembly	1
8	170545	Reducer Fitting, 3/8" NPT to 1/8" NPT **	1
9	160968	Valve	1
10	170012	90° Street Elbow **	1
11	171170	Gas Inlet Pipe	1
12	170082	90° Elbow **	1

\*\* Standard hardware, available at your local hardware store.

# DYNAVENT®

## DIRECT-VENT NATURAL GAS HEATER

### ILLUSTRATED PARTS LIST

This list contains replaceable parts used in your furnace. When ordering parts, follow the instructions listed under *Replacement Parts* on page 19 of this manual.

#### BURNER ASSEMBLY 40,000 BTU/HR MODEL

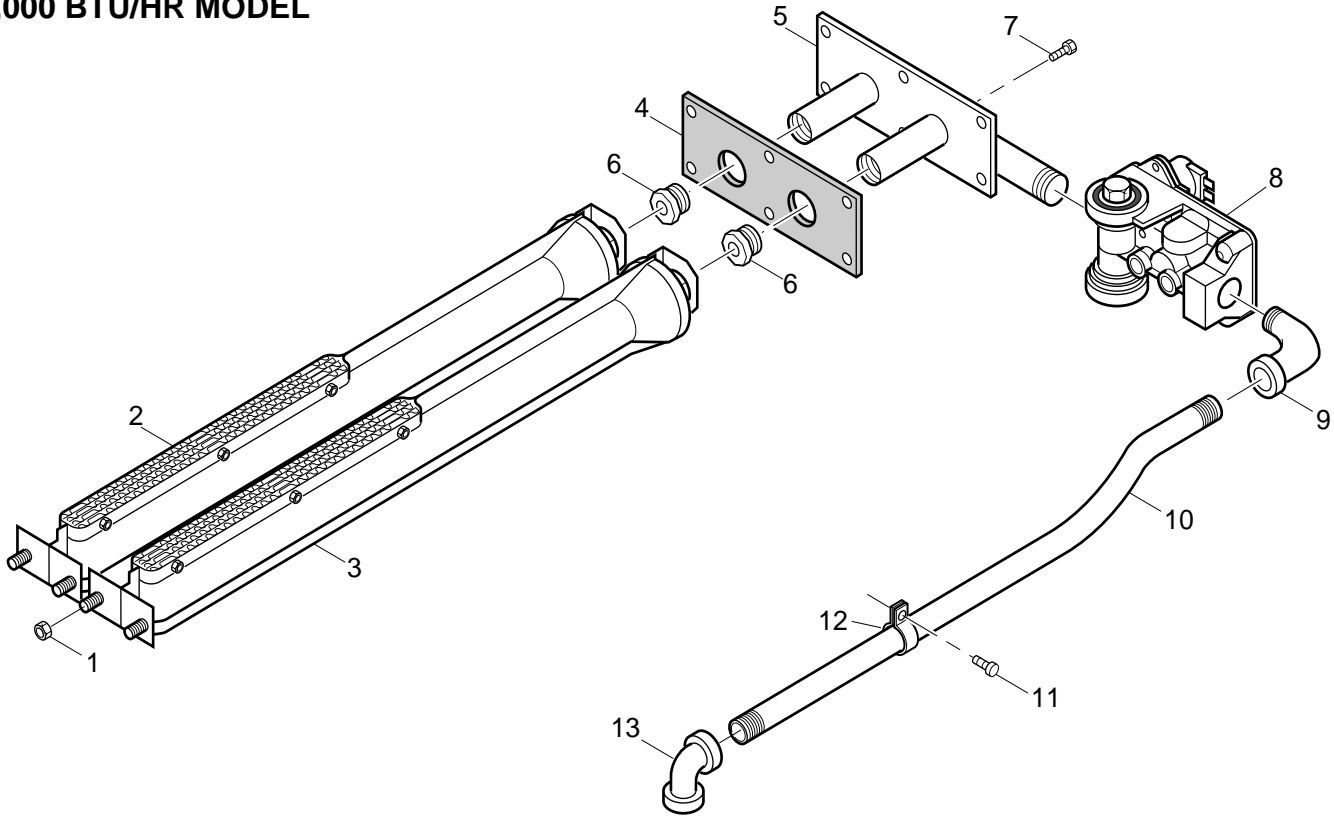

KEY NO.	PART NUMBER	DESCRIPTION	QTY.
1	120717	Hex Nut, #10-24 **	4
2	010621	Left Burner Assembly	1
3	010623	Right Burner Assembly	1
4	070591	Manifold Gasket	1
5	171167	Manifold Assembly	1
6	180189	Main Burner Orifice	2
7	121388	Screw, #10 x 1/2" **	6
8	160968	Valve	1
9	170012	90° Street Elbow **	1
10	171170	Gas Inlet Pipe	1
11	121388	Screw, #10 x 1/2" **	1
12	062694	Gas Inlet Pipe Clamp	1
13	170082	90° Elbow **	1

\*\* Standard hardware, available at your local hardware store.

# OWNER'S MANUAL

## ILLUSTRATED PARTS LIST

### BLOWER ASSEMBLY 25,000 BTU/HR MODEL

This list contains replaceable parts used in your furnace. When ordering parts, follow the instructions listed under *Replacement Parts* on page 19 of this manual.

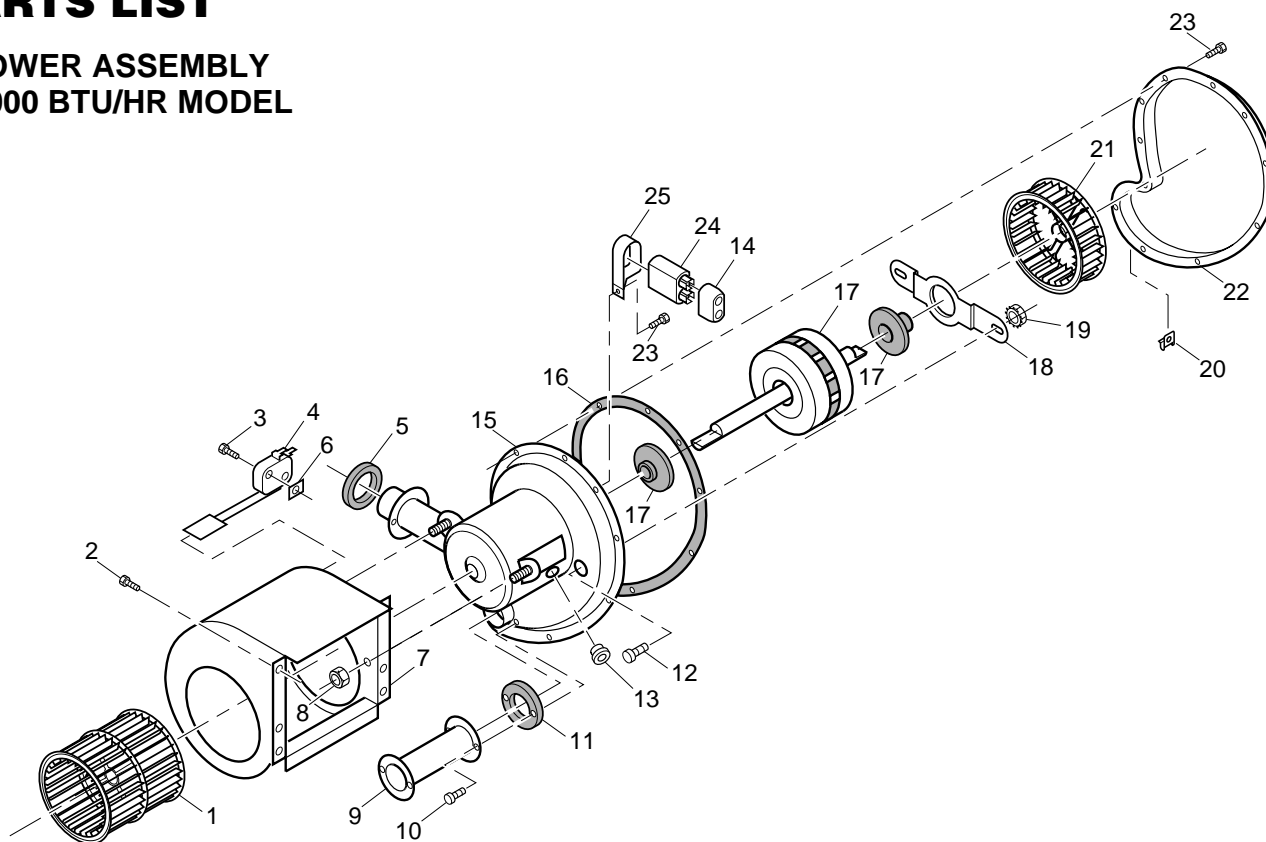

KEY NO.	PART NUMBER	DESCRIPTION	QTY.	KEY NO.	PART NUMBER	DESCRIPTION	QTY.
1	350086	Room Air Wheel	1	16	070386	Combustion Air Housing	
2	121252	Screw, #10 x 3/8" **	5			Gasket	1
3	121247	Screw, #2-56 x 5/8" **	2	17	231389	Motor with Bushings	1
4	230510	Microswitch Assembly	1	18	062307	Motor Support Bracket	1
5	070537	Intake Tube Gasket	1	19	120717	Hex Nut, #10-24 (keps) **	2
6	121661	Tinnerman Nut	2	20	121712	Tinnerman	1
7	390260	Blower Housing (room air)	1	21	350117	Combustion Air Wheel	1
8	121421	Hex Lock Nut, #10-24 **	3	22	390240	Combustion Air Housing (outside)	1
9	050751	Crossover Tube	1	23	120615	Screw, #8 x 1/2" **	10
10	121388	Screw, #10 x 1/2" **	4	24	231036	Capacitor	1
11	070385	Crossover Tube Gasket	2	25	062633	Capacitor Clamp	1
12	121227	Screw, #10-24 x 1/2" **	2	Δ	161093	Equipment Shutoff Valve	1
13	070362	Universal Bushing	1				
14	231231	Capacitor Boot	1				
15	390296	Combustion Air and Motor Cover Assy. Housing	1				

Δ Part available, not shown.

\*\* Standard hardware, available at your local hardware store.

# DYNAVENT®

## DIRECT-VENT NATURAL GAS HEATER

### ILLUSTRATED PARTS LIST

This list contains replaceable parts used in your furnace. When ordering parts, follow the instructions listed under *Replacement Parts* on page 19 of this manual.

#### BLOWER ASSEMBLY 40,000 BTU/HR MODEL

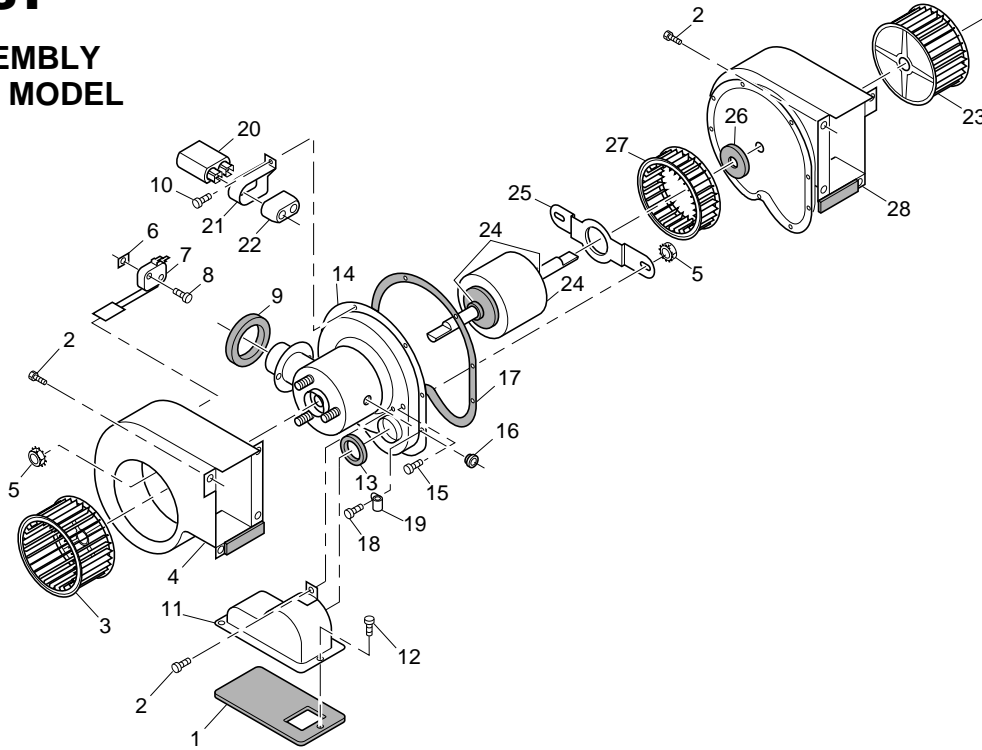

KEY NO.	PART NUMBER	DESCRIPTION	QTY.	KEY NO.	PART NUMBER	DESCRIPTION	QTY.
1	070570	Combustion Air Cover Gasket	1	15	121227	Screw, #10-24 x 1/2" **	2
2	121252	Screw, #10 x 3/8" **	8	16	070362	Universal Bushing	1
3	350088	Room Air Wheel (CW Rotation)	1	17	070406	Combustion Air Housing Gasket	1
4	390328	Room Air Blower Housing (left side)	1	18	120158	Screw, #8 x 3/8" **	10
5	120717	Hex Nut, #10-24 (keps) **	5	19	061663	Wire Clamp	1
6	121661	Tinnerman Nut	2	20	231036	Capacitor	1
7	230681	Microswitch Assembly	1	21	062691	Capacitor Clamp	1
8	121247	Screw, #2-56 x 5/8" **	2	22	231231	Capacitor Boot	1
9	070537	Intake Tube Gasket	1	23	350087	Room Air Wheel (CCW Rotation)	1
10	120615	Screw, #8 x 1/2" **	1	24	231136	Motor with Bushings	1
11	390205	Combustion Air Cover Assy.	1	25	062307	Motor Support Bracket	1
12	121388	Screw, #10 x 1/2" **	3	26	070165	Motor Gasket	1
13	070420	Combustion Air Crossover Gasket	1	27	350085	Combustion Air Wheel	1
14	390318	Combustion Air and Motor Cover Assembly	1	28	390201	Room Air Blower Housing (right side)	1
				Δ	161093	Equipment Shutoff Valve	1

Δ Part available, not shown.

\*\* Standard hardware, available at your local hardware store.



# WARRANTY INFORMATION

KEEP THIS WARRANTY

Model _____
Serial No. _____
Date Purchased _____

Always specify model and serial numbers when communicating with the factory.

We reserve the right to amend these specifications at any time without notice. The only warranty applicable is our standard written warranty. We make no other warranty, expressed or implied.

## LIMITED WARRANTY DYNAVENT GAS WALL FURNACE

DESA International warrants this product to be free from defects in materials and components for one (1) year and five (5) years on the combustion chamber/heat exchanger assembly from the date of first purchase, provided that the product has been properly installed, operated and maintained in accordance with all applicable instructions. To make a claim under this warranty the Bill of Sale or cancelled check must be presented.

This warranty is extended only to the original retail purchaser. This warranty covers only the cost of part(s) required to restore this furnace to proper operating condition. Warranty part(s) MUST be obtained through authorized dealers of this product and/or DESA International who will provide original factory replacement parts. Failure to use original factory replacement parts voids this warranty. The furnace MUST be installed by a qualified installer in accordance with all local codes and instructions furnished with the unit.

This warranty does not apply to parts that are not in original condition because of normal wear and tear, or parts that fail or become damaged as a result of misuse, accidents, lack of proper maintenance or defects caused by improper installation. Travel, diagnostic cost, labor, transportation and any and all such other costs related to repairing a defective furnace will be the responsibility of the owner.

TO THE FULL EXTENT ALLOWED BY THE LAW OF THE JURISDICTION THAT GOVERNS THE SALE OF THE PRODUCT; THIS EXPRESS WARRANTY EXCLUDES ANY AND ALL OTHER EXPRESSED WARRANTIES AND LIMITS THE DURATION OF ANY AND ALL IMPLIED WARRANTIES, INCLUDING WARRANTIES OF MERCHANTABILITY AND FITNESS FOR A PARTICULAR PURPOSE TO ONE (1) YEAR FROM THE DATE OF FIRST PURCHASE; AND DESA INTERNATIONAL'S LIABILITY IS HEREBY LIMITED TO THE PURCHASE PRICE OF THE PRODUCT AND DESA INTERNATIONAL SHALL NOT BE LIABLE FOR ANY OTHER DAMAGES WHATSOEVER INCLUDING INDIRECT, INCIDENTAL OR CONSEQUENTIAL DAMAGES.

Some states do not allow a limitation on how long an implied warranty lasts or an exclusion or limitation of incidental or consequential damages, so the above limitation on implied warranties, or exclusion or limitation on damages may not apply to you.

This warranty gives you specific legal rights, and you may also have other rights that vary from state to state.

For information about this warranty write:

**DESA**  
INTERNATIONAL

2701 Industrial Drive  
P.O. Box 90004  
Bowling Green, KY 42102-9004  
[www.desatech.com](http://www.desatech.com)



NOT A UPC

201835  
Rev. F  
03/00