

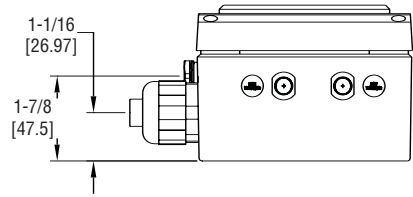

Series DHII Digihelic® II Differential Pressure Controller
Specifications - Installation and Operating Instructions

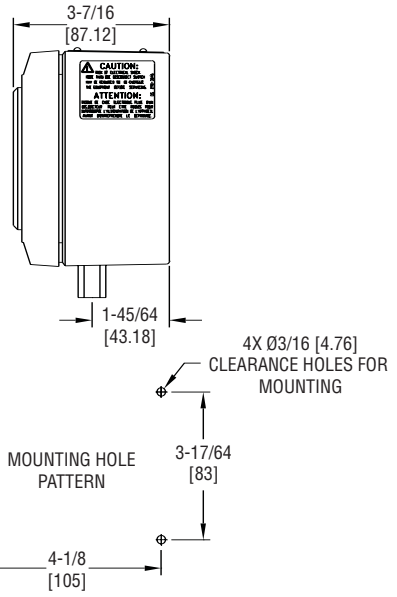

DIMENSIONS

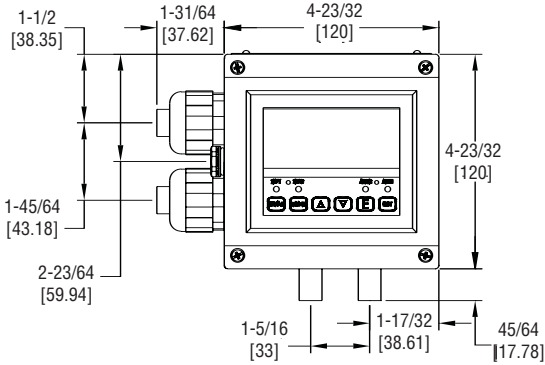

OPTIONAL A-438 BRACKET MOUNTING DIAGRAM

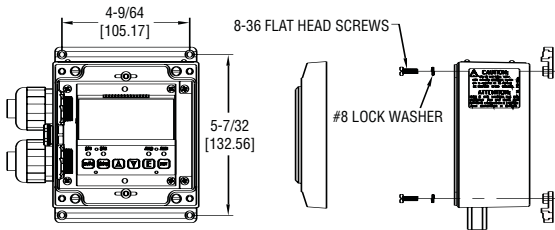

WIRING TERMINAL ACCESS

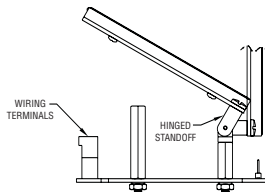
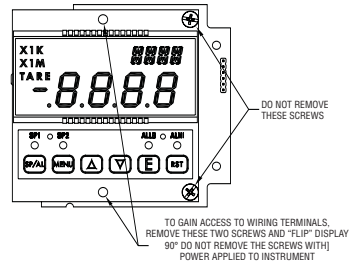

SPECIFICATIONS

Service: Air and non-combustible, compatible gases.

Wetted Materials: Consult factory.

Housing Material: Aluminum, glass.

Accuracy: $\pm 0.5\%$ at 77°F (25°C) including hysteresis and repeatability (after 1 hour warm-up).

Stability: $< \pm 1\%$ per year.

Pressure Limits: Ranges ≤ 2.5 in. w.c. = 2 psi

5": 5 psi; 10": 5 psi; 25": 5 psi; 50": 5 psi; 100": 9 psi.

Temperature Limits: 32 to 140°F (0 to 60°C).

Compensated Temperature Limits: 32 to 140°F (0 to 60°C).

Thermal Effects: 0.020%/°F (0.036/°C) from 77°F (25°C).

Power Requirements:

High Voltage Power = 100 to 240 VAC, 50 to 400 Hz or 132 to 240 VDC.

Low Voltage Power = 24 VDC $\pm 20\%$.

Power Consumption:

Low Voltage Power = 24 VDC - 130 mA max.

High Voltage Power = 100 to 240 VAC, 132 to 240 VDC - 7VA max.

Output Signal: 4-20 mA DC into 900 ohms max.

Zero & Span Adjustments: Accessible via menus.

Response Time: 250 ms (dampening set to 1).

Display: 4 digit backlit LCD 0.6" height. LED indicators for set point and alarm status.

Electrical Connections: Euro type removeable terminal blocks with watertight conduit fittings for 1/2" watertight conduit.

Process Connections: 1/8 female NPT.

Enclosure Rating: Designed to meet NEMA 4 (IP66).

Mounting Orientation: Mount unit in horizontal plane.

Size: 4.73" x 4.73" x 3.43" (120 mm x 120 mm x 87.1 mm).

Weight: 2 lb 10 oz (1.19 kg).

Serial Communications: Modbus® RTU, RS485, 9600 Baud.

Agency Approvals: UL & CE.

SWITCH SPECIFICATIONS

Switch Type: 2 SPDT relays.

Electrical Rating: 8 Amps at 240 VAC resistive.

Set Point Adjustment: Adjustable via keypad on face.

Modbus® is a registered trademark of Schneider Automation.

WIRING

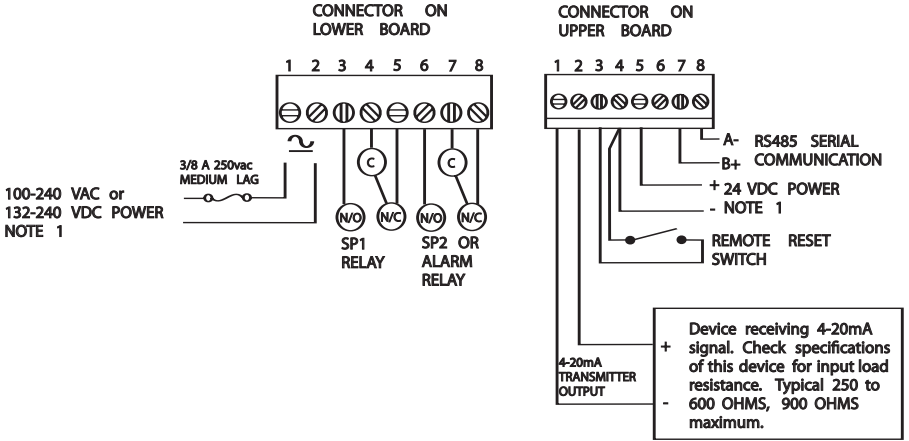

WARNING

If Digihelic® II Controller is powered by 24 VDC, the device receiving the 4-20 mA transmitter output **MUST NOT** share a common ground with the 24 VDC supply or damage to the Digihelic® II Controller will result.

NOTES:

1. The instrument may be powered from the AC line or 24 VDC. Do not wire AC line terminals 1-2 on the lower board and 24 VDC terminals 4-5 on the upper board at the same time or damage to the unit will result.
2. For supply connections, wire in accordance with an equivalent national standard or code. Use copper conductors only rated for at least 75°C.
3. Terminals on upper board are rated CLASS 2.
4. **ISOLATION:**
 - Relays - 1500 VAC to all other inputs and outputs.
 - AC Line Power (terminals 4-5) - 1500 VAC to all other inputs and outputs.
 - RS485 output - 500 VAC to all other CLASS 2 wiring.
 - The 24 VDC Power, 4-20 mA transmitter, and Remote Reset Switch share a common ground.
5. The Remote Reset Switch must be a dry contact switch.
6. Shielded cable is required for RS485 wiring.



When wiring the instrument, you must follow industry standard practice for control and protection against Electro-Static Discharge (ESD). Failure to exercise good ESD practices may cause damage to the control.

WIRING

1. Remove cover.
2. To gain access to the wiring terminal blocks, remove the upper and lower screws toward the center of the display board, and then flip the display board up at a 90° angle.
3. Wire to the two terminals blocks as shown in the wiring diagram.

NOTE: Depending on the application, it may be only necessary to wire to the smaller terminal block on the upper board. In that case one of the liquid tight fittings may be removed and replaced with the provided rubber plug.

4. For liquid tight applications, use only 1/2" liquid tight conduit.
5. When wiring is complete, reverse steps 2 and 1. Make sure the cover is properly tightened to the housing.

DIGIHELIC® II CONTROLLER RS485 WIRING

DIGIHELIC - RS485 WIRING TO DAISY CHAIN INSTRUMENTS ON THE RS485 BUSS
UP TO 128 UNITS MAY BE DAISY CHAINED

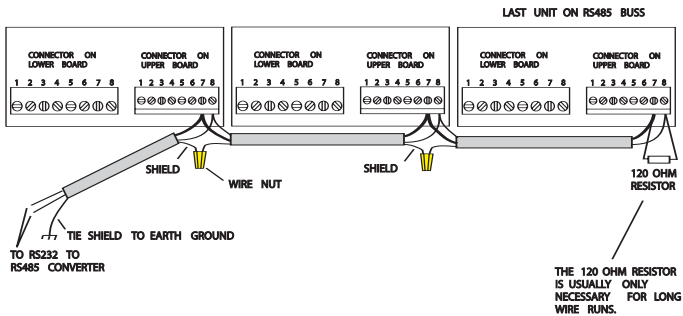

INSTALLATION

Mount the instrument in a location that will not be subject to excessive temperature, shock or vibration.

Pressure Connections





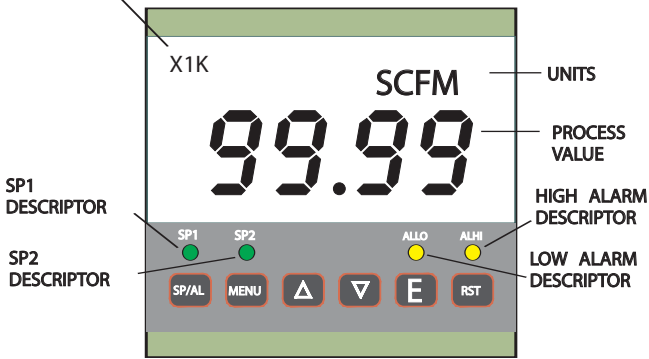

Use 1/8 male NPT fittings. When tightening fittings, grasp the brass fitting on the Digihelic® II Controller with a 1/2" wrench to prevent the fitting on the Digihelic® II Controller from turning.

MULTIPLIER DESCRIPTOR
VISIBLE WITH SOME VELOCITY
AND FLOW RANGES

FRONT PANEL



KEY FUNCTIONS

	HOME POSITION FUNCTION	MAIN MENU FUNCTION	SUB MENU FUNCTION
 SP/AL	Sequences the display through SET POINT and ALARM settings	Return to home position	Return to home position
 MENU	Allows access to the menus	Return to home position	Return to previous menu
 UP ARROW		Sequences through menus	Increments a value
 DOWN ARROW		Sequences through menus	Decrements a value
 ENTER	Displays full scale range of unit	Enter into SUB MENU	Changes a value or setting. Press ENTER and display will blink. Adjust with UP or DOWN arrows. Press ENTER to store. Display will stop blinking.
 RESET	Clears or resets an Alarm (alarm set for manual reset)		Peak/Valley SUB MENU resets display to present value.

SETTING SET POINTS AND ALARMS

The **SP/AL** hot key provides direct access to the Set Point and Alarm MENU. The Set Point and Alarm MENUS that are displayed are based upon the Control (Ctrl) SUB MENU.

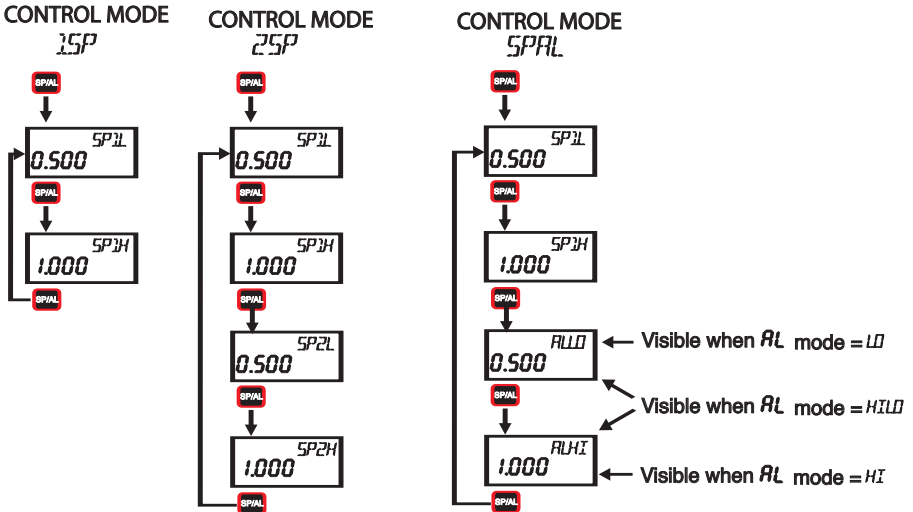

SET POINT ADJUSTMENT

Adjusting the Digihelic® II Controller Set Points is quick and simple. Instead of setting a set point and deadband, simply adjust *SP1H* or *SP2H* for the desired relay turn on point, and then adjust *SP1L* or *SP2L* for the desired relay turn off point.

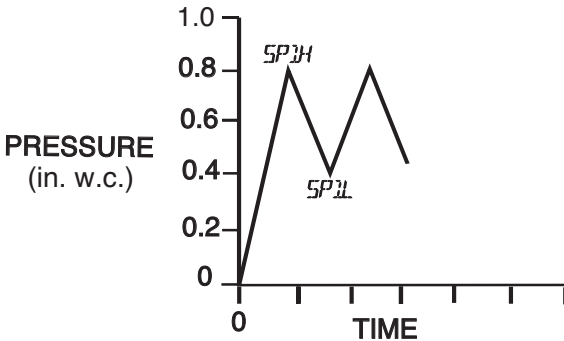

In the above graph, an instrument with a 1.0" range would have the SP1 relay turn on at 0.8" and off at 0.4". *SP1H* sets the relay turn on point, and *SP1L* sets the relay turn off point. The relays outputs normally function in the direct acting mode, which means the relays turn on with an increase in pressure. SP1 may be configured to act as a reverse acting relay (refer to the 1SP SUB MENU setting, page 15). When set for reverse acting, *SP1H* sets the relay turn OFF point, and *SP1L* sets the relay turn ON point. SP2 is always direct acting.

MENU MAP

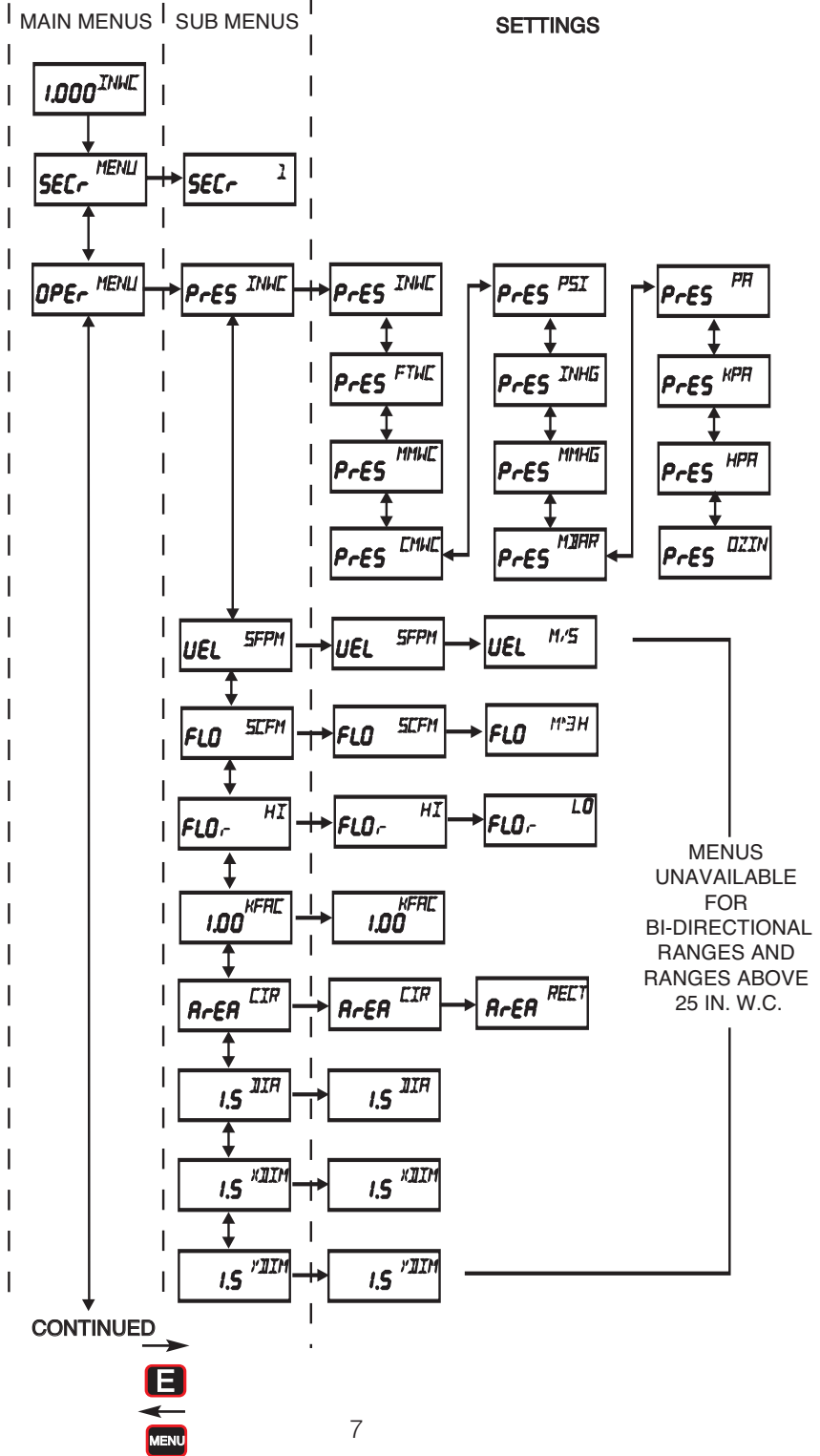

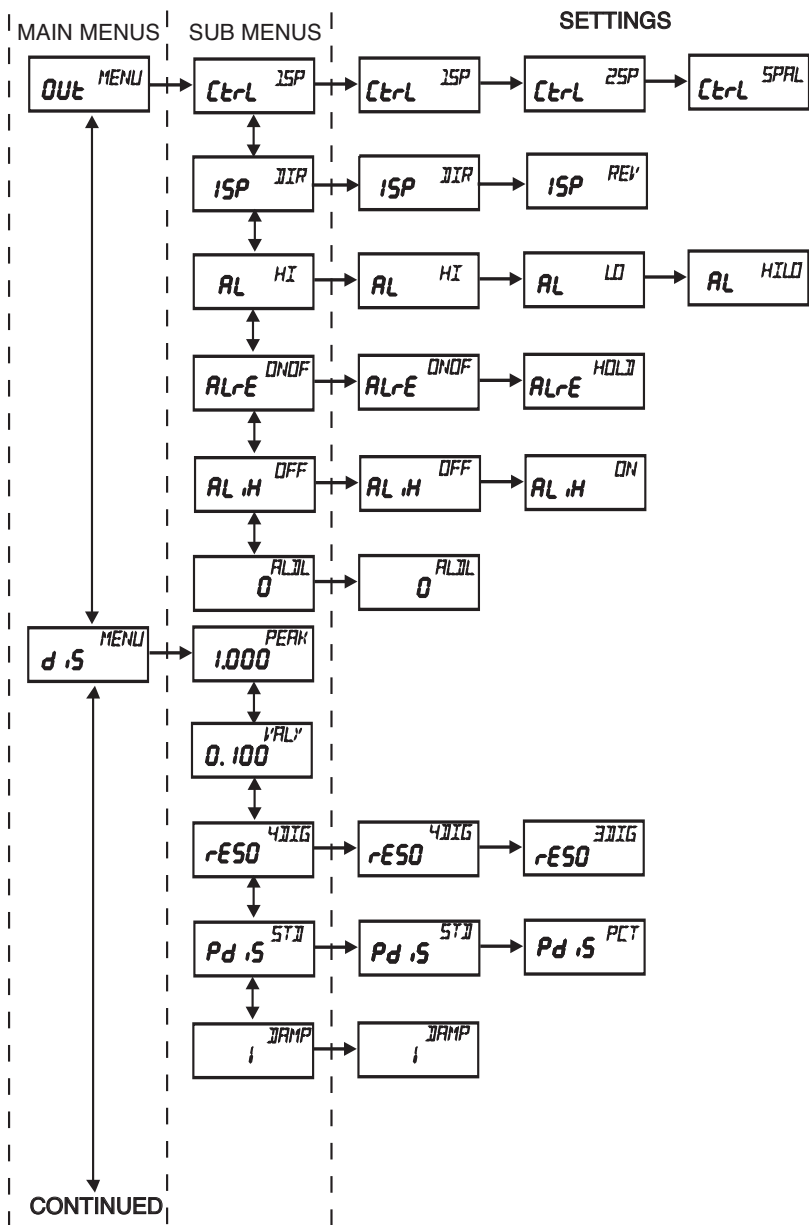

MAIN MENU

SUB MENU

SETTINGS

AdU ^{MENU}

0 ^{PDL}

0 ^{PDL}

Menus present only
in pressure operation

1000 ^{PDLH}

1000 ^{PDLH}

0.250 ^{MSP1}

0.250 ^{MSP1}

3.250 ^{MSP2}

3.250 ^{MSP2}

32 ^{ADJDR}

32 ^{ADJDR}

d.S ^{WR}

d.S ^{WR}

En ^{WR}

CAL ^{ZERO}

CAL ^{ZERO}

CAL ^{SPAN}

CAL ^{SPAN}



Main Menu Selections (Upper Right Display Reads MENU)

SEC Security - Lock out access to Set Point and Alarm settings, or lock out access to all settings.

OPER Operation - Selection of Pressure, Velocity or Flow and corresponding engineering units.

OUT Output - Select a Single Set Point, 2 Set Points, or a Set Point and an Alarm mode of operation.

d.S Display - Monitor and adjust display related settings: Peak, Valley, display resolution, % output and dampening.

Adv Advanced functions - Modify advanced function parameters, transmitter output scaling, Modbus® communication settings, Maintenance Set Point settings and calibration.

MAIN MENUS and SUB MENUS

SEC_r (Security) MAIN MENU

SEC_r is the only SUB MENU in the security MENU. When the security SUB MENU is selected, the present security level is displayed in the upper right hand display. To change the security level, adjust the number displayed to the number shown in the following table for the desired security level.

Security Level Displayed	Access	Password Value to Enter
1	All menus access	10
2	Menu Access SP/AL Locked	70
3	SP/AL Access Menus Locked	90
4	All settings locked	111

The password values shown in the table cannot be altered, so retain a copy of these pages for future reference.

OPE_r (Operation) MAIN MENU

The *OPE_r* MENU selects the measurement type of the instrument. The SUB MENUS are:

PRES - Pressure

KFAC - K Factor

XDIM - X Dimension

VEL - Velocity

AREA - Area

YDIM - Y Dimension

FLO - Flow

DIA - Diameter

If the instrument is set for Velocity, the *OPE_r* MENU will have an additional *KFAC* SUB MENU. If the instrument is set for Flow, the *OPE_r* MENU will have additional *KFAC* and *AREA* SUB MENUS. These will be discussed under Velocity and Flow. When scrolling through the *OPE_r* SUB MENU, the measurement type the unit is currently set for will show the units in the upper right display. The other measurement types will have a blank upper right display.



PrES (Pressure) SUB MENU

For pressure measurement, the following units are available:

INWC - Inches of water column

MMHG - Millimeters of mercury

FTWC - Feet of water column

MBAR - Millibar

MMWC - Millimeters of water column

PA - Pascal

CMWC - Centimeters of water column

KPA - Kilopascals

PSI - Pounds per square inch

HPA - Hectopascals

INHG - Inches of mercury

OZIN - Ounce inches

Table 1 Pressure Range vs. Available Units

INWC	FTWC	MMWC	CMWC	PSI	INHG	MMHG	MBAR	PA	KPA	HPA	OZIN
.1000		2.540	.2540			.1868	.2491	24.91		.2491	
.2500		6.350	.6350			.4671	.6227	62.27		.6227	.1445
.5000		12.70	1.270			.9342	1.245	124.5	.1245	1.245	.2890
1.000		25.40	2.540			1.868	2.491	249.1	.2491	2.491	.5780
2.500	.2083	63.50	6.350		.1839	4.671	6.227	622.7	.6227	6.227	1.445
5.000	.4167	127.0	12.70	.1806	.3678	9.342	12.45	1245	1.245	12.45	2.890
10.00	.8333	254.0	25.40	.3613	.7356	18.68	24.91	2491	2.491	24.91	5.780
25.00	2.083	635.0	63.50	.9032	1.839	46.71	62.27	6227	6.227	62.27	14.45
50.00	4.167	1270	127.0	1.806	3.678	93.42	124.5		12.45	124.5	28.90
100.0	8.333	2540	254.0	3.613	7.356	186.8	249.1		24.91	249.1	57.80

NOTE: *OVFL* (over flow) or *UNFL* (under flow) will appear when the ranges have been exceeded above or below full scale by 2%.

VEL (Velocity) SUB MENU

For velocity measurement, the following units are available:

SFPM - Standard feet per minute

M/S - Meters per second

Table 2 Available Velocity Ranges

INPUT RANGE INWC	SFPM RANGE	M/S RANGE
0 - 0.1	0 - 1266	0 - 6.431
0 - 0.25	0 - 2002	0 - 10.17
0 - 0.5	0 - 2832	0 - 14.39
0 - 1	0 - 4004	0 - 20.35
0 - 2.5	0 - 6332	0 - 32.17
0 - 5	0 - 8954	0 - 45.48
0 - 10	0 - 12.66 x IK	0 - 64.33
0 - 25	0 - 20.02 x IK	0 - 101.7

NOTE: Air velocity and flow readings are based upon standard dry air conditions with an ambient temperature of 70°F and a barometric pressure of 29.92 INHG.

FLO (Flow) SUB MENU

For flow measurements the following units are available:

SCFM - Standard cubic feet per minute

M³H - Cubic meters per hour

FLO_r (Flow Range) SUB MENU

LO - 99.99 x 1K flow range

HI - 999.9 x 1K flow range

Tables 3 -6 show the flow ranges available, and the maximum duct size that can be set for each input range.

Table 3

FLO_r = LO Maximum Duct Size (English)

RANGE IN WC	SCFM RANGE	MAX. DUCT SIZE, SQ. FT.
0.1	99.99 x 1K	78.9
0.25	99.99 x 1K	49.9
0.5	99.99 x 1K	35.3
1	99.99 x 1K	24.9
2.5	99.99 x 1K	15.7
5	99.99 x 1K	11.1
10	99.99 x 1K	7.8
25	99.99 x 1K	4.9

Table 4

FLO_r = HI Maximum Duct Size (English)

RANGE IN WC	SCFM RANGE	MAX. DUCT SIZE, SQ. FT.
0.1	999.9 x 1K	789.8
0.25	999.9 x 1K	499.5
0.5	999.9 x 1K	353.1
1	999.9 x 1K	249.7
2.5	999.9 x 1K	157.9
5	999.9 x 1K	111.7
10	999.9 x 1K	78.9
25	999.9 x 1K	49.9

Table 5

FLO_r = LO Maximum Duct Size (Metric)

RANGE IN WC	M ³ /Hr RANGE	MAX. DUCT SIZE M ²
0.1	99.99 x 1K	4.32
0.25	99.99 x 1K	2.73
0.5	99.99 x 1K	1.93
1	99.99 x 1K	1.37
2.5	99.99 x 1K	0.86
5	99.99 x 1K	0.61
10	99.99 x 1K	0.43
25	99.99 x 1K	0.27

Table 6

FLO_r = HI Maximum Duct Size (Metric)

RANGE IN WC	M ³ /Hr Range	MAX. DUCT SIZE, M ²
0.1	999.9 x 1K	43.19
0.25	999.9 x 1K	27.31
0.5	999.9 x 1K	19.3
1	999.9 x 1K	13.64
2.5	999.9 x 1K	8.63
5	999.9 x 1K	6.10
10	999.9 x 1K	4.31
25	999.9 x 1K	2.73

KFAC SUB MENU

KFAC K Factor - becomes accessible if the instrument is set for Velocity or Flow. When the Digihelic® II Controller is used with a pitot tube, the manufacturer may specify a K Factor. The adjustment range is 0.01 to 2.00. The factory setting is 1.

AREA, DIA, XDIM and YDIM SUB MENUS

These SUB MENUS become accessible if the instrument is set for flow. When measuring flow, the area of the duct must be specified. Tables 3 and 4 show the input range vs maximum flow and duct size. For a rectangular duct the maximum size is specified in square feet or meters. For a circular duct the maximum size is specified as the diameter. X, Y and circular dimensions are entered in feet with 0.01 foot resolution for $FLOr = LO$ and 0.1 foot resolution for $FLOr = HI$, or entered in millimeters with 1 millimeter resolution.

AREA - Area, select *CIR* for a circular duct or *RECT* for a rectangular duct. If a circular duct is selected, the *DIA* SUB MENU will be activated. If a rectangular duct is selected, the *XDIM* and *YDIM* SUB MENUS will be activated.

DIA - Diameter, enter the diameter of a duct

XDIM - Enter the "X" dimension of a duct

YDIM - Enter the "Y" dimension of a duct

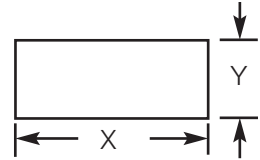

OUT (Output) MAIN MENU

The *OUT* MENU selects the output type of the instrument. The SUB MENUS are:

CTRL - Control type

ISP - SP1 reverse or direct acting

AL - Alarm type

ALRE - Alarm reset, manual or auto

ALIH - Alarm inhibit

ALDL - Alarm delay

Ctrl (Control) SUB MENU

1SP - Single set point

2SP - Two fully independent set points

SPAL - Single set point and alarm

1SP (SP1 Reverse or Direct Acting) SUB MENU

DIR - Direct. Relay turns on with increasing pressure

REV - Reverse. Relay turns on with decreasing pressure

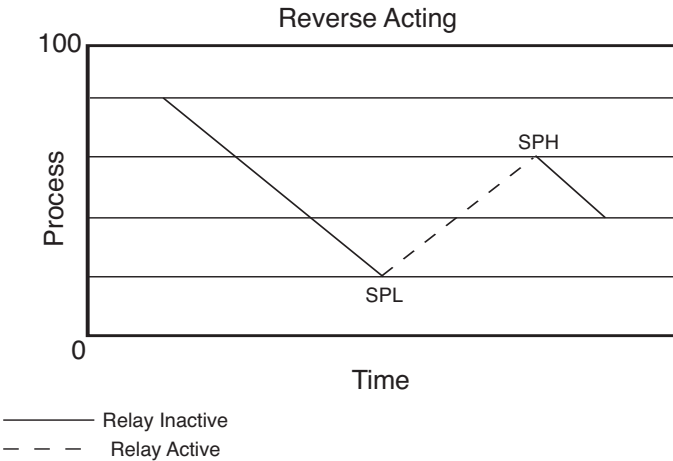
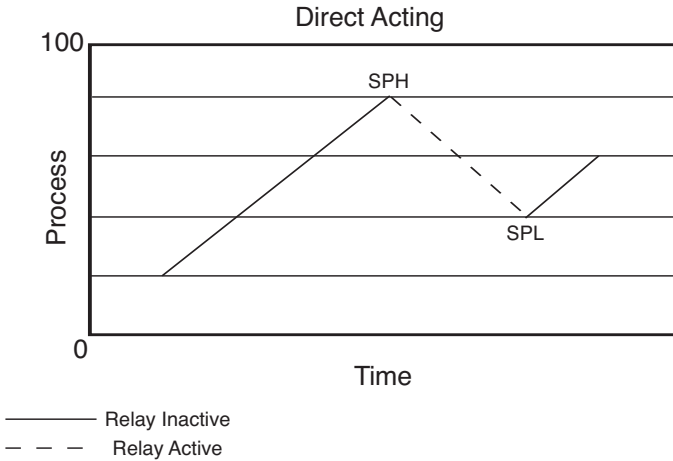

The following alarm function SUB MENUS are activated when *Ctrl* is set to *SPAL*:

AL (Alarm Type) SUB MENU

HI - High alarm

LO - Low alarm

HILLO - For a high/low guardband type alarm

ALARM ADJUSTMENT

Alarm settings are dependent upon the selected alarm mode. The Digihelic® II Controller alarm may be configured as a High Alarm, Low Alarm, or High/Low Alarm. Alarm settings are all absolute and may be set to anywhere within the range of the instrument. The dead bands of the alarms are fixed at 1% of full scale.

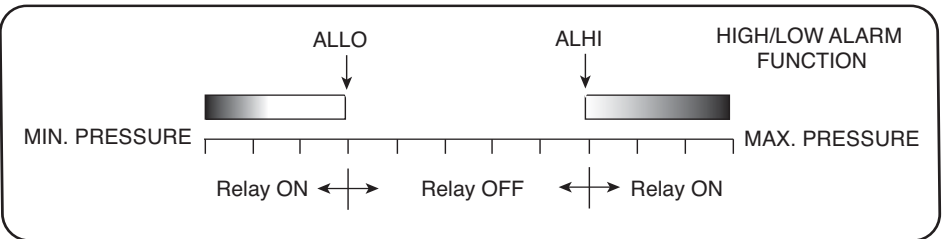
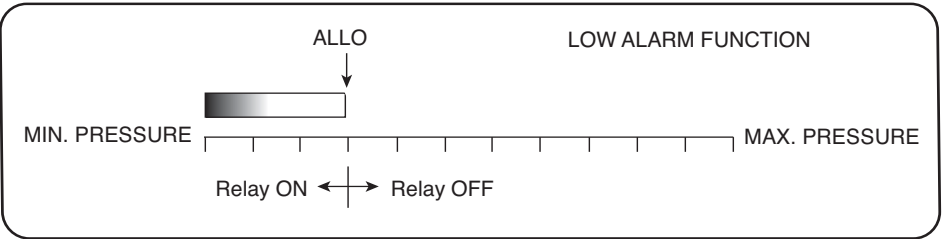
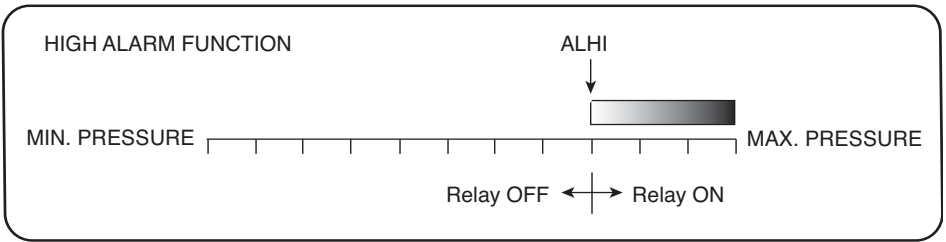

ALRE (Alarm Reset) SUB MENU

ON/OFF - Automatic reset

HOLD - Manual reset. An alarm is reset by the RESET key on the front panel, or an external reset switch.

ALH (Low Alarm Inhibit) SUB MENU

ON - Alarm inhibit is on

OFF - Alarm inhibit is off

If *ALH* is selected ON, a low alarm condition is suspended upon power up until the process value passes through the alarm set point once.

ALDL (Alarm Delay) SUB MENU

Sets the amount of time an alarm condition must be continuously met before the alarm condition is recognized. The alarm delay is adjustable from 0-3600 seconds.

d.S (Display) MAIN MENU

PEAK - Peak value

VAL₄ - Valley value

ZERO - Zero

r-ESD - Resolution

Pd.S - Process display

DAMP - Dampening level

PEAK (Peak) SUB MENU

The Peak feature stores the highest pressure reading the instrument has measured since the last reset or power up. At power up *PEAK* is reset to the present pressure reading. To manually reset the *PEAK* value, press the RESET key while in the *PEAK* SUB MENU.

VAL₄ (Valley) SUB MENU

The valley feature stores the lowest pressure reading the instrument has measured since the last reset or power up. At power up *VAL₄* is reset to the present pressure reading. To manually reset the *VAL₄* value, press the RESET key while in the *VAL₄* SUB MENU.

rESD (Resolution) SUB MENU

The Digihelic® II Controller is capable of displaying four digits of resolution. However, at very low pressures the instability of the pressure may cause fluctuations in the least significant digit causing the least significant digit to be of little value.

Three digit resolution (*3DIG*) can only be active when there is at least one digit to the right of a decimal.

3DIG - Set display for 3 digit resolution

4DIG - Set display for 4 digit resolution

Pd.S (Process Display) SUB MENU

STD - Display reads pressure, velocity, or flow values

PCT - Display reads % of full scale value

When the display is reading percent, *PCT* is displayed in the upper right of the display. The percent display is only available in pressure operation.

DAMP (Dampening) SUB MENU

Adjust from 1-16

Dampening stabilizes the display from instabilities due to things such as vibration and excessive pressure fluctuations. The dampening setting adjusts the amount of readings that are averaged for each display update. Adjust the dampening value until the display reads a stable value for the application.

Adv (Advanced) MAIN MENU

POL - Process output low

ADDR - Modbus® address

POH - Process output high

WR - Modbus® write enable/disable

MSPI - Maintenance set point 1

ZERO - Zero calibration

MSPI2 - Maintenance set point 2

SPAN - Span calibration

POL and POH (Process Output Low and High) SUB MENUS

This feature is used in pressure operation only.

Process output low and high are used to scale the 4-20 mA output. Set *POL* to the desired display reading for 4mA output, and set *POH* to the desired display reading for 20 mA output. *POH* must be higher than *POL*. *POL* may be adjusted 2% BELOW minimum scale up to *POH*. *POH* may be adjusted from *POL* to 2% ABOVE maximum scale.

MSP1 and MSP2 (Maintenance Set Point 1 & 2) SUB MENUS

Adjust for the desired maintenance set points when the unit is placed in the maintenance mode. The deadband is fixed at 2% of full scale. To enter or leave the maintenance mode, press and hold the  for 8 seconds.

ADDR (Modbus® Address) SUB MENU

Modbus® communication instrument address. Set from 1 to 247. This number must match the address number used by the host computer.

To obtain the Digihelic® II Controller Modbus® register list please visit www.dwyer-inst.com

See page 4 for wiring diagram.

WR (Modbus® Write Protect) SUB MENU

dS - Disables write commands from Modbus®. Modbus® can only read information from the instrument.

Er - Enable write commands from Modbus®. Modbus® can read information from and write information to the instrument.

ZERO and SPAN (Calibration of Zero and Span) SUB MENUS

The lower display reads *CAL* in this mode.

ZERO Calibration

NOTE: For accurate calibration, DO NOT apply any pressure when performing this function.

With the display reading *ZERO*, press the ENTER key. The upper display will blink. Press ENTER again to complete the zeroing of the instrument or press the *MENU* key to cancel.

SPAN Calibration

With the display set to *SPAN*, apply full scale pressure to the unit. Press the ENTER key. The upper display will blink. Press ENTER again to complete the calibration or press the *MENU* key to cancel.