

# Comfort Glow®

## ROYAL ENGLISH OAK, BILTMORE SPLIT OAK, AND WINCHESTER OAK UNVENTED (VENT-FREE) NATURAL GAS LOG HEATER

VARIABLE MANUALLY-CONTROLLED MODELS ALSO DESIGN-CERTIFIED

AS VENTED DECORATIVE APPLIANCES

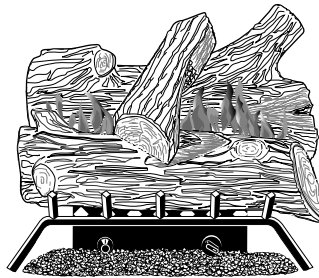
### OWNER'S OPERATION AND INSTALLATION MANUAL

18" and 24" Variable  
Manually-Controlled Models

**CGS2718N**

**CGS3124N**

**CLD3018N**



(Winchester Oak Model Shown)

24" and 30" Thermostatically-  
Controlled Models

**CLD3924NT**

**CCL3930NT(A)**



Patent  
Pending

**WARNING:** If the information in this manual is not followed exactly, a fire or explosion may result causing property damage, personal injury, or loss of life.

- Do not store or use gasoline or other flammable vapors and liquids in the vicinity of this or any other appliance.
- **WHAT TO DO IF YOU SMELL GAS**
  - Do not try to light any appliance.
  - Do not touch any electrical switch; do not use any phone in your building.
  - Immediately call your gas supplier from a neighbor's phone. Follow the gas supplier's instructions.
  - If you cannot reach your gas supplier, call the fire department.
- Installation and service must be performed by a qualified installer, service agency, or the gas supplier.

**WARNING:** Improper installation, adjustment, alteration, service, or maintenance can cause injury or property damage. Refer to this manual for correct installation and operational procedures. For assistance or additional information consult a qualified installer, service agency, or the gas supplier.

**WARNING:** This appliance is for installation only in a solid-fuel burning masonry or UL127 factory-built fireplace, or in an approved ventless firebox. It is design-certified for these installations in accordance with ANS Z21.11.2.

**Exception:** Do not install this appliance in a factory-built fireplace that includes instructions stating it has not been tested or should not be used with unvented gas logs.

**WARNING:** This is an unvented gas-fired heater. It uses air (oxygen) from the room in which it is installed. Provisions for adequate combustion and ventilation air must be provided. Refer to *Air for Combustion and Ventilation* section on page 4 of this manual.

This appliance may be installed in an aftermarket\* manufactured (mobile) home, where not prohibited by state or local codes.

\* Aftermarket: Completion of sale, not for purpose of resale, from the manufacturer

Save this manual for future reference.

**UNVENTED NATURAL GAS LOG HEATER**

**SAFETY  
INFORMATION**

**⚠ WARNINGS**

**IMPORTANT: Read this owner's manual carefully and completely before trying to assemble, operate, or service this heater. Improper use of this heater can cause serious injury or death from burns, fire, explosion, electrical shock, and carbon monoxide poisoning.**

**⚠ DANGER: Carbon monoxide poisoning may lead to death!**

**Carbon Monoxide Poisoning:** Early signs of carbon monoxide poisoning resemble the flu, with headaches, dizziness, or nausea. If you have these signs, the heater may not be working properly. **Get fresh air at once!** Have heater serviced. Some people are more affected by carbon monoxide than others. These include pregnant women, people with heart or lung disease or anemia, those under the influence of alcohol, and those at high altitudes.

**Natural Gas:** Natural gas is odorless. An odor-making agent is added to the gas. The odor helps you detect a gas leak. However, the odor added to the gas can fade. Gas may be present even though no odor exists.

Make certain you read and understand all Warnings. Keep this manual for reference. It is your guide to safe and proper operation of this heater.

**⚠ WARNING: Any change to this heater or its controls can be dangerous.**

1. This appliance is only for use with the type of gas indicated on the rating plate. This appliance is not convertible for use with other gases.
2. If you smell gas
  - shut off gas supply
  - do not try to light any appliance
  - do not touch any electrical switch; do not use any phone in your building
  - immediately call your gas supplier from a neighbor's phone. Follow the gas supplier's instructions
  - if you cannot reach your gas supplier, call the fire department
3. This heater shall not be installed in a bedroom or bathroom unless installed as a vented appliance (Variable Manually-Controlled Models Only) (see *Installing Damper Clamp Accessory for Vented Operation*, page 10).
4. Never install the heater
  - in a recreational vehicle
  - where curtains, furniture, clothing, or other flammable objects are less than 42 inches from the front, top, or sides of the heater
  - in high traffic areas
  - in windy or drafty areas
5. Before installing in a solid fuel burning fireplace, the chimney flue and firebox must be cleaned of soot, creosote, ashes and loose paint by a qualified chimney cleaner. Creosote will ignite if highly heated. Inspect chimney flue for damage. If damaged, operate heater with flue damper closed.
6. If fireplace has glass doors, never operate this heater with glass doors closed. If you operate heater with doors closed, heat buildup inside fireplace will cause glass to burst. Also if fireplace opening has vents at the bottom, you must open the vents before operating heater.
7. You must operate this heater with a fireplace screen in place. Make sure fireplace screen is closed before running heater.
8. This log heater is designed to be smokeless. If logs ever appear to smoke, turn off heater and call a qualified service person. **Note:** During initial operation, slight smoking could occur due to log curing and heater burning manufacturing residues.
9. To prevent the creation of soot, follow the instructions in *Cleaning and Maintenance*, page 19.
10. Do not allow fans to blow directly into the fireplace. Avoid any drafts that alter burner flame patterns. Ceiling fans can create drafts that alter burner flame patterns. Altered burner patterns can cause sooting.
11. Before using furniture polish, wax, carpet cleaner, or similar products, turn heater off. If heated, the vapors from these products may create a white powder residue within burner box or on adjacent walls or furniture.
12. Do not use a blower insert, heat exchanger insert or other accessory not approved for use with this heater.
13. This heater needs fresh, outside air ventilation to run properly. This heater has an oxygen depletion sensor (ODS) pilot light safety system. The ODS shuts down the heater if not enough fresh air is available. See *Air for Combustion and Ventilation*, pages 4 through 6. If heater keeps shutting off, see *Troubleshooting*, pages 20 through 22.
14. Do not run heater
  - where flammable liquids or vapors are used or stored
  - under dusty conditions
15. Do not use this heater to cook food or burn paper or other objects.
16. Never place any objects on the heater.
17. Heater base assembly becomes very hot when running heater. Keep children and adults away from hot surface to avoid burns or clothing ignition. Heater will remain hot for a time after shut-down. Allow surface to cool before touching.
18. Carefully supervise young children when they are in the room with heater.
19. Do not use heater if any part has been exposed to or under water. Immediately call a qualified service technician to inspect the room heater and to replace any part of the control system and any gas control which has been under water.
20. Do not operate heater if any log is broken. Do not operate heater if a log is chipped (dime-sized or larger).
21. Turn heater off and let cool before servicing. Only a qualified service person should service and repair heater.
22. Operating heater above elevations of 4,500 feet could cause pilot outage.

# OWNER'S MANUAL

## PRODUCT IDENTIFICATION

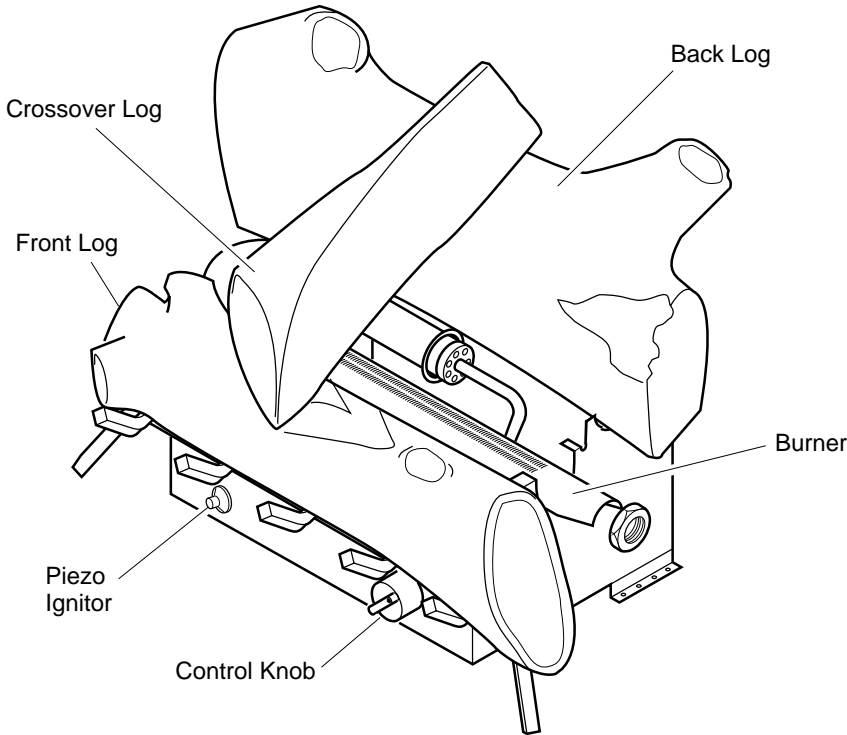


Figure 1 - Yellow Flame Vent-Free Gas Log Heater Shown (Logs May Vary by Model)

## LOCAL CODES

Install and use heater with care. Follow all local codes. In the absence of local codes, use the latest edition of *The National Fuel Gas Code ANS Z223.1*, also known as NFPA 54\*.

\*Available from:

American National Standards Institute, Inc.  
1430 Broadway  
New York, NY 10018

National Fire Protection Association, Inc.  
Batterymarch Park  
Quincy, MA 02269

**Note:** Where listed vented decorative logs are required, thermostat models are not permitted.

## UNPACKING

**⚠ WARNING:** Do not remove the metal Data Plates from the grate assembly. The Data Plates contain important product information.

1. Remove logs and heater base assembly from carton. **Note:** Do not pick up heater base assembly by burners. This could damage heater. Always handle base assembly by grate.
2. Remove all protective packaging applied to logs and heater for shipment.
3. Check all items for any shipping damage. If damaged, promptly inform dealer where you bought heater.

## PRODUCT FEATURES

### OPERATION

This heater is clean burning. It requires no outside venting. There is no heat loss out a vent or up a chimney. Heat is generated by realistic, dancing yellow flames. This heater is designed for vent-free operation with flue damper closed. It has been tested and approved to ANS Z21.11.2 standard for unvented heaters. State and local codes in some areas prohibit the use of vent-free heaters. Non-thermostat models may also be operated as a vented decorative (ANS Z21.60) product by opening flue damper.

### SAFETY PILOT

This heater has a pilot with an Oxygen Depletion Sensor Shutoff System (ODS). The ODS/pilot is a required feature for vent-free room heaters. The ODS/pilot shuts off the heater if there is not enough fresh air.

### PIEZO IGNITION SYSTEM

This heater has a piezo ignitor. This system requires no matches, batteries, or other sources to light heater.

## **UNVENTED NATURAL GAS LOG HEATER**

### **AIR FOR COMBUSTION AND VENTILATION**

**⚠ WARNING: This heater shall not be installed in a confined space or unusually tight construction unless provisions are provided for adequate combustion and ventilation air. Read the following instructions to insure proper fresh air for this and other fuel-burning appliances in your home.**

Today's homes are built more energy efficient than ever. New materials, increased insulation, and new construction methods help reduce heat loss in homes. Home owners weather strip and caulk around windows and doors to keep the cold air out and the warm air in. During heating months, home owners want their homes as airtight as possible.

While it is good to make your home energy efficient, your home needs to breathe. Fresh air must enter your home. All fuel-burning appliances need fresh air for proper combustion and ventilation.

Exhaust fans, fireplaces, clothes dryers, and fuel burning appliances draw air from the house to operate. You must provide adequate fresh air for these appliances. This will insure proper venting of vented fuel-burning appliances.

### **PROVIDING ADEQUATE VENTILATION**

The following are excerpts from *National Fuel Gas Code. NFPA 54/ANS Z223.1, Section 5.3, Air for Combustion and Ventilation.*

All spaces in homes fall into one of the three following ventilation classifications:

1. Unusually Tight Construction
2. Unconfined Space
3. Confined Space

The information on pages 4 through 6 will help you classify your space and provide adequate ventilation.

#### **Unusually Tight Construction**

The air that leaks around doors and windows may provide enough fresh air for combustion and ventilation. However, in buildings of unusually tight construction, you must provide additional fresh air.

**Unusually tight construction is defined as construction where:**

- a. walls and ceilings exposed to the outside atmosphere have a continuous water vapor retarder with a rating of one perm ( $6 \times 10^{-11}$  kg per pa-sec- $m^2$ ) or less with openings gasketed or sealed *and***
- b. weather stripping has been added on openable windows and doors *and***
- c. caulking or sealants are applied to areas such as joints around window and door frames, between sole plates and floors, between wall-ceiling joints, between wall panels, at penetrations for plumbing, electrical, and gas lines, and at other openings.**

**If your home meets all of the three criteria above, you must provide additional fresh air. See *Ventilation Air From Outdoors*, page 6.**

**If your home does not meet all of the three criteria above, proceed to *Determining Fresh-Air Flow For Heater Location* on page 5.**

### **Confined Space and Unconfined Space**

*The National Fuel Gas Code (ANS Z223.1, 1992 Section 5.3)* defines a confined space as a space whose volume is less than 50 cubic feet per 1,000 Btu per hour ( $4.8 \text{ m}^3$  per kw) of the aggregate input rating of all appliances installed in that space and an unconfined space as a space whose volume is not less than 50 cubic feet per 1,000 Btu per hour ( $4.8 \text{ m}^3$  per kw) of the aggregate input rating of all appliances installed in that space. Rooms communicating directly with the space in which the appliances are installed\*, through openings not furnished with doors, are considered a part of the unconfined space.

This heater shall not be installed in a confined space or unusually tight construction unless provisions are provided for adequate combustion and ventilation air.

\* Adjoining rooms are communicating only if there are doorless passageways or ventilation grills between them.

## AIR FOR COMBUSTION AND VENTILATION

*Continued*

### DETERMINING FRESH-AIR FLOW FOR HEATER LOCATION

#### Determining if You Have a Confined or Unconfined Space

Use this work sheet to determine if you have a confined or unconfined space.

**Space:** Includes the room in which you will install heater plus any adjoining rooms with doorless passageways or ventilation grills between the rooms.

1. Determine the volume of the space (length x width x height).

Length x Width x Height = \_\_\_\_\_ cu. ft. (volume of space)

*Example:* Space size 20 ft. (length) x 16 ft. (width) x 8 ft. (ceiling height) = 2560 cu. ft. (volume of space)

If additional ventilation to adjoining room is supplied with grills or openings, add the volume of these rooms to the total volume of the space.

2. Divide the space volume by 50 cubic feet to determine the maximum Btu/Hr the space can support.

\_\_\_\_\_ (volume of space) ÷ 50 cu. ft. = (Maximum Btu/Hr the space can support)

*Example:* 2560 cu. ft. (volume of space) ÷ 50 cu. ft. = 51.2 or 51,200 (maximum Btu/Hr the space can support)

3. Add the Btu/Hr of all fuel burning appliances in the space.

Vent-free heater \_\_\_\_\_ Btu/Hr

Gas water heater\* \_\_\_\_\_ Btu/Hr

Gas furnace \_\_\_\_\_ Btu/Hr

Vented gas heater \_\_\_\_\_ Btu/Hr

Gas fireplace logs \_\_\_\_\_ Btu/Hr

Other gas appliances\* + \_\_\_\_\_ Btu/Hr

Total = \_\_\_\_\_ Btu/Hr

*Example:*

Gas water heater 40,000 Btu/Hr

Vent-free heater + 31,500 Btu/Hr

Total = 71,500 Btu/Hr

\* Do not include direct-vent gas appliances. Direct-vent draws combustion air from the outdoors and vents to the outdoors.

4. Compare the maximum Btu/Hr the space can support with the actual amount of Btu/Hr used.

\_\_\_\_\_ Btu/Hr (maximum the space can support)

\_\_\_\_\_ Btu/Hr (actual amount of Btu/Hr used)

*Example:* 51,200 Btu/Hr (maximum the space can support)

71,500 Btu/Hr (actual amount of Btu/Hr used)

The space in the above example is a confined space because the actual Btu/Hr used is more than the maximum Btu/Hr the space can support. You must provide additional fresh air. Your options are as follows:

- A. Rework worksheet, adding the space of an adjoining room. If the extra space provides an unconfined space, remove door to adjoining room or add ventilation grills between rooms. See *Ventilation Air From Inside Building*, page 6.
- B. Vent room directly to the outdoors. See *Ventilation Air From Outdoors*, page 6.
- C. Install a lower Btu/Hr heater, if lower Btu/Hr size makes room unconfined.

If the actual Btu/Hr used is less than the maximum Btu/Hr the space can support, the space is an unconfined space. You will need no additional fresh air ventilation.

**⚠ WARNING: If the area in which the heater may be operated is smaller than that defined as an unconfined space or if the building is of unusually tight construction, provide adequate combustion and ventilation air by one of the methods described in the *National Fuel Gas Code, ANS Z223.1, 1992, Section 5.3* or applicable local codes.**

*Continued*

**UNVENTED NATURAL GAS LOG HEATER**

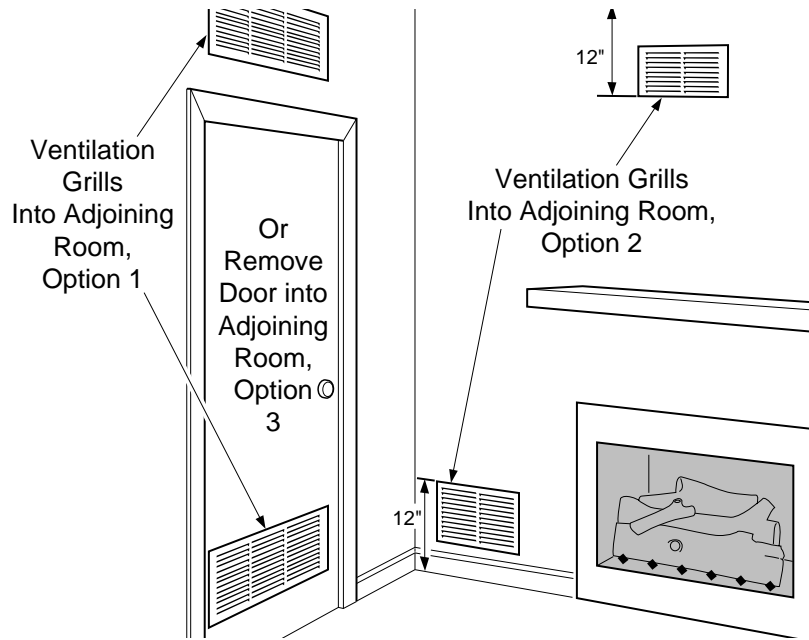
**AIR FOR  
COMBUSTION AND  
VENTILATION**

*Continued*

**VENTILATION AIR**

**Ventilation Air From Inside  
Building**

This fresh air would come from an adjoining unconfined space. When ventilating to an adjoining unconfined space, you must provide two permanent openings: one within 12" of the ceiling and one within 12" of the floor on the wall connecting the two spaces (see options 1 and 2, Figure 2). You can also remove door into adjoining room (see option 3, Figure 2). Follow the *National Fuel Gas Code NFPA 54/ANS Z223.1, Section 5.3, Air for Combustion and Ventilation* for required size of ventilation grills or ducts.



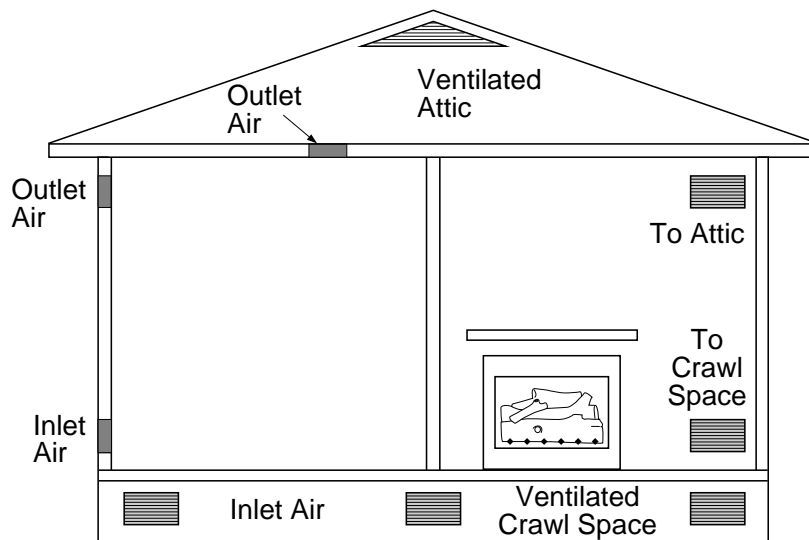
**Figure 2 - Ventilation Air from Inside Building**

**⚠ WARNING:** Rework worksheet, adding the space of the adjoining unconfined space. The combined spaces must have enough fresh air to supply all appliances in both spaces.

**Ventilation Air From Outdoors**

Provide extra fresh air by using ventilation grills or ducts. You must provide two permanent openings: one within 12" of the ceiling and one within 12" of the floor. Connect these items directly to the outdoors or spaces open to the outdoors. These spaces include attics and crawl spaces.

**IMPORTANT:** Do not provide openings for inlet or outlet air into attic if attic has a thermostat-controlled power vent. Heated air entering the attic will activate the power vent.



**Figure 3 - Ventilation Air from Outdoors**

# OWNER'S MANUAL

## INSTALLATION

**NOTICE:** This heater is intended for use as supplemental heat. Use this heater along with your primary heating system. Do not install this heater as your primary heat source. If you have a central heating system, you may run system's circulating blower while using heater. This will help circulate the heat throughout the house. In the event of a power outage, you can use this heater as your primary heat source.

**WARNING:** A qualified service person must install heater. Follow all local codes.

**NOTICE:** State or local codes may only allow operation of this appliance in a vented configuration. Check your state or local codes.

**WARNING:** Before installing in a solid fuel burning fireplace, the chimney flue and firebox must be cleaned of soot, creosote, ashes and loose paint by a qualified chimney cleaner. Creosote will ignite if highly heated. A dirty chimney flue may create and distribute soot within the house. Inspect chimney flue for damage. If damaged, operate heater with flue damper closed.

**WARNING:** Seal any fresh air vents or ash clean-out doors located on floor or wall of fireplace. If not, drafting may cause pilot outage or sooting. Use a heat-resistant sealant. Do not seal chimney flue damper.

**WARNING:** Never install the heater

- in a bedroom or bathroom unless installed as a vented appliance (Variable Manually-Controlled Models Only) (see page 10)
- in a recreational vehicle
- where curtains, furniture, clothing, or other flammable objects are less than 42 inches from the front, top, or sides of the heater
- in high traffic areas
- in windy or drafty areas

**CAUTION:** This heater creates warm air currents. These currents move heat to wall surfaces next to heater. Installing heater next to vinyl or cloth wall coverings or operating heater where impurities (such as tobacco smoke, aromatic candles, cleaning fluids, oil or kerosene lamps, etc.) in the air exist, may discolor walls.

**IMPORTANT:** Vent-free heaters add moisture to the air. Although this is beneficial, installing heater in rooms without enough ventilation air may cause mildew to form from too much moisture. See *Air for Combustion and Ventilation*, pages 4 through 6.

### CHECK GAS TYPE

Use only natural gas. If your gas supply is not natural gas, do not install heater. Call dealer where you bought heater for proper type heater.

## INSTALLATION AND CLEARANCES (Vent-Free Operation Only)

**WARNING:** Maintain the minimum clearances. If you can, provide greater clearances from floor, ceiling, and adjoining wall.

### MINIMUM FIREPLACE CLEARANCE TO COMBUSTIBLE MATERIALS

Log Size	Side Wall	Ceiling
18", 24"	16"	42"

### LOG SIZING REQUIREMENTS

Log Size	Minimum Firebox Size			
	Height	Depth	Front Width	Rear Width*
18"	17"	14"	24"	20"
24"	17"	14"	28"	21"

\*Measured at 14" depth.

Carefully follow the instructions below. This will ensure safe installation into a masonry, UL127 listed manufactured fireplace, or listed vent-free firebox.

### Minimum Wall and Ceiling Clearances (see Figure 4)

- Clearances from the side of the fireplace opening to any combustible wall should not be less than 16 inches.
- Clearances from the top of the fireplace opening to the ceiling should not be less than 42 inches.

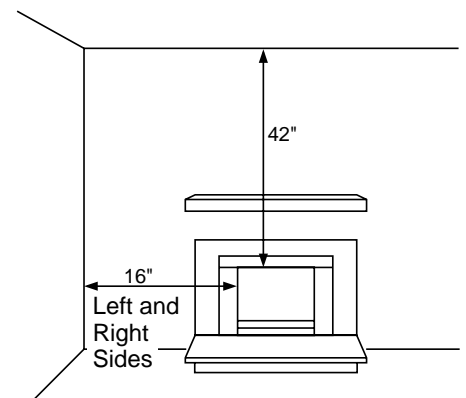


Figure 4 - Minimum Clearance to Wall and Ceiling

Continued

**UNVENTED NATURAL GAS LOG HEATER**

**INSTALLATION**

*Continued*

**NOTICE:** You may use non-thermostat heater as a vented product. If so, you must always run heater with chimney flue damper open. If running heater with damper open, noncombustible material above fireplace opening is not needed. Go to *Installing Damper Clamp Accessory for Vented Operation*, page 10

**Minimum Noncombustible Material Clearances**

**If Not Using Mantel**

*Note:* If using a mantel, proceed to *If Using Mantel*. If not using a mantel, follow the information below.

You must have noncombustible material(s) above the fireplace opening. Noncombustible materials (such as slate, marble, tile, etc.) must be at least 1/2 inch thick. With sheet metal, you must have noncombustible material behind it. Noncombustible material must extend at least 8" up (for all models). If noncombustible material is less than 12", you must install the fireplace hood accessory (24" model only). See Figure 5 at right for minimum clearances.

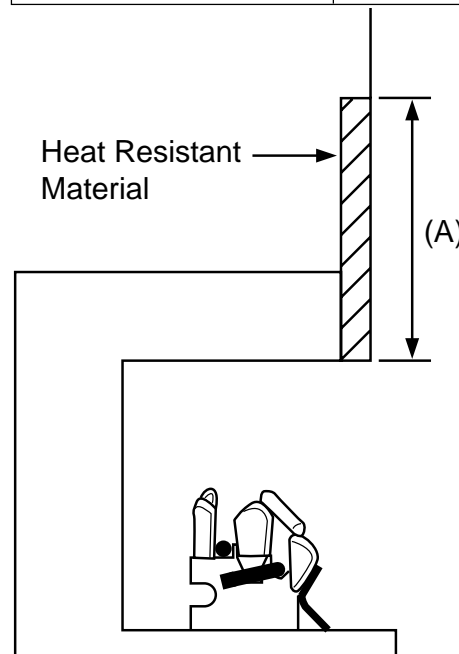
**IMPORTANT:** If you cannot meet these minimum clearances, you must operate heater with chimney flue damper open. Go to *Installing Damper Clamp Accessory for Vented Operation*, page 10.

**If Using Mantel**

You must have noncombustible material(s) above the fireplace opening. Noncombustible materials (such as slate, marble, tile, etc.) must be at least 1/2 inch thick. With sheet metal, you must have noncombustible material behind it. Noncombustible material must extend at least 8 inches up (for all models). If noncombustible material is less than 12", you must install the fireplace hood accessory (24" model only). Even if noncombustible material is more than 12", you may need the hood accessory to deflect heat away from your mantel shelf. See Figure 5 and Figures 6 and 7 on page 9 for minimum clearances.

**IMPORTANT:** If you cannot meet these minimum clearances, you must operate heater with chimney flue damper open. Go to *Installing Damper Clamp Accessory for Vented Operation*, page 10.

Noncombustible Material Distance (A)	Requirements for Safe Installation
12" or more	Noncombustible material okay.
Between 8" and 12"	24" Model: Install fireplace hood accessory (GA6050, GA6052, or GA6053, see <i>Accessories</i> , page 25). 18" Model: Noncombustible material okay.
Less than 8"	Noncombustible material must be extended to at least 8". See <i>Between 8" and 12"</i> , above. If you cannot extend material, you must operate heater with flue damper open.



**Figure 5 - Heat Resistant Material (Slate, Marble, Tile, etc.) Above Fireplace**



## INSTALLATION

*Continued*

### MANTEL CLEARANCES

In addition to meeting noncombustible material clearances, you must also meet required clearances between fireplace opening and mantel shelf. If you do not meet the clearances listed below, you will need a hood.

#### Determining Minimum Mantel Clearance

If you meet minimum clearance between mantel shelf and top of fireplace opening, a hood is not required (see Figure 6).

#### Determining Minimum Mantel Clearances when Using a Hood

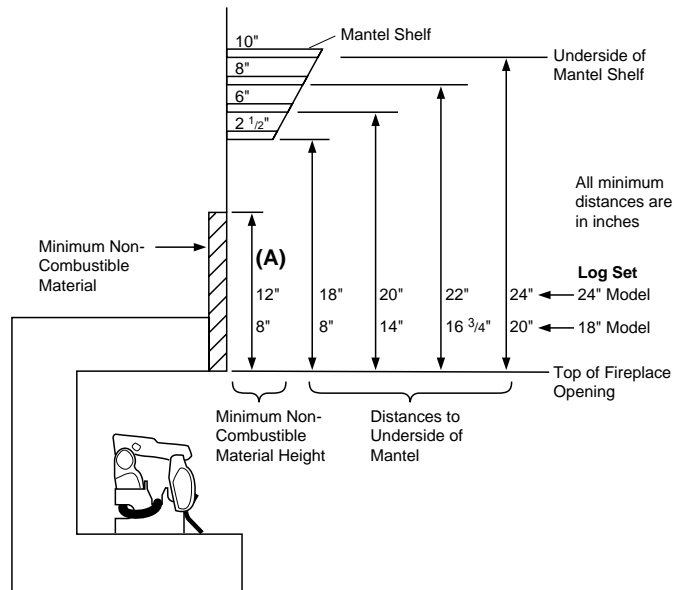
If minimum clearances in Figure 6 are not met, you must have a hood. When using a hood there are still certain minimum mantel clearances required. Follow minimum clearances shown in Figure 7 when using a hood.

**NOTICE: If your installation does not meet the minimum clearances shown, you must do one of the following:**

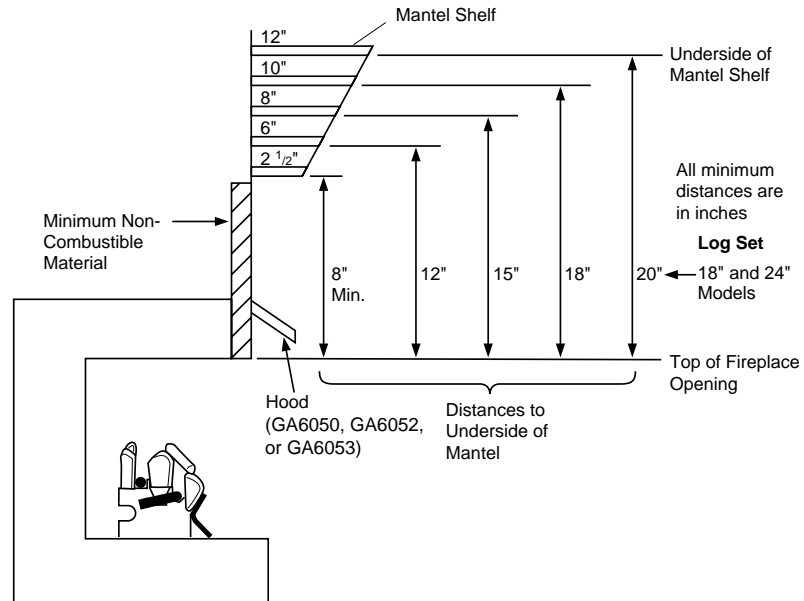
- operate the logs only with the flue damper open
- raise the mantel to an acceptable height
- remove the mantel

### FLOOR CLEARANCES

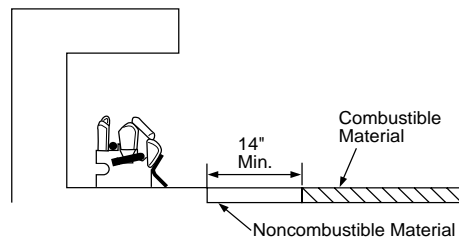
- If installing appliance on the floor level, you must maintain the minimum distance of 14" to combustibles (see Figure 8).
- If combustible materials are less than 14" to the fireplace, you must install appliance at least 5" above the combustible flooring (see Figure 9).



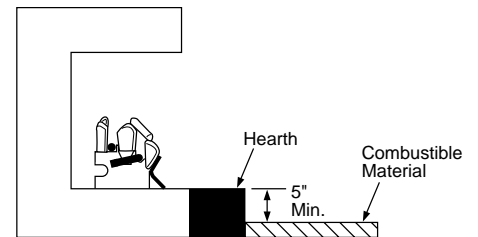
**Figure 6 - Minimum Mantel Clearances Without Using Hood**



**Figure 7 - Minimum Mantel Clearances When Using Hood**



**Figure 8 - Minimum Fireplace Clearances If Installed at Floor Level**



**Figure 9 - Minimum Fireplace Clearances Above Combustible Flooring**

*Continued*

**UNVENTED NATURAL GAS LOG HEATER**

**INSTALLATION**

*Continued*

**INSTALLING DAMPER CLAMP ACCESSORY FOR VENTED OPERATION**

*Note:* When used as a vented heater, appliance must be installed only in a solid-fuel burning fireplace with a working flue and constructed of noncombustible material.

If your heater is a manually controlled model, you may use this heater as a vented product. There are three reasons for operating your heater in the vented mode.

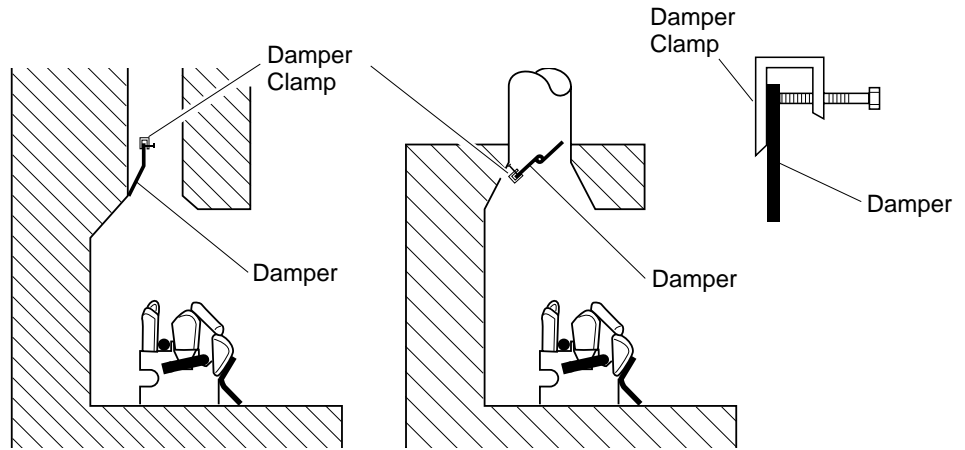
1. The fireplace does not meet the clearance to combustibles requirements for vent-free operation.
2. State or local codes do not permit vent-free operation.
3. You prefer vented operation.

If reasons number 1 or 2 above apply to you, you must permanently open chimney flue damper. You must install the damper clamp accessory (to order, see *Accessories*, page 25). This will insure vented operation (see Figure 10). The damper clamp will keep damper open. Installation instructions are included with clamp accessory.

See chart below for minimum permanent flue opening you must provide. Attach damper clamp so the minimum permanent flue opening will be maintained at all times.

Chimney Height (ft.)	Minimum Permanent Flue Opening (sq. ins.)
6' to 15'	39 sq. inches
15' to 30'	29 sq. inches

Area of Various Standard Round Flues	
Diameter (ins.)	Area (sq. ins.)
5"	20 sq. inches
6"	29 sq. inches
7"	39 sq. inches
8"	51 sq. inches



**Masonry Fireplace      Manufactured Fireplace**  
**Figure 10 - Attaching Damper Clamp**

**INSTALLING HEATER BASE ASSEMBLY**

**WARNING:** You must secure this heater to fireplace floor. If not, heater will move when you adjust controls. Moving heater may cause a gas leak.

**WARNING:** If installing in a sunken fireplace, special care is needed. You must raise the fireplace floor to allow access to heater control panel. This will insure adequate air flow and guard against sooting. Raise fireplace floor with noncombustible material. Make sure material is secure.

**CAUTION:** Do not pick up heater base assembly by the burner. This could damage heater. Only handle base assembly by grates.

**CAUTION:** Do not remove the metal Data Plates attached to the heater base assembly. The Data Plates contain important warranty information.

**IMPORTANT:** Make sure the heater burners are level. If heater is not level, heater will not work properly. For thermostat models, avoid damage to thermostat bulb. Avoid nicks or sharp bends in thermostat bulb wire. Keep thermostat bulb in mounting bracket.

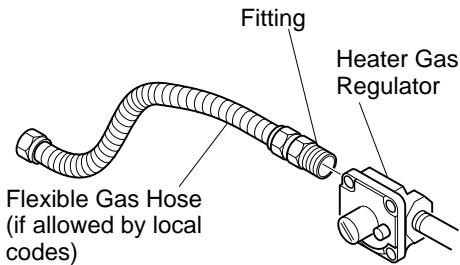
**Installation Items Needed**

- hardware package (provided with heater)
  - approved flexible gas hose (not provided) (if allowed by local codes)
  - sealant (resistant to propane/LP gas, not provided)
  - electric drill with 3/16" drill bit
1. Apply pipe joint sealant lightly to male threads of the fitting to be threaded into gas regulator. Connect approved flexible gas hose to gas regulator of heater (see Figure 11, page 12).  
*IMPORTANT:* Hold gas regulator with wrench when connecting flexible gas hose.
  2. Locate masonry screws in hardware package.
  3. Position heater base assembly in fireplace.
  4. Mark screw locations through holes in mounting brackets (see Figure 12, page 12). If installing in a brick-bottom fireplace, mark screw locations in mortar joint of bricks.
  5. Remove heater base from fireplace.

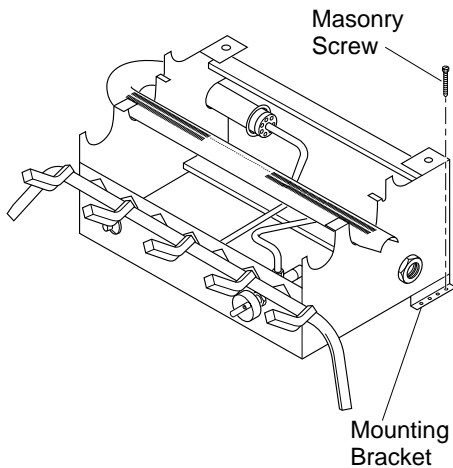
## INSTALLATION

### Continued

6. Drill holes at marked locations using 3/16" drill bit.
7. Attach base assembly to fireplace floor using two masonry screws (in hardware package) (see Figure 12).
8. Connect to gas supply. See *Connecting To Gas Supply*.



**Figure 11 - Attaching Flexible Gas Hose to Heater Gas Regulator**



**Figure 12 - Attaching Base Assembly to Fireplace Floor**

## CONNECTING TO GAS SUPPLY

**⚠ WARNING: A qualified service person must connect heater to gas supply. Follow all local codes.**

### Installation Items Needed

Before installing heater, make sure you have the items listed below.

- piping (check local codes)
- sealant (resistant to propane/LP gas)
- manual shutoff valve \*
- test gauge connection \*
- sediment trap
- tee joint
- pipe wrench

\* An A.G.A. design-certified manual shutoff valve with 1/8" NPT tap is an acceptable alternative to test gauge connection. Purchase the optional A.G.A. design-certified manual shutoff valve from your dealer. See *Accessories*, page 25.

**⚠ WARNING: Never connect heater to private (non-utility) gas wells. This gas is commonly known as well-head gas.**

**⚠ CAUTION: Use only new, black iron or steel pipe. Internally-tinned copper tubing may be used in certain areas. Check your local codes. Use pipe of 1/2" diameter or greater to allow proper gas volume to heater. If pipe is too small, undue loss of pressure will occur.**

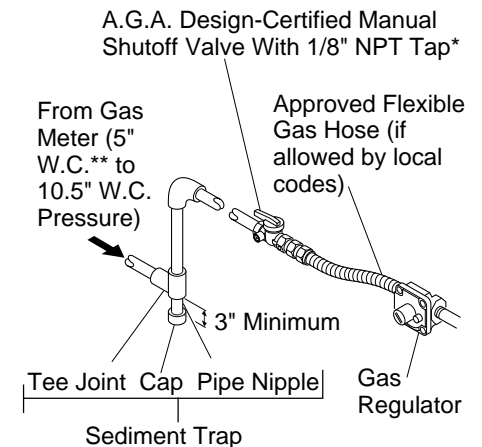
Installation must include a manual shutoff valve, union, and plugged 1/8" NPT tap. Locate NPT tap within reach for test gauge hook up. NPT tap must be upstream from heater (see Figure 13).

Apply pipe joint sealant lightly to male threads. This will prevent excess sealant from going into pipe. Excess sealant in pipe could result in clogged heater valves.

**⚠ CAUTION: Use pipe joint sealant that is resistant to liquid petroleum (LP) gas.**

Install sediment trap in supply line as shown in Figure 13. Locate sediment trap where it is within reach for cleaning. Locate sediment trap where trapped matter is not likely to freeze. A sediment trap traps moisture and contaminants. This keeps them from going into heater controls. If sediment trap is not installed or is installed wrong, heater may not run properly.

**⚠ CAUTION: Avoid damage to regulator. Hold gas regulator with wrench when connecting it to gas piping and/or fittings.**



**Figure 13 - Gas Connection**

\* Purchase the optional A.G.A. design-certified manual shutoff valve from your dealer. See *Accessories*, page 25.

\*\* Minimum inlet pressure for purpose of input adjustment.

**UNVENTED NATURAL GAS LOG HEATER**

**INSTALLATION**

*Continued*

**CHECKING GAS CONNECTIONS**

**⚠ WARNING: Test all gas piping and connections for leaks after installing or servicing. Correct all leaks at once.**

**⚠ WARNING: Never use an open flame to check for a leak. Apply a mixture of liquid soap and water to all joints. Bubbles forming show a leak. Correct all leaks at once.**

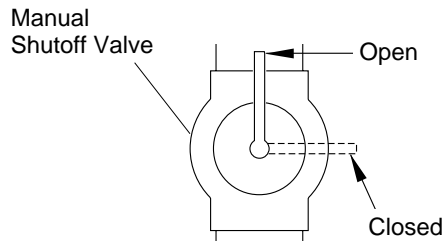
**Pressure Testing gas Supply Piping system**

**Test Pressures In Excess Of 1/2 PSIG**

1. Disconnect heater and its individual manual shutoff valve from gas supply piping system. Pressures in excess of 1/2 psig will damage heater regulator.
2. Cap off open end of gas pipe where manual shutoff valve was connected.
3. Pressurize supply piping system by either using compressed air or opening main gas valve located on or near gas meter.
4. Check all joints of gas supply piping system. Apply mixture of liquid soap and water to gas joints. Bubbles forming show a leak.
5. Correct all leaks at once.
6. Reconnect heater and manual shutoff valve to gas supply. Check reconnected fittings for leaks.

**Test Pressures Equal To or Less Than 1/2 PSIG**

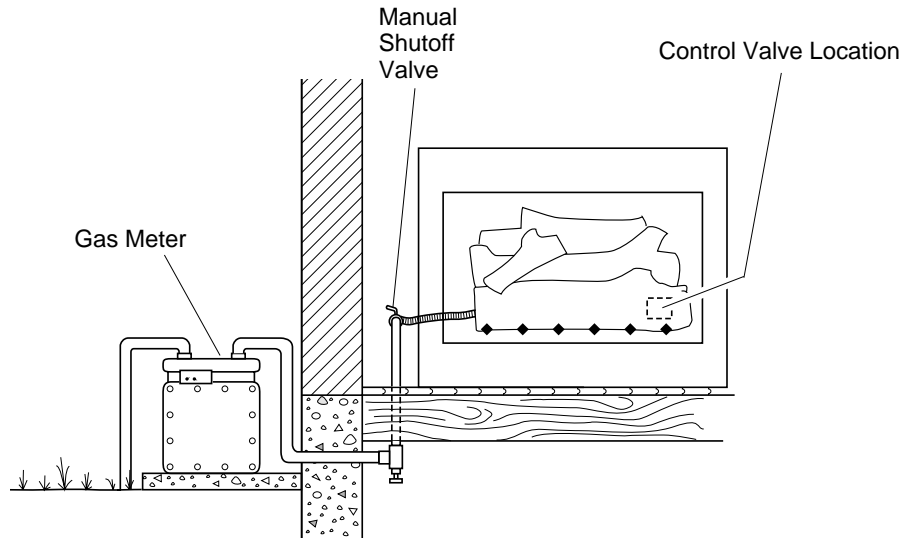
1. Close manual shutoff valve (see Figure 14).
2. Pressurize supply piping system by either using compressed air or opening main gas valve located on or near gas meter.
3. Check all joints from gas meter to manual shutoff valve (see Figure 15). Apply mixture of liquid soap and water to gas joints. Bubbles forming show a leak.
4. Correct all leaks at once.



**Figure 14 - Manual Shutoff Valve**

**Pressure Testing Heater Gas Connections**

1. Open manual shutoff valve (see Figure 14).
2. Open main gas valve located on or near gas meter.
3. Make sure control knob of heater is in the OFF position.
4. Check all joints from manual shutoff valve to control valve (see Figure 15). Apply mixture of liquid soap and water to gas joints. Bubbles forming show a leak.
5. Correct all leaks at once.
6. Light heater (see *Operating Heater*, pages 16 and 17 [manually-controlled models] or pages 17 and 18 [thermostatically-controlled models]). Check all other internal joints for leaks.
7. Turn off heater (see *To Turn Off Gas to Appliance*, page 17 [manually-controlled models] or page 18 [thermostatically-controlled models]).



**Figure 15 - Checking Gas Joints**

## INSTALLATION

### Continued

### INSTALLING LOGS ON MODELS CGS2718N AND CGS3124N

**⚠ WARNING:** Failure to position the parts in accordance with these diagrams or failure to use only parts specifically approved with this heater may result in property damage or personal injury.

**⚠ CAUTION:** After installation and periodically thereafter, check to ensure that no flame comes in contact with any log. With the heater set to High, check to see if flames contact any log. If so, reposition logs according to the log installation instructions in this manual. Flames contacting logs will create soot.

Each log is marked with a number. These numbers will help you identify the log when installing. It is very important to install these logs exactly as instructed. Do not modify logs. Only use logs supplied with heater.

1. Locate pegs on the bottom of back log (#1). Slide these pegs into the holes in the grate base behind the burner (see Figure 16).
2. Locate the notches on the back of the front log (#2). Slide these notches over the tabs of the grate base (see Figure 17).
3. Locate the notches in the bottom of the crossover log (#3). Place the crossover log on top of the back log and front log. Make sure the notches of the crossover log line up with rectangular knobs on top of the back and front logs (see Figure 18).
4. Add lava rock around base of heater. Do not place lava rock on logs or burner.

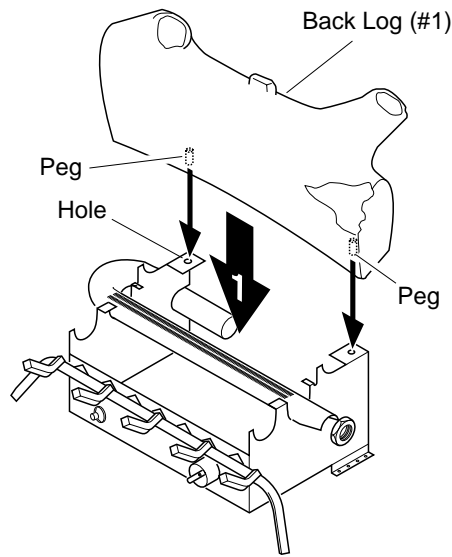


Figure 16 - Installing Back Log

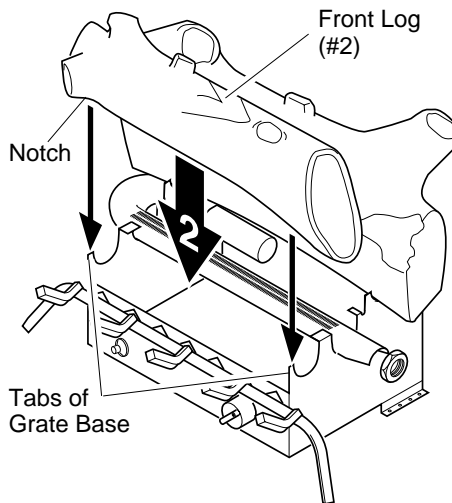


Figure 17 - Installing Front Log

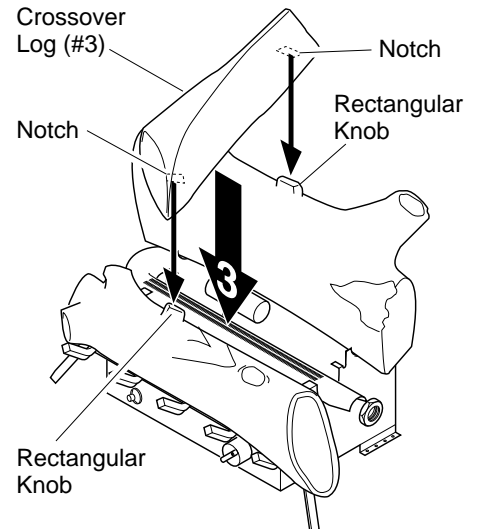


Figure 18 - Installing Crossover Log

Continued

**UNVENTED NATURAL GAS LOG HEATER**

**INSTALLATION**

*Continued*

**INSTALLING LOGS ON  
MODELS CLD3018N AND  
CLD3924NT**

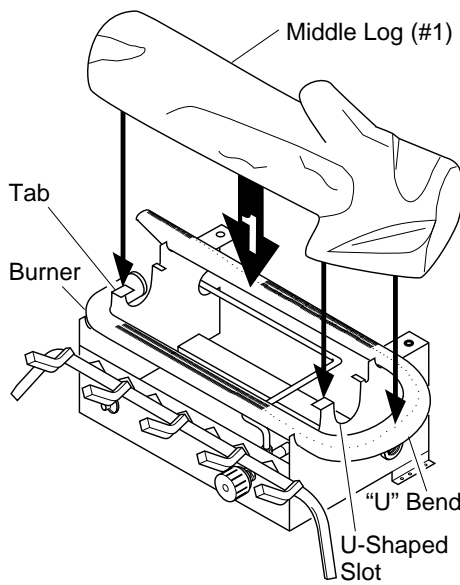
**⚠ WARNING:** Failure to position the parts in accordance with these diagrams or failure to use only parts specifically approved with this heater may result in property damage or personal injury.

**⚠ CAUTION:** After installation and periodically thereafter, check to ensure that no flame comes in contact with any log. With the heater set to High, check to see if flames contact any log. If so, reposition logs according to the log installation instructions in this manual. Flames contacting logs will create soot.

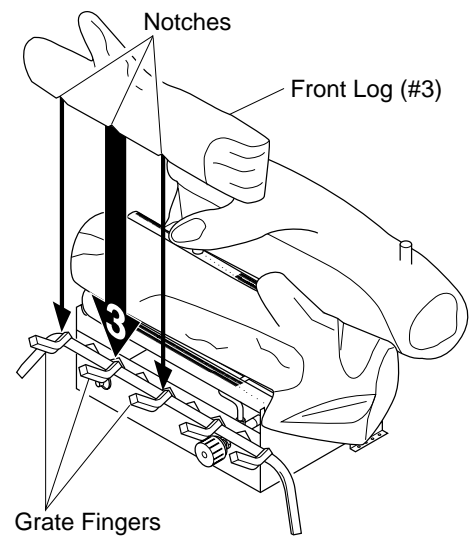
Each log is marked with a number. These numbers will help you identify the log when installing. It is very important to install these logs exactly as instructed. Do not modify logs. Only use logs supplied with heater.

1. Place the base of the middle log (#1) in the U-shaped slots of the grate base. The cutout on the right of the middle log should fit over the burner (see Figure 19). Make sure the front of the middle log is resting on the tabs of the grate base and the cutout area is centered over the burner "U" bend.
2. Locate pegs on the bottom of back log (#2). Slide these pegs into the holes in the grate base behind the burner (see Figure 20).

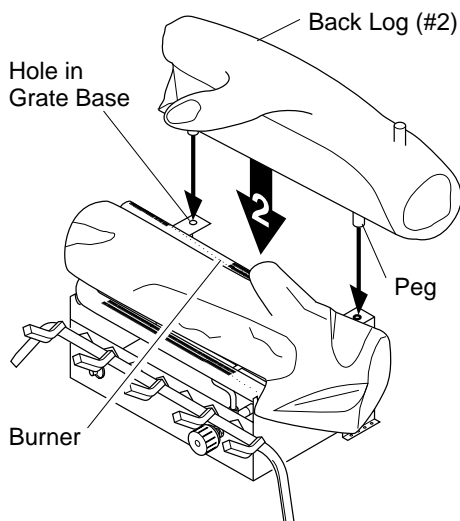
3. Locate the notches in the bottom of the front log (#3). Place the front log on the grate fingers. Make sure the notches of the front log line up with the grate fingers (see Figure 21).
4. Place crossover log (#4) onto the pin (right) on back log (#2) and into the recess of the middle log (#1) (see Figure 22).
5. Add lava rock around base of heater. Do not place any lava rock on logs or burner.



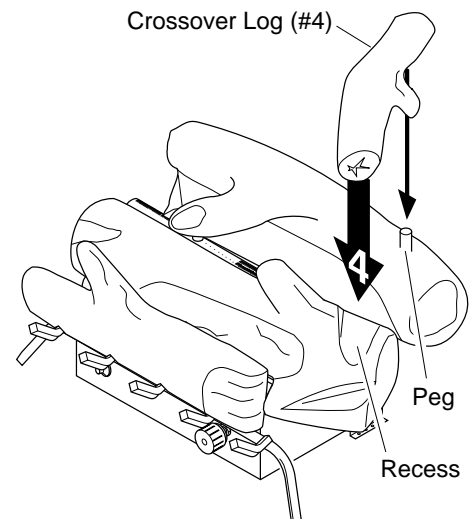
**Figure 19 - Installing Middle Log (#1)**



**Figure 21 - Installing Front Log (#3)**



**Figure 20 - Installing Back Log (#2)**



**Figure 22 - Installing Crossover Log (#4)**

## INSTALLATION

*Continued*

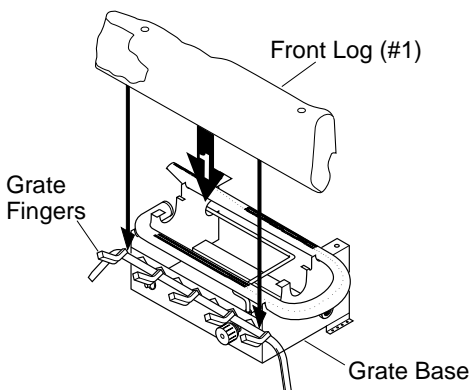
### INSTALLING LOGS ON MODEL CCL3930NT(A)

**⚠ WARNING:** Failure to position the parts in accordance with these diagrams or failure to use only parts specifically approved with this heater may result in property damage or personal injury.

**⚠ CAUTION:** After installation and periodically thereafter, check to ensure that no flame comes in contact with any log. With the heater set to High, check to see if flames contact any log. If so, reposition logs according to the log installation instructions in this manual. Flames contacting logs will create soot.

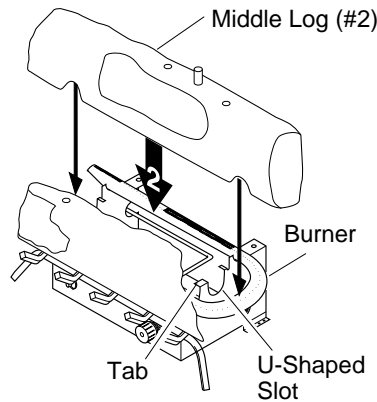
Each log is marked with a number. These numbers will help you identify the log when installing. It is very important to install these logs exactly as instructed. Do not modify logs. Only use logs supplied with heater.

1. Place the front log (#1) on the grate fingers. Make sure the front log rest firmly between the grate fingers and the grate base (see Figure 23).
2. Place the base of the middle log (#2) in the U-shaped slots of the grate base. The cutout on the right of the middle log should fit over the burner (see Figure 24). Make sure the front of the middle log is resting on the tabs of the grate base.
3. Locate pegs on the bottom of back log (#3). Slide these pegs into the holes in the grate base behind the burner (see Figure 25).

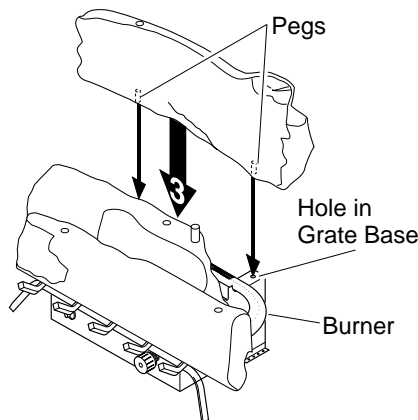


**Figure 23 - Installing Front Log (#1)**

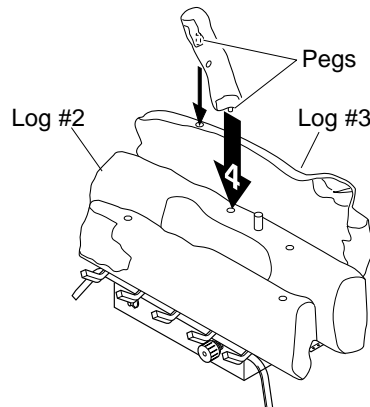
4. Locate pegs on the bottom of crossover log (#4). Slide these pegs into the holes located in middle log (#2) and back log (#3). See Figure 26 for placement.
5. Locate pegs on the bottom of crossover log (#5). Slide these pegs into the holes located in crossover log (#4) and front log (#1). See Figure 27.



**Figure 24 - Installing Middle Log (#2)**

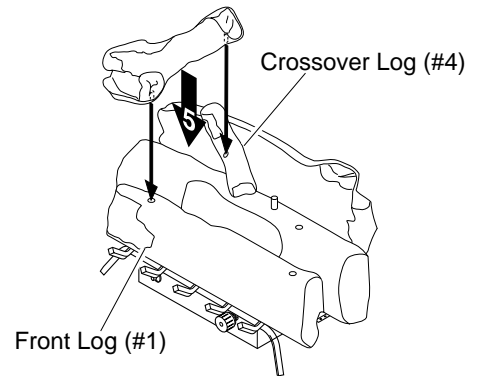


**Figure 25 - Installing Back Log (#3)**

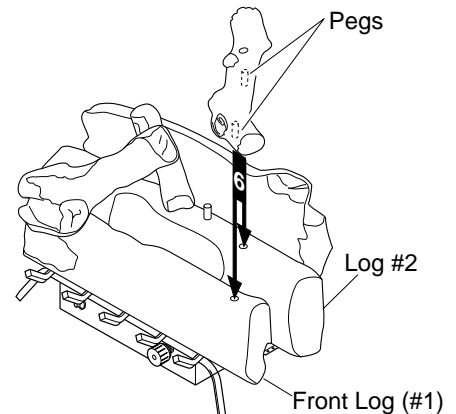


**Figure 26 - Installing Crossover Log (#4)**

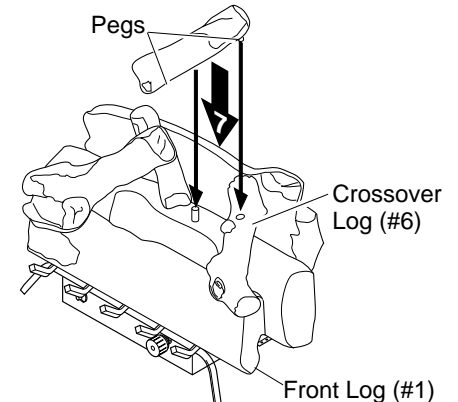
6. Locate pegs on the bottom of crossover log (#6). Slide these pegs into the holes located in back log (#3) and front log (#1). See Figure 28.
7. Locate pegs on the bottom of crossover log (#7). Slide these pegs into the holes located in crossover log (#6) and front log (#1). See Figure 29.
8. Add lava rock around base of heater. Do not place any lava rock on logs or burner.



**Figure 27 - Installing Crossover Log (#5)**



**Figure 28 - Installing Crossover Log (#6)**



**Figure 29 - Installing Crossover Log (#7)**

**UNVENTED NATURAL GAS LOG HEATER**

**OPERATING  
HEATER**

**Manually-Controlled Models**

**FOR YOUR SAFETY  
READ BEFORE  
LIGHTING**

**⚠ WARNING:** If you do not follow these instructions exactly, a fire or explosion may result causing property damage, personal injury or loss of life.

- A. This appliance has a pilot which must be lighted by hand. When lighting the pilot, follow these instructions exactly.
- B. **BEFORE LIGHTING** smell all around the appliance area for gas. Be sure to smell next to the floor because some gas is heavier than air and will settle on the floor.

**WHAT TO DO IF YOU SMELL GAS**

- Do not try to light any appliance.
  - Do not touch any electric switch; do not use any phone in your building.
  - Immediately call your gas supplier from a neighbor's phone. Follow the gas supplier's instructions.
  - If you cannot reach your gas supplier, call the fire department.
- C. Use only your hand to push in or turn the gas control knob. Never use tools. If the knob will not push in or turn by hand, don't try to repair it, call a qualified service technician or gas supplier. Force or attempted repair may result in a fire or explosion.
  - D. Do not use this appliance if any part has been under water. Immediately call a qualified service technician to inspect the appliance and to replace any part of the control system and any gas control which has been under water.

**LIGHTING  
INSTRUCTIONS**

**⚠ WARNING:**

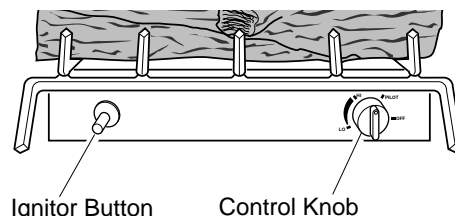
- If fireplace has glass doors, never operate this heater with glass doors closed. If you operate heater with doors closed, heat buildup inside fireplace will cause glass to burst. Also if fireplace opening has vents at the bottom, you must open the vents before operating heater.
- You must operate this heater with a fireplace screen in place. Make sure fireplace screen is closed before running heater.

**NOTICE:** During initial operation of new heater, burning logs will give off a paper-burning smell. Orange flame will also be present. Open damper or window to vent smell. This will only last a few hours.

**Note:** Home owners generally prefer to operate their heater with the chimney damper closed. This will put all the heat into the room. However, there may be times you will desire the full flames of the Hi heat setting but will find the heat output excessive. You can open the chimney damper (if you have one) fully or partially to release some of the heat.

**⚠ WARNING:** Damper handle will be hot if heater has been running.

1. **STOP!** Read the safety information above.
2. Make sure manual shutoff valve is fully open.
3. Press in and turn control knob clockwise to the OFF position.



**Figure 30 - Control Knob and Ignitor Button Location**

4. Wait five (5) minutes to clear out any gas. Then smell for gas, including near the floor. If you smell gas, **STOP!** Follow "B" in the safety information. If you don't smell gas, go to the next step.
5. Slightly depress and turn control knob counterclockwise to the PILOT position. Press in control knob for five (5) seconds (see Figure 30).

**Note:** You may be running this heater for the first time after hooking up to gas supply. If so, the control knob may need to be pressed in for 30 seconds. This will allow air to bleed from the gas system.

6. With control knob pressed in, press and release ignitor button. This will light pilot. The pilot is attached to the burner. If needed, keep pressing ignitor button until pilot lights.

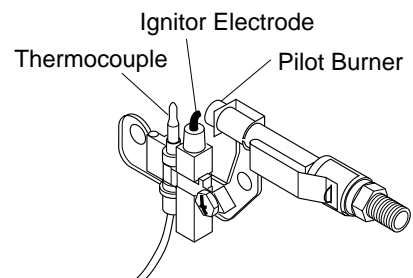
**Note:** If pilot does not stay lit, contact a qualified service person or gas supplier for repairs. Until repairs are made, light pilot with match. To light pilot with match, see *Manual Lighting Procedure*, page 17.

7. Keep control knob pressed in for 30 seconds after lighting pilot. After 30 seconds, release control knob.

**Note:** If pilot goes out, repeat steps 3 through 7.

- If control knob does not pop out when released, contact a qualified service person or gas supplier for repairs.
8. Slightly depress and turn control knob counterclockwise to desired heating level. The burner should light. Set control knob to any heat level between HI and LO.

**⚠ WARNING:** Do not operate heater between PILOT and HIGH positions.



**Figure 31 - Pilot**



## OPERATING HEATER

*Continued*




### VARIABLE CONTROL OPERATION

The variable control valve can be set to any heat setting and flame height desired, by simply turning the control knob until that setting is attained. Even the lowest setting provides realistic, dancing yellow flames. Selecting higher settings produces greater heat output. This results in increased heating comfort.



**CAUTION:** Do not try to adjust heating levels by using the manual shutoff valve.

### TO TURN OFF GAS TO APPLIANCE

#### Shutting Off Heater

1. Press in and turn control knob clockwise  to the HIGH position.
2. Turn control knob clockwise  to the pilot position.
3. Press in control knob and turn clockwise  to the OFF position.

#### Shutting Off Burners Only (pilot stays lit)

1. Turn control knob clockwise  to the HIGH position.
2. Press in and turn control knob clockwise  to the pilot position.

### MANUAL LIGHTING PROCEDURE

1. Follow steps 1 through 5 under *Lighting Instructions*, page 16.
2. Depress control knob and light pilot with match.
3. Keep control knob pressed in for 30 seconds after lighting pilot. After 30 seconds, release control knob. Now follow step 8 on page 16.

## Thermostatically-Controlled Models

### FOR YOUR SAFETY READ BEFORE LIGHTING

**WARNING:** If you do not follow these instructions exactly, a fire or explosion may result causing property damage, personal injury or loss of life.

- A. This appliance has a pilot which must be lighted by hand. When lighting the pilot, follow these instructions exactly.
- B. BEFORE LIGHTING smell all around the appliance area for gas. Be sure to smell next to the floor because some gas is heavier than air and will settle on the floor.

#### WHAT TO DO IF YOU SMELL GAS

- Do not try to light any appliance.
  - Do not touch any electric switch; do not use any phone in your building.
  - Immediately call your gas supplier from a neighbor's phone. Follow the gas supplier's instructions.
  - If you cannot reach your gas supplier, call the fire department.
- C. Use only your hand to push in or turn the gas control knob. Never use tools. If the knob will not push in or turn by hand, don't try to repair it, call a qualified service technician or gas supplier. Force or attempted repair may result in a fire or explosion.
  - D. Do not use this appliance if any part has been under water. Immediately call a qualified service technician to inspect the appliance and to replace any part of the control system and any gas control which has been under water.

## LIGHTING INSTRUCTIONS


### WARNING

- If fireplace has glass doors, never operate this heater with glass doors closed. If you operate heater with doors closed, heat buildup inside fireplace will cause glass to burst. Also if fireplace opening has vents at the bottom, you must open the vents before operating heater.
- You must operate this heater with a fireplace screen in place. Make sure fireplace screen is closed before running heater.

**NOTICE:** During initial operation of new heater, burning logs will give off a paper-burning smell. Orange flame will also be present. Open damper or window to vent smell. This will only last a few hours.

**Note:** Home owners generally prefer to operate their heater with the chimney damper closed. This will put all the heat into the room. However, there may be times you will desire the full flames of the Hi heat setting but will find the heat output excessive. You can open the chimney damper (if you have one) fully or partially to release some of the heat.

**WARNING:** Damper handle will be hot if heater has been running.

1. STOP! Read the safety information above.
2. Make sure manual shutoff valve is fully open.
3. Turn control knob clockwise  to the OFF position.
4. Wait five (5) minutes to clear out any gas. Then smell for gas, including near the floor. If you smell gas, STOP! Follow "B" in the safety information above. If you don't smell gas, go to the next step.

*Continued*

**UNVENTED NATURAL GAS LOG HEATER**

**OPERATING HEATER**

*Continued*

- Turn control knob counterclockwise to the PILOT position. Press in control knob for five (5) seconds (see Figure 32).

**Note:** You may be running this heater for the first time after hooking up to gas supply. If so, the control knob may need to be pressed in for 30 seconds or less. This will allow air to bleed from the gas system.

- If control knob does not pop out when released, contact a qualified service person or gas supplier for repairs.

- With control knob pressed in, press and release ignitor button. This will light pilot. The pilot is attached to the front burner. If needed, keep pressing ignitor button until pilot lights.

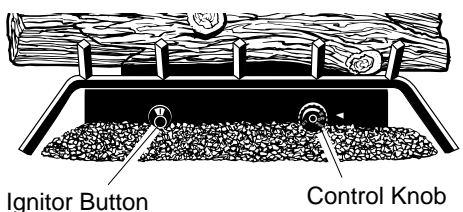
**Note:** If pilot does not stay lit, contact a qualified service person or gas supplier for repairs. Until repairs are made, light pilot with match. To light pilot with match, see *Manual Lighting Procedure*.

- Keep control knob pressed in for 30 seconds after lighting pilot. After 30 seconds, release control knob.

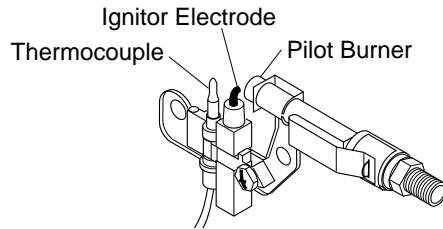
**Note:** If pilot goes out, repeat steps 3 through 7. This heater has a safety interlock system. Wait one (1) minute for system to reset before lighting pilot again.

- Turn control knob counterclockwise to desired heating level. The burners should light. Set control knob to any heat level between HI and LO.

**CAUTION:** Do not try to adjust heating levels by using the manual shutoff valve.



**Figure 32 - Control Knob and Ignitor Button Location**



**Figure 33 - Pilot**

**TO TURN OFF GAS TO APPLIANCE**  
**Shutting Off Heater**

Turn control knob clockwise to the OFF position.

**Shutting Off Burners Only (pilot stays lit)**

Turn control knob clockwise to the PILOT position.

**THERMOSTAT CONTROL OPERATION**  
**(Thermostat-Controlled Models Only)**

The thermostat control knob can be set to any comfort level between Hi and Lo. The thermostat will gradually modulate the heat output and flame height from higher to lower settings, or pilot, in order to maintain the comfort level you select. The ideal comfort setting will vary by household depending upon the amount of space to be heated, the output of the central heating system, etc.

**Note:** Selecting the Hi setting with the control knob will cause the burner to remain fully on, without modulating down in most cases.

**MANUAL LIGHTING PROCEDURE**

- Follow steps 1 through 5 under *Lighting Instructions*, pages 16 and 17.
- Depress control knob and light pilot with match.
- Keep control knob pressed in for 30 seconds after lighting pilot. After 30 seconds, release control knob. Now follow step 8 under *Lighting Instructions*, column 1.

**INSPECTING BURNERS**

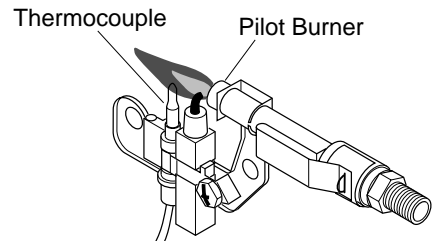
Check pilot flame pattern and burner flame patterns often.

**PILOT FLAME PATTERN**

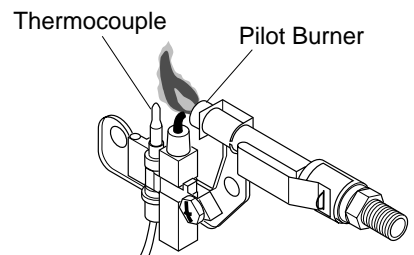
Figure 34 shows a correct pilot flame pattern. Figure 35 shows an incorrect pilot flame pattern. The incorrect pilot flame is not touching the thermocouple. This will cause the thermocouple to cool. When the thermocouple cools, the heater will shut down.

If pilot flame pattern is incorrect, as shown in Figure 35

- turn heater off (see *To Turn Off Gas to Appliance*, page 17 [manually-controlled models] or column 2, this page [thermostat-controlled models])
- see *Troubleshooting*, pages 20 through 22



**Figure 34 - Correct Pilot Flame Pattern**



**Figure 35 - Incorrect Pilot Flame Pattern**

**BURNER PRIMARY AIR HOLES**

Air is drawn into the burner through the holes in the fitting at the entrance to the burner. These holes may become blocked with dust or lint. Periodically inspect these holes for any blockage and clean as necessary. Blocked air holes will create soot.

## INSPECTING BURNERS

*Continued*

### MAIN BURNER

Periodically inspect all burner flame holes with the heater running. All slotted burner flame holes should be open with yellow flame present. All round burner flame holes should be open with a small blue flame present. Some burner flame holes may become blocked by debris or rust, with no flame present. If so, turn off heater and let cool. Either remove blockage or replace burner. Blocked burner flame holes will create soot.

## CLEANING AND MAINTENANCE

**⚠ WARNING:** Turn off heater and let cool before cleaning.

**⚠ CAUTION:** You must keep control areas, burner, and circulating air passageways of heater clean. Inspect these areas of heater before each use. Have heater inspected yearly by a qualified service person. Heater may need more frequent cleaning due to excessive lint from carpeting, bedding material, pet hair, etc.

### ODS/PILOT AND BURNER

- Use a vacuum cleaner or small, soft bristled brush to clean.

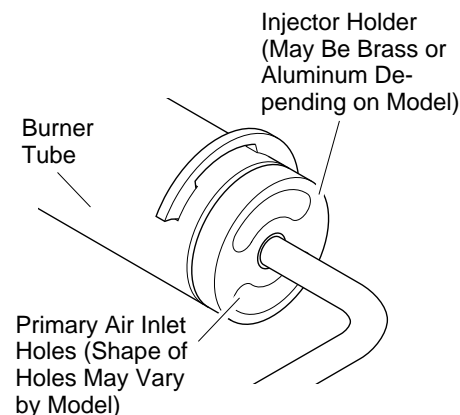
### CLEANING BURNER INJECTOR HOLDER AND PILOT AIR INLET HOLE

The primary air inlet holes allow the proper amount of air to mix with the gas. This provides a clean burning flame. Keep these holes clear of dust, dirt, and lint. Clean these air inlet holes prior to each heating season. Blocked air holes will create soot. We recommend that you clean the unit every 2,500 hours of operation or every three months.

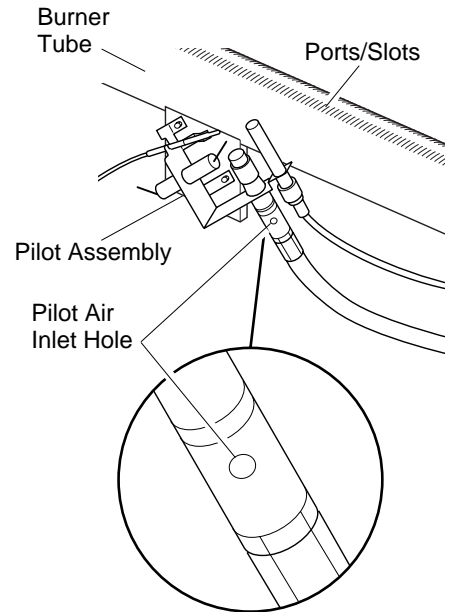
We also recommend that you keep the burner tube and pilot assembly clean and free of dust and dirt. To clean these parts we recommend using compressed air no greater than 30 PSI. Your local computer store, hardware store, or home center may carry compressed air in a can. You can use a vacuum cleaner in the blow position. If using compressed air in a can, please follow the directions on the can. If you don't follow directions on the can, you could damage the pilot assembly.

1. Shut off the unit, including the pilot. Allow the unit to cool for at least thirty minutes.
2. Inspect burner, pilot, and primary air inlet holes on injector holder for dust and dirt (see Figure 36).
3. Blow air through the ports/slots and holes in the burner.
4. Check the injector holder located at the end of the burner tube again. Remove any large particles of dust, dirt, lint, or pet hairs with a soft cloth or vacuum cleaner nozzle.
5. Blow air into the primary air holes on the injector holder.
6. In case any large clumps of dust have now been pushed into the burner repeat steps 3 and 4.

Clean the pilot assembly also. A yellow tip on the pilot flame indicates dust and dirt in the pilot assembly. There is a small pilot air inlet hole about two inches from where the pilot flame comes out of the pilot assembly (see Figure 37). With the unit off, lightly blow air through the air inlet hole. You may blow through a drinking straw if compressed air is not available.



**Figure 36 - Injector Holder On Outlet Burner Tube**



**Figure 37 - Pilot Inlet Air Hole**

### LOGS

- If you remove logs for cleaning, refer to *Installing Logs*, page 13, 14, or 15, to properly replace logs.
- Replace log(s) if broken or chipped (dime-sized or larger).

### BURNER PRIMARY AIR HOLES

Air is drawn into the burner through the 8 holes in the brass fitting at the entrance to the burner. These holes may become blocked with dust or lint. Periodically inspect these holes for any blockage and clean as necessary. Blocked air holes will create soot.

### MAIN BURNER

Periodically inspect all burner flame holes with the heater running. All slotted burner flame holes should be open with yellow flame present. All round burner flame holes should be open with a small blue flame present. Some burner flame holes may become blocked by debris or rust, with no flame present. If so, turn off heater and let cool. Either remove blockage or replace burner. Blocked burner flame holes will create soot.

**UNVENTED NATURAL GAS LOG HEATER**

**TROUBLESHOOTING**

*Note:* For additional help, visit DESA International's Technical Service web site at [www.desatech.com](http://www.desatech.com).

*Note:* All troubleshooting items are listed in order of operation.

**⚠ WARNING:** Turn off and unplug heater and let cool before servicing. Only a qualified service person should service and repair heater.

**⚠ CAUTION:** Never use a wire, needle, or similar object to clean ODS/pilot. This can damage ODS/pilot unit.

OBSERVED PROBLEM	POSSIBLE CAUSE	REMEDY
When ignitor button is pressed, there is no spark at ODS/pilot	<ol style="list-style-type: none"> <li>Ignitor electrode not connected to ignitor cable</li> <li>Ignitor cable pinched or wet</li> <li>Piezo ignitor nut is loose</li> <li>Broken ignitor cable</li> <li>Bad piezo ignitor</li> <li>Ignitor electrode broken</li> <li>Ignitor electrode positioned wrong</li> </ol>	<ol style="list-style-type: none"> <li>Reconnect ignitor cable</li> <li>Free ignitor cable if pinched by any metal or tubing. Keep ignitor cable dry</li> <li>Tighten nut holding piezo ignitor to base panel of log set. Nut is located behind base panel.</li> <li>Replace ignitor cable</li> <li>Replace piezo ignitor</li> <li>Replace piezo ignitor</li> <li>Replace piezo ignitor</li> </ol>
When ignitor button is pressed, there is spark at ODS/pilot but no ignition	<ol style="list-style-type: none"> <li>Gas supply turned off or manual shutoff valve closed</li> <li>Control knob not in PILOT position</li> <li>Control knob not pressed in while in PILOT position</li> <li>Air in gas lines when installed</li> <li>ODS/pilot is clogged</li> <li>Gas regulator setting is not correct</li> </ol>	<ol style="list-style-type: none"> <li>Turn on gas supply or open manual shutoff valve</li> <li>Turn control knob to PILOT position</li> <li>Press in control knob while in PILOT position</li> <li>Continue holding down control knob. Repeat igniting operation until air is removed</li> <li>Clean ODS/pilot (see <i>Cleaning and Maintenance</i>, page 19) or replace ODS/pilot assembly</li> <li>Replace gas regulator</li> </ol>
ODS/pilot lights but flame goes out when control knob is released	<ol style="list-style-type: none"> <li>Control knob not fully pressed in</li> <li>Control knob not pressed in long enough</li> <li>Manual shutoff valve not fully open</li> <li>Pilot flame not touching thermocouple, which allows thermocouple to cool, causing pilot flame to go out. This problem could be caused by one or both of the following:                             <ol style="list-style-type: none"> <li>Low gas pressure</li> <li>Dirty or partially clogged ODS/pilot</li> </ol> </li> <li>Thermocouple connection loose at control valve</li> <li>Thermocouple damaged</li> <li>Control valve damaged</li> </ol>	<ol style="list-style-type: none"> <li>Press in control knob fully</li> <li>After ODS/pilot lights, keep control knob pressed in 30 seconds</li> <li>Fully open manual shut-off valve</li> <li>                             A) Contact local natural gas company                               B) Clean ODS/pilot (see <i>Cleaning and Maintenance</i>, page 19) or replace ODS/pilot assembly                         </li> <li>Hand tighten until snug, then tighten 1/4 turn more</li> <li>Replace thermocouple</li> <li>Replace control valve</li> </ol>

# OWNER'S MANUAL

## TROUBLESHOOTING

*Continued*

OBSERVED PROBLEM	POSSIBLE CAUSE	REMEDY
Burner does light after ODS/pilot is lit	<ol style="list-style-type: none"><li>1. Burner orifice clogged</li><li>2. Inlet gas pressure is too low</li><li>3. Burner orifice diameter is too small</li></ol>	<ol style="list-style-type: none"><li>1. Clean burner (see <i>Cleaning and Maintenance</i>, page 19) or replace burner orifice</li><li>2. Contact local natural gas company</li><li>3. Replace burner orifice</li></ol>
Delayed ignition burner	<ol style="list-style-type: none"><li>1. Manifold pressure is too low</li><li>2. Burner orifice clogged</li></ol>	<ol style="list-style-type: none"><li>1. Contact local natural gas company</li><li>2. Clean burner (see <i>Cleaning and Maintenance</i>, page 19) or replace burner orifice</li></ol>
Burner backfiring during combustion	<ol style="list-style-type: none"><li>1. Burner orifice is clogged or damaged</li><li>2. Damaged burner</li><li>3. Gas regulator defective</li></ol>	<ol style="list-style-type: none"><li>1. Clean burner (see <i>Cleaning and Maintenance</i>, page 19) or replace burner orifice</li><li>2. Replace damaged burner</li><li>3. Replace gas regulator</li></ol>
Slight smoke or odor during initial operation	<ol style="list-style-type: none"><li>1. Not enough air</li><li>2. Gas regulator defective</li><li>3. Residues from manufacturing processes and logs curing</li></ol>	<ol style="list-style-type: none"><li>1. Check burner for dirt and debris. If found, clean burner (see <i>Cleaning and Maintenance</i>, page 19)</li><li>2. Replace gas regulator</li><li>3. Problem will stop after a few hours of operation</li></ol>
Moisture/condensation noticed on windows	<ol style="list-style-type: none"><li>1. Not enough combustion/ventilation air</li></ol>	<ol style="list-style-type: none"><li>1. Refer to <i>Air for Combustion and Ventilation</i> requirements (page 4)</li></ol>
Heater produces a whistling noise when burner is lit	<ol style="list-style-type: none"><li>1. Turning control knob to HI position when burner is cold</li><li>2. Air in gas line</li><li>3. Air passageways on heater blocked</li><li>4. Dirty or partially clogged burner orifice</li></ol>	<ol style="list-style-type: none"><li>1. Turn control knob to LO position and let warm up for a minute</li><li>2. Operate burner until air is removed from line. Have gas line checked by local natural gas company</li><li>3. Observe minimum installation clearances (see pages 7 through 9)</li><li>4. Clean burner (see <i>Cleaning and Maintenance</i>, page 19) or replace burner orifice</li></ol>
White powder residue forming within burner box or on adjacent walls or furniture	<ol style="list-style-type: none"><li>1. When heated, vapors from furniture polish, wax, carpet cleaners, etc. turn into white powder residue</li></ol>	<ol style="list-style-type: none"><li>1. Turn heater off when using furniture polish, wax, carpet cleaners, or similar products</li></ol>

**UNVENTED NATURAL GAS LOG HEATER**

**TROUBLESHOOTING**

*Continued*

- ⚠ WARNING: If you smell gas**
- Shut off gas supply.
  - Do not try to light any appliance.
  - Do not touch any electrical switch; do not use any phone in your building.
  - Immediately call your gas supplier from a neighbor’s phone. Follow the gas supplier’s instructions.
  - If you cannot reach your gas supplier, call the fire department.

*IMPORTANT:* Operating heater where impurities in air exist may create odors. Cleaning supplies, paint, paint remover, cigarette smoke, cements and glues, new carpet or textiles, etc., create fumes. These fumes may mix with combustion air and create odors. These odors will disappear over time.

OBSERVED PROBLEM	POSSIBLE CAUSE	REMEDY
Heater produces a clicking/ticking noise just after burner is lit or shut off	1. Metal expanding while heating or contracting while cooling	1. This is common with most heaters. If noise is excessive, contact qualified service person
Heater produces unwanted odors	1. Heater burning vapors from paint, hair spray, glues, cleaners, chemicals, new carpet, etc. (See <i>IMPORTANT</i> statement above) 2. Gas leak. <b>See Warning statement at top of page</b>	1. Open window and ventilate room. Stop using odor causing products while heater is running 2. Locate and correct all leaks (see <i>Checking Gas Connections</i> , page 12)
Heater shuts off in use (ODS operates)	1. Not enough fresh air is available 2. Low line pressure 3. ODS/pilot is partially clogged	1. Open window and/or door for ventilation 2. Contact local natural gas company 3. Clean ODS/pilot (see <i>Cleaning and Maintenance</i> , page 19)
Gas odor even when control knob is in OFF position	1. Gas leak. <b>See Warning statement at top of page</b> 2. Control valve defective	1. Locate and correct all leaks (see <i>Checking Gas Connections</i> , page 12) 2. Replace control valve
Gas odor during combustion	1. Foreign matter between control valve and burner 2. Gas leak. <b>See Warning statement at top of page</b>	1. Take apart gas tubing and remove foreign matter 2. Locate and correct all leaks (see <i>Checking Gas Connections</i> , page 12)
Log set cycles to pilot, but room temperature drops to a lower than ideal level before log set comes back on	1. Thermostat sensing bulb needs to be repositioned	1. Reposition thermostat sensing bulb (see <i>Optional Positioning of Thermostat Sensing Bulb</i> , page 23)

## OPTIONAL POSITIONING OF THERMOSTAT SENSING BULB

### For Masonry and Factory-built Metal Fireplace

If your log set cycles to pilot, but the room temperature drops to a lower than ideal comfort level before the log set comes back on, you may want to reposition the thermostat sensing bulb.

The thermostat sensing bulb is located near the gas valve assembly on the mounting bracket. This location allows the thermostat to keep the room temperature at an ideal comfort level for most fireplace applications. For positioning the thermostat sensing bulb elsewhere, an adhesive-backed mounting clip is available.

Tools needed: 1/4" hex driver or socket

1. Remove logs. Locate the gas valve assembly and thermostat sensing bulb (see Figure 38).
2. With 1/4" hex driver or socket, loosen the thermostat screw. Carefully slide the thermostat sensing bulb out of the retaining clamp (see Figure 40).

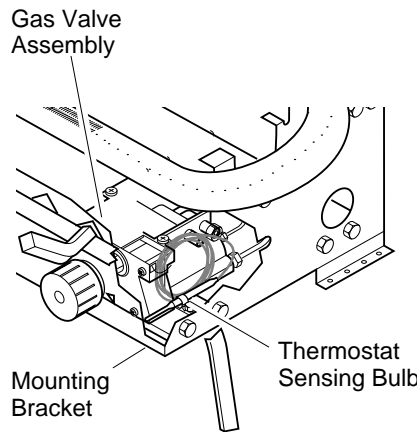
**Note:** Do not remove the screw. Make sure you tighten the screw after removing the thermostat sensing bulb.

**IMPORTANT:** Do not force or bend the thermostat sensing bulb or capillary.

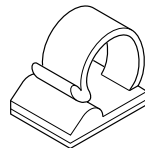
3. The thermostat sensing bulb may be located to the lower right front side of fireplace. Determine location of sensing bulb, but do not mount sensing bulb until step 5. If you have a masonry fireplace, see Figure 41 for location. If you have a factory-built metal fireplace, see Figure 42 for location. If your fireplace has glass doors, position sensing bulb directly behind door gap on right bottom side (see Figure 43).

4. The mounting clip must be a minimum of 3" from bottom of fireplace to prevent crimping of capillary. Once you have decided on a location, clean the area thoroughly. Remove the paper backing from the adhesive on back of mounting clip. Press the clip into the new location so that the thermostat sensing bulb will be positioned vertically with the capillary at the bottom (see Figure 44). Slide the thermostat sensing bulb into the clip.

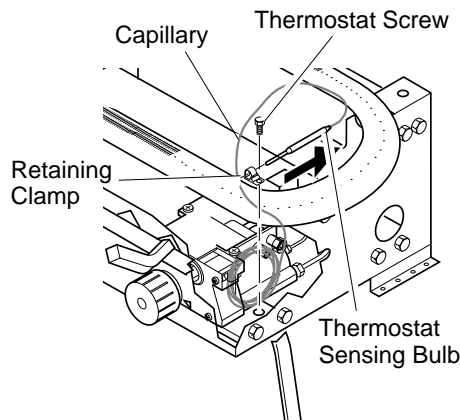
**IMPORTANT:** Do not crimp capillary.



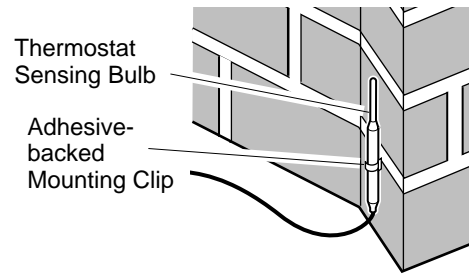
**Figure 38 - Location of Gas Valve Assembly and Thermostat Sensing Bulb**



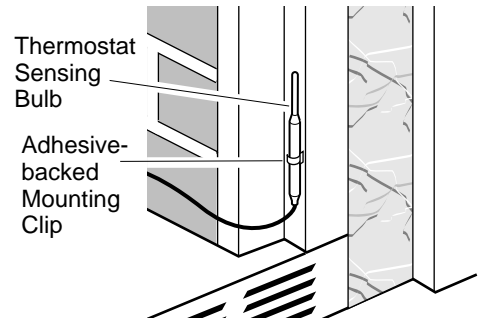
**Figure 39 - Adhesive-backed Mounting Clip**



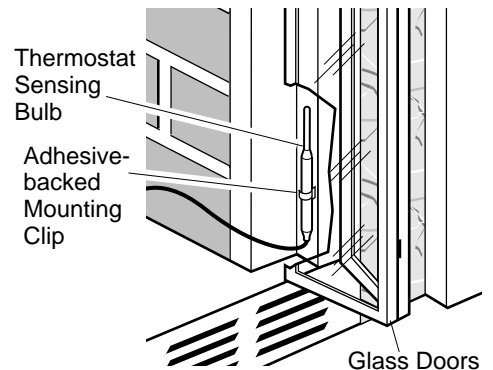
**Figure 40 - Removing Thermostat Sensing Bulb**



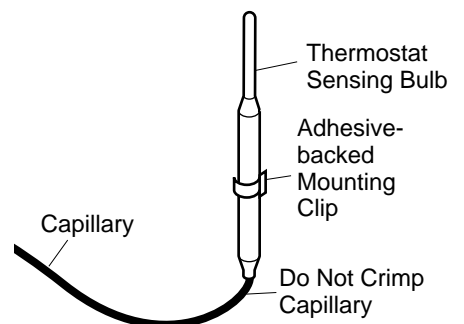
**Figure 41 - Locating Thermostat Sensing Bulb on Masonry Fireplace**



**Figure 42 - Locating Thermostat Sensing Bulb on Factory-built Metal Fireplace**



**Figure 43 - Installing Thermostat Sensing Bulb behind Glass Doors**



**Figure 44 - Positioning the Thermostat Sensing Bulb in the Vertical Position with the Capillary at the Bottom**



# CGS2718N, CGS3124N, CLD3018N, CLD3924NT, and CCL3930NT(A)

## UNVENTED NATURAL GAS LOG HEATER

### SPECIFICATIONS

	18" Model (CGS2718N)	18" Model (CLD3018N)	24" Model (CGS3124N)	24" Model (CLD3924NT)	30" Model (CCL3930NT(A))
Btu (Variable)	16,000/27,000	16,000/30,000	16,000/31,500	20,000/39,000	20,000/39,000
Type Gas	Natural Gas Only	Natural Gas Only	Natural Gas Only	Natural Gas Only	Natural Gas Only
Ignition	Piezo	Piezo	Piezo	Piezo	Piezo
Manifold Pressure	3.5" W.C.	3.5" W.C.	3.5" W.C.	3.5" W.C.	3.5" W.C.
Inlet Gas Pressure (in. of water)					
Maximum	10.5"	10.5"	10.5"	10.5"	10.5"
Minimum*	5"	5"	5"	5"	5"
Shipping Weight	27 lbs.	27 lbs.	29 lbs.	29lbs	70 lbs

\* For the purpose of input adjustment

### TECHNICAL SERVICE

You may have further questions about installation, operation, or troubleshooting. If so, contact DESA International's Technical Service Department at 1-800-DESA LOG (1-800-337-2564).

You can also visit DESA International's Technical Service web site at [www.desatech.com](http://www.desatech.com).

### SERVICE HINTS

#### When Gas Pressure Is Too Low

- pilot will not stay lit
- burners will have delayed ignition
- heater will not produce specified heat

#### When Gas Quality Is Bad

- pilot will not stay lit
- burners will produce flames and soot
- heater will backfire when lit

You may feel your gas pressure is too low or gas quality is bad. If so, contact your local natural gas supplier.

### REPLACEMENT PARTS

*Note:* Use only original replacement parts. This will protect your warranty coverage for parts replaced under warranty.

#### PARTS UNDER WARRANTY

Contact authorized dealers of this product. If they can't supply original replacement part(s), call DESA International's Technical Service Department at 1-800-DESA-LOG (1-800-337-2564).

When calling DESA International, have ready

- your name
- your address
- model and serial numbers of your heater
- how heater was malfunctioning
- type of gas used (propane/LP or natural gas)
- purchase date

Usually, we will ask you to return the defec-

tive part to the factory.

#### PARTS NOT UNDER WARRANTY

Contact authorized dealers of this product. If they can't supply original replacement part(s), call DESA International's Parts Department at 1-800-972-7879 for referral information.

When calling DESA International, have ready

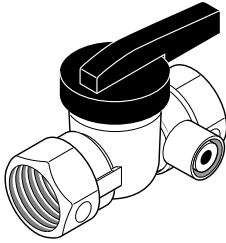
- model number of your heater
- the replacement part number



# OWNER'S MANUAL

## ACCESSORIES

Purchase these fireplace accessories from your local dealer. If they can not supply these accessories, either contact your nearest Parts Central or call DESA International's Sales Department at 1-800-458-2472 for information. You can also write to the address listed on the back page of this manual.

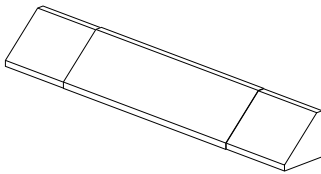


### MANUAL SHUTOFF VALVE - GA5010

For all models. Manual shutoff valve with 1/8" NPT tap. Fits 1/2" NPT pipe.

### DAMPER CLAMP - GA6080 (Not Shown)

For variably-controlled models. Permanently opens chimney flue damper for vented operation.



### FIREPLACE HOOD

**Black - GA6050**

**Brass - GA6052**

**Antique Brass - GA6053**

For all models. Helps deflect heat away from mantel or wall above fireplace.

### LAVA ROCK - GA6060 (Not Shown)

For all models. Order when additional rock is desired. (3 lb. bag)

## PARTS CENTRAL

These Parts Centrals are privately owned businesses. They have agreed to support our customer's needs by providing original replacement parts and accessories.

### Baltimore Electric

1348 Dixwell Avenue  
Hamden, CT 06514  
1-800-397-7553  
203-248-7553  
Parts Department

### Portable Heater Parts

342 N. County Rd. 400 East  
Valparaiso, IN 46383  
All States  
219-462-7441  
1-800-362-6951

### FBD

1349 Adams Street  
Bowling Green, KY 42103  
(502) 846-1199  
1-800-654-8534  
Fax: 1-800-846-0090

### Four Flags Power Products

1115 Stateline Road  
Niles, MI 49120  
1-800-268-4983  
616-684-2697  
Parts Only

### Master Service Center

1184 Wilson Ave. N W  
Grand Rapids, MI 49504-3458  
616-791-8270  
1-800-446-1446

### Washer Equipment Co.

1715 Main Street  
Kansas City, MO 64108  
KS, MO, AR  
816-842-3911

### East Coast Energy

Products  
707 Broadway  
W. Long Branch, NJ 07764  
732-870-8809  
1-800-755-8809

### Tarantin Tank Co.

P.O. Box 6129  
Freehold, NJ 07728  
908-780-9340  
1-800-922-0724

### Dayton Hardware

P.O. Box 275  
North Dayton Station  
Dayton, OH 45404  
All States  
937-258-3721  
OH 1-800-762-3426

### Halco Enterprises

208 Carter Drive, Unit 21  
West Chester, PA 19382  
610-430-7717  
1-800-368-0803

### LA Porte's Parts & Service

2444 N. 5th Street  
Hartsville, SC 29550  
803-332-0191  
Parts Department

### Cans Unlimited, Inc.

P.O. Box 645  
Taylor, SC 29687  
All States  
803-879-3009  
1-800-845-5301

### Heater & Fireplace Store

1922 N Route 9  
Cape May Court, NJ 08210-1110  
609-624-0678  
Parts Department

*Comfort Glow*®

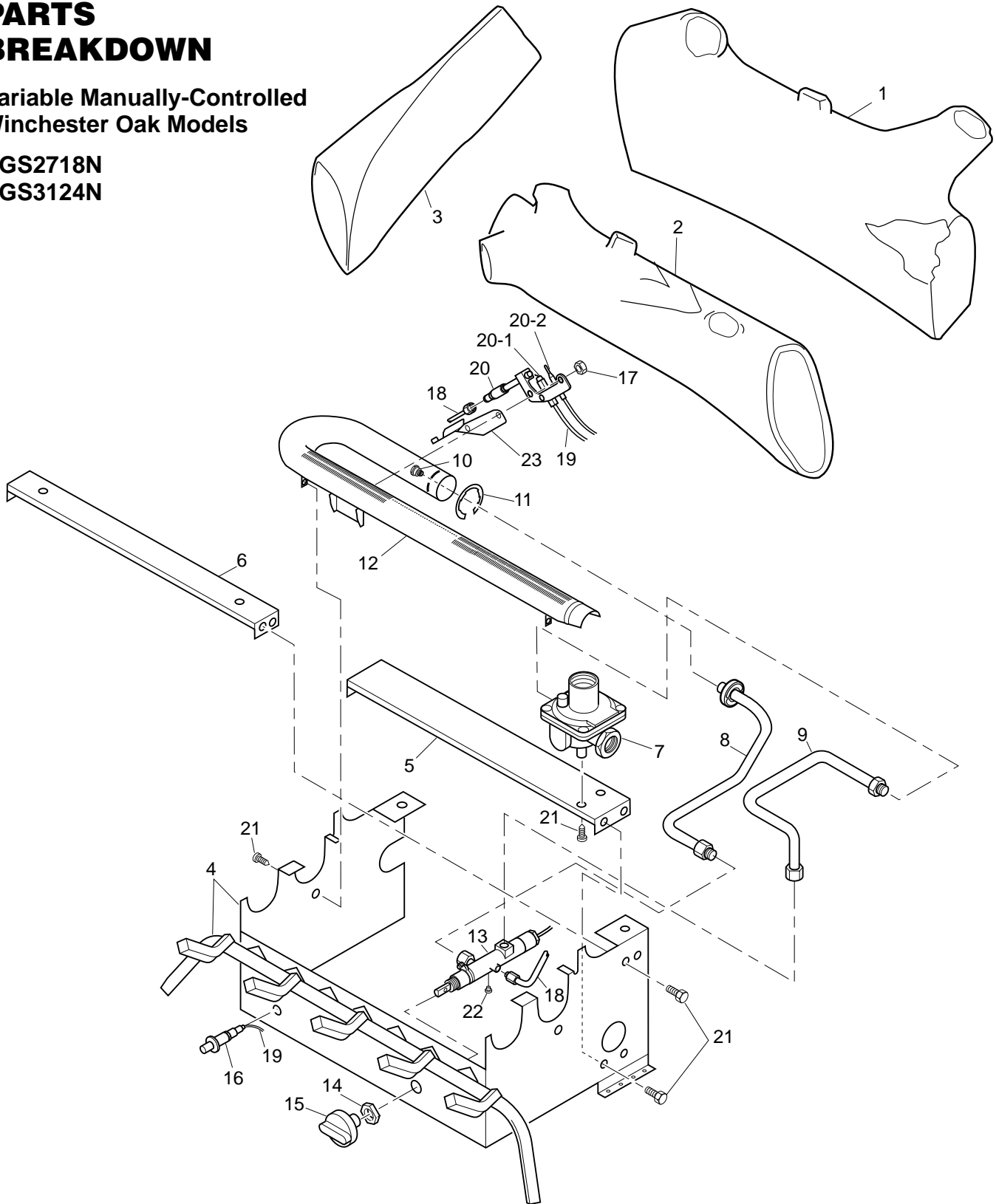
**CGS2718N, CGS3124N, CLD3018N,  
CLD3924NT, and CCL3930NT(A)**

# UNVENTED NATURAL GAS LOG HEATER

## ILLUSTRATED PARTS BREAKDOWN

Variable Manually-Controlled  
Winchester Oak Models

CGS2718N  
CGS3124N



# OWNER'S MANUAL

## PARTS LIST

This list contains replaceable parts used in your heater. When ordering parts, follow the instructions listed under *Replacement Parts* on page 24 of this manual.

### Variable Manually-Controlled Winchester Oak Models

CGS2718N  
CGS3124N

KEY NO.	CGS2718N PART NUMBER	CGS3124N PART NUMBER	DESCRIPTION	QTY.
1	103729-02	103729-01	Back Log (#1)	1
2	103730-02	103730-01	Front Log (#2)	1
3	103731-02	103731-01	Crossover Log (#3)	1
4	102775-02CK	102775-01CK	Painted Base Assembly	1
5	102844-01	102844-01	Lower Bracket	1
6	102966-01	102966-01	Upper Bracket	1
7	098867-11	098867-11	Gas Regulator	1
8	102780-01	102780-01	Outlet Burner Tube	1
9	102798-01	102798-01	Inlet Tube	1
10	099056-20	099056-18	Burner Orifice Injector	1
11	102843-01	102843-01	Burner Clip	1
12	102963-01	102773-01	Burner	1
13	102568-07	102568-07	Control Valve	1
14	098508-01	098508-01	Valve Retainer Nut	1
15	098354-01	098354-01	Control Knob	1
16	102445-01	102445-01	Piezo Ignitor	1
17	098249-01	098249-01	Nut, M5	2
18	099387-08	099387-08	Pilot Tube	1
19	098271-07	098271-07	Ignitor Cable	1
20	103042-01	103042-01	ODS Pilot	1
20-1	098594-01	098594-01	Ignitor Electrode	1
20-2	098593-01	098593-01	Thermocouple	1
21	M11084-38	M11084-38	Screw, Hex Head (#8-18 x .38)	11
22	098276-01	098276-01	Hex Head Plug, 1/8" NPT	1
23	099553-01	099553-01	Shield, Pilot	1
<b>PARTS AVAILABLE — NOT SHOWN</b>				
	100563-01	100563-01	Warning Plate	1
	101055-02	101055-02	Lighting Instructions Plate	1
	100565-01	100565-01	Warning Plate Fastener	1
	100639-01	100639-01	Caution Decal	1
	101449-04	101449-04	Control Position Decal	1
	101137-02	101137-02	Hardware Kit	1
	101416-40	101416-40	Information Video	1
	GA6060	GA6060	Lava Rock	1

*Comfort Glow*®

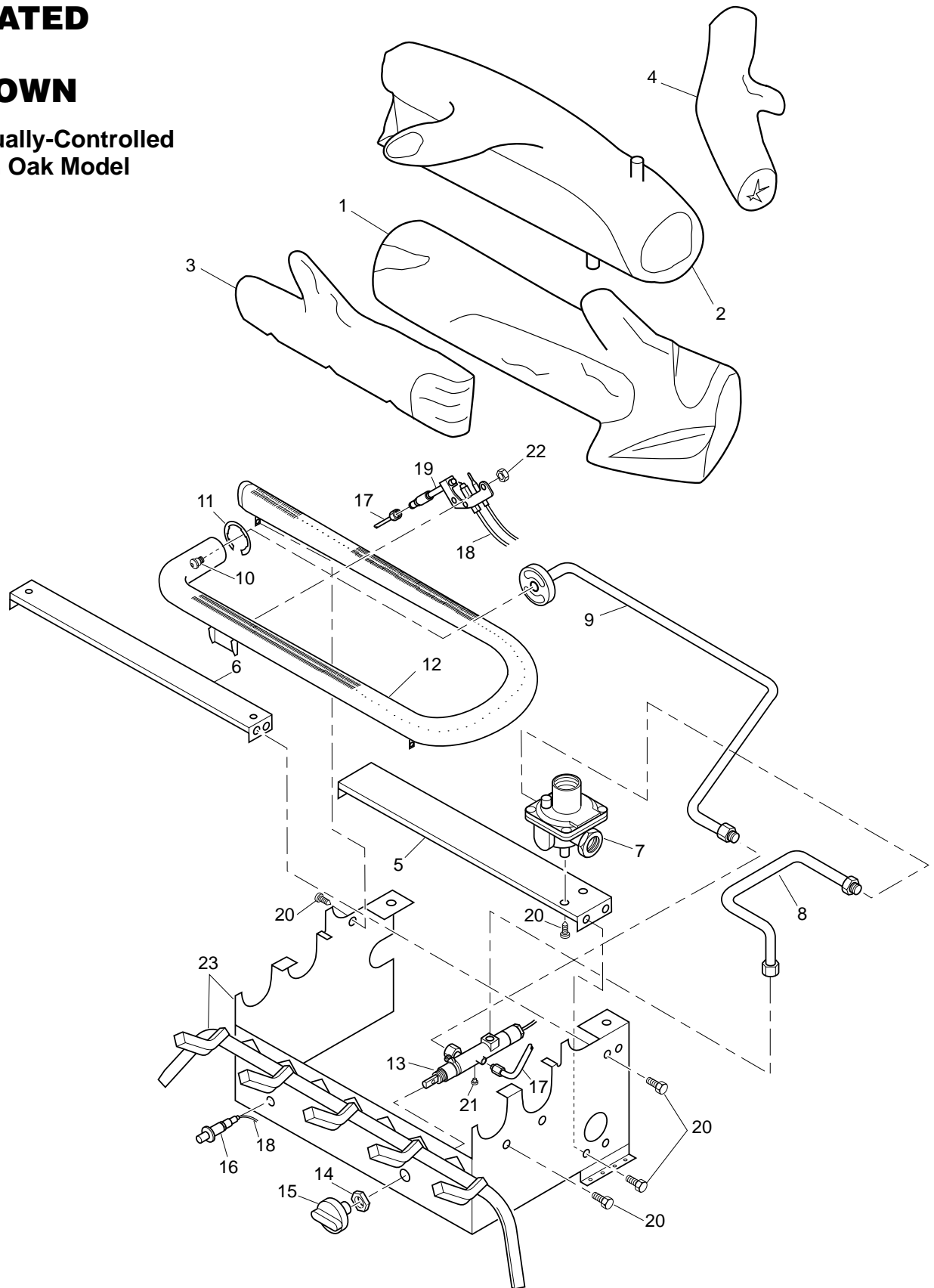
**CGS2718N, CGS3124N, CLD3018N,  
CLD3924NT, and CCL3930NT(A)**

# UNVENTED NATURAL GAS LOG HEATER

## ILLUSTRATED PARTS BREAKDOWN

Variable Manually-Controlled  
Royal English Oak Model

CLD3018N



# OWNER'S MANUAL

## PARTS LIST

This list contains replaceable parts used in your heater. When ordering parts, follow the instructions listed under *Replacement Parts* on page 24 of this manual.

### Variable Manually-Controlled Royal English Oak Model

#### CLD3018N

KEY NO.	CLD3018N PART NUMBER	DESCRIPTION	QTY.
1	104933-01	Middle Log (#1)	1
2	104934-01	Back Log (#2)	1
3	104932-01	Front Log (#3)	1
4	104935-01	Crossover Log (#4)	1
5	102844-02	Lower Bracket	1
6	102966-02	Upper Bracket	1
7	098867-11	Gas Regulator	1
8	102798-01	Inlet Tube	1
9	102779-03	Outlet Burner Tube	1
10	099056-26	Burner Orifice Injector	1
11	102843-01	Burner Clip	1
12	102980-01	Burner	1
13	102568-07	Control Valve	1
14	098508-01	Valve Retainer Nut	1
15	098354-01	Control Knob	1
16	102445-01	Piezo Ignitor	1
17	099387-08	Pilot Tube	1
18	098271-07	Ignitor Cable	1
19	104285-01	ODS Pilot	1
20	M11084-38	Screw, Hex Head (#8-18 x .38)	11
21	098276-01	Hex Head Plug, 1/8" NPT	1
22	098249-01	Nut, M5	2
23	102775-04CK	Painted Base Assembly	1
<b>PARTS AVAILABLE — NOT SHOWN</b>			
	100563-01	Warning Plate	1
	101055-02	Lighting Instructions Plate	1
	100565-01	Warning Plate Fastener	1
	100639-01	Caution Decal	1
	101449-04	Control Position Decal	1
	101137-02	Hardware Kit	1
	101416-40	Information Video	1
	GA6060	Lava Rock	1

*Comfort Glow*®

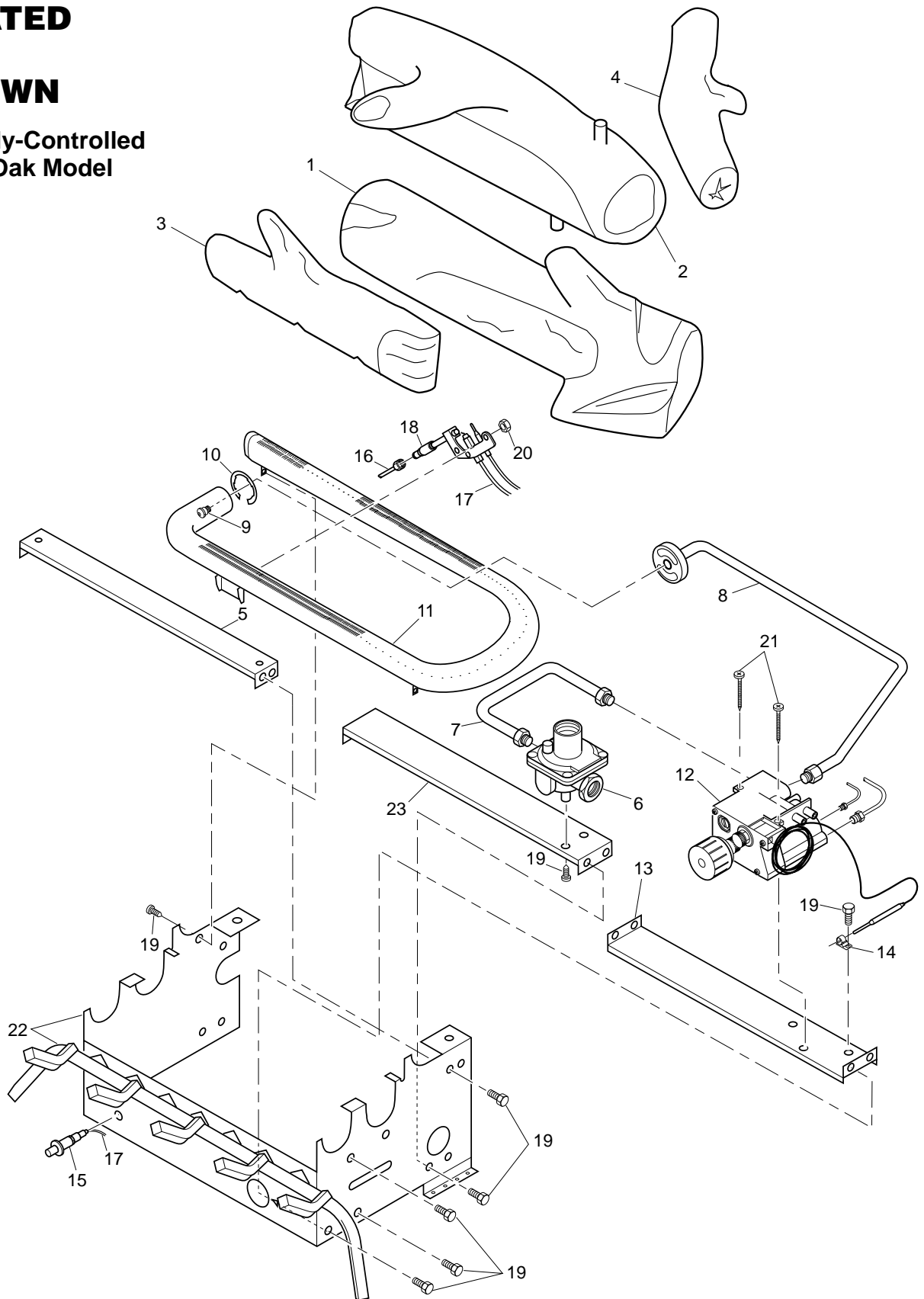
**CGS2718N, CGS3124N, CLD3018N,  
CLD3924NT, and CCL3930NT(A)**

# UNVENTED NATURAL GAS LOG HEATER

## ILLUSTRATED PARTS BREAKDOWN

Thermostatically-Controlled  
Royal English Oak Model

CLD3924NT



# OWNER'S MANUAL

## PARTS LIST

This list contains replaceable parts used in your heater. When ordering parts, follow the instructions listed under *Replacement Parts* on page 24 of this manual.

### Thermostatically-Controlled Royal English Oak Model

#### CLD3924NT

KEY NO.	CLD3924NT PART NUMBER	DESCRIPTION	QTY.
1	104937-01	Middle Log (#1)	1
2	104938-01	Rear Log (#2)	1
3	104936-01	Front Log (#3)	1
4	104939-01	Crossover Log (#4)	1
5	102966-01	Upper Bracket	1
6	098867-11	Gas Regulator	1
7	102981-01	Inlet Tube	1
8	102983-01	Outlet Burner Tube	1
9	099056-16	Burner Orifice Injector	1
10	102843-01	Burner Clip	1
11	102772-01	Burner	1
12	101329-20	Thermostat Gas Valve Assembly	1
13	102979-01	Thermostat Bracket	1
14	098544-01	Thermobulb Clip	1
15	102445-01	Piezo Ignitor	1
16	099387-09	Pilot Tube	1
17	098271-07	Ignitor Cable	1
18	104285-01	ODS Pilot	1
19	M11084-38	Hex Screw, #8-18 x .38	15
20	098249-01	Nut, M5	2
21	099211-01	Hex Screw, 10-16 x 2.50	2
22	102775-05CK	Painted Base Assembly	1
23	102844-01	Lower Bracket	1
<b>PARTS AVAILABLE — NOT SHOWN</b>			
	100563-01	Warning Plate	1
	101054-01	Lighting Instructions Plate	1
	100565-01	Warning Plate Fastener	1
	100639-01	Caution Decal	1
	101137-02	Hardware Kit	1
	101416-40	Information Video	1
	GA6060	Lava Rock	1

*Comfort Glow*®

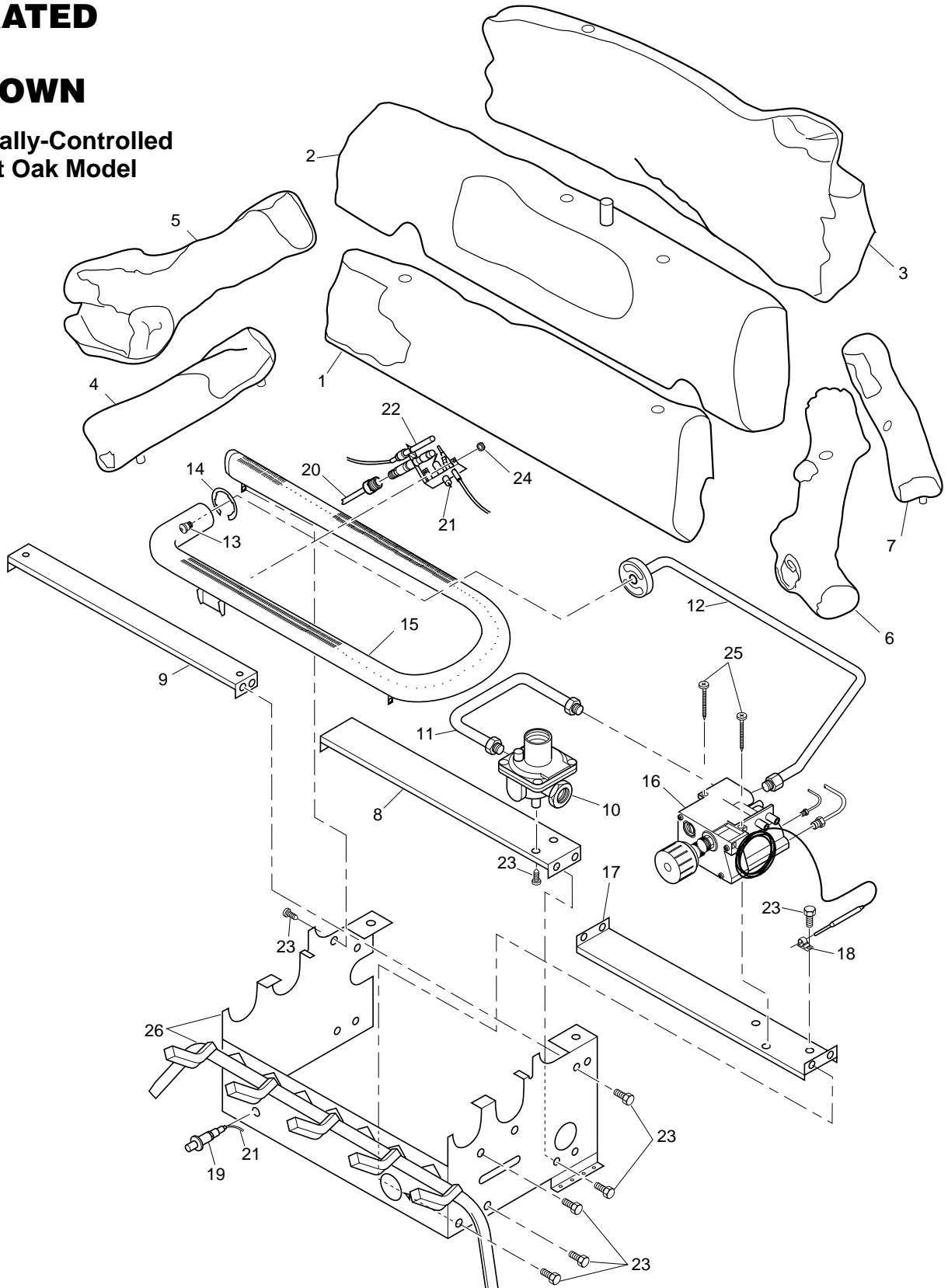
**CGS2718N, CGS3124N, CLD3018N,  
CLD3924NT, and CCL3930NT(A)**

# UNVENTED NATURAL GAS LOG HEATER

## ILLUSTRATED PARTS BREAKDOWN

Thermostatically-Controlled  
Biltmore Split Oak Model

CCL3930NT  
CCL3930NTA





# OWNER'S MANUAL

## PARTS LIST

This list contains replaceable parts used in your heater. When ordering parts, follow the instructions listed under *Replacement Parts* on page 24 of this manual.

### Thermostatically-Controlled Biltmore Split Oak Model

#### CCL3930NT CCL3930NTA

KEY NO.	CCL3930NT PART NUMBER	CCL3930NTA PART NUMBER	DESCRIPTION	QTY.
1	105923-01	105923-02	Front Log (#1)	1
2	105924-01	105924-02	Middle Log (#2)	1
3	105925-01	105925-02	Back Log (#3)	1
4	105926-01	105926-02	Left Back Crossover Log (#4)	1
5	105927-01	105927-02	Left Top Crossover Log (#5)	1
6	105928-01	105928-02	Right Bottom Crossover Log (#6)	1
7	105929-01	105929-02	Right Top Crossover Log (#7)	1
8	102844-01	102844-01	Lower Bracket	1
9	102966-01	102966-01	Upper Bracket	1
10	098867-14	098867-14	Gas Regulator	1
11	102981-01	102981-01	Inlet Tube	1
12	102983-01	102983-01	Outlet Burner Tube	1
13	099056-16	099056-16	Burner Orifice Injector	1
14	102843-01	102843-01	Burner Clip	1
15	102772-01	102772-01	Burner	1
16	101329-20	101329-20	Thermostat Gas Valve Assembly	1
17	102979-01	102979-01	Thermostat Bracket	1
18	098544-01	098544-01	Thermobulb Clip	1
19	102445-01	102445-01	Piezo Ignitor	1
20	099387-09	099387-09	Pilot Tube	1
21	098271-07	098271-07	Ignitor Cable	1
22	104285-01	104285-01	ODS Pilot	1
23	M11084-38	M11084-38	Hex Screw, #8-18 x .38	15
24	098249-01	098249-01	Nut, M5	2
25	099211-01	099211-01	Hex Screw, 10-16 x 2.50	2
26	102775-07CK	102775-07CK	Painted Base Assembly	1
<b>PARTS AVAILABLE — NOT SHOWN</b>				
	100563-01	100563-01	Warning Plate	1
	101054-01	101054-01	Lighting Instructions Plate	1
	100565-01	100565-01	Warning Plate Fastener	1
	100639-01	100639-01	Caution Decal	1
	101137-02	101137-02	Hardware Kit	1
	101416-40	101416-40	Information Video	1
	GA6060	GA6060	Lava Rock	1
	102030-01	102030-01	Clip, Thermostat	1

# WARRANTY INFORMATION

## KEEP THIS WARRANTY

Model _____
Serial No. _____
Date Purchased _____

Always specify model and serial numbers when communicating with the factory.

We reserve the right to amend these specifications at any time without notice. The only warranty applicable is our standard written warranty. We make no other warranty, expressed or implied.

### LIMITED WARRANTY COMFORT GLOW VENT-FREE NATURAL GAS LOG HEATERS

DESA International warrants this product to be free from defects in materials and components for two (2) years from the date of first purchase, provided that the product has been properly installed, operated and maintained in accordance with all applicable instructions. To make a claim under this warranty the Bill of Sale or cancelled check must be presented.

This warranty is extended only to the original retail purchaser. This warranty covers the cost of part(s) required to restore this heater to proper operating condition and an allowance for labor when provided by a DESA Authorized Service Center. Warranty part(s) MUST be obtained through authorized dealers of this product and/or DESA International who will provide original factory replacement parts. Failure to use original factory replacement parts voids this warranty. The heater MUST be installed by a qualified installer in accordance with all local codes and instructions furnished with the unit.

This warranty does not apply to parts that are not in original condition because of normal wear and tear, or parts that fail or become damaged as a result of misuse, accidents, lack of proper maintenance or defects caused by improper installation. Travel, diagnostic cost, labor, transportation and any and all such other costs related to repairing a defective heater will be the responsibility of the owner.

TO THE FULL EXTENT ALLOWED BY THE LAW OF THE JURISDICTION THAT GOVERNS THE SALE OF THE PRODUCT; THIS EXPRESS WARRANTY EXCLUDES ANY AND ALL OTHER EXPRESSED WARRANTIES AND LIMITS THE DURATION OF ANY AND ALL IMPLIED WARRANTIES, INCLUDING WARRANTIES OF MERCHANTABILITY AND FITNESS FOR A PARTICULAR PURPOSE TO TWO (2) YEARS ON ALL COMPONENTS FROM THE DATE OF FIRST PURCHASE; AND DESA INTERNATIONAL'S LIABILITY IS HEREBY LIMITED TO THE PURCHASE PRICE OF THE PRODUCT AND DESA INTERNATIONAL SHALL NOT BE LIABLE FOR ANY OTHER DAMAGES WHATSOEVER INCLUDING INDIRECT, INCIDENTAL OR CONSEQUENTIAL DAMAGES.

Some states do not allow a limitation on how long an implied warranty lasts or an exclusion or limitation of incidental or consequential damages, so the above limitation on implied warranties, or exclusion or limitation on damages may not apply to you.

This warranty gives you specific legal rights, and you may also have other rights that vary from state to state.

For information about this warranty write:

**DESA**  
**INTERNATIONAL**

2701 Industrial Drive  
P.O. Box 90004  
Bowling Green, KY 42102-9004  
www.desatech.com



104385 01

NOT A UPC

104385-01  
Rev. D  
10/99