

# ProComp Infiniti<sup>™</sup>

## Hardware Manual



### *Thought Technology Ltd.*

2180 Belgrave Avenue, Montreal, QC H4A 2L8 Canada

Tel: (800) 361-3651 • (514) 489-8251 Fax: (514) 489-8255

E-mail: [mail@thoughttechnology.com](mailto:mail@thoughttechnology.com)

Webpage: <http://www.thoughttechnology.com>



0413

<b>The Manufacturer:</b>	Thought Technology Ltd. 2180 Belgrave Avenue Montreal, Quebec, Canada H4A 2L8
<b>System Name:</b>	ProComp Infiniti System
<b>System #:</b>	T7110M, T7120M, T7150M, T7160M, T7170M, T7520M
<b>Device Name:</b>	ProComp Infiniti Encoder
<b>Device #:</b>	SA7500
<b>Classification:</b>	Class 1 with a Measuring Function
<b>Rule(s) used for classification:</b>	Annex IX, rule 12
<b>Notified Body:</b>	SEMKO (0413)



### CAUTION

- Type BF Equipment
- Internally powered equipment
- Continuous operation
- Read Instruction Manual

- US Federal Law restricts this device to sale by, or on order of, a physician or any other practitioner licensed by the law of the state in which he or she practices to use or order the use of this device.

### WARNING

- Do not operate Active Sensors within 10 feet of an operating cellular phone, similar radio transmitting device, other powerful radio interference producing sources such as arc welders, radio thermal treatment equipment, x-ray machines, or any other equipment that produces electrical sparks.
- All encoders are totally isolated from line (110 or 220VAC) power due to battery operation and fiber optic connections to computers. However, many hospitals and the FDA require that computers, printers and any other equipment used with medical devices be electrically isolated from line voltage to UL or CSA medical safety standards.
- The PC used with ProComp Infiniti must be placed outside the patient/client environment (more than 3 meters or 10 feet) or the PC must comply with EN60601-1 (system safety).
- After use, the Disposable Electrodes may be a biohazard. Handle, and when applicable, dispose of these materials in accordance with accepted medical practice and any applicable local, state and federal laws and regulations.
- Reusable electrodes present a potential risk of cross-infection especially when used on abraded skin, unless they are restricted to a single patient or sterilized between patients. If sterilizing electrodes, employ only gas sterilization.
- Radiated radio frequency electromagnetic fields can cause performance degradation in the MyoScan-Pro EMG sensor. In the worst case, an RF field strength of 22mV/M can cause an increase of 1 $\mu$ V in the signal reading from a MyoScan-Pro sensor. Be sure to keep in mind that a very relaxed muscle should provide an EMG reading of approximately 1-3 $\mu$ V.
- Explosion Hazard; Do not use in the presence of a flammable anesthetic mixture with air, or with Oxygen or Nitrous Oxide.
- Not to be immersed in water.
- Take care in arranging patient and sensor cables to avoid risk of patient entanglement or strangulation.
- The operator is responsible for ensuring the safety of any devices controlled or triggered by Infiniti equipment or software, or by any software or hardware receiving data from Infiniti equipment. Infiniti equipment must not be configured or connected in such a way that failure in its data acquisition, processing or control functions can trigger patient feedback stimulus that poses an unacceptable level of risk.
- Use of any equipment in a biofeedback context should be immediately terminated upon any sign of treatment-related distress or discomfort.
- Not to be connected to a patient undergoing MRI, Electro surgery or defibrillation.

### ATTENTION

- Sensors damaged by static electricity are not covered under warranty. To prevent static discharge from damaging the sensor and/or encoders, use anti-static mats or sprays in your working area. A humidifier may also be used to prevent static environments by conditioning hot, dry air.
- Do not apply any electrode gel or equivalent directly on the sensor snaps. Always use electrodes as a medium between the sensor and the client.
- Not for diagnostic purposes, not defibrillator proof, not for critical patient monitoring.
- To prevent voiding warranty by breaking connector pins, carefully align white guiding dot on sensor plug with slot on sensor input.
- Sharp bends or winding the fiber optic cable in a loop smaller than 4 inches (10cm) may destroy the cable.
- A fiber optic cable not fully pushed into its receptacle may cause the unit not to operate; make sure that both ends of the cable are fully inserted into their receptive jacks and the nut is tightened firmly.
- Make sure to remove electrodes from sensor snaps immediately after use.
- Do not plug third party sensors directly into instrument inputs. Plug only Thought Technology

Active Sensor cable connectors into instrument inputs. All electrodes and third party sensors must be connected to active sensors, either directly or through an adapter.

- Remove batteries when the device is not being used for an extended period of time. Please dispose of battery following local regulations.

## CONTRAINDICATIONS

- None

## INTENDED PURPOSE

- Biofeedback, Relaxation & Muscle Re-Education purposes.

## NOTE

- No preventative inspections required; maintenance must be performed by qualified personnel.
- The supplier will make available, upon request, circuit diagrams, component parts lists and description or other information required for the repair of product by qualified personnel.
- If a fiber optic or patient cable is damaged or breaks please replace.
- Due to the essential performance and intended use of the device, testing for immunity to electromagnetic disturbances was not required and was not performed. The device may be susceptible at levels below IEC60601-1-2 immunity test levels.
- The operator must be familiar with typical characteristics of signals acquired by this equipment, and be able to detect anomalies in the acquired signal that could interfere with treatment effectiveness. Depending on the importance of signal integrity, it may be advisable to continuously monitor the raw signals, in time and/or frequency domain, while the device is being used for biofeedback or other purposes. If anomalies are observed on acquired signals, and if you suspect a problem with electromagnetic interference, contact Thought Technology for a technical note on identification and remediation.

## MAINTENANCE AND CALIBRATION

- Wipe encoder with a clean cloth
- Factory testing and calibration ensure equipment accuracy and frequency response. The user may invoke a self-calibration function that will recalibrate certain device parameters (see section in manual). Contact Thought Technology for factory re-calibration if necessary.

## STORAGE

- Store in its original case at up to 90% humidity / 30C°

## TRANSPORTATION

- Transport in its original case

<b>Guidance and manufacturer's declaration – electromagnetic emissions</b>		
The Infiniti system is intended for use in the electromagnetic environment specified below. The customer or the user of the Infiniti system should assure that it is used in such an environment.		
<b>Emissions test</b>	<b>Compliance</b>	<b>Electromagnetic environment – guidance</b>
RF emissions CISPR 11	Group 1	The Infiniti system uses RF energy only for its internal function. Therefore, its RF emissions are very low and are not likely to cause any interference in nearby electronic equipment.  The Infiniti system is suitable for use in all establishments, including domestic establishments and those directly connected to the public low-voltage power supply network that supplies buildings used for domestic purposes.
RF emissions CISPR 11	Class B	
Harmonic emissions IEC 61000-3-2	Not applicable	
Voltage fluctuations/ flicker emissions IEC 61000-3-3	Not applicable	

# TABLE OF CONTENTS

<b>INTRODUCTION</b> .....	<b>7</b>
<b>CONNECTING THE ENCODER, TT-USB AND SENSORS</b> .....	<b>8</b>
SETTING UP THE ENCODER UNIT .....	8
ENCODER DIP SWITCH SETUP .....	9
<i>Battery Placement</i> .....	10
COMPACT FLASH .....	10
<i>Compact Flash Setup</i> .....	11
<i>Encoder Time Setting</i> .....	12
<i>Questions And Answers About Compact Flash Time-Setting</i> .....	12
<i>Compact Flash Usage</i> .....	13
<i>Start Recording</i> .....	13
PROTECTED PINS .....	14
<i>Electrical Interference</i> .....	14
<i>Caring For The Fiber Optic Cable</i> .....	15
<b>SENSORS</b> .....	<b>16</b>
GENERAL SENSOR FACTS .....	16
<i>Sensor Anatomy</i> .....	16
<i>Contact With The Client's Skin</i> .....	16
<i>Sensor Care</i> .....	17
SURFACE ELECTROMYOGRAPHY (SEMG) .....	17
<i>Sensor Types</i> .....	17
<i>Operating Principle</i> .....	17
<i>Measurement Unit</i> .....	18
<i>Sensor Placement</i> .....	18
<i>Typical Signal</i> .....	18
<i>Zeroing</i> .....	18
ELECTROCARDIOGRAPHY (EKG) .....	19
<i>Sensor Type</i> .....	19
<i>Operating Principle</i> .....	19
<i>Measurement Unit</i> .....	19
<i>Sensor Placement</i> .....	19
<i>Typical Signal</i> .....	20
ELECTROENCEPHALOGRAPHY: EEG FLEX/PRO AND EEG-Z .....	20
<i>Sensor Type</i> .....	20
<i>Operating Principle</i> .....	20
<i>Measurement Unit</i> .....	20
<i>Sensor Placement</i> .....	21
<i>Impedance Checking</i> .....	21
<i>10-20 EEG Electrode Placement System</i> .....	22
<i>Typical Signal</i> .....	23
SKIN CONDUCTANCE: SC FLEX/PRO .....	24
<i>Sensor Type</i> .....	24
<i>Operating Principle</i> .....	24
<i>Measurement Unit</i> .....	24
<i>Sensor Placement</i> .....	24
<i>Typical Signal</i> .....	24
PERIPHERAL TEMPERATURE .....	25
<i>Sensor Type</i> .....	25
<i>Operating Principle</i> .....	25
<i>Measurement Unit</i> .....	25
<i>Sensor Placement</i> .....	25
<i>Typical Signal</i> .....	25

BLOOD VOLUME PULSE.....	25
<i>Sensor Type</i> .....	25
<i>Operating Principle</i> .....	25
<i>Measurement Unit</i> .....	26
<i>Sensor Placement</i> .....	26
<i>Typical Signal</i> .....	26
RESPIRATION AMPLITUDE: RESP FLEX/PRO .....	26
<i>Sensor Type</i> .....	26
<i>Operating Principle</i> .....	26
<i>Measurement Unit</i> .....	26
<i>Sensor Placement</i> .....	27
<i>Typical Signal</i> .....	27
<b>SELF-CALIBRATION</b> .....	<b>28</b>
<b>CONDITION CODE SUMMARY</b> .....	<b>29</b>
<b>REFERENCE</b> .....	<b>30</b>
TECHNICAL SUPPORT AND ORDER PLACING .....	30
<i>Returning Equipment</i> .....	30
TECHNICAL SUPPORT .....	30
<b>PRODUCT NUMBERS &amp; ACCESSORIES</b> .....	<b>31</b>
PROCOMP INFINITI ENCODER & SENSORS .....	31
ACCESSORIES.....	31
<b>PLACING ORDERS</b> .....	<b>32</b>
<b>SPECIFICATIONS</b> .....	<b>33</b>
<b>INDEX</b> .....	<b>37</b>
<b>INFINITI HARDWARE COPYRIGHT NOTICE</b> .....	<b>40</b>

# Introduction

The ProComp Infiniti™ encoder is an eight (8) channel, multi-modality device for real-time computerized biofeedback and data acquisition. It has 8 protected pin sensor inputs with two channels sampled at 2048 s/s and six channels sampled at 256 s/s. The ProComp Infiniti encoder is able to render a wide and comprehensive range of objective physiological signs used in clinical observation and biofeedback.



The ProComp Infiniti basic package includes the following hardware:

- One eight-channel ProComp Infiniti encoder unit
- One TT-USB interface unit
- A supply of fiber optic cable (1' and 10' cables)
- Four alkaline 'AA' batteries

Thought Technology's advanced design and active electronic sensors meet exacting standards for instrument accuracy, sensitivity, durability, and ease of use. All sensors are completely non-invasive and require little or no preparation for use. Depending on the software being used with the ProComp Infiniti encoder, these may include sensors specialized for:

- Electromyography (EMG)
- Electroencephalography (EEG)
- Skin Temperature
- Respiration waveform, rate, and amplitude
- Blood Volume Pulse waveform, heart rate, and amplitude (BVP)
- Electrocardiography (EKG)
- Skin Conductance
- Voltage Isolation
- Goniometer
- Force
- Torsiometer

The sensors pass signals to the host computer via the microprocessor-controlled ProComp Infiniti encoder unit. The encoder samples the incoming signals, digitizes, encodes, and transmits the sampled data to the TT-USB interface unit. A fiber optic cable is used for transmission, providing maximum freedom of movement, signal fidelity, and electrical isolation. Cable lengths up to 25 feet can be used without signal degradation. A unique feature of the system design allows inputs to accept any sensor, interchangeably (except the raw EMG MyoScan sensors which are used on channel A and B). This allows a wide variety of configurations to be created by simply changing the sensor types.

The TT-USB interface unit is connected to one of the host computer's USB ports. It receives the data arriving from the encoder in optical form and converts it into the USB format to communicate with the software.

**Please note, some hardware features may not be supported by all software programs. Consult the software manual for a full list of features supported.**

**Please note, some software programs will not function with a TT-USB, but require use of a PRO-SB in its place.**

# Connecting the Encoder, TT-USB and Sensors

---

## SETTING UP THE ENCODER UNIT

Cut a convenient length of fiber optic cable cleanly and evenly using a sharp blade, or use the whole length rolled up out of the way.

**IMPORTANT:** *Winding the fiber optic cable in a loop smaller than 4 inches (10 cm) or bending it sharply will damage the cable!*

1. Plug the USB cable connected to the TT-USB interface unit supplied with the USB connector on the computer being used. (If using the BioGraph® 2.1 software please use the Pro-SB in place of the TT-USB as described in the BioGraph® 2.1 software manual.)
2. Insert one end of the fiber optic cable into the optical receiver jack on the rear face of the TT-USB Interface unit and the other into the optical transmitter jack on the front of the ProComp Infiniti encoder. Before inserting the cable, it may be necessary to loosen the jack heads by turning them counter-clockwise.
3. Ensure that both ends of the optical cable are inserted all the way (about  $\frac{3}{4}$  of an inch, 1.9 cm) into the jacks and that the heads are screwed down firmly.
4. Wind excess fiber optic cable into a large loop (approx. 6 inches, 15 cm).
5. Plug the sensors you wish to use into the input jacks on the front of the encoder unit.
6. Load four 1.5 V Alkaline or rechargeable Nickel-Metal Hydride (NiMH) batteries into the encoder unit's battery pack; check battery orientation being sure to respect the polarities indicated on the inside of the battery compartment.
7. Push the encoder unit's power button for 1 second.
8. Check that the encoder's blue 'ON' indicator directly above the ON button is lit; if it is not, check the condition and orientation of your batteries.
9. To switch the encoder 'OFF' push the power button for 1 second and ensure that the blue indicator is no longer lit.

You may leave the encoder unit power ON if you intend to continue on to the following sections.



# ENCODER DIP SWITCH SETUP

ProComp Infiniti encoder units have switches located on the bottom of the unit to the left of the belt clip. The switches can be flipped up and down to a 1 or a 0 (zero) position with the aid of a paper clip or small pointed object. With the front of the encoder facing up, verify that the switches are set properly for the software in use. Below is an example of the switch with the depressed position indicated. The Black section represents the depressed state.

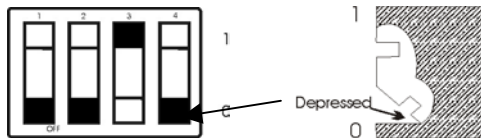
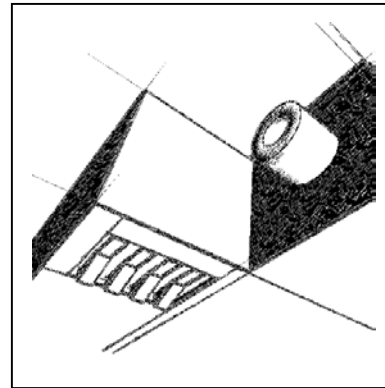

For use with the ProComp BioGraph Infiniti software and the TT-USB interface:  
 Channels A & B 2048 samples/second  
 Channels C to J 256 samples/second

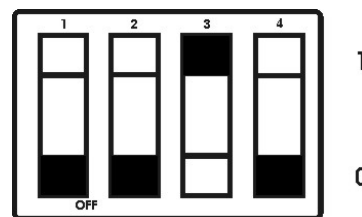

For use with the BioGraph, CardioPro or MultiTrace software and the ProSB interface:  
 Channels A & B 256 samples/second,  
 Channels C to H 32 samples/second.

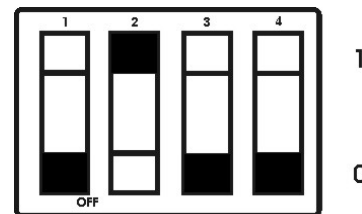

For use with the BioResearch software and the ProSB interface:  
 Channels A & B 200 samples/second,  
 Channels C to H 20 samples/second.

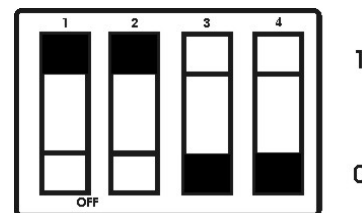

For use with the Neurocybernetics (EEG Spectrum), NeuroCare Pro software and the ProSB interface:  
 Channels A & B 256 samples/second,  
 Channels C to H 32 samples/second.

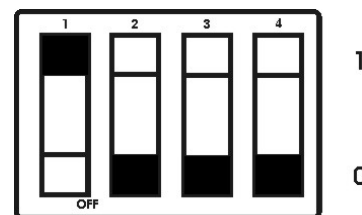

All other switch settings are reserved for later use.

## Battery Placement

### Opening The Compartment

Looking at the underside of the ProComp Infiniti device, you will see a long door in the plastic enclosure. Holding the encoder with the connectors facing you and with the door up, push lightly down and back with your thumbs on the door to slide it open.

#### **Attention:**

*The internal workings of the ProComp Infiniti encoder is not intended to be opened for repair except by qualified service personnel. The tamper-evident seal under the batteries in the battery compartment should not be removed or broken. Thought Technology may refuse to honor the unit's warranty if the seal is broken.*

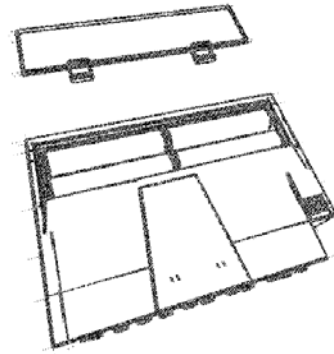

### Polarity

When the compartment cover has been slid out, place four AA batteries in the slots, observing the polarity as illustrated. Please note that a diagram of the correct battery polarity is embossed on the inside surface of the compartment.

### Closing The Compartment

Slide the door back into the ProComp Infiniti case, gently pushing it in until you feel the click of the locking mechanism.

### Keeping An Eye On The Battery Level

Since each sensor draws a small amount of power from the batteries when connected to the ProComp Infiniti, it is better to connect only the sensors that are going to be used for a session before you start recording; this will ensure maximal battery life. Most Thought Technology software applications will display a battery power indicator; we recommend that you replace the batteries as soon as this indicator falls below about 50% of the battery power.

---

## COMPACT FLASH

The compact flash (CF) is used as an alternative storage medium for data being recorded by the encoder. The CF card is a small square approximately the size of a box of matches and is inserted into the rear surface of the encoder with its label facing up. The encoder is delivered with a protective insert in the compact flash slot. To remove it, push the button next to the slot once to eject the button, then push again to remove the card, pushing the button back in. The CF card can then be inserted; you will notice that the CF card can only be inserted one way into the encoder to protect from incorrect insertion. When inserted properly it will be flush with the encoder rear. Follow the procedure above to remove this card when no longer required, and re-insert the protective insert. CF cards require a CF card reader to transfer data to the PC. The CF cards and reader can be purchased from most computer stores. Before its first use in the encoder, a CF card requires PC formatting using the file manager. With the CF card inserted into the reader connected to the PC, from Windows open the file manager and identify the Removable Drive. Right click the removable drive and select Format.

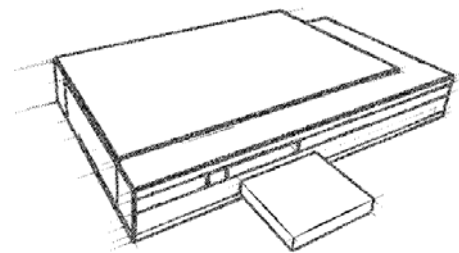

Select Format Type Full, if using Windows® XP select file system **FAT** not **FAT32** and select Start. When this is complete use the single master file build function provided by the Infiniti Software to finish the process.

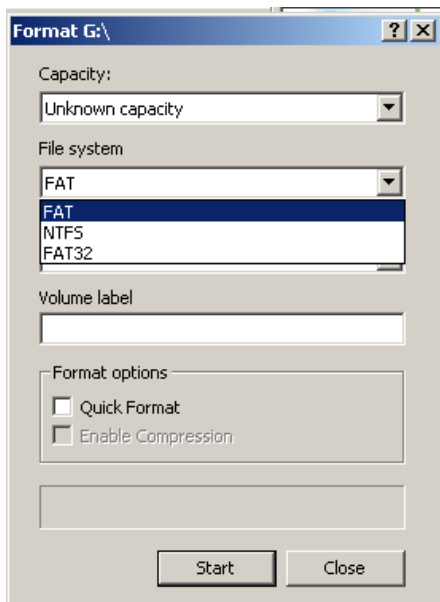

It is recommended that you temporarily disable any virus scanning utility while formatting the Compact Flash as this will considerably increase the speed of the process.

**Attention:**

*Formatting CF Card with File System other than FAT will render it Inoperable.*

*Users should follow the appropriate procedures used for disconnecting peripheral devices when unplugging the Compact Card from its PC reader.*

## Compact Flash Setup

### Compact Flash Rebuilding

To rebuild the Compact Flash for use in the encoder, follow these steps:

1. Place the CF card in the CF Card Reader connected to the PC.
2. From the Infiniti software's main screen, select "Compact Flash Options", and then "Rebuild Compact Flash".
3. Select the "Create" option and press OK. Wait for the operation to complete. This may take some time, especially for larger Compact Flash cards.
4. After the operation has concluded, you may remove the CF card from the reader. It is now ready for use in the encoder. However, you may wish to first initialize the Compact Flash card so that the encoder's date and time will be set (see below).

**Attention:**

*Never use a CF card previously used with other devices for recording with the ProComp Infiniti. Thought Technology's rebuilding process creates a single file on the CF card. **Do not delete or overwrite this file, or attempt to create any other files on the Compact Flash once it has been formatted!***

*If the Thought Technology format file is overwritten or deleted, the CF card may need to be re-formatted first to its original PC format, using the Format facility of your PC's operating system. If you need to do this, choose the FAT16 file system for best results. After doing this, use the Thought Technology rebuilding option again. If you are unsure how to do this operation please contact technical support for more information.*

## Encoder Time Setting

The encoder has an internal clock to enable time and date stamping of the sessions recorded onto the CF card. **The encoder will retain its time and date when batteries are changed if the fresh batteries are inserted within 30 seconds of removing the old ones.** If the time is lost it will reinitialize to January 1 2000. As part of the CF formatting procedure you may wish to set up the date and time for the encoder, so that sessions can be time stamped for future reference.

To set the date and time follow these steps:

- Insert the CF card into the CF card reader
- If not already selected, from the Infiniti software's main screen, select "Compact Flash Options". Then select "Set Compact Flash Date/Time".
- Specify a date and time, a brief period in the future, when you will insert the Compact Flash in the encoder. Press OK and wait for the operation to complete.
- If off, turn on the encoder. Remove the CF card from the reader and as close as possible to the specified time, insert it into the encoder. The time setting will immediately take effect, and will set the encoder's internal clock to the specified date and time.

## Questions And Answers About Compact Flash Time-Setting

**Question** My batteries have died in my encoder. Will I need to reset my encoder time and date?

**Answer** No. Old batteries, even if they are too dead to operate the encoder, will keep the clock running for a long time. When you do change your batteries, be sure to put in the fresh ones within 30 seconds of removing the old ones, in order to retain the date and time setting.

**Question** My batteries died a number of weeks ago, and they were removed for longer than 30 seconds. How do I reset the time?

**Answer** Follow the directions above under Encoder Time Setting.

**Question** I recorded some sessions after the battery was removed for more than 30 seconds, so the encoder time may have been lost. What date and time will they have?

**Answer** The date and time will be marked as invalid and will not be available for these sessions. For each session recorded with an invalid time, the software will prompt you for the starting time of the session. So if you know that the time is invalid on the encoder, be sure to note the starting time of each session, if this information is important.

## Compact Flash Usage

When a Compact Flash module is inserted in the unit (or the unit is turned on with a CF inserted) and is recognized as a valid Compact Flash, the CF LED turns on for about 1 second, then blinks in a single burst, a number of times to indicate available space. The CF LED then goes out, awaiting a switch command. If no space remains on the Compact Flash, only the initial 1-second blink is performed. This sequence is replayed when the dipswitch is changed.

Memory Remaining											
Initial 1 Sec	0%	10%	20%	30%	40%	50%	60%	70%	80%	90%	100%
*											
*		*									
*		*	*								
*		*	*	*							
*		*	*	*	*						
*		*	*	*	*	*					
*		*	*	*	*	*	*				
*		*	*	*	*	*	*	*			
*		*	*	*	*	*	*	*	*		
*		*	*	*	*	*	*	*	*	*	
*		*	*	*	*	*	*	*	*	*	*

If the card is not recognized as a valid Compact Flash, the CF LED blinks quickly (about 10 times per second) for between 1 and 2 seconds, then blinks slowly a number of times indicating an error code. The error code blink is repeated a total of 3 times. The CF LED then goes out.

## Start Recording

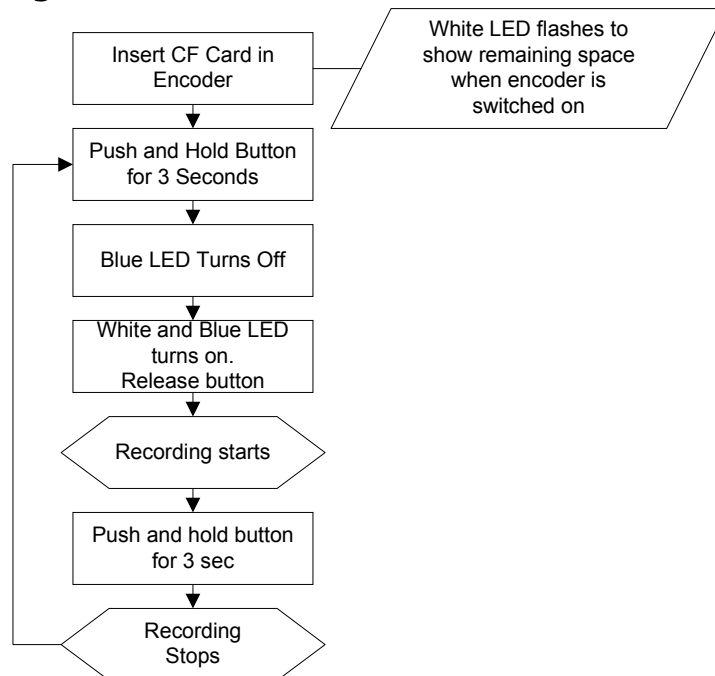

1. CF Recording is started by pressing and holding the button for about 3 seconds, or until the white LED turns on.
2. First, the blue LED will turn off, and releasing the button during this period will cause the encoder to turn off.
3. After the white LED turns on, the button may be released.

4. At this point, the white LED turns off, then outputs the same sequence as described above.
5. CF Record Command is entered if a CF is inserted, recognized as a valid CF and at least one sensor has been plugged in.
6. If the CF is recognized but there is no sensor plugged in, the white LED will never turn on.
7. During the recording, the CF LED blinks to indicate the percentage of the total CF storage space, which remains available for recording.
8. It blinks in groups of 1 to 10 flashes. 1 flash = 10% remaining, 10 flashes = 100% remaining.
9. CF Record is stopped by pressing and holding the button for about 1 second, or until the white LED turns and stays on, then release the button.
10. If the CF is full or the CF is removed during the recording, the unit will stop the recording itself. With removal a maximum of 1 second of recording will be lost.

Refer to software instructions for detailed information on transferring sessions from the Compact Flash card to the computer.

**Attention:** Do not remove the CF card without first stopping recording. If the CF card is removed during recording, generally only the last second will be lost; however there is a small risk of greater data loss.

---

## PROTECTED PINS

A number of regulatory bodies (like the FDA in the USA) have adopted safety specifications requiring that all medical products for physiological monitoring be manufactured with electrode leads that have no exposed metal plugs. For this reason, the ProComp Infiniti encoder and all our sensors use specially designed connectors that have all metallic surfaces recessed within the plastic casing. These connectors, with protected pins, require some care when plugging and unplugging the sensors to the ProComp device or the extender cable to the sensor head.

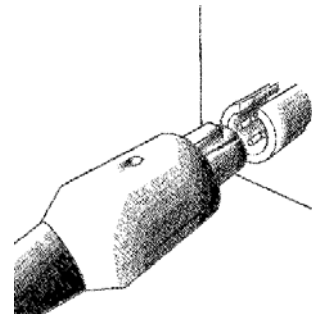

When connecting a sensor, be sure to properly line up the guiding dot on the top of the plug with the notch in the encoder's input socket. Forcing the plug into the jack in any other position may damage your equipment.

### Electrical Interference

When performing a biofeedback session, it is best to **avoid placing the ProComp Infiniti near the computer, display monitor or any other electrical device**, where it can be exposed to electromagnetic fields. We recommend that you try to keep the encoder within the client's natural electrical field. In most cases, you can do so by fastening the belt-clip to the client's waist.

## Caring For The Fiber Optic Cable

A fiber optic (FO) cable is used for transmitting the sensor data to the computer. Although this technology provides maximal electrical isolation, signal fidelity and freedom of movement, some care has to be taken when handling the fiber optic cable, as it is much less flexible than a regular electric wire.

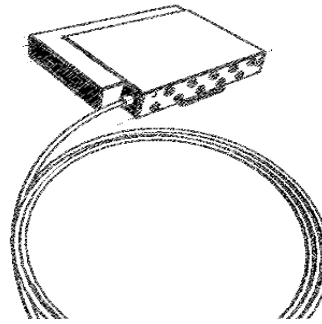

### Winding Or Bending

It is most important to avoid bending the cable too sharply. In a FO cable, information travels as light impulses. Any kink along the optical fiber may partially or completely block the light's path and, thus, interrupt the flow of sensor information to the computer. When using your system, try to keep the extra length of cable wound in a loose loop no smaller than about 4 inches (10 cm) in diameter.

### Shorter Length Of Fiber Optic Cable

Although we ship the ProComp Infiniti system with one short and one long FO cable, the short length should only be used as a troubleshooting tool because it is too short and forces the ProComp Infiniti to stay too close to the computer. Should you suspect a problem with the long FO cable, replace it with the short one and see if you can establish a good connection. If the system works well with the short cable, then you probably have a break in the longer one. Holding it lightly between your thumb and index fingers, feel along the whole length of the cable, searching for kinks. If you do find a break, the optic fibers may be too damaged to let the light pass properly. Using a sharp, carpet cutter type blade, you can slice the FO cable into shorter, unkinked bits. We do not recommend using scissors because they make a V-shaped cut that may impede the data stream.

### TT-USB And Encoder Connections

The FO connector on the ProComp Infiniti and the TT-USB Interface are susceptible to breaking when they are hit directly. This can occur if the ProComp Infiniti is dropped on the floor. Whenever possible, fasten the device to the client or to a chair, using the belt clip. On the TT-USB Interface, you will also notice a hole labeled Switch. This plug is for connecting external devices, such as a muscle stimulation device, when you want to use the switch control feedback option in the software.

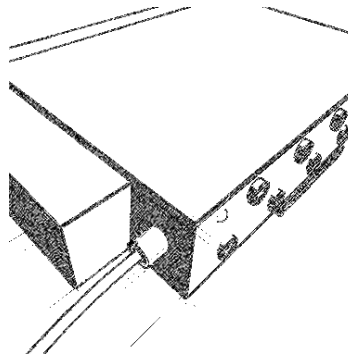

The TT-USB receives the data from the ProComp Infiniti encoder via the fiber optic and sends it on to the computer via the USB port. It has four connectors;

1. Fiber Optic Connector – Connects to Fiber Optic Cable from encoder.
2. Mini USB Connector – Connects via USB cable to computer.
3. Switch Connector – Connects via a 3.5mm jack acts as a computer controlled switch.
4. Sync Connector – Connects to optional sync cable to connect more than one TT-USB interface together to synchronize data between units. This input can also be used as an event input.

# Sensors

---

## GENERAL SENSOR FACTS

Thought Technology sensors are completely non-invasive and require little or no skin preparation when used for feedback purposes. They include sensors specialized for electromyography (EMG), electroencephalography (EEG), electrocardiography (EKG), blood volume pulse (BVP), skin conductance (SC), respiration and temperature.

### Sensor Anatomy

The EMG, EKG and EEG sensors have a positive, a negative and a ground electrode. The signal is measured between the positive and negative. The ground acts as a reference point, and is used for filtering out electrical "noise" that is picked up from all three electrodes.

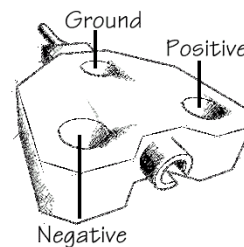

### Contact With The Client's Skin

Because some biofeedback sensors are applied directly to the skin or scalp, some consideration must be given to using proper hygienic controls. Whenever possible, we recommend the use of disposable electrodes. The electrodes on skin conductance sensors are replaceable but not disposable, and must be changed after 50 uses to ensure an accurate reading (or sooner on signs of corrosion). They must be cleaned with an alcohol wipe after each use.

#### Disposable Electrodes

Before an EMG or EKG sensor can be placed on the client, you must snap on a set of disposable electrodes. Three types of electrodes are available from Thought Technology: Triodes, Single-Strip and Uni-Gels. The Triode and Single electrodes are dry, while the Uni-Gel electrodes are covered with a thin layer of conductive gel, to enhance their contact with the client's skin. All three types are designed like snap-on buttons. The Triode electrodes can be snapped directly onto the sensor head. The Single and Uni-Gel electrodes are designed to be used with extender cables.

#### Skin Preparation

Many physiological monitoring devices will require you to prepare the client's skin before positioning the sensors. Because they have high input impedance, the Thought Technology sensors can be utilized with little or no skin preparation, depending on the purpose of your intervention. For most biofeedback applications, simply cleaning the skin with a bit of cotton and rubbing alcohol is sufficient to ensure good sensor readings. For EEG neurofeedback and muscle function assessments using EMG, we recommend that you use abrasive paste and conductive gel. Since body hair can form an insulating layer between the skin and the electrode surface, be careful not to place the electrodes over hairy areas. In some cases, shaving may be required.



## Sensor Care

### Triodes And Extender Cables

The EMG sensor can be used with a Triode electrode, snapped onto the sensor head, or with Single electrodes, individually snapped onto each of the three leads of an extender cable. If you have to alternate between the two methods, make sure to leave only one set of electrodes connected to the sensor at any one time. Forgetting to remove the unused electrodes could degrade the quality of the recorded signal because of extra susceptibility to noise.

### Equipment Storage

As a general rule, we recommend that you remove any electrodes from the sensor heads and extender cable leads when you are done using your equipment. To avoid the possibility of corrosion of the snap connectors, only use Thought Technology triode's with metal snaps. Using one part silver-Silver Chloride electrodes promote corrosion and may void your warranty. Many electrodes are coated with a very conductive substance that can cause the sensor's metal parts to corrode if they are left in contact with it for long periods of time. Also, please be careful, when unsnapping electrodes, not to damage the wires. Avoid twisting and pulling on the wires by holding the sensor head, the connector itself or the extender cable's rounded snap.

---

## SURFACE ELECTROMYOGRAPHY (SEMG)

### Sensor Types

The MyoScan and the MyoScan-Pro are the surface EMG (SEMG) sensors for the ProComp Infiniti device. SEMG is recorded from a sensor that is placed on the skin's surface. The MyoScan-Pro sensors can be used on any input; the MyoScan-Pro automatically converts this signal to a root mean square (RMS) signal (an analog rectification is done inside the circuitry). The result is a slower signal, which can be sampled at a low rate without distortion. MyoScan sensors are used on inputs A or B, which sample at 2048 s/s. The sensor captures raw EMG at frequencies up to 500 Hertz (Hz) and maintains the signal in its faster RAW format.

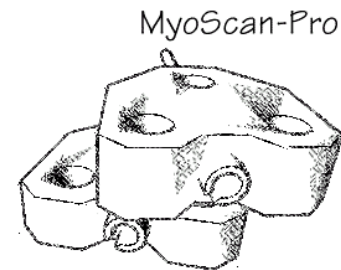

### Operating Principle

EMG measures muscle activity by detecting and amplifying the tiny electrical impulses that are generated by muscle fibers when they contract. Since all the muscle fibers within the recording area of the sensor contract at different rates, the signal detected by the sensor is a constantly varying difference of potential between its positive and negative electrodes. The number of muscle fibers that are recruited during any given contraction depends on the force required to perform the movement. Because of this, the intensity (amplitude) of the resulting electrical signal is proportional to the strength of contraction.

## Measurement Unit

The MyoScan-Pro sensor's active range is from 20 to 500 Hz. It can record SEMG signals of up to 1600 microvolts ( $\mu\text{V}$ ), RMS. On the back of the sensor, there is a small switch with three positions: 400N, 1600W and 400W. In the 400W (wide bandwidth) position, the sensor will be sensitive to the full 20-500Hz bandwidth. When recording SEMG from the upper body muscles, the sensor might pick up some electrical interference from the heart muscle, which is usually seen as a sharp spike occurring at every heartbeat. This noise can be filtered out by moving the switch to the 400N (narrow bandwidth) position. In this position, the sensor will only be sensitive to frequencies between 100 and 200 Hz. The third position, 1600W is for monitoring large muscle groups like thigh muscles. At the 400W or 400N positions, the sensor's amplitude scale is 400  $\mu\text{V}$ , which allows for a good resolution for most of the body's muscles. The larger body muscles can produce microvolt readings of up-to 1600  $\mu\text{V}$ . To properly monitor their activity, set the sensor to the 1600W position.

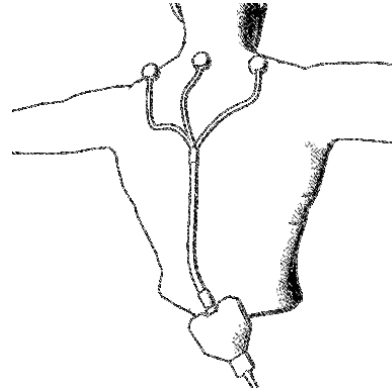

The MyoScan sensor's active range is from 10 to 500 Hz. It can record SEMG signals from zero up to 2000 microvolts ( $\mu\text{V}$ ).

## Sensor Placement

When placing an SEMG sensor on a muscle site, the best readings are obtained when the sensor is placed on the muscle belly and its positive and negative electrodes are parallel to the muscle fibers. When using the extender cable, though, the direction of the fibers becomes irrelevant since the electrodes are frequently placed on different muscle groups. The positive and negative electrodes should still be placed on the muscle bellies. The reference electrode is best placed on a relatively neutral site, like a bony prominence, preferably at an equal distance from the other two electrodes.

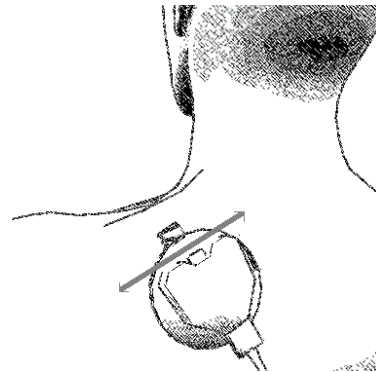

## Typical Signal

The typical waveform of an RMS SEMG signal is shown below:

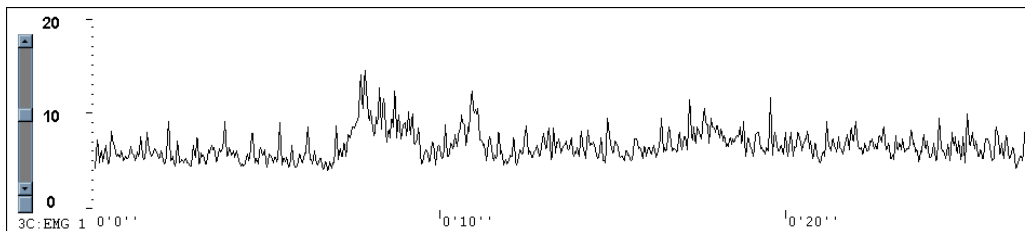

Changes in amplitude are directly proportional to the muscle's activity. Normal resting values are usually around 3 to 5  $\mu\text{V}$  (they can be as low as .3 or even less for a profoundly relaxed muscle).

## Zeroing

Since the MyoScan-Pro uses internal electronic circuitry to perform RMS rectification from within the sensor, it is sometimes possible to observe slight offsets in sensor reading. This is particularly obvious with older sensors and at low EMG values (less than 5 $\mu\text{V}$ ). For that reason, it will occasionally be necessary to zero your MyoScan-Pro sensors. Zeroing is done by connecting the zeroing plug to the

sensor box while recording (plug it where the extender cable connects). With the zeroing plug on the sensor, the reading should be zero. If your software displays a different value, usually plus or minus a few microvolts, then you should be able to correct this offset, from within the software, by using a zeroing function. Keep in mind that each sensor may have different offset values. If you zero a particular MyoScan-Pro on a given display screen, then you must always connect the same sensor to the same encoder input when you use that screen. **Remember to remove the zeroing plug after adjusting the MyoScan-Pro sensor's offset.**

**NOTE:** Zeroing is not required for the MyoScan sensor, which displays raw signals.

---

## ELECTROCARDIOGRAPHY (EKG)

### Sensor Type

To record EKG on the ProComp Infiniti, use an EKG-Flex/Pro sensor. Although a signal can be detected by applying an EKG sensor, with Triode electrodes snapped on, anywhere on the client's chest, using an extender cable and Uni-Gel electrodes greatly enhances the quality of the EKG signal.

### Operating Principle

EKG is similar to EMG: The sensor detects and amplifies the small electrical voltage that is generated by the heart muscle when it contracts.

### Measurement Unit

The actual EKG signal is measured in microvolts ( $\mu\text{V}$ ). Most often, though, the clinically useful measures are those that are computed from the raw EKG: the heart rate (HR) and its inverse, the inter-beat interval (IBI). HR is measured in beats per minute (B/min or Bm) and IBI, in milliseconds (ms).

### Sensor Placement

The standard EKG electrode placement requires that the negative electrode be placed on the right shoulder, the positive electrode be placed on lower center or left side of the chest (xyphoid process) and the ground electrode, on the left shoulder. When a chest placement is impossible or too invasive, it is possible to place the electrodes on the client's forearms. For a forearm placement, the negative lead should be placed on the right forearm, while both the positive and ground leads are placed on the left forearm.

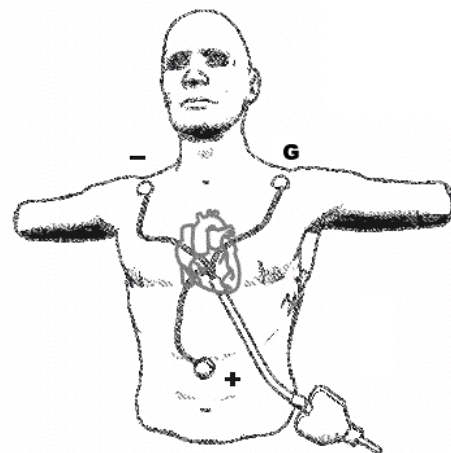

## Typical Signal

When the electrodes are placed as described above, the typical signal should look similar to the illustration below. A sharply defined upward "R" spike is expected by the software in order to calculate the heart rate properly.

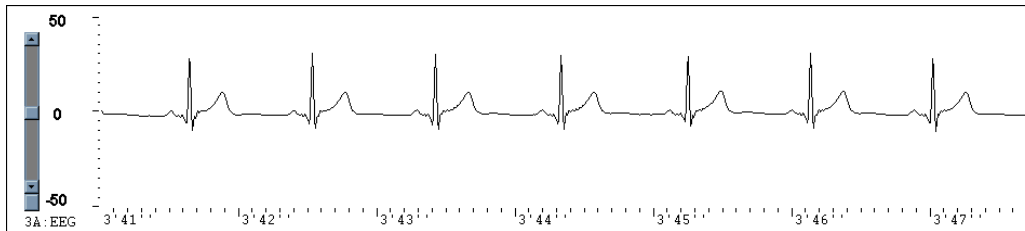

---

# ELECTROENCEPHALOGRAPHY: EEG FLEX/PRO AND EEG-Z

## Sensor Type

To record EEG on the ProComp Infiniti, use an EEG-Flex/Pro or EEG-Z sensor. Unlike the EMG and EKG sensors, the EEG sensor will not be able to detect a good quality EEG signal without the use of extender leads and proper electrodes. The EEG-Z is identical to the EEG Flex/Pro, it incorporates an automated three-lead impedance checking function.

## Operating Principle

The EEG sensor detects and amplifies the small electrical voltages that are generated by brain cells (neurons) when they fire. Similarly to muscle fibers, neurons of different locations can fire at different rates. The frequencies most commonly looked at, for EEG, are between 1 and 40 Hz. The EEG sensor records a "raw" EEG signal, which is the constantly varying difference of potential between the positive and negative electrode, and the software processes that signal by applying a variety of digital filters to the recorded signal, in order to extract frequency-domain information. Note: EEG practitioners call the negative electrode "reference" and the positive electrode "signal."

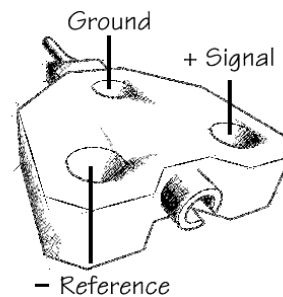

## Measurement Unit

The EEG-Flex/Pro sensor measures microvolts ( $\mu\text{V}$ ), raw. A normal EEG signal, recorded from the scalp, will have an amplitude between 0.1 and about 200  $\mu\text{V}$ . The raw EEG signal is mainly used to evaluate the quality of the recorded signal and to do artifact rejection. For biofeedback purposes, clinicians will usually want to filter out subsets of the whole EEG bandwidth and measure the real-time changes in the total power generated by all the frequencies in the subset. Generally, the most frequently observed frequency subsets are defined as: High Beta 20-40 Hz, Beta 15-20 Hz, Sensorimotor Rhythm (SMR) 13-15 Hz, Alpha 8-13 Hz, Theta 4-8 Hz and Delta 2-4 Hz. The frequencies above 40 Hz are interpreted as EMG noise from neighboring muscles.

## Sensor Placement

The EEG sensor, like the EMG and EKG sensors, has three electrodes. The positive one is called the "signal" electrode. The negative one is the reference and the third one is the ground. For EEG applications, the regular Triode, Single Strip or Uni-Gel electrodes are not appropriate. Thought Technology manufactures three types of EEG extender cables: monopolar, bipolar and monopolar with linked ears. These extender cables have small tin cups at the end of each lead. For clinicians who prefer using third-party electrodes (silver or gold), a fourth type of EEG extender cable, with three standard DIN connectors, is available.

Prior to placing EEG electrodes on a client's head, it is recommended to gently rub the placement areas, and ear lobes, with a bit of abrasive paste. This will remove the surface layer of dead skin and improve the electrode's contact with the skin. If you are using the EEG-Z sensor you can put the encoder into impedance-checking mode in order to gauge the effectiveness of such skin preparation (see below under Impedance Checking).

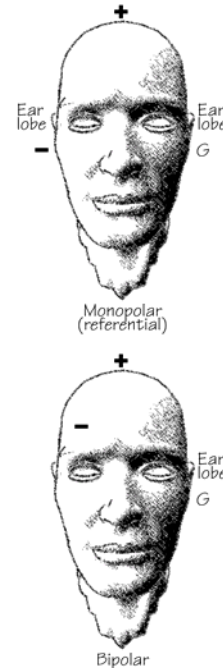

To place the EEG electrodes, fill the tin cups with a generous amount of EEG conductive paste and press it down over the desired spot until the cup is firmly in place. When you do this, some of the paste will be squeezed out of the small hole in the cup; that is expected. You may want to help hold the cup down by pressing on it with a small cotton ball. The cotton ball can be left on the client's head until you remove the electrodes. The monopolar extender cable has one cup and two ear clips. The cup should be placed on an active EEG site - all standard sites for EEG are defined by the 10-20 EEG electrode placement system (see next page). The reference ear clip should be placed on the ear lobe, on the same side as the active site, and the ground ear clip on the ear lobe of the other side. The monopolar placement, frequently called referential placement, is the most commonly used for EEG biofeedback.

A bipolar placement involves recording one signal between two active sites using one sensor. For this placement, you need to place the positive and reference electrodes on two standard EEG locations, usually on the same side of the brain. The ground electrode has an ear clip and should be placed on the earlobe of the opposite side. (Note: bipolar is not the same as bilateral. A bipolar placement provides only one signal. A bilateral placement requires two sensors and gives two signals.) When you want to use two EEG sensors, the electrode placements are similar, except that you do not need to place both ground electrodes on the client; you can leave one ground lead loose.

## Impedance Checking

When one or more EEG-Z sensors are plugged into the ProComp Infiniti encoder, and when the encoder is set up in ProComp Infiniti mode, it is possible to invoke the sensors' impedance checking function. To do this, press and hold the power button for approximately 3 seconds, or until you see the blue LED blink quickly 2 times. Then release the power button.

In this mode, any EEG-Z sensors that are plugged into the encoder are commanded one after the other to perform an impedance check. The results may be read from the BioGraph Infiniti software to which the encoder is connected. The impedance checking continues, in round-robin order, as long as the mode is selected. It takes about 1 second to check impedance on each sensor, and the total time to complete the entire set of sensors depends on the number plugged into the encoder.

EEG readings from the encoder are not valid while impedance checking is occurring, and any traces will be replaced by signals used in the impedance check process.

### **Attention**

A set of EEG-Z sensors all connected to the same encoder will not interfere with each other's impedance check readings, as they are commanded to perform their impedance checks sequentially, and are designed to disconnect from the client while not checking impedance. However, sensor types other than EEG-Z that are electrically connected to the client can potentially affect the impedance readings obtained from EEG-Z sensors.

If possible, leave other electrically connected sensors (such as EMG, EKG, SC) unconnected during EEG-Z impedance checking, or else perform a test to see whether their connection causes a significant change in the reading.

Sensors (even EEG-Z sensors) attached to the same client but connected to *another encoder* also have the potential to affect EEG-Z readings. In particular, do not attempt to perform impedance checking on two encoders on a single client, at the same time. Here again, test for the effect of other connected sensors if you are concerned about receiving precise impedance readings.

## **10-20 EEG Electrode Placement System**

To get a full understanding of the standard 10-20 EEG electrode placement system, please refer to professional publications on EEG. This section will only give you an introduction on the subject.

Since no two people have the same head size and shape, the first step in defining correct electrode locations is to make some measurements. Two measures are required: The distance between the supra-nasal groove (nasion) and the little bump in the mid occipital region (inion) and, the distance between the two pre-auricular notches (this is the dimple just in front and slightly above the tragus). Once these two distances are measured, you need to find the spot over which the two lines bisect at their mid-point. Calculate 50% of both measures and find the point, on the client's head, where they cross over. That point is called Cz, and it is the first 10-20 location that you need to identify. Use a washable marker to mark the spot.

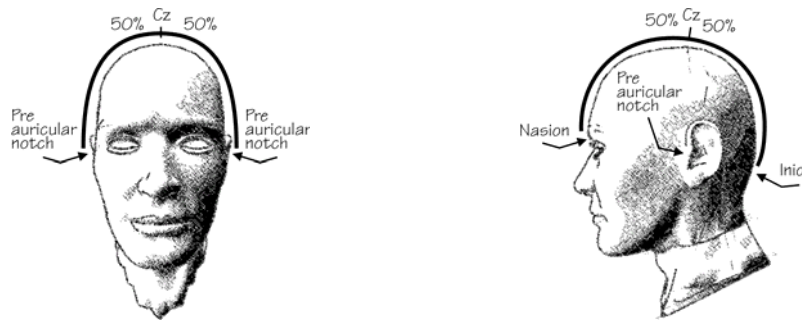

From Cz, you can easily find C3 and C4 by moving laterally towards each ear, along the imaginary line that you drew between the pre-auricular notches. C3 is 20% of the full distance towards the left and C4, 20% of the full distance to the right. C3 and C4 are also very important points for EEG biofeedback.

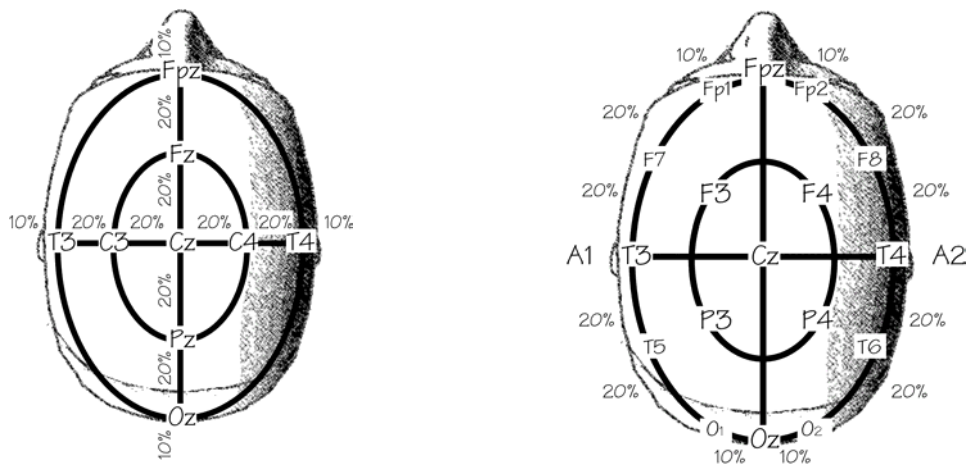

To identify the other locations, please refer to the illustrations. 20% to the left of C3, you will find T3. 20% to the right of C4, you will find T4. There should be 10% of the whole distance left, on each side, to the pre-auricular notches. Similarly, find Fz and Pz, 20% from Cz, along the nasion/inion line and then Fpz and Oz, another 20% from Fz and Pz, respectively. There should be 10% left above the nasion and inion. A1 and A2 are the ear lobes. F3, F4, P3 and P4 are at 50% of the distance between C3, Fz, C4 and Pz. Measuring a straight line between these points is acceptable. Finally, calculate the distances between Fpz and T3, Fpz and T4, Oz and T3 and Oz and T4. Calculate 10%, on either sides of Fpz and find Fp1 and Fp2. Calculate 10% on either sides of Oz and find O1 and O2. At 20% on either sides of T3, find F7 and T5. At 20% on either sides of T4, find F8 and T6. There are 10-20 placement maps that represent many more points. For most biofeedback applications, the ones listed above are all you should ever need to identify.

### Typical Signal

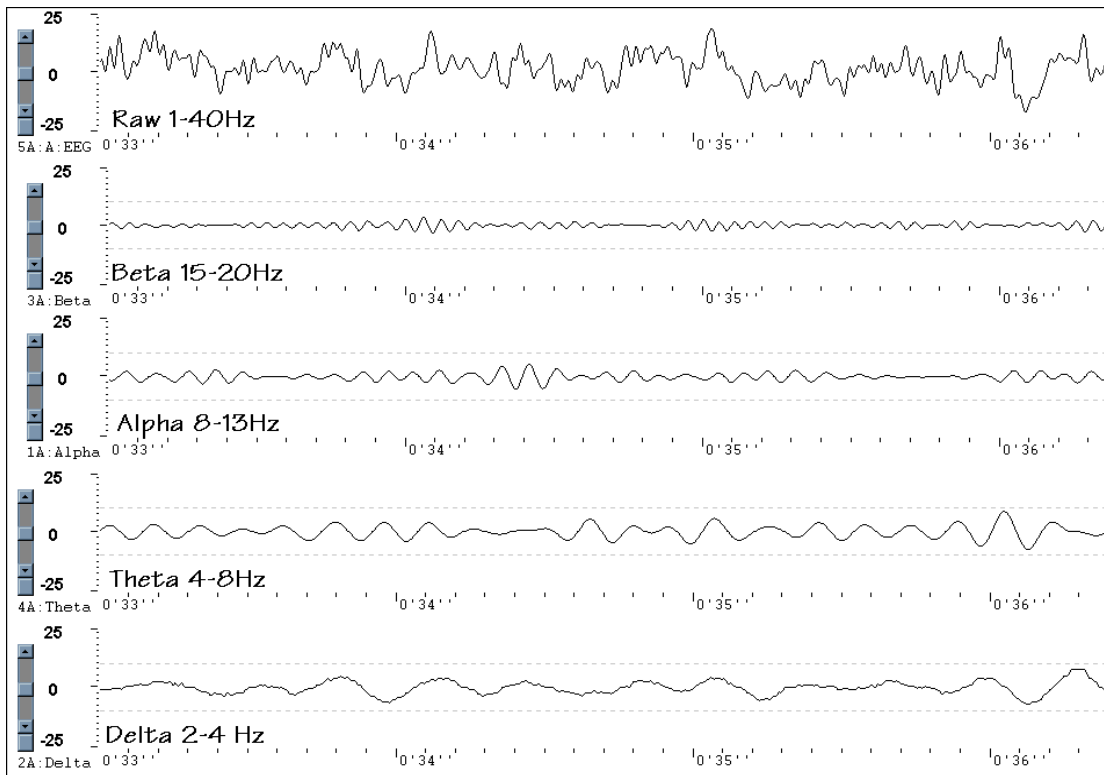



---

# SKIN CONDUCTANCE: SC FLEX/PRO

## Sensor Type

The skin conductance sensor for ProComp Infiniti is called SC-Flex/Pro.

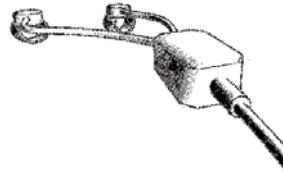

## Operating Principle

Skin conductance is a measure of the skin's ability to conduct electricity. A tiny electrical voltage is applied through two electrodes, usually strapped to two fingers of one hand, in order to establish an electric circuit where the client becomes a variable resistor. The real-time variation in conductance, which is the inverse of the resistance, is calculated. SC represents changes in the sympathetic nervous system. As a person becomes more or less stressed, the skin's conductance increases or decreases proportionally. Skin conductance, galvanic skin response and electro-dermal response (EDR) are different terms for similar physiological measures.

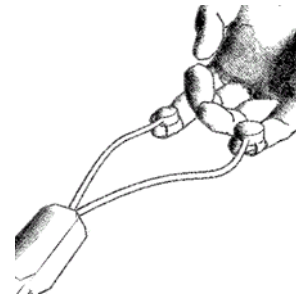

## Measurement Unit

The standard measurement unit for conductance is called Siemens. Skin conductance is measured in micro-Siemens. Some biofeedback systems display skin conductance in micro-mhos ( $\mu\text{m}$ ) - a mho is the inverse of an ohm, which is the measure of resistance. These two measures,  $\mu\text{S}$  and  $\mu\text{m}$ , are equivalent. Normal readings, for skin conductance, in a relaxed state are around  $2 \mu\text{S}$ , but readings can vary greatly with environmental factors and skin type.

## Sensor Placement

The skin conductance sensor has two short leads that extend from the circuit box. At the end of each lead is an electrode snap similar to those on the extender cables. The GSR sensor uses two replaceable electrodes that are sewn inside Velcro straps. The electrode strap must be fastened around a finger tightly enough so the electrode surface is in contact with the finger pad but not so tightly that it limits blood circulation. No conductive paste should be used on the electrodes. Remember to clean the electrodes with an alcohol wipe between clients. These AG/AG/CL electrode snaps should be replaced after about 50 uses or when wear is apparent.

## Typical Signal

The type of signal recorded from a skin conductance sensor shows relatively rapid increases and slower decreases.

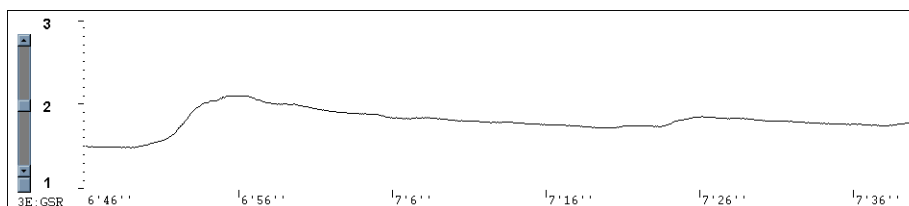



---

# PERIPHERAL TEMPERATURE

## Sensor Type

To measure peripheral skin temperature with the ProComp Infinity device, use the Temp-Flex/Pro sensor.

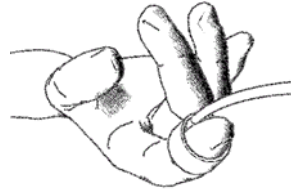

## Operating Principle

The temperature sensor is called a thermistor. This device converts changes in temperature to changes in an electrical current. The body's peripheral temperature, as measured on its extremities, will vary according to the amount of blood perfusing the skin. This, in turn, is dependent on the client's state of sympathetic arousal. As a person gets stressed, their fingers tend to get colder. Relaxation training involves learning to voluntarily increase the finger temperature.

## Measurement Unit

Temperature is measured in degrees Fahrenheit or degrees Celsius.

## Sensor Placement

The temperature sensor can be strapped to the dorsal or palmar side of any finger or toe using the short strip of Velcro that is provided with the sensor. Remember to clean the thermistor bead with an alcohol wipe between clients.

## Typical Signal

Peripheral temperature changes are fairly slow and do not have much amplitude. To monitor temperature changes effectively, it is necessary to have a fairly small vertical scale size.

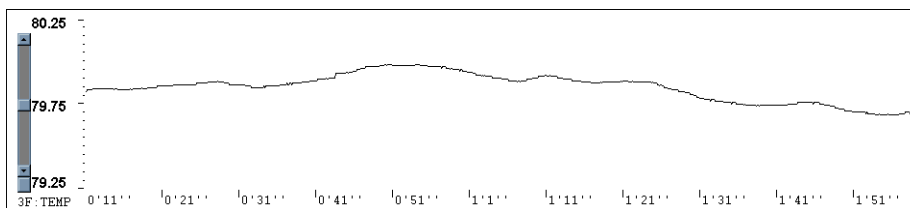

---

# BLOOD VOLUME PULSE

## Sensor Type

To record blood volume pulse (BVP) on the ProComp Infinity, use the BVP-Flex/Pro sensor.

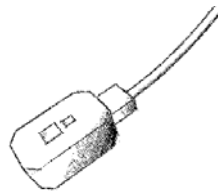

## Operating Principle

BVP, also called photoplethysmography, bounces infra-red light against a skin surface and measures the amount of reflected light. This amount will vary with the amount of blood present in the skin. At each heart beat (pulse), there is more blood in the skin - blood reflects red light and absorbs other colors -

and more light is reflected. Between pulses, the amount of blood decreases and more red light is absorbed. This measure is an indication of vasomotor activity and of sympathetic arousal.

### Measurement Unit

The BVP signal is a relative measure. It does not have a standard unit. From the BVP signal, the software can usually calculate heart rate and inter-beat interval. The amplitude of the BVP deviation can also be a useful measure.

### Sensor Placement

The BVP sensor is held pressed against the palmar surface of a fingertip with an elastic strap (supplied with the sensor) or a small length of adhesive tape. You might have to adjust the pressure on the finger until the maximal signal amplitude is reached. Instruct the client to relax the hand and not to move it, as the sensor is very movement sensitive. Although the sensor is not designed for such placement, some users will tape it to an ear lobe, with double sided adhesive tape.

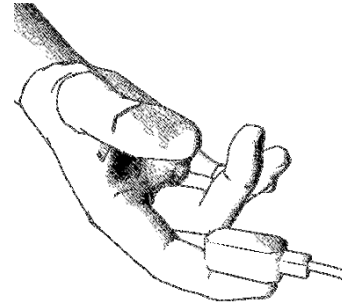

### Typical Signal

The resulting BVP signal shows a typical strong rise with the systolic contraction, followed by a somewhat slower fall. On some people, the signal will also show a bump in the falling signal (dicrotic notch), which corresponds with the pulse of the diastolic contraction. The peak-to-peak amplitude of the signal will increase and decrease with changes in sympathetic arousal.

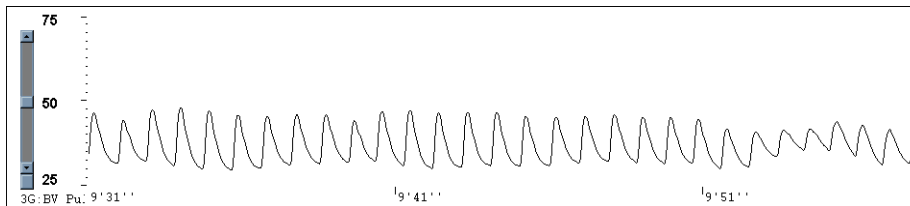

---

## RESPIRATION AMPLITUDE: RESP FLEX/PRO

### Sensor Type

The Respiration sensor is labeled Respiration-Flex/Pro. Although the respiration sensor is frequently called a strain gauge, the Thought Technology sensor does not use an actual strain gauge to measure respiration.

### Operating Principle

The Respiration sensor is sensitive to stretch. When strapped around a client's chest or abdomen, it will convert the expansion and contraction of the rib cage or abdominal area, to a rise and fall of the signal on the screen.

### Measurement Unit

The respiration signal is a relative measure of chest expansion. The ProComp Infiniti does not generate standard units of measure for respiration. From the raw signal waveform, the software is able to calculate the respiration rate and relative breath amplitude. If two sensors are used, it is possible to compute the difference in amplitude of expansion between the thorax and abdomen.

## Sensor Placement

The sensor consists mainly of a long Velcro strap that is stretched around the client's chest or abdomen. When placing the sensor on the client, ask for a full expiration and quickly fasten the strap with just a small amount of tension at that time. The sensor should not be loose when the client breathes out completely. The sensor's rubber tube and circuit box should be placed in the front, as illustrated. The sensor can be placed on top of clothing, if not too bulky. Note: The tube is made of natural rubber and some people may be allergic to rubber. Please verify your client's allergic conditions before using the respiration sensor. When using two sensors, strap one around the client's chest, just above the breasts, and one at the level of the navel. Avoid storing the sensor with the tubing stretched as this will shorten its usable life.

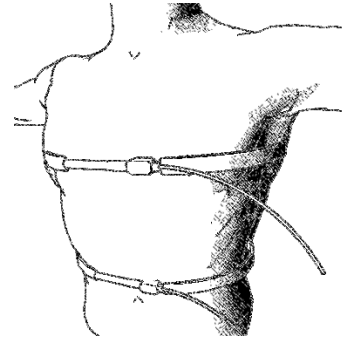

## Typical Signal

There are many breathing patterns that can be recognized, but there is actually no typical waveform for the respiration signal. Commonly, there is a fast rise that slows near the top of the breath and this is followed by a fast fall that slows near the end of the breath. The breathing pattern will alter itself as the person focuses on a task, talks or falls asleep.

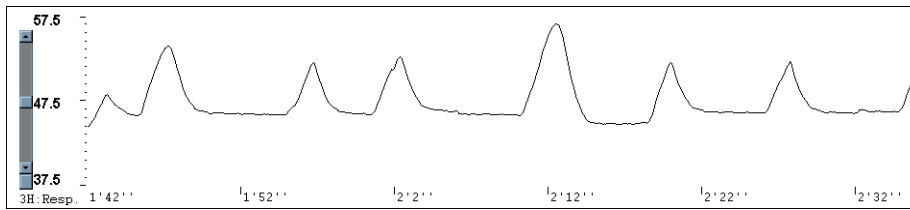

# Self-Calibration

Over long periods of time or when moving between environments with very different temperature ranges self-calibration can increase the accuracy of your device. The encoder contains a built-in voltage reference that possesses good temperature stability and can be used to recalibrate the unit. Each channel's gain and offset will be checked and set to be within the specifications listed at the back of this manual.

## To Perform A Self-Calibration:

- Ensure that the encoder's temperature is stable, and is close to the temperature at which you plan to use it. Since certain parameters exhibit temperature drift, self-calibrating the encoder at or near the temperature at which it is used can cancel out any drift that has occurred from another temperature.
- For best results, replace the batteries if the encoder is showing a low battery warning.
- Unplug all sensors from the encoder, as well as any Compact Flash module.
- Press and hold the power switch for 10 seconds, or until the blue LED blinks quickly in a sequence of 3 flashes. Release the power switch as soon as you see the three flashes. Self-calibration will then be initiated. If you continue to hold the button too long, it will not occur.
- The self-calibration will continue for about 20-30 seconds, at which point the blue LED will stop flashing and light up steadily as before.
- If the blue LED flashes quickly for about 1 second before lighting up steadily, this indicates that the self-calibration failed. If this happens repeatedly when you try to self-calibrate the encoder, return it to the manufacturer for service.

## Notes About Self-Calibration

- Self-calibration requires that all sensors are unplugged from the encoder. Near the start of the self-calibration procedure, the unit will check for plugged-in sensors and abort the operation if they are detected. However, be sure not to plug any sensor into the unit after starting self-calibration. Doing so could result in calibration failure or in poor calibration on the affected channel.
- Keep the encoder several feet from active electronic devices such as computers and monitors, and avoid operating wireless devices near the encoder, while it is performing a self-calibration.
- By depressing and briefly holding the power switch during the calibration, but before it finishes, you can abort the operation. In this case, the new calibration settings will not take effect.
- A successful Self-Calibration exercises most of the signal path of each channel, and gives a high probability that the signal paths are working properly and are properly recalibrated. However it does not exercise the entire signal path under realistic conditions, and of course it does not calibrate the sensors. If a higher degree of assurance is required that the unit is operating as per its original specifications, you may return it and/or the sensors to the manufacturer for a factory recalibration.

# Condition Code Summary

The ProComp Infiniti encoder communicates various conditions to the user by means of flashing its two LEDs. The following table summarizes what these flashes mean.

Encoder Action or Mode	Flash sequence	Interpretation
Normal operation (e.g. just turned on)	BLUE – solid on	Everything normal.
	BLUE – slow flash	Low battery warning: starts when 20 to 30 minutes of battery life remain.
	BLUE – fast flash 1 second, then between 2 and 5 slow flashes (repeated indefinitely)	Internal error. Unit will not function. Return unit for service.
Impedance Check command (hold power switch for 3 seconds), and ongoing Impedance Check.	BLUE – off, then 2 quick flashes (repeated indefinitely)	Impedance Check mode
Self-Calibration command (hold power switch for 10 seconds), and ongoing Self-Calibration	BLUE – off, then 3 quick flashes (repeated while Self-Calibration is occurring)	Self-Calibration mode
Self-Calibration, at end	BLUE – changes to steady on.	Successful self-calibration
	BLUE – fast flashing about 1 second, then steady on.	Failed self-calibration.
Compact Flash – just inserted	WHITE – Long blink (about 1 second), then flashes 1 to 10 times	Compact flash recognized and ready to record, with each flash indicating 10% of remaining capacity (e.g. 4 flashes indicate 40%).
	WHITE – Long on period (about 1 second), then no blinks	Compact flash recognized, but no space left (zero blinks)
	WHITE – Fast flashing (about 1 second), then between 2 and 6 slow flashes. The entire sequence is repeated 3 times.	Compact Flash Error, as follows: 2 flashes: internal error. Return unit for service on Compact Flash function. 3 flashes: Compact Flash detected but not recognized. 4 flashes: Compact Flash not properly formatted. Try reformatting Compact Flash. 5 flashes: Compact Flash format not supported. Format Compact Flash under an earlier format version, or upgrade encoder firmware. 6 flashes: inconsistent format data in Compact Flash. Try reformatting Compact Flash.
Compact Flash Record Command (hold power switch until white LED turns on, about 2 seconds).	WHITE – turns on and stays on as long as button is pressed, then flashes 1 to 10 times.	Recording in process. Each flash indicates 10% of remaining capacity (e.g. 4 flashes indicate 40%)

# Reference

---

## TECHNICAL SUPPORT AND ORDER PLACING

### Returning Equipment

*Be sure to call for an authorization number (RA) before returning any equipment!*

Send the unit(s) **postage prepaid** and **insured**, with proof of purchase to one of the addresses below. If you are shipping from outside Canada or the USA to Canada, mark the package '**Goods to be repaired - Made in Canada**' to avoid unnecessary customs charges.

All customs and duties charges will be billed to you if incurred by sending the unit to the **wrong** address. Provide a **detailed** description of the problem you are experiencing, and your telephone/fax number and email (see form on the last page of this manual).

In the USA, ship insured to:

Thought Technology Ltd.  
Cimetra Industrial Park  
8396 Route 9  
West Chazy, New York  
12992-2718, USA

In Canada and all other countries, contact your dealer or ship insured to:

Thought Technology Ltd.  
2180 Belgrave Avenue  
Montreal, Quebec  
Canada H4A 2L8

---

## TECHNICAL SUPPORT

For technical support please refer to the Thought Technology Ltd website at [www.thoughttechnology.com](http://www.thoughttechnology.com) for frequently asked questions. If your support issue is not covered please e-mail or telephone at the number below.

☎ (514) 489-8251    ✉ [techsupport@thoughttechnology.com](mailto:techsupport@thoughttechnology.com)

# Product Numbers & Accessories

---

## PROCOMP INFINITI ENCODER & SENSORS

SA7500	PROCOMP INFINITI ENCODER
SA7700	TT-USB
T9305M	EEG FLEX/PRO SENSOR
T9305Z	EEG-Z IMPEDANCE CHECKING SENSOR
T9306M	EKG FLEX/PRO SENSOR
SA9308M	BVP-FLEX/PRO BLOOD VOLUME PULSE SENSOR
SA9309M	SC-FLEX/PRO SKIN CONDUCTANCE SENSOR
SA9310M	TEMP-FLEX/PRO TEMPERATURE SENSOR
SA9311M	RESP-FLEX/PRO RESPIRATION SENSOR
T9401M-50	MYOSCAN-PRO EMG SENSOR (50HZ)
T9401M-60	MYOSCAN-PRO EMG SENSOR (60HZ)
SA9503M	MYOSCAN EMG SENSOR
T9405	VOLTAGE ISOLATOR
T9545	GONIOMETER ADAPTER
T9540	FORCE SENSOR ADAPTER

---

## ACCESSORIES

SA9385M	PROTECTED PIN REPLACEMENT SENSOR CABLE
SA9385-96	CABLE, PP SENSOR 96" (144CM)
SA9450	CABLE FIBRE OPTIC 1FT
SA9451	CABLE FIBRE OPTIC 10FT
SA9480	CABLE FIBRE OPTIC 15FT
SA9452	CABLE FIBRE OPTIC 25FT
SA3403	ELECTRODE EXTENDER CABLES (THREE PACK)
SA8950	PRO-SB
SA8952	PRO-SB DUAL
T8720M	SENSOR EXTENDER CABLE (PROTECTED PIN)
T8730	EEG EXTENDER CABLES BIPOLAR
T8725	EEG EXTENDER CABLES MONOPOLAR
T8735	MONOPOLAR LINK EAR EEG 4 LEAD
T8740	EEG EXTENDER CABLE PP TO DIN
T3402M	TRIODE DISPOSABLE ADHESIVE ELECTRODES (X 100)
T3404	SINGLE DISPOSABLE ELECTRODES (X 300)
T3425	UNI-GEL ELECTRODES (X 100)
SA2306	HEADBAND EMG
T3450	EEG PASTE TEN20 114 g / 4 oz
T3470	NUPREP EEG SKIN PREPPING GEL 114 g / 4oz
T3480	ELEFIX ELETRODE GEL 180 g / 6.3 oz
SA5000-14	AQUASENSE SMALL ARM PROTECTOR
SA5000-16	AQUASENSE MEDIUM ARM PROTECTOR
SA5000-18	AQUASENSE LARGE ARM PROTECTOR
SA5010-14	AQUASENSE SMALL LEG PROTECTOR
SA5010-16	AQUASENSE MEDIUM LEG PROTECTOR
SA5010-18	AQUASENSE LARGE LEG PROTECTOR

# Placing Orders

## Outside USA

Tel: (514) 489-8251

Fax: (514) 489-8255

## In USA Toll-Free

Tel: 1-800-361-3651

E-Mail: [mail@thoughttechnology.com](mailto:mail@thoughttechnology.com)



# Specifications

## **MyoScan Pro EMG Sensor (SA9401M)**

Size (Approx.)	37mm x 37mm x 15mm (1.45" x 1.45" x 0.60")
Weight	25g (1 oz)
Input Impedance	1,000,000M $\Omega$ in parallel with 10 pF
Input Range	0 – 400 $\mu$ V <sub>RMS</sub> , 0 – 1600 $\mu$ V <sub>RMS</sub>
Sensitivity	<0.1 $\mu$ V <sub>RMS</sub>
Bandwidth	20Hz – 500Hz
Accuracy	$\pm$ 5%, $\pm$ 0.3 $\mu$ V <sub>RMS</sub>

## **MyoScan EMG Sensor (SA9503M)**

Size (Approx.)	37mm x 37mm x 12mm (1.45" x 1.45" x 0.45")
Weight	15g (0.5 oz)
Input Impedance	$\geq$ 10 <sup>12</sup> $\Omega$ in parallel with 10pF
Input Range	0 – 2000 $\mu$ V <sub>RMS</sub>
Sensitivity	<0.1 $\mu$ V <sub>RMS</sub>
CMRR	>130dB
Channel Bandwidth	10Hz – 1kHz
Signal Output Range	0 – 1.0V <sub>RMS</sub>
Input / Output Gain	500
Supply Voltage	7.26V ( $\pm$ 0.02V)
Current Consumption	0.7mA ( $\pm$ 0.25mA)
Accuracy	$\pm$ 0.3 $\mu$ V <sub>RMS</sub> Plus $\pm$ 4% of reading @25°C to 30°C,

## **EKG Sensor (SA9306M)**

Size (Approx.)	37mm x 37mm x 12mm (1.45" x 1.45" x 0.45")
Weight (approx.)	25g (1oz)
Input Impedance	1,000,000M $\Omega$ in parallel with 10pF
Signal Input Range	0 –12mV <sub>RMS</sub>
Sensitivity	<1 $\mu$ V <sub>RMS</sub>
CMRR	>130dB
Channel Bandwidth	0.05Hz – 1kHz
Signal Output Range	0 – 600mV <sub>RMS</sub>
Input/Output Gain	50
Supply Voltage	7.26V ( $\pm$ 0.05V)
Current Consumption	<1.5mA
Accuracy	$\pm$ 3 $\mu$ V <sub>RMS</sub> , $\pm$ 5% of reading @25°C to 30°C

**EEG-Z Sensor (SA9305Z)**

Size (Approx.)	37mm x 37mm x 12mm (1.45" x 1.45" x 0.45")
Weight (approx.)	25g (1oz)
Input Impedance	10GΩ in parallel with 10pF
Signal Input Range	0 –200μV
Sensitivity	<0.1μV <sub>RMS</sub>
CMRR	>130dB
Channel Bandwidth	2Hz – 1kHz
Accuracy	±0.3μV <sub>RMS</sub> , ±5% of reading @10°C to 40°C

**EEG Sensor (SA9305M)**

Size (Approx.)	37mm x 37mm x 12mm(1.45" x 1.45" x 0.45")
Weight	25g (1 oz)
Input Impedance	1,000,000MΩ in parallel with 10pF
Input Range	0 – 200μV <sub>RMS</sub>
Sensitivity	<0.1μV <sub>RMS</sub>
Bandwidth	2Hz – 1kHz
CMRR	>130dB
Accuracy	±0.3μV <sub>RMS</sub> , ±5% of reading @10°C to 40°C

**Temperature Sensor (SA9310M)**

Length (Approx.)	152cm (60")
Weight	10g (0.33oz)
Temperature Range	10°C - 45°C (50°F – 115°F)
Accuracy	±1.0°C (±1.8°F) 20°C – 40°C (68°F – 104°F)

**HR/BVP Flex/Pro Sensor (SA9308M)**

Length (Approx.)	20mm x 34mm x 10mm (0.72" x 1.33" x 0.41")
Weight	20g (0.66 oz)
Input Range	Unit less quantity displayed as 0% – 100%
Accuracy	±5%

**Respiration Sensor (SA9311M)**

Size (Approx.)	132cm (52" Long)
Weigh	30g (1.0 oz)
Range	30% – 65%

**Voltage Isolator (SA9405)**

Size (Approx.)	95mm x 57mm x 32mm (3.75" x 2.25" x 1.25")
Weight	55g (2 oz)
Input Impedance	1M $\Omega$
Input Range	0 – 200mV, 0 – 2V, 1.952V – 3.648V
Bandwidth	0Hz – 40Hz
Accuracy	$\pm 5\%$ and $\pm 1\text{mV}$ (0 – 200mV range) $\pm 5\%$ and $\pm 10\text{mV}$ (0 – 2V range) $\pm 5\%$ (1.952V – 3.648V range)

**Skin Conductance Flex/Pro Sensor (SA9309M)**

Size without electrode leads (approx.)	3.5 cm (1.4")
Size with electrode leads (approx.)	15 cm (6.0")
Cable Length (approx.)	127 cm (50")
Weight (approx.)	25 g (1 oz)
Signal Input Range	0 – 30.0 $\mu\text{S}$
Accuracy	$\pm 5\%$ and $\pm 0.2 \mu\text{S}$

**ProComp Infiniti Encoder (SA7500)**

Size (approx.)	130mm x 95mm x 37mm (5.1" x 3.7" x 1.5")
Weight (approx.)	200g (7oz)
Power Source	4AA batteries, single use alkaline or NiMh Rechargeable
Supply Voltage	3.6V – 6.5V (fiber optic), minimum 4.0V (Compact Flash)
Battery Life, Alkaline cells	30h typical, 20h minimum
Low-battery warning	20 – 30 minutes of battery life remaining
Sensor supply voltage	7.260V $\pm$ 2mV
ADC output	14bits
Full-scale input range, DC	2.8V $\pm$ 1.696V
LSB magnitude	207uV
Encoder channel bandwidth (3dB) and sample rate	DC – 512Hz @ 2048 samples/second DC – 64Hz @ 256 samples/second DC – 64Hz @ 200 samples/second DC – 8Hz @ 32 samples/second DC – 8Hz @ 20 samples/second
Anti-aliasing Filter	5th order Butterworth
Alias rejection	30dB typical
DC gain accuracy	$\pm$ 0.5% (initial, or after self-calibration)
DC offset	$\pm$ 3LSB (initial, or after self-calibration)
Overall system accuracy	5%
Offset drift, calibration temperature $\pm$ 10C	$\pm$ 5 LSB
Encoder noise	150uV RMS, 1mV p-p typical, offset removed

**NOTE:** PROCOMP INFINITI and its sensors are sensitive electronic instruments and should be handled as such. Be especially careful to avoid both pulling on the electrode cable and getting moisture or electrode gel on the sensor snaps. If necessary, wipe the surface with a damp cloth or use a moistened Q-tip to remove gel from inside the sensor snaps. Wipe with a dry cloth.

# Index

## B

Battery Placement, 10  
blood volume pulse, 25

## C

Cable lengths, 7  
Compact Flash, 10  
Connecting the Encoder Unit, 8  
Connecting the Interface Unit, 8

## E

EEG sensor, 20  
EKG sensor, 19  
Encoder Time, 12  
Encoder Unit  
    Connecting, 8  
    ProComp, 9

## F

Fiber Optic Cab, 15  
Fiber Optic Cable, 8

## I

Interface Unit  
    Connecting, 8

## M

MyoScan, 17  
MyoScan-Pro, 17

## O

Order Placing, 30

## P

PROCOMP  
    Basic package, 7  
ProComp Encoder Setup, 9  
Protected Pins, 14

## R

Recording, 13

**Repair Return Form, 39**

Respiration sensor, 26  
Returning Equipment, 30

## S

Self-Calibration, 28  
Sensor Care, 17  
Sensors, 7  
skin conductance, 24  
skin temperature, 25  
switches, 9

## T

Technical Support, 30  
TT-USB, 7

## W

Warranty, 38

## Z

Zeroing, 18

 **Warranty**

The PROCOMP INFINITI system and all equipment including optional items are guaranteed to be free from defects in material and workmanship for 1 year from the date of purchase.

In the unlikely event that repair is necessary, call Thought Technology Ltd. to receive a Return Authorization. Then send the unit back by a traceable method--Thought Technology will not be responsible for items not received. We will repair or replace your unit(s) free of charge.

This warranty does not apply to damage incurred through accident, alteration, or abuse, nor to sensor damage created by static electricity. Do not use this equipment in dry, static area unless using an anti-static mat or anti-static spray on carpeted areas.

Thought Technology may refuse to honor this warranty if the tamper-evident seal located in the battery compartment is broken.

**IMPORTANT:** Remove dead batteries promptly to prevent corrosion damage.

**Optional Extended Warranty**

Please contact Thought Technology Ltd. for further details.



# Repair Return Form

**Be sure to call for authorization before returning any equipment!**

Remove or copy this form and include it with the unit(s).

Include copy of original invoice and return to the address in the Returning Equipment section.

Name \_\_\_\_\_

Company \_\_\_\_\_

Address \_\_\_\_\_

\_\_\_\_\_

\_\_\_\_\_

Phone No. \_\_\_\_\_

Fax No. \_\_\_\_\_

Date Purchased \_\_\_\_\_

From Whom \_\_\_\_\_

Model Name \_\_\_\_\_

Serial Number \_\_\_\_\_

\_\_\_\_\_

\_\_\_\_\_

Problem \_\_\_\_\_

\_\_\_\_\_

\_\_\_\_\_

\_\_\_\_\_

\_\_\_\_\_

# Infiniti hardware Copyright Notice

This hardware contains proprietary embedded software code, which is the property of Thought Technology Ltd.; it is provided under a license agreement containing restrictions on use and disclosure and is also protected by copyright law. Reverse engineering of the software or the resulting output data stream is prohibited.

Due to continued product development the embedded software may change without notice. The information and intellectual property contained herein is confidential between Thought Technology Ltd. and the client and remains the exclusive property of Thought Technology Ltd. If you find any problems in the documentation, please report them to us in writing. Thought Technology Ltd. does not warrant that this document is error-free.

No part of this publication may be reproduced, stored in a retrieval system, or transmitted in any form or by any means, electronic, mechanical, photocopying, and recording or otherwise without the prior written permission of Thought Technology Ltd.

ProComp-Infiniti™, FlexComp-Infiniti™, BioGraph®, are trademarks of Thought Technology Ltd.  
© copyright Thought Technology 2003

---