

# Mitsubishi General-Purpose Programmable Controller Renewal Tool

## Conversion Adapter Model ERNT-ASQTD62

## User's Manual



50CM-D180122-C(1409)

**MITSUBISHI ELECTRIC ENGINEERING COMPANY LIMITED**  
 HEAD OFFICE: HULIC KUDAN BLDG.1-13-5, KUDANKITA CHIYODA-KU, TOKYO 102-0073, JAPAN  
 NAGOYA ENGINEERING OFFICE: 139 SHIMOYASHIKI-CHO SHIMOYASHIKI, KASUGAI, AICHI 486-0906, JAPAN

### SAFETY PRECAUTIONS

(Always read these precautions prior to use.)

Before using this product, please read this manual carefully and pay full attention to safety to ensure that the product is used correctly. The precautions presented in this manual are concerned with this product only. For Programmable Controller system safety precautions, refer to the user's manual of the MELSEC-Q series CPU module to be used. In this manual, the safety precautions are ranked as "WARNING" and "CAUTION."

**WARNING** Indicates that incorrect handling may cause hazardous conditions, resulting in death or severe injury.

**CAUTION** Indicates that incorrect handling may cause hazardous conditions, resulting in medium or minor injury and/or property damage.

Note that failure to observe the CAUTION level instructions may lead to a serious consequence according to the circumstances. Always follow the precautions of both levels because they are important to personal safety. Please keep this manual in an easy-to-access location for future reference, and be sure to provide the manual to the end user.

### Precautions before using

**CAUTION**

- When making a switch from the MELSEC-AnS Series to the MELSEC-Q Series, be sure to consult user's manual supplied with individual module under the MELSEC-Q Series to confirm differences in various aspects including performance and function between the two series.

### Installation Precautions

**CAUTION**

- Use the Conversion Adapter in the environmental conditions that are specified in the general specification. If the Products are used in any environment beyond the bounds of the general specification, electric shock, fire, malfunction, or damage to or degradation of the Products will result.
- Do not directly touch any conductive parts of Conversion Adapter. Contact will cause malfunction or failure in the system.
- Fasten the Conversion Adapter and the Mounting Bracket securely with retaining screws, and tighten the screws by applying torque within specified limits. Loose screws can lead to the dropping of the Conversion Adapter or Mounting Bracket, possibly causing breakage thereof. Excessive tightness of the screws can lead to breakage of the screws, Conversion Adapter, Mounting Bracket, or MELSEC-Q Series Module, possibly causing the dropping, shorting, and malfunction thereof.
- Always check for correct match between MELSEC-Q Series and the Conversion Adapter. Incorrect match can cause damage to the MELSEC-Q Series Module.
- When installing the Conversion Adapter, take care not to get your hand snagged on the Mounting Bracket or the like. Injury may result.
- When installing or removing the MELSEC-Q Series Module complete with a Converter Adapter, be sure to hold it with both hands. Dropping may lead to breakage.

### Wiring Precautions

**WARNING**

- Before attempting to install the Unit or carry out the necessary wiring, make certain that the external power supply, used in the system, is shut off on all three phases. Failure to do so may result in electric shock or damage to the product.
- After installation and wiring, close the terminal block cover before turning on the module for operation. Failure to do so may result in electric shock.

### Wiring Precautions

**CAUTION**

- Carry out wiring for the Conversion Adapter correctly after checking the specification and terminal arrangement for the module used. Connecting a power supply with a different voltage rating or incorrect wiring may cause a fire or failure.
- Tighten the MELSEC-AnS Series terminal installation screws and terminal screw securely by applying torque within the specified limits. Loose screws will cause short circuit, fire or malfunction. Excessive tightening will damage the screws or the Conversion Adapter which in turn will cause dropping of parts, short circuit or malfunction.
- Use care to prevent foreign materials including cuttings and wiring debris from entering the Conversion Adapter or the MELSEC-Q Series Module. These will be cause for fire, failure or malfunction.

### Startup and Maintenance Precautions

**WARNING**

- Do not touch live terminals. There is a danger of electric shock or malfunction.
- Shut off the external power supply for the system in all phases before cleaning or retightening the terminal screws. Failure to do so may result in electric shock or cause the MELSEC-Q Series module to fail or malfunction. Loose screws can lead to dropping, shorting, and malfunction. Excessive tightness of the screws can lead to breakage of the screws, Conversion Adapter, Mounting Bracket, or MELSEC-Q Series Module, possibly causing the dropping, shorting, and malfunction thereof.

### CAUTION

- Do not modify the Conversion Adapter or take it apart. Doing so will cause failure, malfunction, personal injury, or fire.
- Do not drop the Conversion Adapter and Mounting Bracket or do not give a strong impact to it. This will cause damage.

### Disposal Precautions

**CAUTION**

- When disposing of the product, treat it as industrial waste.

### EMC AND LOW VOLTAGE DIRECTIVES

Compliance to the EMC Directive, which is one of the EU Directives, has been a legal obligation for the products sold in European countries since 1996 as well as the Low Voltage Directive since 1997. Manufacturers who recognize their products are compliant to the EMC and Low Voltage Directives are required to declare that print a "CE mark" on their products.

### Authorized representative in Europe

Authorized representative in Europe is shown below.  
 Name: Mitsubishi Electric Europe BV  
 Address: Gothaer strasse 8, 40880 Ratingen, Germany

## 1. Overview

This manual provides information about the Conversion Adapter "ERNT-ASQTD62" available as Renewal Tools for the Mitsubishi General-Purpose Programmable Controller. The Conversion Adapter is a product for effecting conversion to transcend difference in pin assignment between the MELSEC-AnS Series and the MELSEC-Q Series. Before attempting to make a switch from MELSEC-AnS Series to MELSEC-Q Series in your installation, consult the user's manual supplied with individual module under the latter series to learn about how they differ in various aspects including performance and function.

Once you have opened the packaging, verify that it contains the following products.

Product	Quantity
Conversion Adapter	1
Mounting bracket	1
Mounting bracket fixing screw (M2.6×4)	2
Fixture installation screw (M3×8)	1
Terminal block cover	1
Short bar (spare parts)	1

## 2. General Specifications

Item	Specifications
Operating ambient temperature	0 to 55°C (Maximum surrounding air temperature 55°C)
Storage ambient temperature	-25 to 75°C
Operating ambient humidity	5 to 95%RH, non-condensing
Storage ambient humidity	
Vibration resistance	Compliant with JIS B 3502 and IEC 61131-2 Under intermittent vibration: 5 to 8.4Hz, 8.4 to 150Hz, 9.8m/s <sup>2</sup> , 3.5mm Under continuous vibration: 5 to 8.4Hz, 8.4 to 150Hz, 4.9m/s <sup>2</sup> , 1.75mm 10 times each in X, Y, Z directions
Shock resistance	Compliant with JIS B 3502 and IEC 61131-2 (147 m/s <sup>2</sup> , 3 times each in 3 directions X, Y, Z)
Operating atmosphere	No corrosive gases
Operating altitude *1	0 to 2000m
Installation location	Inside a control panel
Ovenvoltage category *2	II or less
Pollution degree *3	2

\*1 : Do not use or store under pressure higher than the atmospheric pressure of altitude 0m.  
 \*2 : This indicates the section of the power supply to which the equipment is assumed to be connected between the public electrical power distribution network and the machinery within premises.  
 Category II applies to equipment for which electrical power is supplied from fixed facilities.  
 \*3 : This index indicates the degree to which conductive material is generated in the environment in which the equipment is used.  
 Pollution level 2 is when only non-conductive pollution occurs. A temporary conductivity caused by condensing must be expected occasionally.

## 3. Product Specifications

For detail specifications which do not appear in the specification comparison charts contained herein, see the user's manual supplied with the MELSEC-Q Series module you use. Those parts of the specification that differ between the MELSEC-AnS Series and the MELSEC-Q Series are where a switch from the first series to the second is subjected to specification-related restrictions. Check the specification of the devices to be connected for more details.

Furthermore, it is recommended to refer to the "Transition from MELSEC-AnS/QnAS (Small Type) Series to Q Series Handbook (Intelligent Function Modules): L (NA)-08220ENG" issued by Mitsubishi Electric.

Conversion Adapter Model	MELSEC-AnS Series Model	No. of channels	MELSEC-Q Series Model	Conversion Adapter Weight (g)
ERNT-ASQTD62	A1SD62	2 channels	QD62	110
	A1SD62E	2 channels	QD62E	

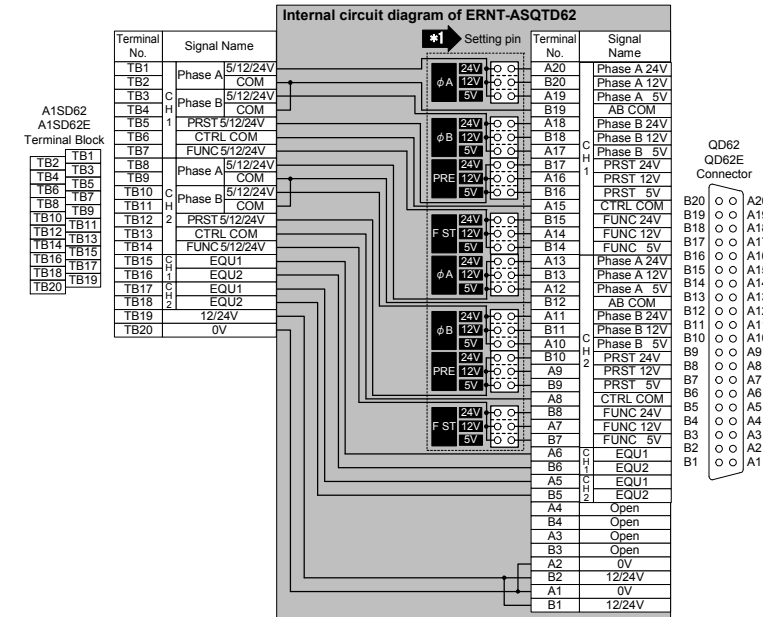

### Precautions for wiring

**\*1** Set the pins of each signal (φA, φB, PRE, F, ST) according to the input voltage. The default input voltage for all signals is 24V (24V side).

24V Input: set to 24V side  
 12V Input: set to 12V side  
 5V Input: set to 5V side

Inputting a voltage higher than the one set using the setting pins may cause a failure in the MELSEC-Q Series module.

### < Specification comparison >

Specification	Model	MELSEC-AnS Series		MELSEC-Q Series		
		A1SD62 A1SD62E	A1SD62E	QD62 QD62E	QD62	QD62E
Counting speed switch settings		Switch with the setting pins		Switch with the intelligent function module switch setting		
		100k	10k	200k (100k to 200kPPS)	100k (10k to 100kPPS)	10k (10kPPS or less)
Number of channels		2 channels				
Count input signal	Phase	1-phase input, 2-phase input		1-phase input (1 multiple/2 multiples), 2-phase input (1 multiple/2 multiples/4 multiples), CW/CCW input		
	Signal level (φA, φB)	5/12/24VDC 2 to 5mA				
Counting speed (max)	1-phase input	100kPPS	10kPPS	200kPPS *1	100kPPS *1	10kPPS *1
	2-phase input	100kPPS	7kPPS			
Counting range		24-bit binary (0 to 16777215)		32-bit signed binary (-2147483648 to 2147483647)		
Counter	Model	UP/DOWN Preset counter + Ring counter function				
	Minimum count pulse width (Duty ratio 50%)					
Coincidence output	Comparison range	24-bit binary		32-bit signed binary		
	Comparison result	Set value < Count value, Set value = Count value, Set value > Count value				
External input	Preset	5/12/24VDC 2 to 5mA				
	Function start					

Specification	Model	MELSEC-AnS Series		MELSEC-Q Series	
		A1SD62	A1SD62E	QD62	QD62E
External output	Coincidence output	Transistor (sinking type) output 12/24VDC 0.5A/point 2A/common		Transistor (sinking type) output 12/24VDC 0.5A/point 2A/common	
I/O occupied points		32 points		16 points	
Wiring connection system		20 point terminal block			
Internal current consumption (5VDC)		0.1A		0.30A	0.33A

Make sure the section of the above table meets the specification of the machines and equipment connected to the MELSEC-Q Series module.

\*1: Counting speed is affected by pulse rise and fall time. Possible counting speeds are shown in the following table. Note that if a pulse that has a large rise and/or fall time is counted, a miscount may occur.

Counting speed switch settings	Both 1-phase and 2-phase input		
	200k	100k	10k
Rise/fall time			
t = 1.25µs or less	200kPPS	100kPPS	10kPPS
t = 2.5µs or less	100kPPS	100kPPS	10kPPS
t = 25µs or less	—	10kPPS	10kPPS
t = 500µs	—	—	500PPS

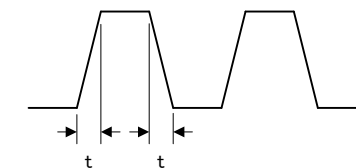

### Precautions for the program

- A1SD62/A1SD62E and QD62/QD62E differ from each other in the way input/output signals (X, Y) and buffer memory addresses are allocated. Therefore, you need make necessary changes to the sequence program that is used.
- Set the counting speed using the intelligent function module switch setting in the QD62 and QD62E instead of the setting pins that are used in the A1SD62 and A1SD62E.

## 4. Mounting and Installation

### 4.1 Handling Precautions

- Before attempting to install the Unit or carry out the necessary wiring, make certain that the external power supply, used in the system, is shut off on all three phases. Failure to do so may result in electric shock or damage to the product.
- Do not touch live terminals. There is a danger of electric shock or malfunction.
- Do not modify the Conversion Adapter or take it apart. Doing so will cause failure, malfunction, personal injury, or fire.
- Do not touch the energized part of the Conversion Adapter directly. Contact will cause malfunction or failure in the system.
- The protective wrap is used to protect your hands from touching the conductive part in the pin-setting process. Peel it off after finishing the settings. In addition, make sure to peel it off before installing a MELSEC-AnS Series terminal block.
- Fasten the Conversion Adapter and the Mounting bracket securely with retaining screws, and tighten the screws by applying torque within specified limits. Loose screws can lead to the dropping of the Conversion Adapter, or Mounting bracket, possibly causing breakage thereof. Excessive tightness of the screws can lead to breakage of the screws, Converter Adapter, Mounting bracket or MELSEC-Q Series Module, possibly causing the dropping, shorting, and malfunction thereof.
- Use care to prevent foreign materials including cuttings and wiring debris from entering the Conversion Adapter or the MELSEC-Q Series Module. These will be cause for fire, failure or malfunction.
- Do not drop the Conversion Adapter and Mounting Bracket or do not give a strong impact to it. This will cause damage.

### 4.2 Use Precautions

Item	Use Precautions
Width dimension of module	<p>Because the module is reduced in width dimension (34.5mm→27.4mm) and thus in area available for wiring, check dimensional data before installing the module.</p> <p>&lt;MELSEC-AnS Series&gt;      &lt;MELSEC-Q Series&gt;</p> <p>34.5mm      27.4mm</p>
Depth and Height dimension	<p><b>Installation with the Base Adapter</b></p> <p>Because the module is increased in depth dimension, check dimensional data before installing the module.</p> <p>MELSEC-AnS Series      MELSEC-Q Series</p> <p>110mm      47.5mmUP      157.5mm</p> <p>Conversion Adapter      Base Adapter</p> <p><b>Installation with the DIN rail</b></p> <p>Because the module is increased in depth and height dimension, check dimensional data before installing the module.</p> <p>MELSEC-AnS Series      MELSEC-Q Series</p> <p>106mm      4mm      66mm      44.5mmUP      150.5mm      69mm</p> <p>Conversion Adapter      Conversion Adapter      Conversion Adapter      Conversion Adapter      DIN rail mounting bracket</p>
Terminal block cover	<p>The terminal block cover for MELSEC-AnS Series is bigger than the width of the MELSEC-Q Series Module. Therefore, it is necessary to replace it with the terminal block cover supplied with the converter adapter.</p> <p>&lt;MELSEC-AnS Series&gt;      &lt;MELSEC-Q Series&gt;</p> <p>Terminal block cover for the MELSEC-AnS Series      Replace the terminal block cover with the one supplied with the Conversion Adapter.</p> <p>34.5mm      27.4mm</p>

### 4.3 Installation Environment

For details of the installation environment, refer to the user's manual of the MELSEC-Q series CPU module to be used.

## 5. Preparation before Installation

### 5.1 Position of the setting pins

Open the cover of the Conversion Adapter, and you will find the setting pins to switch the input signal voltage.

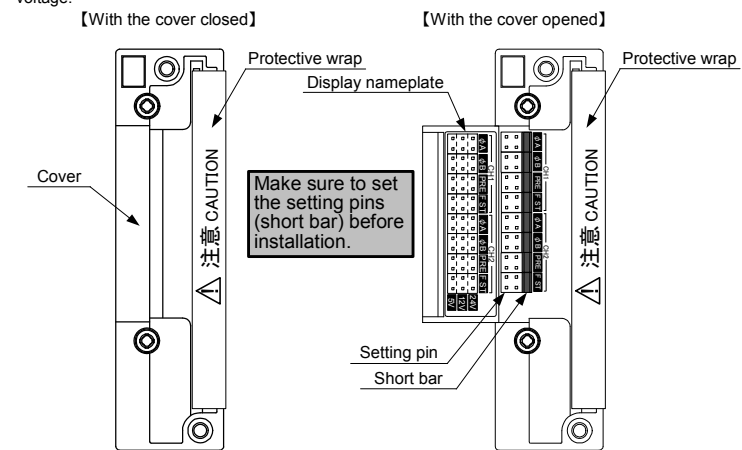

Setting pin	Description	Factory setting	
CH1	$\phi A$	Set the input voltage for A-phase pulse of CH1.	24V
	$\phi B$	Set the input voltage for B-phase pulse of CH1.	
	PRE	Set the input voltage for Preset input of CH1.	
	F ST	Set the input voltage for Function start input of CH1.	
CH2	$\phi A$	Set the input voltage for A-phase pulse of CH2.	
	$\phi B$	Set the input voltage for B-phase pulse of CH2.	
	PRE	Set the input voltage for Preset input of CH2.	
	F ST	Set the input voltage for Function start input of CH2.	

### About the protective wrap

It is used to protect your hands from touching the conductive part in the pin-setting process.

- Peel it off after finishing the settings.
- Make sure to peel it off before installing a MELSEC-AnS Series terminal block.

### 5.2 How to set the setting pins

Set the input voltage for each signal using the short bar. The short bar can be installed from any direction.

Signal	Input	5V	12V	24V (Factory setting)
CH1	$\phi A$			
	$\phi B$			
	PRE			
	F ST			
CH2	$\phi A$			
	$\phi B$			
	PRE			
	F ST			

### Notice

Incorrectly setting the setting pins will cause a failure and malfunction. Make sure to set them correctly.

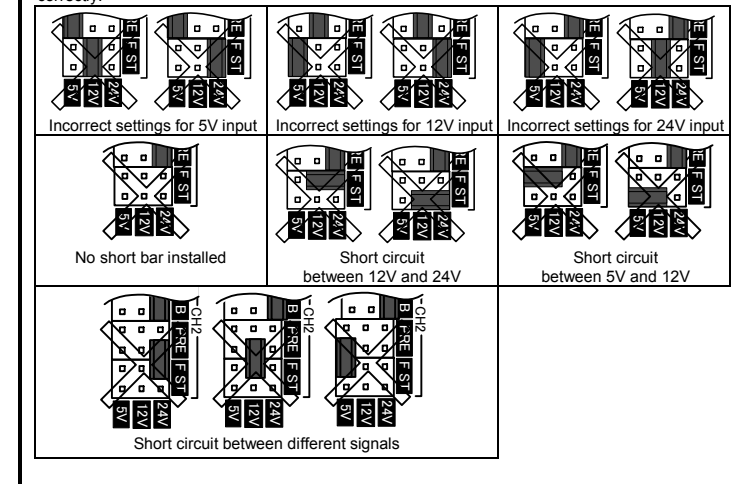

## 5.3 Procedure

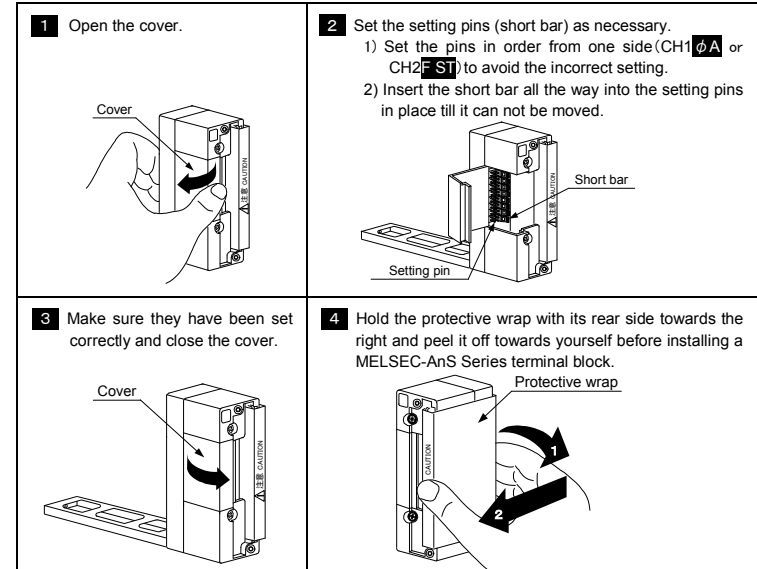

## 6. Part Names and Installation Method

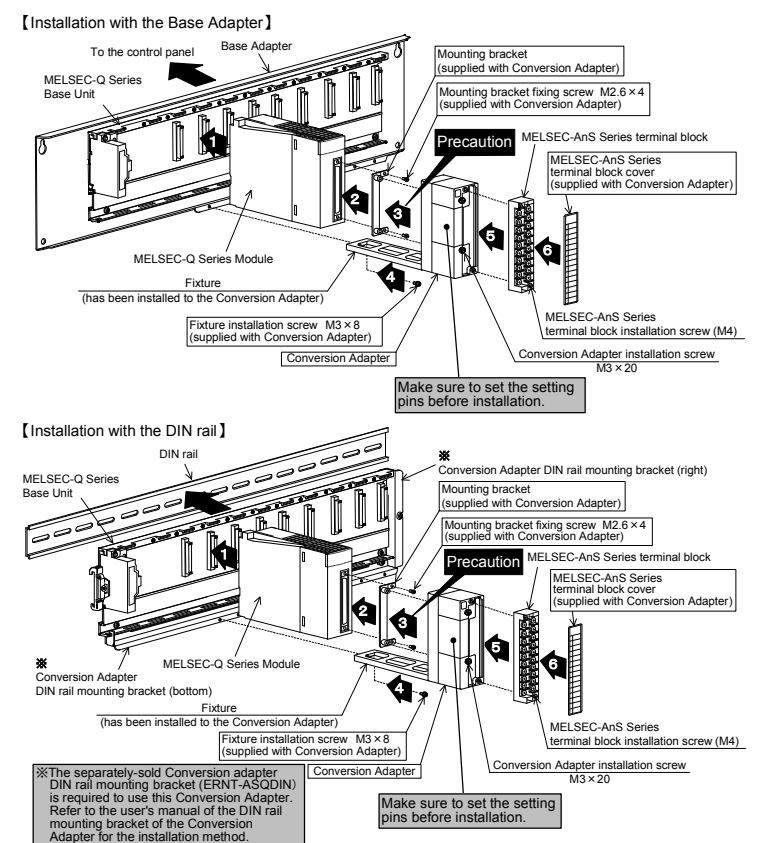

### 6.1 Installation Method

Installation with the Base Adapter	Installation with the DIN rail
Mount the MELSEC-Q Series Base Unit to the Base Adapter. Refer to the Base Adapter's manual for how to install them to the control panel.	Mount the MELSEC-Q Series Base Unit to the DIN rail mounting bracket of the Conversion Adapter and the adapters for DIN rail installation manufactured by Mitsubishi Electric. For how to mount them to the DIN rail, refer to the user's manual of the Conversion Adapter DIN rail mounting bracket and QCPU.

- Mount the MELSEC-Q Series module to the MELSEC-Q Series Base Unit.
  - Secure the Mounting Bracket to a compatible module under the MELSEC-Q Series with Mounting Bracket fixing screws (M2.6 x 4). (2 places)
  - Install the Conversion Adapter to the MELSEC-Q Series module, and secure it with the Conversion Adapter installation screws (M3x20). (2 places)
- Precaution**
- Before tightening the installation screws, check that the Conversion Adapter has been securely installed on the MELSEC-Q Series module. Tightening the screws in floating-off state or tilting state will damage the Conversion Adapter installation screws and the mounting bracket.
- Secure the fixture to the Base Adapter or Conversion Adapter DIN rail mounting bracket (bottom) of the Conversion Adapter with fixture installation screws (M3 x 8). (1 place)
  - Secure the MELSEC-AnS Series terminal block to the Conversion Adapter with the supplied terminal block installation screw (M4). (2 places, top and bottom.)
  - Remove the terminal block cover from the MELSEC-AnS Series terminal block and fit the terminal block cover supplied with the Conversion Adapter in place.

## 6.2 Tightening Torque

Tighten the module installation screws to the specified torque below. An inappropriate tightening torque could cause the product to fall or result in a short circuit, product failure or malfunction.

Screw Location	Tightening Torque Range
Mounting bracket fixing screw (M2.6x4)	0.20 to 0.29N·m
Conversion Adapter installation screw (M3x20)	0.43 to 0.57N·m
Fixture installation screw (M3x8)	0.61 to 0.82N·m
MELSEC-AnS Series terminal block installation screw (M4 screw)	0.78 to 1.18N·m

## 7. External Dimensions

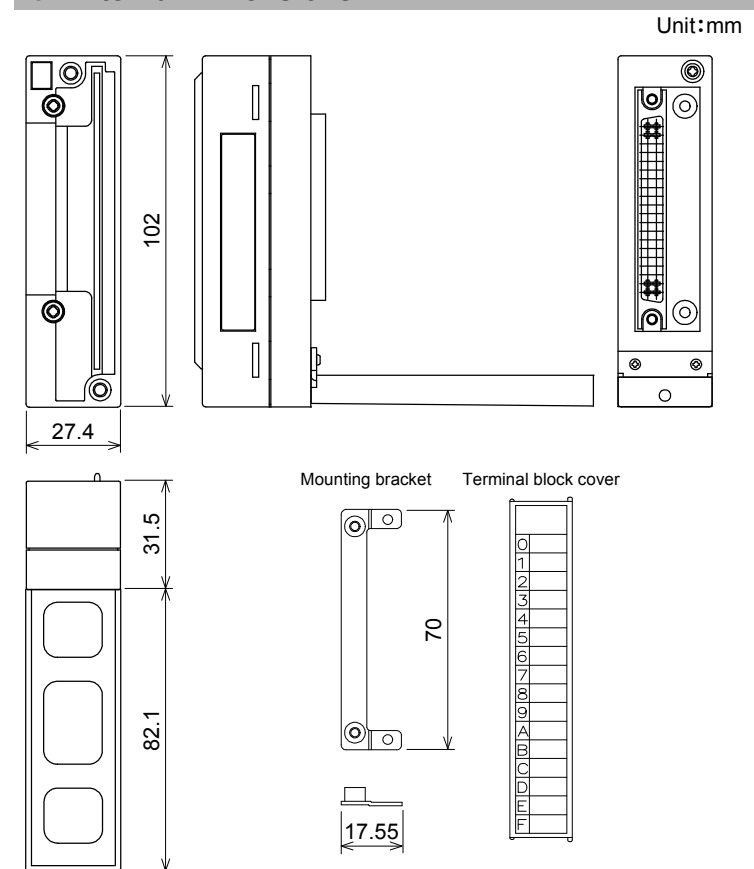

## Product Warranty Details

Please confirm the following product warranty details prior to product use.

### Gratis Warranty Terms and Gratis Warranty Range

If any fault or defect (hereinafter referred to as "Failure") attributable to Mitsubishi Electric Engineering Company Limited (hereinafter referred to as "MEE") should occur within the gratis warranty period, MEE shall repair the product free of charge via the distributor from whom you made your purchase.

### Gratis Warranty Period

The gratis warranty period of this product shall be one (1) year from the date of purchase or delivery to the designated place.

Note that after manufacture and shipment from MEE, the maximum distribution period shall be six (6) months, and the gratis warranty period after manufacturing shall be limited to eighteen (18) months.

In addition, the gratis warranty period for repaired products shall not exceed the gratis warranty period established prior to repair.

### Gratis Warranty Range

The gratis warranty range shall be limited to normal use based on the usage conditions, methods and environment, etc., defined by the terms and precautions, etc., given in the instruction manual, user's manual and caution labels on the product.

### Warranty Period after Discontinuation of Production

- MEE shall offer product repair services (fee applied) for seven (7) years after production of the product has been discontinued. Discontinuation of production shall be reported via distributors.
- Product supply (including spare parts) is not possible after production has been discontinued.

### Exclusion of Opportunity Loss and Secondary Loss from Warranty Liability

Regardless of the gratis warranty period, MEE shall not be liable for compensation for damages arising from causes not attributable to MEE, opportunity losses or lost profits incurred by the user due to Failures of MEE products, damages or secondary damages arising from special circumstances, whether foreseen or unforeseen by MEE, compensation for accidents, compensation for damages to products other than MEE products, or compensation for other work carried out by the user.

### Changes in Product Specifications

The specifications given in the catalogs, manuals and technical documents are subject to change without notice.

This document is a new publication, effective September 2014. Specifications are subject to change without notice.