

Comfort Glow[®]

PREMIUM AGED SPLIT OAK AND YELLOW FLAME UNVENTED (VENT-FREE) NATURAL GAS LOG HEATERS

Also Design-Certified As Vented Decorative Appliances When
Not Used With Hand-Held Thermostat Remote

OWNER'S OPERATION AND INSTALLATION MANUAL

CGD3924NRA
CCL3924NR
CCL3930NR

24" and 30"
Remote Ready

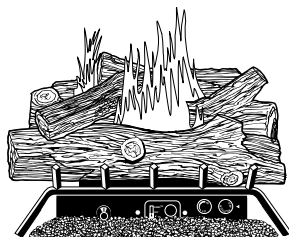

(Yellow Flame Model Shown)

WARNING: If the information in this manual is not followed exactly, a fire or explosion may result causing property damage, personal injury, or loss of life.

- Do not store or use gasoline or other flammable vapors and liquids in the vicinity of this or any other appliance.
- **WHAT TO DO IF YOU SMELL GAS**
 - Do not try to light any appliance.
 - Do not touch any electrical switch; do not use any phone in your building.
 - Immediately call your gas supplier from a neighbor's phone. Follow the gas supplier's instructions.
 - If you cannot reach your gas supplier, call the fire department.
- Installation and service must be performed by a qualified installer, service agency, or the gas supplier.

WARNING: Improper installation, adjustment, alteration, service, or maintenance can cause injury or property damage. Refer to this manual for correct installation and operational procedures. For assistance or additional information consult a qualified installer, service agency, or the gas supplier.

WARNING: This appliance is for installation only in a solid-fuel burning masonry or UL127 factory-built fireplace, or in an approved ventless firebox. It is design-certified for these installations in accordance with ANS Z21.11.2. Exception: Do not install this appliance in a factory-built fireplace that includes instructions stating it has not been tested or should not be used with unvented gas logs.

WARNING: This is an unvented gas-fired heater. It uses air (oxygen) from the room in which it is installed. Provisions for adequate combustion and ventilation air must be provided. Refer to *Air for Combustion and Ventilation* section on page 4 of this manual.

This appliance may be installed in an aftermarket,* manufactured (mobile) home, where not prohibited by local codes.

This appliance is only for use with the type of gas indicated on the rating plate. This appliance is not convertible for use with other gases.

* Aftermarket: Completion of sale, not for purpose of resale, from the manufacturer

Save this manual for future reference.

UNVENTED NATURAL GAS LOG HEATER

SAFETY INFORMATION



WARNINGS

IMPORTANT: Read this owner's manual carefully and completely before trying to assemble, operate, or service this heater. Improper use of this heater can cause serious injury or death from burns, fire, explosion, electrical shock, and carbon monoxide poisoning.

⚠ DANGER: Carbon monoxide poisoning may lead to death!

Carbon Monoxide Poisoning: Early signs of carbon monoxide poisoning resemble the flu, with headaches, dizziness, or nausea. If you have these signs, the heater may not be working properly. **Get fresh air at once!** Have heater serviced. Some people are more affected by carbon monoxide than others. These include pregnant women, people with heart or lung disease or anemia, those under the influence of alcohol, and those at high altitudes.

Natural Gas: Natural gas is odorless. An odor-making agent is added to the gas. The odor helps you detect a gas leak. However, the odor added to the gas can fade. Gas may be present even though no odor exists.

Make certain you read and understand all warnings. Keep this manual for reference. It is your guide to safe and proper operation of this heater.

⚠ WARNING: Any change to this heater or its controls can be dangerous.

⚠ WARNING: Do not allow fans to blow directly into the fireplace. Avoid any drafts that alter burner flame patterns. Ceiling fans can create drafts that alter burner flame patterns. Altered burner patterns can cause sooting.

⚠ WARNING: Do not use a blower insert, heat exchanger insert, or other accessory not approved for use with this heater.

Due to high temperatures, the appliance should be located out of traffic and away from furniture and draperies.

Do not place clothing or other flammable material on or near the appliance. Never place any objects on the heater.

Heater base assembly becomes very hot when running heater. Keep children and adults away from hot surface to avoid burns or clothing ignition. Heater will remain hot for a time after shut-down. Allow surface to cool before touching.

Carefully supervise young children when they are in the room with heater. When using the handheld remote accessory, keep selector switch in the OFF position to prevent children from turning on burners with remote.

You must operate this heater with a fireplace screen in place. Make sure fireplace screen is closed before running heater.

Keep the appliance area clear and free from combustible materials, gasoline, and other flammable vapors and liquids.

1. This appliance is only for use with the type of gas indicated on the rating plate. This appliance is not convertible for use with other gases.
2. If you smell gas
 - shut off gas supply
 - do not try to light any appliance
 - do not touch any electrical switch; do not use any phone in your building
 - immediately call your gas supplier from a neighbor's phone. Follow the gas supplier's instructions
 - if you cannot reach your gas supplier, call the fire department
3. This heater shall not be installed in a bedroom or bathroom unless installed as a vented appliance (see *Installing Damper Clamp Accessory*, page 10).

4. Before installing in a solid fuel burning fireplace, the chimney flue and firebox must be cleaned of soot, creosote, ashes, and loose paint by a qualified chimney cleaner. Creosote will ignite if highly heated. Inspect chimney flue for damage. If damaged, operate heater with flue damper closed.
5. If fireplace has glass doors, never operate this heater with glass doors closed. If you operate heater with doors closed, heat buildup inside fireplace will cause glass to burst. Also if fireplace opening has vents at the bottom, you must open the vents before operating heater.
6. This log heater is designed to be smokeless. If logs ever appear to smoke, turn off heater and call a qualified service person. *Note:* During initial operation, slight smoking may occur due to log curing and heater burning manufacturing residues.
7. To prevent the creation of soot, follow the instructions in *Cleaning and Maintenance*, page 18.
8. Before using furniture polish, wax, carpet cleaner, or similar products, turn heater off. If heated, the vapors from these products may create a white residue within burner box or on adjacent walls or furniture.
9. This heater needs fresh, outside air ventilation to run properly. This heater has an Oxygen Depletion Sensing (ODS) safety shutoff system. The ODS shuts down the heater if not enough fresh air is available. See *Air for Combustion and Ventilation*, pages 4 through 6. If heater keeps shutting off, see *Troubleshooting*, pages 19 through 21.
10. Do not run heater
 - where flammable liquids or vapors are used or stored
 - under dusty conditions
11. Do not use this heater to cook food or burn paper or other objects.
12. Do not use heater if any part has been exposed to or under water. Immediately call a qualified service technician to inspect the room heater and to replace any part of the control system and any gas control which has been under water.
13. Do not operate heater if any log is broken. Do not operate heater if a log is chipped (dime-sized or larger).

SAFETY INFORMATION

Continued

14. Turn heater off and let cool before servicing, installing, or repairing. Make sure the remote selector switch is in the OFF position. Only a qualified service person should install, service, or repair heater.
15. Make sure the remote selector switch is in the OFF position when you are away from home for long periods of time.
16. This heater must not be connected to any external electrical source.
17. Operating heater above elevations of 4,500 feet may cause pilot outage.

LOCAL CODES

Install and use heater with care. Follow all local codes. In the absence of local codes, use the latest edition of *The National Fuel Gas Code, ANS Z223*, also known as NFPA 54*.

*Available from:

American National Standards Institute, Inc.
1430 Broadway
New York, NY 10018

National Fire Protection Association, Inc.
Batterymarch Park
Quincy, MA 02269

Note: Where listed vented decorative logs are required, thermostat operation is not permitted.

UNPACKING

CAUTION: Do not remove the metal data plates attached to the heater base assembly. The data plates contain important warranty information.

1. Remove logs and heater base assembly from carton. **Note:** Do not pick up heater base assembly by burners. This could damage heater. Always handle base assembly by grate.
2. Remove all protective packaging applied to logs and heater for shipment.
3. Check all items for any shipping damage. If damaged, promptly inform dealer where you bought heater.

PRODUCT IDENTIFICATION

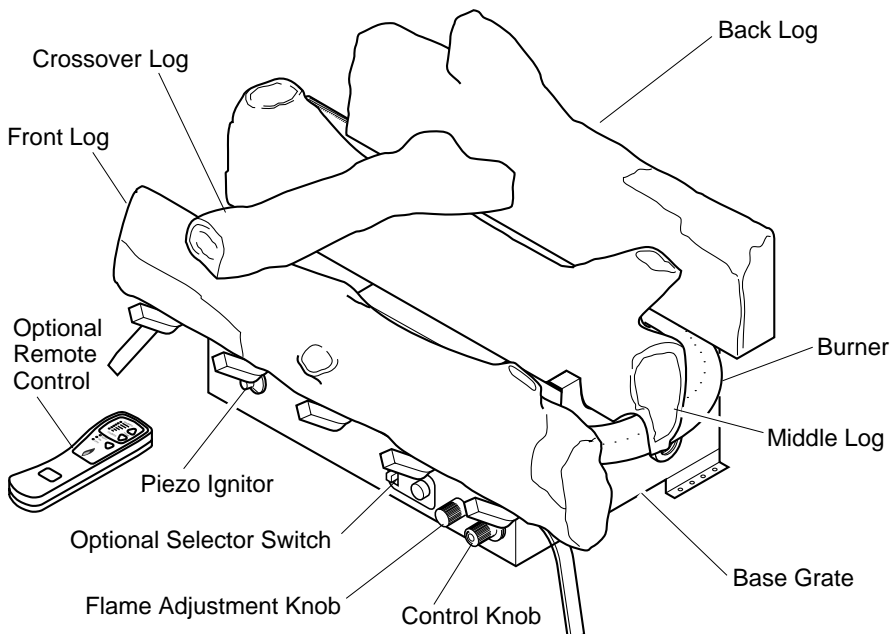

Figure 1 - Yellow Flame Vent-Free Gas Log Heater Shown (Logs May Vary by Model)

PRODUCT FEATURES

OPERATION

This heater is clean burning. It requires no outside venting. There is no heat loss out a vent or up a chimney. Heat is generated by realistic dancing, yellow flames. This heater is designed for vent-free operation with flue damper closed. It has been tested and approved to ANS Z21.11.2 standard for unvented heaters. State and local codes in some areas prohibit the use of vent-free heaters. This heater may also be operated as a vented decorative (ANS Z21.60) product by opening flue damper (non-thermostat models only).

SAFETY PILOT

This heater has a pilot with an Oxygen Depletion Sensing (ODS) safety shutoff system. The ODS/pilot is a required feature for vent-free room heaters. The ODS/pilot shuts off the heater if there is not enough fresh air.

PIEZO IGNITION SYSTEM

This heater has a piezo ignitor. This system requires no matches, batteries, or other sources to light heater.

UNVENTED NATURAL GAS LOG HEATER

REMOTE CONTROL ACCESSORIES

There are two optional remote controls that can be purchased separately for this log heater:

- hand-held ON/OFF remote
- hand-held thermostat remote

See *Accessories*, page 27.

The hand-held thermostat may not be used where vented decorative listing is required.

AIR FOR COMBUSTION AND VENTILATION

⚠ WARNING: This heater shall not be installed in a confined space or unusually tight construction unless provisions are provided for adequate combustion and ventilation air. Read the following instructions to insure proper fresh air for this and other fuel-burning appliances in your home.

Today's homes are built more energy efficient than ever. New materials, increased insulation, and new construction methods help reduce heat loss in homes. Home owners weather strip and caulk around windows and doors to keep the cold air out and the warm air in. During heating months, home owners want their homes as airtight as possible.

While it is good to make your home energy efficient, your home needs to breathe. Fresh air must enter your home. All fuel-burning appliances need fresh air for proper combustion and ventilation.

Exhaust fans, fireplaces, clothes dryers, and fuel burning appliances draw air from the house to operate. You must provide adequate fresh air for these appliances. This will insure proper venting of vented fuel-burning appliances.

PROVIDING ADEQUATE VENTILATION

The following are excerpts from *National Fuel Gas Code, NFPA 54/ANS Z223.1, Section 5.3, Air for Combustion and Ventilation*.

All spaces in homes fall into one of the three following ventilation classifications:

1. Unusually Tight Construction
2. Unconfined Space
3. Confined Space

The information on pages 4 through 6 will help you classify your space and provide adequate ventilation.

Unusually Tight Construction

The air that leaks around doors and windows may provide enough fresh air for combustion and ventilation. However, in buildings of unusually tight construction, you must provide additional fresh air.

Unusually tight construction is defined as construction where:

- a. walls and ceilings exposed to the outside atmosphere have a continuous water vapor retarder with a rating of one perm (6×10^{-11} kg per pa-sec- m^2) or less with openings gasketed or sealed **and**
- b. weather stripping has been added on openable windows and doors **and**
- c. caulking or sealants are applied to areas such as joints around window and door frames, between sole plates and floors, between wall-ceiling joints, between wall panels, at penetrations for plumbing, electrical, and gas lines, and at other openings.

If your home meets all of the three criteria above, you must provide additional fresh air. See *Ventilation Air From Outdoors*, page 6.

If your home does not meet all of the three criteria above, proceed to *Determining Fresh-Air Flow For Heater Location*, page 5.

Confined Space and Unconfined Space

The *National Fuel Gas Code, ANS Z2123.1* defines a confined space as a space whose volume is less than 50 cubic feet per 1,000 Btu per hour (4.8 m³ per kw) of the aggregate input rating of all appliances installed in that space and an unconfined space as a space whose volume is not less than 50 cubic feet per 1,000 Btu per hour (4.8 m³ per kw) of the aggregate input rating of all appliances installed in that space. Rooms communicating directly with the space in which the appliances are installed*, through openings not furnished with doors, are considered a part of the unconfined space.

This heater shall not be installed in a confined space or unusually tight construction unless provisions are provided for adequate combustion and ventilation air.

* Adjoining rooms are communicating only if there are doorless passageways or ventilation grills between them.

AIR FOR COMBUSTION AND VENTILATION

Continued

DETERMINING FRESH-AIR FLOW FOR HEATER LOCATION

Determining if You Have a Confined or Unconfined Space

Use this work sheet to determine if you have a confined or unconfined space.

Space: Includes the room in which you will install heater plus any adjoining rooms with doorless passageways or ventilation grills between the rooms.

- 1. Determine the volume of the space (length x width x height).

Length x Width x Height = _____ cu. ft. (volume of space)

Example: Space size 20 ft. (length) x 16 ft. (width) x 8 ft. (ceiling height) = 2560 cu. ft. (volume of space)

If additional ventilation to adjoining room is supplied with grills or openings, add the volume of these rooms to the total volume of the space.

- 2. Divide the space volume by 50 cubic feet to determine the maximum Btu/Hr the space can support.

_____ (volume of space) ÷ 50 cu. ft. = (Maximum Btu/Hr the space can support)

Example: 2560 cu. ft. (volume of space) ÷ 50 cu. ft. = 51.2 or 51,200 (maximum Btu/Hr the space can support)

- 3. Add the Btu/Hr of all fuel burning appliances in the space.

Vent-free heater	_____ Btu/Hr	
Gas water heater*	_____ Btu/Hr	
Gas furnace	_____ Btu/Hr	
Vented gas heater	_____ Btu/Hr	
Gas fireplace logs	_____ Btu/Hr	
Other gas appliances* +	_____ Btu/Hr	
Total	= _____ Btu/Hr	

Example:

Gas water heater	40,000	Btu/Hr
Vent-free heater	+ 39,000	Btu/Hr
Total	= 79,000	Btu/Hr

* Do not include direct-vent gas appliances. Direct-vent draws combustion air from the outdoors and vents to the outdoors.

- 4. Compare the maximum Btu/Hr the space can support with the actual amount of Btu/Hr used.

_____ Btu/Hr (maximum the space can support)
_____ Btu/Hr (actual amount of Btu/Hr used)

Example: 51,200 Btu/Hr (maximum the space can support)
79,000 Btu/Hr (actual amount of Btu/Hr used)

The space in the above example is a confined space because the actual Btu/Hr used is more than the maximum Btu/Hr the space can support. You must provide additional fresh air. Your options are as follows:

- A. Rework worksheet, adding the space of an adjoining room. If the extra space provides an unconfined space, remove door to adjoining room or add ventilation grills between rooms. See *Ventilation Air From Inside Building*, page 6.
- B. Vent room directly to the outdoors. See *Ventilation Air From Outdoors*, page 6.
- C. Install a lower Btu/Hr heater, if lower Btu/Hr size makes room unconfined.

If the actual Btu/Hr used is less than the maximum Btu/Hr the space can support, the space is an unconfined space. You will need no additional fresh air ventilation.

⚠ WARNING: If the area in which the heater may be operated is smaller than that defined as an unconfined space or if the building is of unusually tight construction, provide adequate combustion and ventilation air by one of the methods described in the *National Fuel Gas Code, ANS Z223.1, Section 5.3* or applicable local codes.

Continued

UNVENTED NATURAL GAS LOG HEATER

AIR FOR COMBUSTION AND VENTILATION

Continued

VENTILATION AIR

Ventilation Air From Inside Building

This fresh air would come from an adjoining unconfined space. When ventilating to an adjoining unconfined space, you must provide two permanent openings: one within 12" of the ceiling and one within 12" of the floor on the wall connecting the two spaces (see options 1 and 2, Figure 2). You can also remove door into adjoining room (see option 3, Figure 2). Follow the *National Fuel Gas Code, NFPA 54/ANS Z223.1, Section 5.3, Air for Combustion and Ventilation* for required size of ventilation grills or ducts.

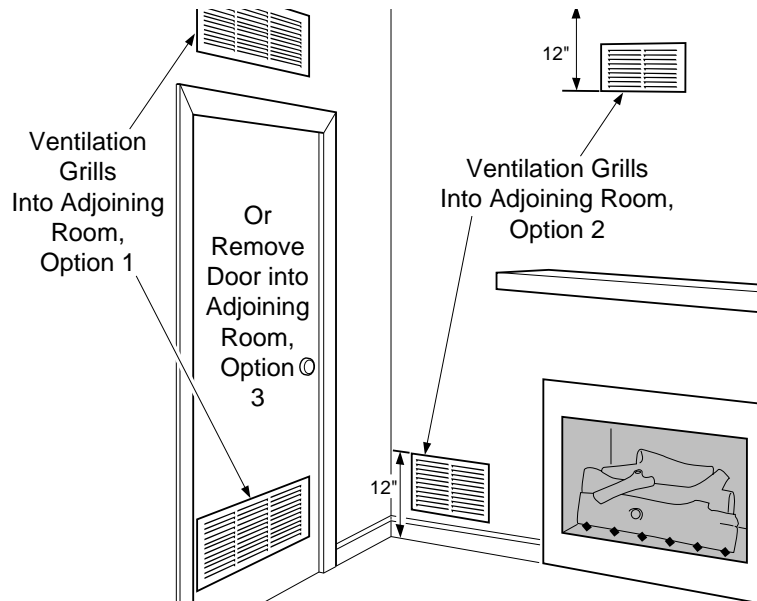

Figure 2 - Ventilation Air from Inside Building

⚠ WARNING: Rework worksheet, adding the space of the adjoining unconfined space. The combined spaces must have enough fresh air to supply all appliances in both spaces.

Ventilation Air From Outdoors

Provide extra fresh air by using ventilation grills or ducts. You must provide two permanent openings: one within 12" of the ceiling and one within 12" of the floor. Connect these items directly to the outdoors or spaces open to the outdoors. These spaces include attics and crawl spaces. Follow the *National Fuel Gas Code, NFPA 54/ANS Z223.1, Section 5.3, Air for Combustion and Ventilation* for required size of ventilation grills or ducts.

IMPORTANT: Do not provide openings for inlet or outlet air into attic if attic has a thermostat-controlled power vent. Heated air entering the attic will activate the power vent.

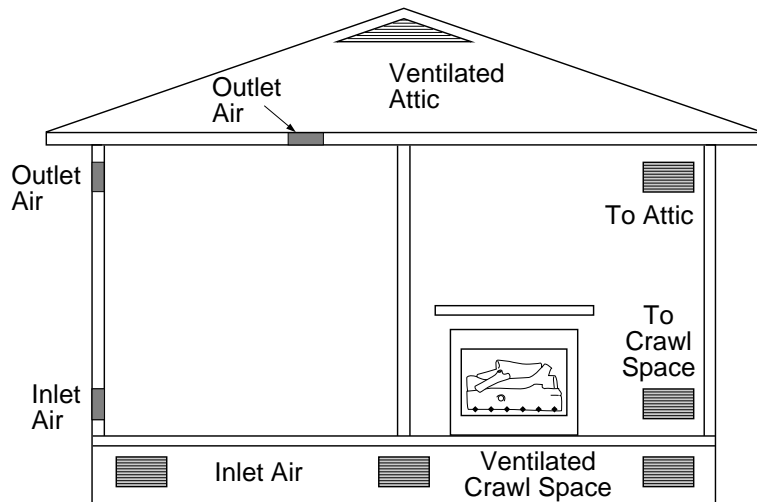

Figure 3 - Ventilation Air from Outdoors

INSTALLATION

NOTICE: This heater is intended for use as supplemental heat. Use this heater along with your primary heating system. Do not install this heater as your primary heat source. If you have a central heating system, you may run system's circulating blower while using heater. This will help circulate the heat throughout the house. In the event of a power outage, you can use this heater as your primary heat source.

NOTICE: State or local codes may only allow operation of this appliance in a vented configuration. Check your state or local codes.

WARNING: A qualified service person must install heater. Follow all local codes.

WARNING: Make sure the selector switch is in the OFF position before installing heater.

WARNING: Before installing in a solid fuel burning fireplace, the chimney flue and firebox must be cleaned of soot, creosote, ashes, and loose paint by a qualified chimney cleaner. Creosote will ignite if highly heated. A dirty chimney flue may create and distribute soot within the house. Inspect chimney flue for damage. If damaged, operate heater with flue damper closed.

WARNING: Seal any fresh air vents or ash clean-out doors located on floor or wall of fireplace. If not, drafting may cause pilot outage or sooting. Use a heat-resistant sealant. Do not seal chimney flue damper.

WARNING: Never install the heater

- in a bedroom or bathroom unless installed as a vented appliance, see page 10.
- in a recreational vehicle
- where curtains, furniture, clothing, or other flammable objects are less than 42 inches from the front, top, or sides of the heater
- in high traffic areas
- in windy or drafty areas

CAUTION: This heater creates warm air currents. These currents move heat to wall surfaces next to heater. Installing heater next to vinyl or cloth wall coverings or operating heater where impurities (such as tobacco smoke, aromatic candles, cleaning fluids, oil or kerosene lamps, etc.) in the air exist, may discolor walls.

IMPORTANT: Vent-free heaters add moisture to the air. Although this is beneficial, installing heater in rooms without enough ventilation air may cause mildew to form from too much moisture. See *Air for Combustion and Ventilation*, pages 4 through 6.

CHECK GAS TYPE

Use only natural gas. If your gas supply is not natural gas, do not install heater. Call dealer where you bought heater for property heater.

INSTALLATION AND CLEARANCES (Vent-Free Operation Only)

WARNING: Maintain the minimum clearances. If you can, provide greater clearances from floor, ceiling, and adjoining wall.

MINIMUM FIREPLACE CLEARANCE TO COMBUSTIBLE MATERIALS

Log Size	Side Wall	Ceiling
24"	16"	42"

LOG SIZING REQUIREMENTS

Log Size	Minimum Firebox Size			
	Height	Depth	Front Width	Rear Width*
24"	17"	13"	28"	21"
30"	17"	13"	34"	24"

*Measured at 13" depth

Carefully follow the instructions below. This will ensure safe installation into a masonry, UL127-listed manufactured fireplace, or listed vent-free firebox.

Minimum Clearances for Side Combustible Material, Side Wall, and Ceiling

A. Clearances from the side of the fireplace cabinet to any combustible material and wall should follow diagram in Figure 4.

Example: The face of a mantel, bookshelf, etc. is made of combustible material and protrudes 3 1/2" from the wall. This combustible material must be 4" from the side of the fireplace opening (see Figure 4).

Note: When installing your gas logs into a manufactured firebox, follow firebox manufacturer's instructions for minimum clearances to combustible materials.

B. Clearances from the top of the fireplace opening to the ceiling should not be less than 42 inches.

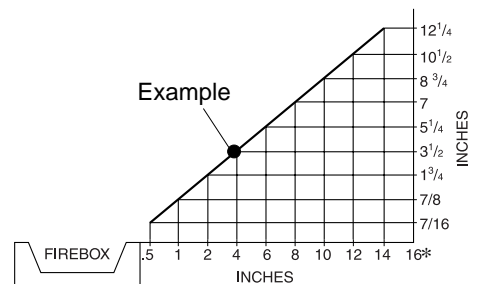

*Minimum 16 inches from Side Wall

Figure 4 - Minimum Clearance for Side Combustible Material, Side Wall, and Ceiling.

UNVENTED NATURAL GAS LOG HEATER

INSTALLATION

Continued

NOTICE: Manual control heaters may be used as a vented product. If so, you must always run heater with chimney flue damper open. If running heater with damper open, noncombustible material above fireplace opening is not needed. Go to *Installing Damper Clamp Accessory for Vented Operation*, page 10.

Minimum Noncombustible Material Clearances

If Not Using Mantel

Note: If using a mantel, go to *If Using Mantel*. If not using a mantel, follow the information below.

You must have noncombustible material(s) above the fireplace opening. Noncombustible materials (such as slate, marble, tile, etc.) must be at least 1/2 inch thick. With sheet metal, you must have noncombustible material behind it. Noncombustible material must extend at least 8" up (for all models). If noncombustible material is less than 12", you must install the fireplace hood accessory (24" and 30" models only). See Figure 5 for minimum clearances.

IMPORTANT: If you cannot meet these minimum clearances, you must operate heater with chimney flue damper open. Go to *Installing Damper Clamp Accessory for Vented Operation*, page 10.

If Using Mantel

You must have noncombustible material(s) above the fireplace opening. Noncombustible materials (such as slate, marble, tile, etc.) must be at least 1/2 inch thick. With sheet metal, you must have noncombustible material behind it. Noncombustible material must extend at least 8 inches up (for all models). If noncombustible material is less than 12", you must install the fireplace hood accessory (24" and 30" models only). Even

if noncombustible material is more than 12", you may need the hood accessory to deflect heat away from your mantel shelf. See Figure 5 and Figures 6 and 7 on page 9 for minimum clearances.

IMPORTANT: If you cannot meet these minimum clearances, you must operate heater with chimney flue damper open. Go to *Installing Damper Clamp Accessory for Vented Operation*, page 10.

Noncombustible Material Distance (A)	Requirements for Safe Installation
12" or more	Noncombustible material okay.
Between 8" and 12"	Install fireplace hood accessory (GA6050, GA6052, or GA6053, see <i>Accessories</i> , page 27).
Less than 8"	Noncombustible material must be extended to at least 8". See <i>Between 8" and 12"</i> , above. If you cannot extend material, you must operate heater with flue damper open.

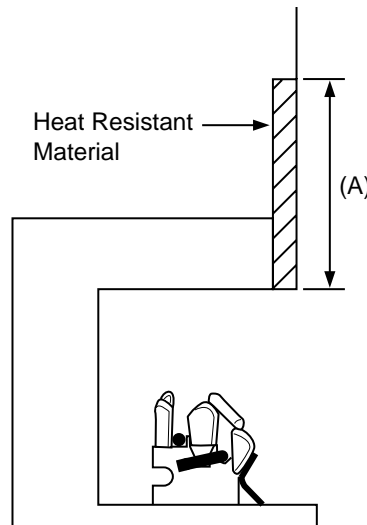

Figure 5 - Heat Resistant Material (Slate, Marble, Tile, etc.) Above Fireplace

INSTALLATION

Continued

MANTEL CLEARANCES

In addition to meeting noncombustible material clearances, you must also meet required clearances between fireplace opening and mantel shelf. If you do not meet the clearances listed below, you will need a hood.

Determining Minimum Mantel Clearances

If you meet minimum clearance between mantel shelf and top of fireplace opening, a hood is not required (see Figure 6).

Determining Minimum Mantel Clearances When Using a Hood

If minimum clearances in Figure 6 are not met, you must have a hood. When using a hood there are still certain minimum mantel clearances required. Follow minimum clearances shown in Figure 7 when using hood.

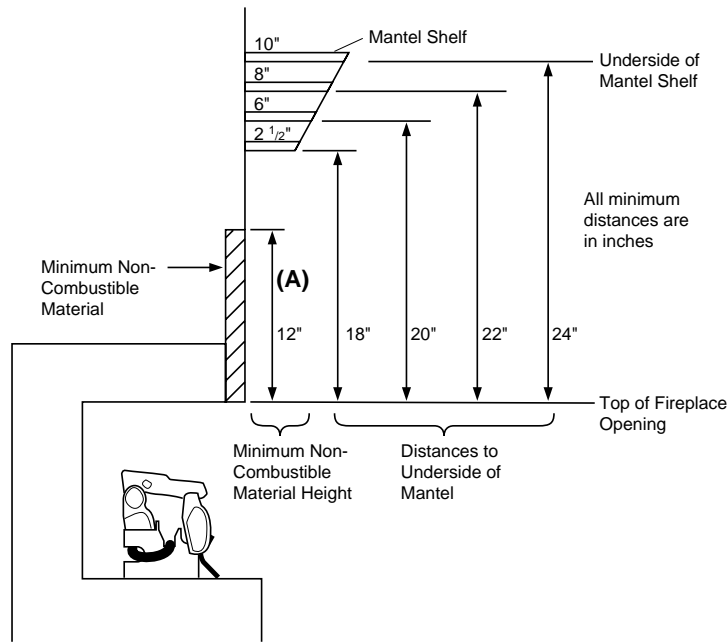

Figure 6 - Minimum Mantel Clearances Without Using Hood

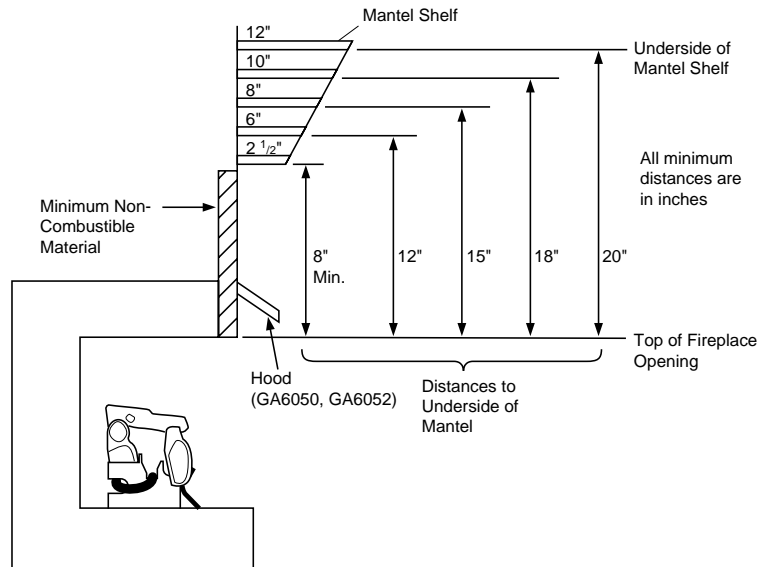

Figure 7 - Minimum Mantel Clearances When Using Hood

NOTICE: Surface temperatures of adjacent walls and mantels become hot during operation. Walls and mantels above the firebox may become hot to the touch. If installed properly, these temperatures meet the requirements of the national product standard. Follow all minimum clearances shown in this manual.

NOTICE: If your installation does not meet the minimum clearances shown, you must do one of the following:

- operate the logs only with the flue damper open
- raise the mantel to an acceptable height
- remove the mantel

FLOOR CLEARANCES

- A. If installing appliance on the floor level, you must maintain the minimum distance of 14" to combustibles (see Figure 8).
- B. If combustible materials are less than 14" to the fireplace, you must install appliance at least 5" above the combustible flooring (see Figure 9).

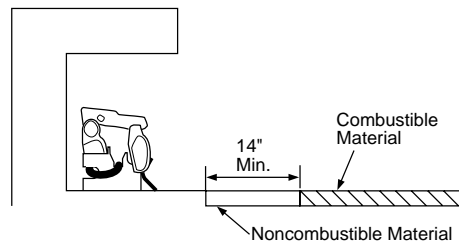

Figure 8 - Minimum Fireplace Clearances If Installed at Floor Level

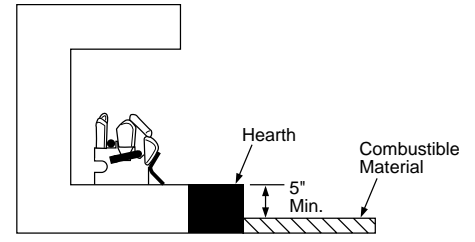

Figure 9 - Minimum Fireplace Clearances Above Combustible Flooring

Continued

UNVENTED NATURAL GAS LOG HEATER

INSTALLATION

Continued

INSTALLING DAMPER CLAMP ACCESSORY FOR VENTED OPERATION

Note: When used as a vented heater, appliance must be installed only in a solid-fuel burning fireplace with a working flue and constructed of noncombustible material.

If your heater is a manually-controlled model, you may use this heater as a vented product. There are three reasons for operating your heater in the vented mode.

1. The fireplace does not meet the clearance to combustibles requirements for vent-free operation.
2. State or local codes do not permit vent-free operation.
3. You prefer vented operation.

If reasons number 1 or 2 above apply to you, you must permanently open chimney flue damper. You must install the damper clamp accessory (to order, see *Accessories*, page 27). This will insure vented operation (see Figure 10). The damper clamp will keep damper open. Installation instructions are included with clamp accessory.

See chart below for minimum permanent flue opening you must provide. Attach damper clamp so the minimum permanent flue opening will be maintained at all times.

Chimney Height (ft.)	Minimum Permanent Flue Opening (sq. ins.)
6' to 15'	39 sq. inches
15' to 30'	29 sq. inches

Area of Various Standard Round Flues	
Diameter (ins.)	Area (sq. ins.)
5"	20 sq. inches
6"	29 sq. inches
7"	39 sq. inches
8"	51 sq. inches

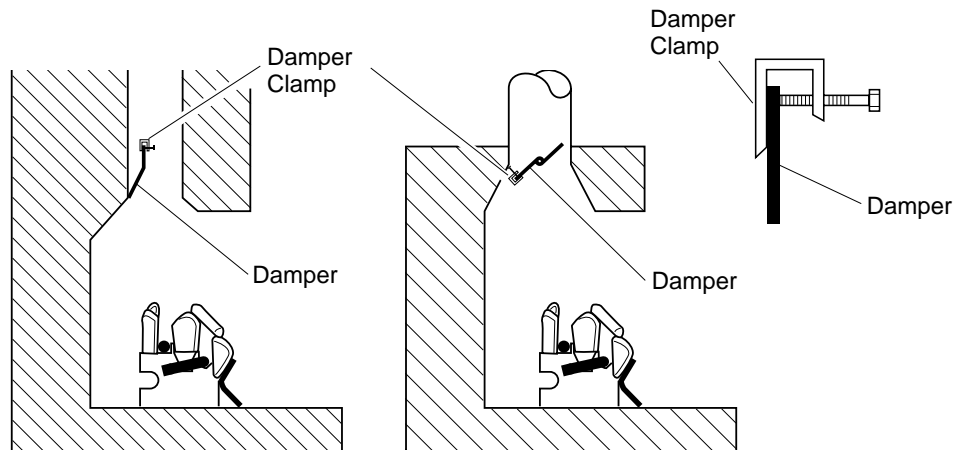

Masonry Fireplace
Manufactured Fireplace
Figure 10 - Attaching Damper Clamp

INSTALLING HEATER BASE ASSEMBLY

CAUTION: Do not remove the metal data plates attached to the heater base assembly. The data plates contain important warranty information.

WARNING: You must secure this heater to fireplace floor. If not, heater will move when you adjust controls. Moving heater may cause a gas leak.

WARNING: If installing in a sunken fireplace, special care is needed. You must raise the fireplace floor to allow access to heater control panel. This will insure adequate air flow and guard against sooting. Raise fireplace floor with noncombustible material. Make sure material is secure.

CAUTION: Do not pick up heater base assembly by the burner. This could damage heater. Only handle base assembly by grates.

IMPORTANT: Make sure the heater burners are level. If heater is not level, heater will not work properly.

Installation Items Needed

- hardware package (provided with heater)
- approved flexible gas hose (not provided) (if allowed by local codes)
- sealant resistant to propane/LP gas, not provided
- electric drill with 3/16" masonry drill bit

Note: Install optional remote receiver and hand-held remote kit (see *Accessories*, page 27) before installing gas log heater. See installation instructions included with the kit.

1. Apply pipe joint sealant lightly to male threads of the fitting to be threaded into gas regulator. Connect approved flexible gas hose to gas regulator of heater (see Figure 11, page 11).
2. Locate masonry screws in hardware package.
3. Position heater base assembly in fireplace.
4. Mark screw locations through holes in mounting flanges (see Figure 12, page 11). If installing in a brick-bottom fireplace, mark screw locations in mortar joint of bricks.
5. Remove heater base from fireplace.
6. Drill holes at marked locations using 3/16" masonry drill bit.

INSTALLATION

Continued

- Attach base assembly to fireplace floor using two masonry screws (in hardware package) (see Figure 12).
- Connect to gas supply. See *Connecting To Gas Supply*.

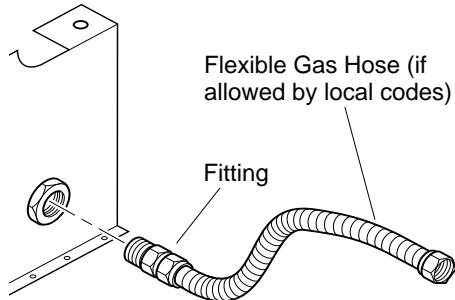

Figure 11 - Attaching Flexible Gas Hose to Heater

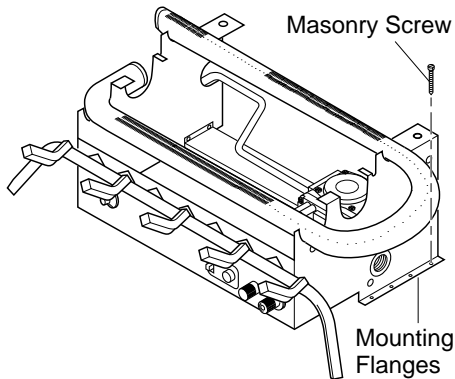

Figure 12 - Attaching Base Assembly to Fireplace Floor

CONNECTING TO GAS SUPPLY

WARNING: This appliance requires a 1/2" NPT (National Pipe Thread) inlet connection to the pressure regulator.

WARNING: A qualified service person must connect heater to gas supply. Follow all local codes.

Installation Items Needed

Before installing heater, make sure you have the items listed below.

- piping (check local codes)
- sealant (resistant to propane/LP gas)
- equipment shutoff valve *
- test gauge connection *
- sediment trap
- tee joint
- pipe wrench

* An CSA design-certified equipment shutoff valve with 1/8" NPT tap is an acceptable alternative to test gauge connection. Purchase the optional CSA design-certified equipment shutoff valve from your dealer. See *Accessories*, page 27.

WARNING: Never connect heater to private (non-utility) gas wells. This gas is commonly known as wellhead gas.

CAUTION: Use only new, black iron or steel pipe. Internally-tinned copper tubing may be used in certain areas. Check your local codes. Use pipe of 1/2" diameter or greater to allow proper gas volume to heater. If pipe is too small, undue loss of pressure will occur.

Installation must include an equipment shutoff valve, union, and plugged 1/8" NPT tap. Locate NPT tap within reach for test gauge hook up. NPT tap must be upstream from heater (see Figure 13).

IMPORTANT: Install equipment shutoff valve in an accessible location. The equipment shutoff valve is for turning on or shutting off the gas to the appliance.

Apply pipe joint sealant lightly to male threads. This will prevent excess sealant from going into pipe. Excess sealant in pipe could result in clogged heater valves.

CAUTION: Use pipe joint sealant that is resistant to liquid petroleum (LP) gas.

We recommend that you install a sediment trap in supply line as shown in Figure 12. Locate sediment trap where it is within reach for cleaning. Install in piping system between fuel supply and heater. Locate sediment trap where trapped matter is not likely to freeze. A sediment trap traps moisture and contaminants. This keeps them from going into heater controls. If sediment trap is not installed or is installed wrong, heater may not run properly.

CAUTION: Avoid damage to regulator. Hold gas regulator with wrench when connecting it to gas piping and/or fittings.

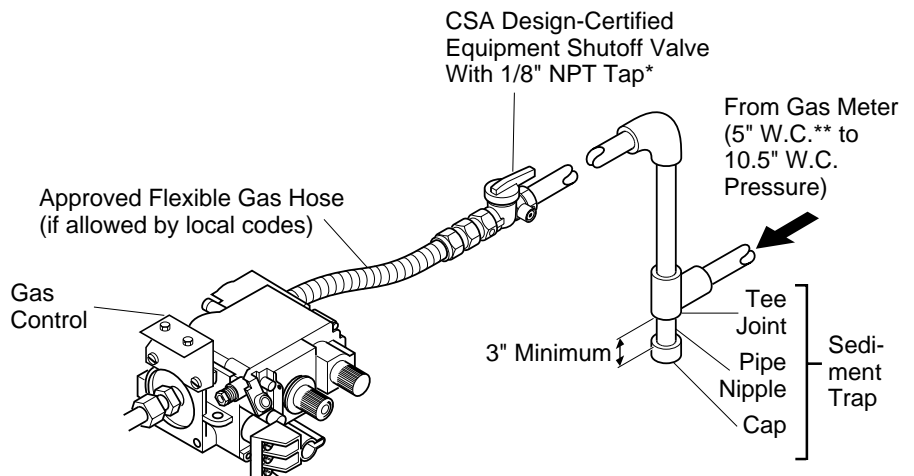

Figure 13 - Gas Connection

* Purchase the optional CSA design-certified equipment shutoff valve from your dealer. See *Accessories*, page 27.

** Minimum inlet pressure for purpose of input adjustment.

Continued

UNVENTED NATURAL GAS LOG HEATER

INSTALLATION

Continued

CHECKING GAS CONNECTIONS

⚠ WARNING: Test all gas piping and connections for leaks after installing or servicing. Correct all leaks at once.

⚠ WARNING: Never use an open flame to check for a leak. Apply a mixture of liquid soap and water to all joints. Bubbles forming show a leak. Correct all leaks at once.

Pressure Testing gas Supply Piping system

Test Pressures In Excess Of 1/2 PSIG (3.5 kPa)

1. Disconnect appliance with its appliance main gas valve (control valve) and equipment shutoff valve from gas supply piping system. Pressures in excess of 1/2 psig will damage heater regulator.
2. Cap off open end of gas pipe where equipment shutoff valve was connected.
3. Pressurize supply piping system by either using compressed air or opening main gas valve located on or near gas meter.
4. Check all joints of gas supply piping system. Apply mixture of liquid soap and water to gas joints. Bubbles forming show a leak.
5. Correct all leaks at once.
6. Reconnect heater and equipment shutoff valve to gas supply. Check reconnected fittings for leaks.

Test Pressures Equal To or Less Than 1/2 PSIG (3.5 kPa)

1. Close equipment shutoff valve (see Figure 14).
2. Pressurize supply piping system by either using compressed air or opening main gas valve located on or near gas meter.
3. Check all joints from gas meter to equipment shutoff valve (see Figure 15). Apply mixture of liquid soap and water to gas joints. Bubbles forming show a leak.
4. Correct all leaks at once.

Pressure Testing Heater Gas Connections

1. Open equipment shutoff valve (see Figure 14).
2. Open main gas valve located on or near gas meter.
3. Make sure control knob of heater is in the OFF position.
4. Check all joints from equipment shutoff valve to control valve (see Figure 15). Apply mixture of liquid soap and water to gas joints. Bubbles forming show a leak.
5. Correct all leaks at once.
6. Light heater (see *Operating Heater*, pages 15 through 17). Check all other internal joints for leaks.
7. Turn off heater (see *To Turn Off Gas to Appliance*, page 16).

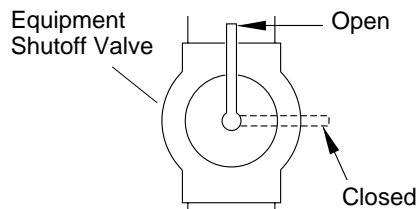

Figure 14 - Equipment Shutoff Valve

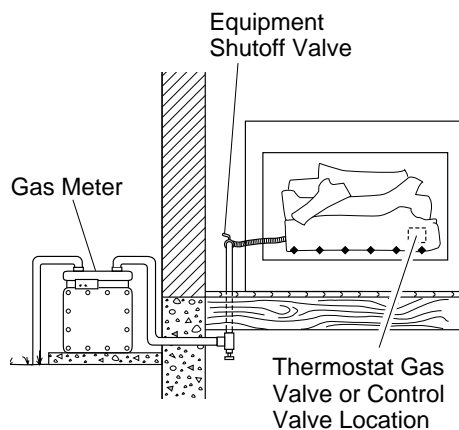

Figure 15 - Checking Gas Joints

INSTALLING REMOTE RECEIVER UNIT

1. Disconnect switch wires from the control valve.
2. Remove phillips head screws and heat shield.
3. Remove switch plate (see Figure 16). Discard after removing.
4. Install remote receiver unit onto gas log heater base using phillips head screws.
5. Connect wires as shown in Figure 18.

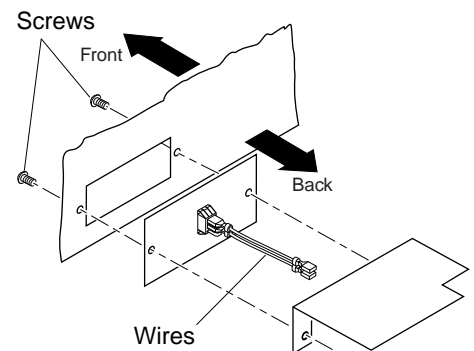

Figure 16 - Switch Plate and Wiring Harness (Switch Plate and Orientation May Vary Depending On Model)

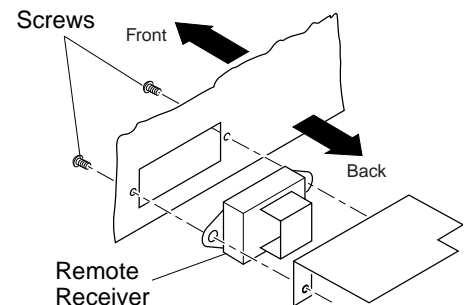

Figure 17 - Installing Remote Receiver

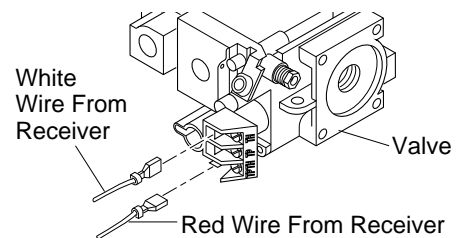

Figure 18 - Connecting Wires

INSTALLATION

Continued

INSTALLING WIRELESS REMOTE CONTROL ACCESSORY

Two 9-volt alkaline batteries (not included) are required to operate this heater with the wireless hand-held remote control set. One battery must be installed in the receiver and one in the hand-held remote control unit. *Note:* Only use alkaline batteries.

Installing 9-Volt Battery in Receiver

1. Locate back of receiver under front burner of heater.
2. Locate the battery clip mounted on the back of the receiver.
3. Slide a 9-volt battery through the clip.
4. Attach the terminal wires to the battery.

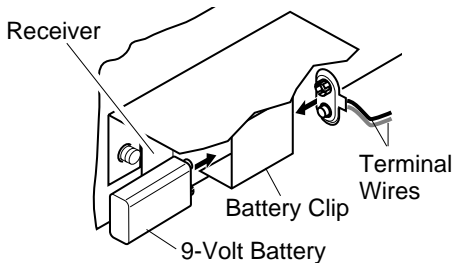

Figure 19 - Installing Receiver on the Back of the Base

Installing 9-Volt Battery (Not Included) in Hand-Held Remote Control Unit

1. Remove battery cover on back of remote control unit.
2. Attach terminal wires to the battery. Place battery into the battery housing.
3. Replace battery cover onto remote control unit.

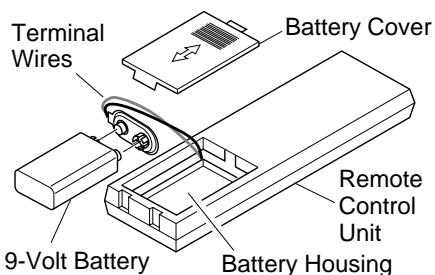

Figure 20 - Installing Battery in Hand-Held Remote Control Unit

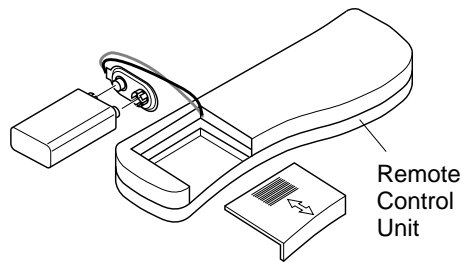

Figure 21 - Installing Battery in Hand-Held Remote Control Unit (CGHRCTA Series)

INSTALLING LOGS (CGD3924NRA)

WARNING: Failure to position the parts in accordance with these diagrams or failure to use only parts specifically approved with this heater may result in property damage or personal injury.

CAUTION: After installation and periodically thereafter, check to ensure that no flame comes in contact with any log. With the heater set to HIGH, check to see if flames contact any log. If so, reposition logs according to the log installation instructions in this manual. Flames contacting logs will create soot.

Each log is marked with a number. These numbers will help you identify the log when installing. It is very important to install these logs exactly as instructed. Do not modify logs. Only use logs supplied with heater.

1. Locate pegs on the bottom of back log (#1). Slide these pegs into the holes in the grate base behind the burner (see Figure 22).
2. Place the base of the middle log (#2) in the U-shaped slots of the grate base in front of the back log. The cutout on the right of the middle log should fit over the burner (see Figure 23). Make sure the front of the middle log is resting on the tabs of the grate base and the cutout area is centered over the burner "U" bend.
3. Locate the recesses on the back of the front log (#3). Fit these recesses between the posts of the grate base (see Figure 24).

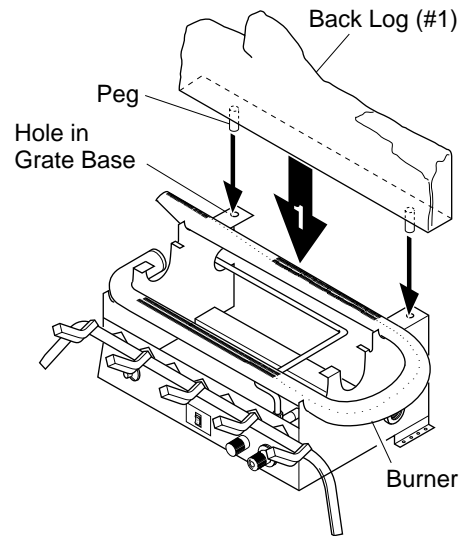

Figure 22 - Installing Back Log (#1)

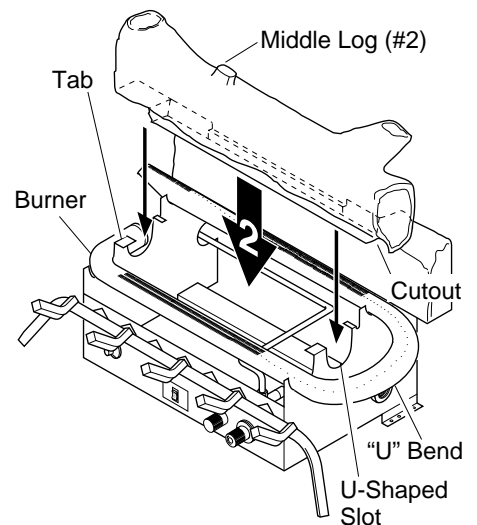

Figure 23 - Installing Middle Log (#2)

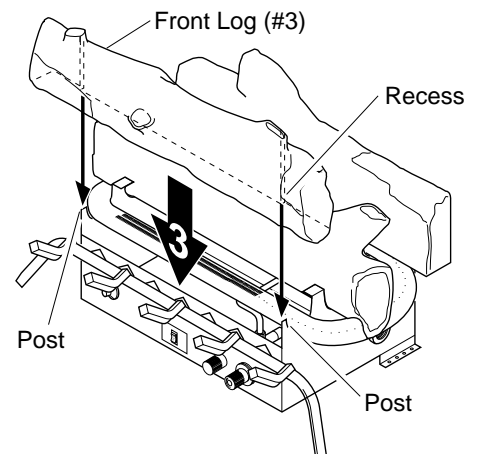

Figure 24 - Installing Front Log (#3)

Continued

UNVENTED NATURAL GAS LOG HEATER

INSTALLATION

Continued

4. Locate the notches in the bottom of the crossover log (#4). Place the crossover log on top of the middle log and front log. Make sure the notches of the crossover log lines up with rectangular knobs on top of the middle and front logs (see Figure 25).
5. Add lava rock around base of heater. Do not place any lava rock on logs or burner.

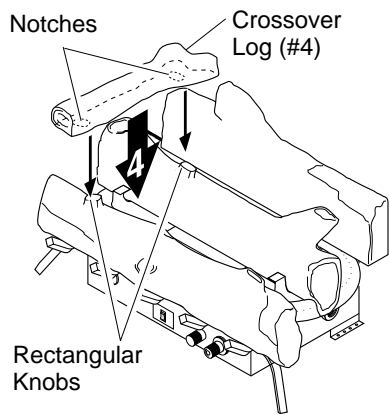

Figure 25 - Installing Crossover Log (#4)

INSTALLING LOGS (CCL3924NR AND CCL3930NR)

⚠ WARNING: Failure to position the parts in accordance with these diagrams or failure to use only parts specifically approved with this heater may result in property damage or personal injury.

⚠ CAUTION: After installation and periodically thereafter, check to ensure that no flame comes in contact with any log. With the heater set to HIGH, check to see if flames contact any log. If so, reposition logs according to the log installation instructions in this manual. Flames contacting logs will create soot.

Each log is marked with a number. These numbers will help you identify the log when installing. It is very important to install these logs exactly as instructed. Do not modify logs. Only use logs supplied with heater.

1. Place the front log (#1) on the grate fingers. Make sure the front log rests firmly between the grate fingers and the grate base (see Figure 26).
2. Place the base of the middle log (#2) in the U-shaped slots of the grate base. The cutout on the right of the middle log should fit over the burner (see Figure 27). Make sure the front of the middle log is resting on the tabs of the grate base.
3. Locate pegs on the bottom of back log (#3). Slide these pegs into the holes in the grate base behind the burner (see Figure 28).
4. Locate pegs on the bottom of crossover log (#4). Slide these pegs into the holes located in middle log (#2) and back log (#3). See Figure 29 for placement.
5. Locate pegs on the bottom of crossover log (#5). Slide these pegs into the holes located in crossover log (#4) and front log (#1). See Figure 30.
6. Locate pegs on the bottom of crossover log (#6). Slide these pegs into the holes located in middle log (#2) and front log (#1). See Figure 31, page 15.

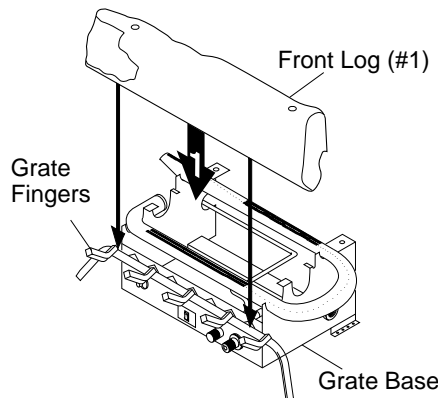

Figure 26 - Installing Front Log (#1)
(CCL3930NR Shown)

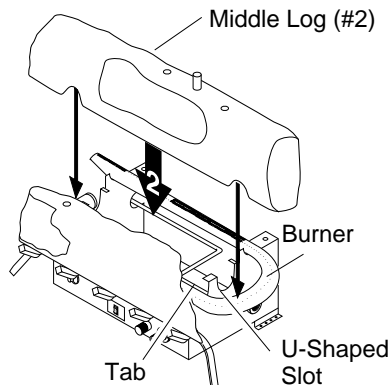

Figure 27 - Installing Middle Log (#2)
(CCL3930NR Shown)

7. For CCL3930NR only, locate holes on the bottom of crossover log (#7). Slide onto the pegs located in crossover log (#6) and middle log (#2). See Figure 32, page 15.
8. Add lava rock around base of heater. Do not place any lava rock on logs or burner.

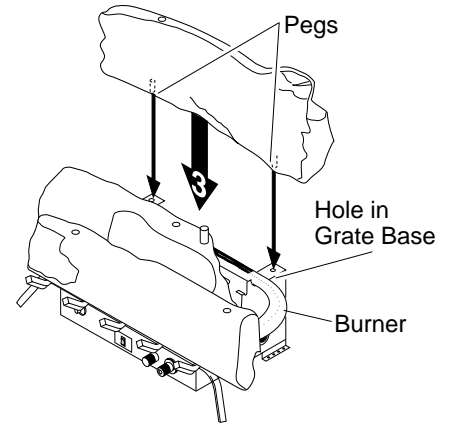

Figure 28 - Installing Rear Log (#3)
(CCL3930NR Shown)

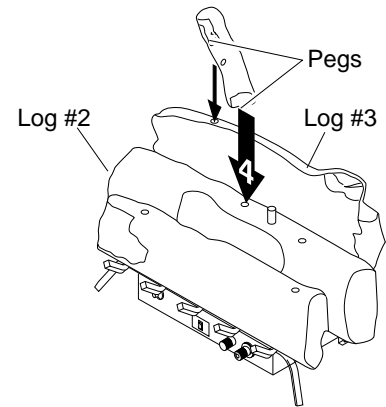

Figure 29 - Installing Crossover Log (#4)
(CCL3930NR Shown)

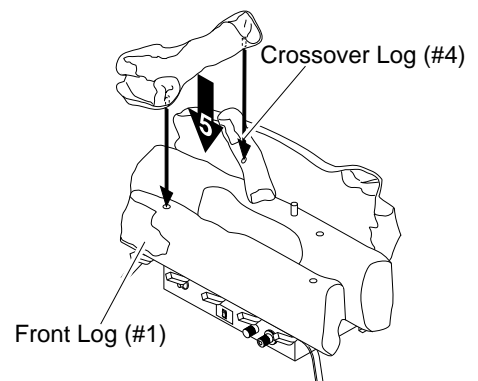

Figure 30 - Installing Crossover Log (#5)
(CCL3930NR Shown)

INSTALLATION

Continued

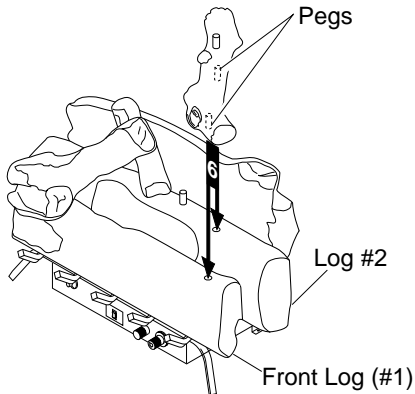

Figure 31 - Installing Crossover Log (#6) (CCL3930NR Shown)

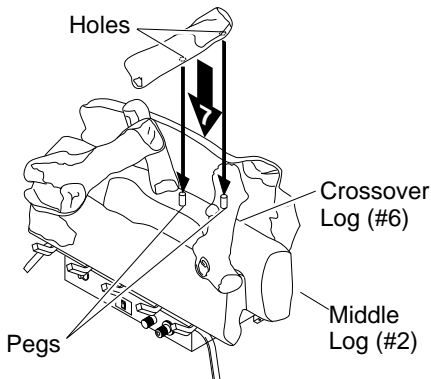

Figure 32 - Installing Crossover Log (#7) to Model CCL3930NR Only

OPERATING HEATER

**FOR YOUR SAFETY
READ BEFORE
LIGHTING**

WARNING: If you do not follow these instructions exactly, a fire or explosion may result causing property damage, personal injury or loss of life.

- This appliance has a pilot which must be lighted by hand. When lighting the pilot, follow these instructions exactly.
- BEFORE LIGHTING** smell all around the appliance area for gas. Be sure to smell next to the floor because some gas is heavier than air and will settle on the floor.

WHAT TO DO IF YOU SMELL GAS

- Do not try to light any appliance.
 - Do not touch any electric switch; do not use any phone in your building.
 - Immediately call your gas supplier from a neighbor's phone. Follow the gas supplier's instructions.
 - If you cannot reach your gas supplier, call the fire department.
- Use only your hand to push in or turn the gas control knob. Never use tools. If the knob will not push in or turn by hand, don't try to repair it, call a qualified service technician or gas supplier. Force or attempted repair may result in a fire or explosion.
 - Do not use this appliance if any part has been under water. Immediately call a qualified service technician to inspect the appliance and to replace any part of the control system and any gas control which has been under water.

LIGHTING INSTRUCTIONS

WARNING:

- If fireplace has glass doors, never operate this heater with glass doors closed. If you operate heater with doors closed, heat buildup inside fireplace will cause glass to burst. Also if fireplace opening has vents at the bottom, you must open the vents before operating heater.
- You must operate this heater with a fireplace screen in place. Make sure fireplace screen is closed before running heater.

NOTICE: During initial operation of new heater, burning logs will give off a paper-burning smell. Orange flame will also be present. Open damper or window to vent smell. This will only last a few hours.

Note: Home owners generally prefer to operate their heater with the chimney damper closed. This will put all the heat into the room. However, there may be times you will desire the full flames of the Hi heat setting but will find the heat output excessive. You can open the chimney damper (if you have one) fully or partially to release some of the heat.

WARNING: Damper handle will be hot if heater has been running.

- STOP!** Read the safety information in columns 1 and 2.
- Make sure equipment shutoff valve is fully open.
- Set selector switch in the OFF position.

WARNING: Burners will come on automatically within one minute when the remote selector switch is in the ON position after the pilot is lit.

- Press in and turn control knob clockwise to the OFF position.
- Wait five (5) minutes to clear out any gas. Then smell for gas, including near the floor. If you smell gas, **STOP!** Follow "B" in the safety information, columns 1 and 2. If you don't smell gas, go to the next step.

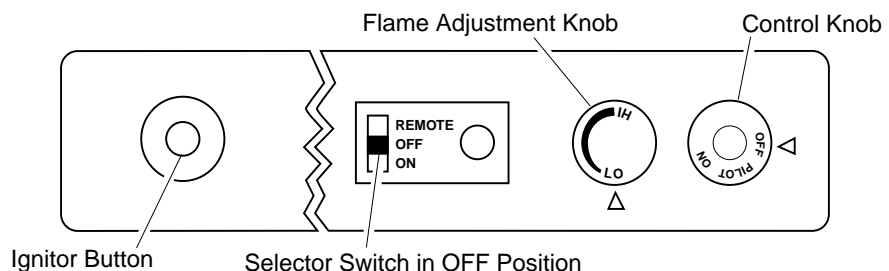



Figure 33 - Control Knob and Ignitor Button Location

Continued

UNVENTED NATURAL GAS LOG HEATER

OPERATING HEATER

Continued

- Press in and turn control knob counterclockwise  to the PILOT position. Press in control knob for five (5) seconds (see Figure 33, page 15).

Note: You may be running this heater for the first time after hooking up to gas supply. If so, the control knob may need to be pressed in for 30 seconds or more. This will allow air to bleed from the gas system.

- With control knob pressed in, press and release ignitor button. This will light pilot. The pilot is attached to the front burner. If needed, keep pressing ignitor button until pilot lights.

Note: If pilot does not stay lit, contact a qualified service person or gas supplier for repairs. Until repairs are made, light pilot with match. To light pilot with match, see *Manual Lighting Procedure*.

- Keep control knob pressed in for 30 seconds after lighting pilot. After 30 seconds, release control knob.
 - If control knob does not pop out when released, contact a qualified service person or gas supplier for repairs.

Note: If pilot goes out, repeat steps 4 through 8, pages 15 and 16.

- Slightly push in and turn control knob counterclockwise  to the ON position.
- Wait one minute and switch selector switch to the ON position to light burners.
- Set flame adjustment knob to any level between HI and LO.

CAUTION: Do not try to adjust heating levels by using the equipment shutoff valve.

WARNING: Make sure the selector switch is in the OFF position when you are away from home for long periods of time. Heater will come on automatically with selector switch in the ON position.

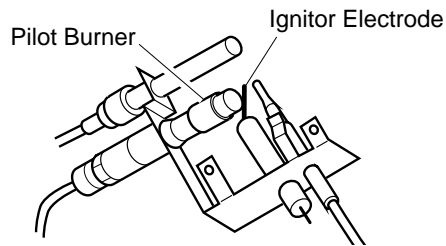



Figure 34 - Pilot

TO TURN OFF GAS TO APPLIANCE

Shutting Off Heater

- Turn control knob clockwise  to the OFF position.
- Set selector switch in the OFF position.
- If Using Optional Hand-Held remote: Set selector switch in the OFF position to keep from draining battery.

Shutting Off Burners Only (pilot stays lit)

You may shut off the burners and keep the pilot lit by doing one of the following:

- Turn control knob clockwise  to the PILOT position.
- Use remote control manual OFF button.
- Set selector switch in the OFF position.

MANUAL LIGHTING PROCEDURE

- Follow steps 1 through 6 under *Lighting Instructions*, pages 15 and 16.
- Depress control knob and light pilot with match.
- Keep control knob pressed in for 30 seconds after lighting pilot. After 30 seconds, release control knob. Now follow steps 9 through 11 under *Lighting Instructions*, column 1.

OPTIONAL REMOTE OPERATION

Note: All remote control accessories must be purchased separately (see *Accessories*, page 27). Follow instructions included with the remote control.

Thermostat Control Operation

(Optional CGHRCTA Only) The thermostat control setting on the remote control unit can be set to any comfort level between WARMER and COOLER. The burner will turn on and off automatically to maintain the comfort level you select. The ideal comfort setting will vary by household depending upon the amount of space to be heated, the output of the central heating system, etc.

NOTICE: You must light the pilot before using the hand-held remote control unit. See *Lighting Instructions* on pages 15 and 16.

- After lighting, let pilot flame burn for about one minute. Turn control knob to ON position. Adjust flame adjustment knob anywhere between HI and LO. Slide the selector switch to the REMOTE position. **Note:** The burners may light if hand-held remote ON button was on when selector switch was last turned off. You can now turn the burners on and off with the hand-held remote control unit.

IMPORTANT: Do not leave the selector switch in the REMOTE position when the pilot is not lit. This will drain the battery.

IMPORTANT: Be sure to press the ON/OFF buttons on the hand-held remote control unit for up to 3 seconds to assure proper operation.

CGHRC Series Operation:

- Press the ON/OFF button to turn the burners on and off. When turning burners off, the pilot will remain lit.

OPERATING HEATER

Continued

CGHRCTA Series Operation:

- 2b. Press the AUTO/ON/OFF button on the hand-held remote control (see Figure 36). The lights to the left of the button will show AUTO, ON, or OFF.
 - In the ON mode, the burners will ignite. The heater is in manual mode when ON is lit.
 - In the AUTO mode, the thermostat in the hand-held remote unit controls the room temperature. To increase the room temperature, press the top arrow of the TEMP button. To lower the room temperature, press the bottom arrow of the TEMP button. At higher settings the heater will run longer.

- IMPORTANT:** This remote control has been specially engineered to take an air temperature sample every 5.5 minutes in the auto mode. It will not respond immediately to the temperature setting being turned up or down.
- IMPORTANT:** The hand-held remote control unit must be near the heater. Do not keep the hand-held remote control unit too close to the heater. The thermostat on the hand-held remote control unit will heat up too quickly and turn the heater off.
3. To turn the burner off, press the AUTO/ON/OFF button until OFF lights. The pilot will remain lit.

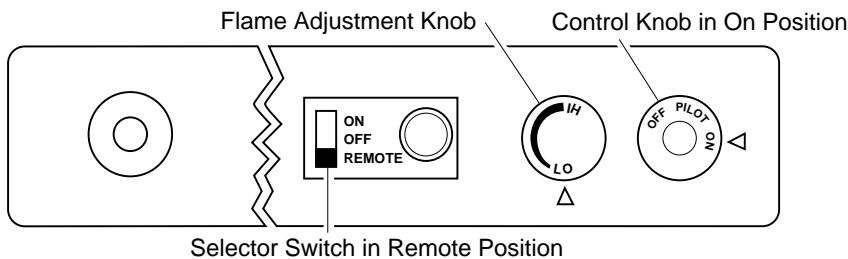

Figure 35 - Setting the Selector Switch, Control Knob, and Flame Adjustment Knob for Remote Operation

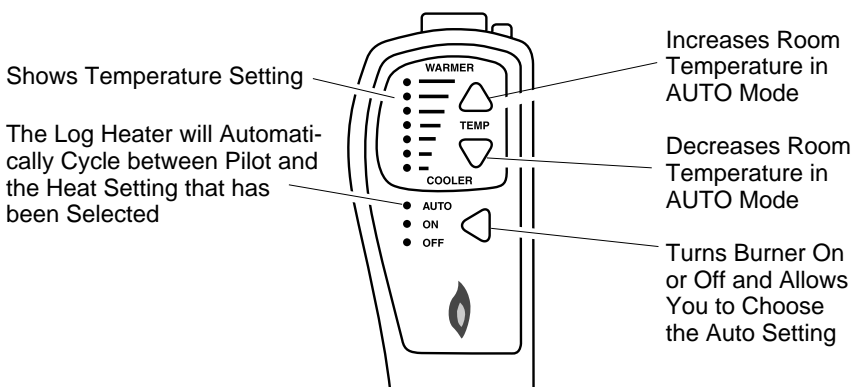

Figure 36 - Thermostat Hand-Held Remote Control Unit Selections (CGHRCTA Series Only)

INSPECTING BURNERS

Check pilot flame pattern and burner flame patterns often.

PILOT FLAME PATTERN

Figure 37 shows a correct pilot flame pattern. Figure 38 shows an incorrect pilot flame pattern. The incorrect pilot flame is not touching the thermocouple. This will cause the thermocouple to cool. When the thermocouple cools, the heater will shut down.

If pilot flame pattern is incorrect, as shown in Figure 38

- turn heater off (see *To Turn Off Gas to Appliance*, page 16)
- see *Troubleshooting*, pages 19 through 21

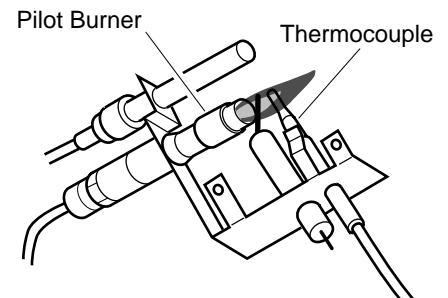

Figure 37 - Correct Pilot Flame Pattern

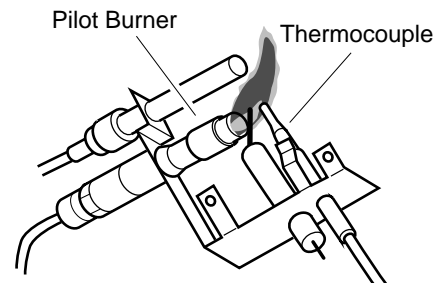

Figure 38 - Incorrect Pilot Flame Pattern

MAIN BURNER

Periodically inspect all burner flame holes with the heater running. All slotted burner flame holes should be open with yellow flame present. All round burner flame holes should be open with a small blue flame present. Some burner flame holes may become blocked by debris or rust, with no flame present. If so, turn off heater and let cool. Either remove blockage or replace burner. Blocked burner flame holes will create soot.

UNVENTED NATURAL GAS LOG HEATER

CLEANING AND MAINTENANCE

⚠ WARNING: Turn off heater and let cool before cleaning.

⚠ CAUTION: You must keep control areas, burner, and circulating air passageways of heater clean. Inspect these areas of heater before each use. Have heater inspected yearly by a qualified service person. Heater may need more frequent cleaning due to excessive lint from carpeting, bedding material, pet hair, etc.

CLEANING BURNER INJECTOR HOLDER AND PILOT AIR INLET HOLE

The primary air inlet holes allow the proper amount of air to mix with the gas. This provides a clean burning flame. Keep these holes clear of dust, dirt, lint, and pet hair. Clean these air inlet holes prior to each heating season. Blocked air holes will create soot. We recommend that you clean the unit every three months during operation and have heater inspected yearly by a qualified service person.

We also recommend that you keep the burner tube and pilot assembly clean and free of dust and dirt. To clean these parts we recommend using compressed air no greater than 30 PSI. Your local computer store, hardware store, or home center may carry compressed air in a can. You can use a vacuum cleaner in the blow position. If using compressed air in a can, please follow the directions on the can. If you don't follow directions on the can, you could damage the pilot assembly.

1. Shut off the unit, including the pilot. Allow the unit to cool for at least thirty minutes.
2. Inspect burner, pilot, and primary air inlet holes on injector holder for dust and dirt (see Figure 39).
3. Blow air through the ports/slots and holes in the burner.

4. Check the injector holder located at the end of the burner tube again. Remove any large particles of dust, dirt, lint, or pet hair with a soft cloth or vacuum cleaner nozzle.
5. Blow air into the primary air holes on the injector holder.
6. In case any large clumps of dust have now been pushed into the burner repeat steps 3 and 4.

Clean the pilot assembly also. A yellow tip on the pilot flame indicates dust and dirt in the pilot assembly. There is a small pilot air inlet hole about two inches from where the pilot flame comes out of the pilot assembly (see Figure 40). With the unit off, lightly blow air through the air inlet hole. You may blow through a drinking straw if compressed air is not available.

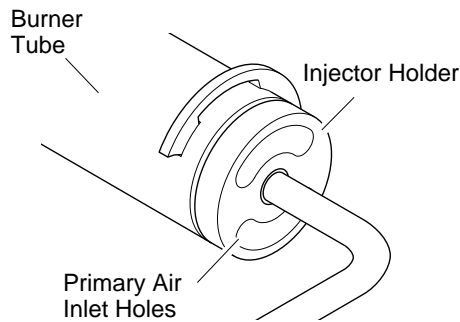

Figure 39 - Injector Holder On Outlet Burner Tube

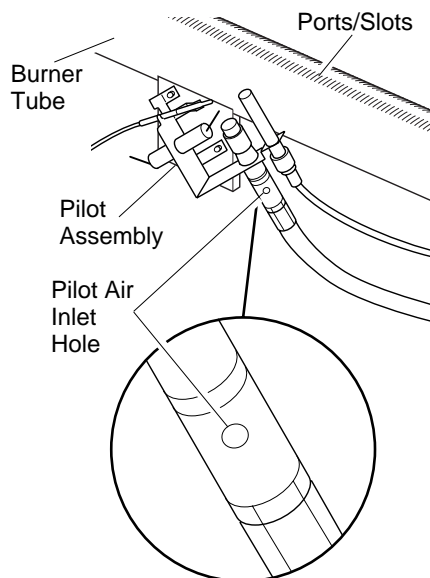

Figure 40 - Pilot Inlet Air Hole

LOGS

- If you remove logs for cleaning, refer to *Installing Logs*, pages 13 through 15, to properly replace logs.
- Replace log(s) if broken or chipped (dime-sized or larger).

MAIN BURNER

Periodically inspect all burner flame holes with the heater running. All slotted burner flame holes should be open with yellow flame present. All round burner flame holes should be open with a small blue flame present. Some burner flame holes may become blocked by debris or rust, with no flame present. If so, turn off heater and let cool. Either remove blockage or replace burner. Blocked burner flame holes will create soot.

SERVICE HINTS

When Gas Pressure Is Too Low

- pilot will not stay lit
- burners will have delayed ignition
- heater will not produce specified heat

When Gas Quality Is Bad

- pilot will not stay lit
- burners will produce flames and soot
- heater will backfire when lit

You may feel your gas pressure is too low or gas quality is bad. If so, contact your local natural gas supplier.

TECHNICAL SERVICE

You may have further questions about installation, operation, or troubleshooting.

If so, contact DESA International's Technical Service Department at 1-800-DESA LOG (1-800-337-2564).

You can also visit DESA International's technical service web site at www.desatech.com.

For information or questions concerning hand-held remote or receiver, contact Tracking Technology at 1-800-301-0440 or www.trackingtech.com.

TROUBLESHOOTING

Note: For additional help, visit DESA International's technical service web site at www.desatech.com.

Note: All troubleshooting items are listed in order of operation.

⚠ WARNING: Turn off heater and let cool before servicing. Only a qualified service person should service and repair heater.

⚠ CAUTION: Never use a wire, needle, or similar object to clean ODS/pilot. This can damage ODS/pilot unit.

OBSERVED PROBLEM	POSSIBLE CAUSE	REMEDY
When ignitor button is pressed, there is no spark at ODS/pilot	<ol style="list-style-type: none"> Ignitor electrode not connected to ignitor cable Ignitor cable pinched or wet Piezo ignitor nut is loose Broken ignitor cable Bad piezo ignitor Ignitor electrode broken Ignitor electrode positioned wrong 	<ol style="list-style-type: none"> Reconnect ignitor cable Free ignitor cable if pinched by any metal or tubing. Keep ignitor cable dry Tighten nut holding piezo ignitor to base panel of log set. Nut is located behind base panel Replace ignitor cable Replace piezo ignitor Replace piezo ignitor Replace piezo ignitor
When ignitor button is pressed, there is spark at ODS/pilot but no ignition	<ol style="list-style-type: none"> Gas supply turned off or equipment shutoff valve closed Control knob not in PILOT position Control knob not pressed in while in PILOT position Air in gas lines when installed ODS/pilot is clogged Gas regulator setting is not correct 	<ol style="list-style-type: none"> Turn on gas supply or open equipment shutoff valve Turn control knob to PILOT position Press in control knob while in PILOT position Continue holding down control knob. Repeat igniting operation until air is removed Clean ODS/pilot (see <i>Cleaning and Maintenance</i>, page 18) or replace ODS/pilot assembly Replace gas control
ODS/pilot lights but flame goes out when control knob is released	<ol style="list-style-type: none"> Control knob not fully pressed in Control knob not pressed in long enough Equipment shutoff valve not fully open Pilot flame not touching thermocouple, which allows thermocouple to cool, causing pilot flame to go out. This problem could be caused by one or both of the following: <ol style="list-style-type: none"> Low gas pressure Dirty or partially clogged ODS/pilot Thermocouple connection loose at control valve Thermocouple damaged Control valve damaged 	<ol style="list-style-type: none"> Press in control knob fully After ODS/pilot lights, keep control knob pressed in 30 seconds Fully open equipment shutoff valve <ol style="list-style-type: none"> Contact local natural gas company Clean ODS/pilot (see <i>Cleaning and Maintenance</i>, page 18) or replace ODS/pilot assembly Hand tighten until snug, then tighten 1/4 turn more Replace thermocouple Replace control valve



UNVENTED NATURAL GAS LOG HEATER

TROUBLESHOOTING

Continued

OBSERVED PROBLEM	POSSIBLE CAUSE	REMEDY
Burner does light after ODS/pilot is lit	<ol style="list-style-type: none">1. Burner orifice clogged2. Inlet gas pressure is too low3. Burner orifice diameter is too small4. Thermopile leads disconnected or improperly connected5. Burners will not come on in remote position	<ol style="list-style-type: none">1. Clean burner (see <i>Cleaning and Maintenance</i>, page 18) or replace burner orifice2. Contact local natural gas company3. Replace burner orifice4. Reconnect leads (see <i>Wiring Diagram</i>, page 27)5. Replace battery in transmitter and receiver
Delayed ignition burner	<ol style="list-style-type: none">1. Manifold pressure is too low2. Burner orifice clogged	<ol style="list-style-type: none">1. Contact local natural gas company2. Clean burner (see <i>Cleaning and Maintenance</i>, page 18) or replace burner orifice
Burner backfiring during combustion	<ol style="list-style-type: none">1. Burner orifice is clogged or damaged2. Damaged burner3. Gas regulator defective	<ol style="list-style-type: none">1. Clean burner (see <i>Cleaning and Maintenance</i>, page 18) or replace burner orifice2. Replace damaged burner3. Replace gas control
Slight smoke or odor during initial operation	<ol style="list-style-type: none">1. Not enough air2. Gas regulator defective3. Residues from manufacturing processes and logs curing	<ol style="list-style-type: none">1. Check burner for dirt and debris. If found, clean burner (see <i>Cleaning and Maintenance</i>, page 18)2. Replace gas control3. Problem will stop after a few hours of operation
Moisture/condensation noticed on windows	<ol style="list-style-type: none">1. Not enough combustion/ventilation air	<ol style="list-style-type: none">1. Refer to <i>Air for Combustion and Ventilation</i> requirements (page 4)
Heater produces a whistling noise when burner is lit	<ol style="list-style-type: none">1. Turning control knob to HI position when burner is cold2. Air in gas line3. Air passageways on heater blocked4. Dirty or partially clogged burner orifice	<ol style="list-style-type: none">1. Turn control knob to LO position and let warm up for a minute2. Operate burner until air is removed from line. Have gas line checked by local natural gas company3. Observe minimum installation clearances (see pages 7 through 9)4. Clean burner (see <i>Cleaning and Maintenance</i>, page 18) or replace burner orifice
White powder residue forming within burner box or on adjacent walls or furniture	<ol style="list-style-type: none">1. When heated, vapors from furniture polish, wax, carpet cleaners, etc. turn into white powder residue	<ol style="list-style-type: none">1. Turn heater off when using furniture polish, wax, carpet cleaners or similar products
Remote does not function	<ol style="list-style-type: none">1. Battery is not installed. Battery power is low	<ol style="list-style-type: none">1. Replace 9-volt batteries in receiver and remote control

TROUBLESHOOTING

Continued

- ⚠ WARNING: If you smell gas**
- **Shut off gas supply.**
 - **Do not try to light any appliance.**
 - **Do not touch any electrical switch; do not use any phone in your building.**
 - **Immediately call your gas supplier from a neighbor's phone. Follow the gas supplier's instructions.**
 - **If you cannot reach your gas supplier, call the fire department.**

IMPORTANT: Operating heater where impurities in air exist may create odors. Cleaning supplies, paint, paint remover, cigarette smoke, cements and glues, new carpet or textiles, etc., create fumes. These fumes may mix with combustion air and create odors. These odors will disappear over time.

OBSERVED PROBLEM	POSSIBLE CAUSE	REMEDY
Heater produces a clicking/ticking noise just after burner is lit or shut off	1. Metal expanding while heating or contracting while cooling	1. This is common with most heaters. If noise is excessive, contact qualified service person
Heater produces unwanted odors	1. Heater burning vapors from paint, hair spray, glues, cleaners, chemicals, new carpet, etc. (See <i>IMPORTANT</i> statement above) 2. Gas leak. See Warning statement at top of page	1. Open window and ventilate room. Stop using odor causing products while heater is running 2. Locate and correct all leaks (see <i>Checking Gas Connections</i> , page 12)
Heater shuts off in use (ODS operates)	1. Not enough fresh air is available 2. Low line pressure 3. ODS/pilot is partially clogged	1. Open window and/or door for ventilation 2. Contact local natural gas company 3. Clean ODS/pilot (see <i>Cleaning and Maintenance</i> , page 18)
Gas odor even when control knob is in OFF position	1. Gas leak. See Warning statement at top of page 2. Control valve defective	1. Locate and correct all leaks (see <i>Checking Gas Connections</i> , page 12) 2. Replace control valve
Gas odor during combustion	1. Foreign matter between control valve and burner 2. Gas leak. See Warning statement at top of page	1. Take apart gas tubing and remove foreign matter 2. Locate and correct all leaks (see <i>Checking Gas Connections</i> , page 12)

Comfort Glow®

UNVENTED NATURAL GAS LOG HEATER

ILLUSTRATED PARTS BREAKDOWN

CGD3924NRA

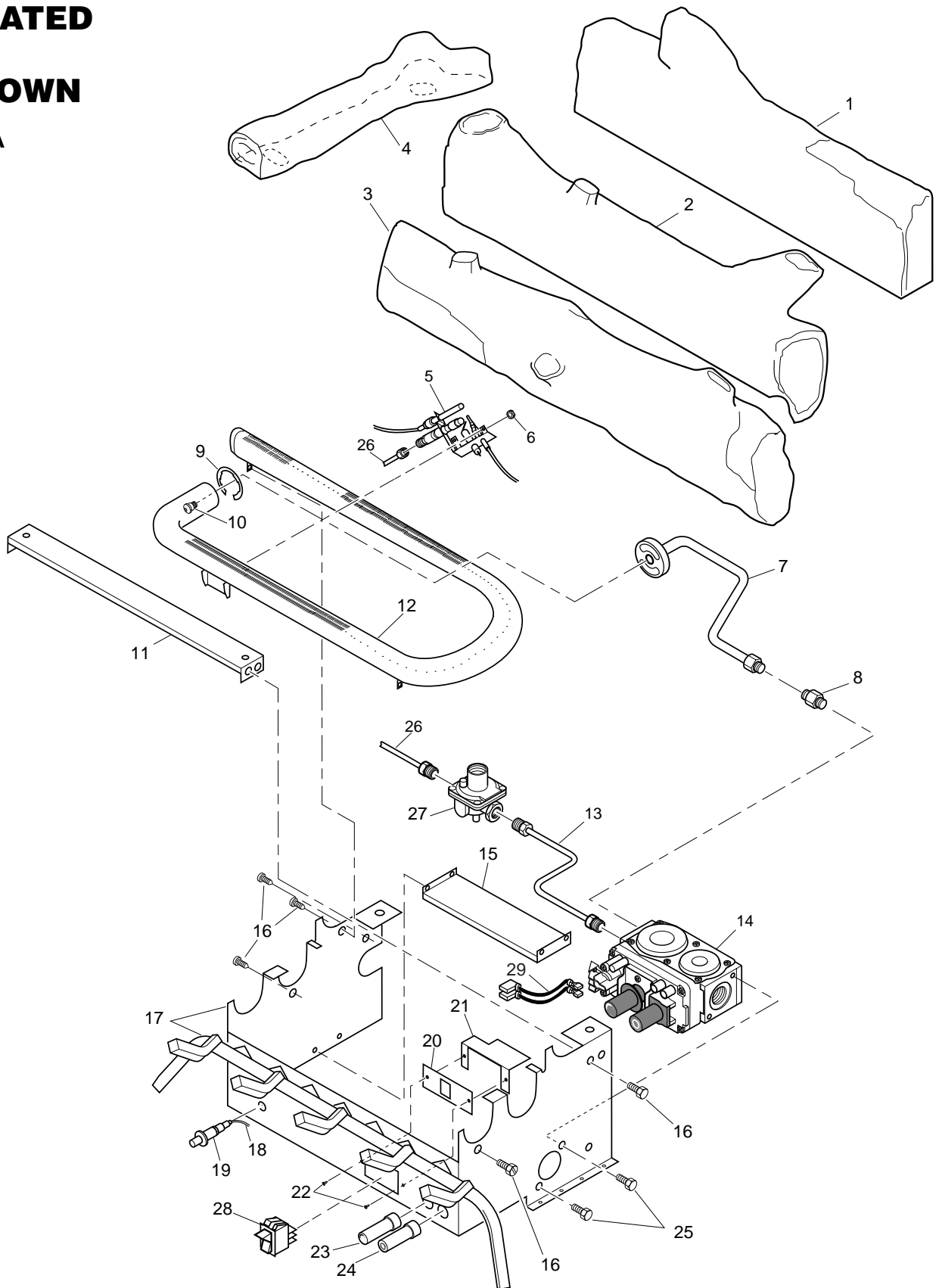

OWNER'S MANUAL

PARTS LIST

This list contains replaceable parts used in your heater. When ordering parts, follow the instructions listed under *Replacement Parts* on page 26 of this manual.

CGD3924NRA

KEY NO.	PART NUMBER	DESCRIPTION	QTY.
1	103008-01	Back Log (#1)	1
2	103009-01	Middle Log (#2)	1
3	103010-01	Front Log (#3)	1
4	103011-01	Crossover Log (#4)	1
5	103779-01	ODS Pilot (NG)	1
6	098249-01	ODS Nut	2
7	103342-01	Burner Outlet Tube	1
8	098264-02	Male Connector	1
9	102843-01	Burner Clip	1
10	099056-16	Burner Orifice Injector	1
11	102966-01	Upper Bracket	1
12	102772-01	Burner	1
13	099387-12	Pilot Tube (Valve to Regulator)	1
14	103781-01	Gas Control Valve	1
15	103345-01	Lower Bracket	1
16	M11084-38	Screw, #8 x .38	7
17	102775-06CK	Painted Base Assembly	1
18	098271-07	Ignitor Cable	1
19	102445-01	Piezo Ignitor	1
20	103587-02CK	Plate, Switch	1
21	104099-01	Heat Shield	1
22	098304-01	Screw	2
23	103784-02	Flame Adjustment Knob	1
24	103784-01	Off-Pilot-On Knob	1
25	M12461-26	Screw, Hex Slit Wsr 10-32 x .38	4
26	100609-01	Pilot Tube (Regulator to Pilot)	1
27	099918-02	Pilot Regulator	1
28	099998-01	Switch	1
29	103284-02	Wiring Harness	1
PARTS AVAILABLE — NOT SHOWN			
	100563-01	Warning Plate	1
	103877-01	Lighting Instructions Plate	1
	100565-01	Warning Plate Fastener	1
	100639-01	Caution Decal	1
	101137-02	Hardware Kit	1
	104310-09	Information Video	1
	GA6060	Lava Rock	1

Comfort Glow[®]

UNVENTED NATURAL GAS LOG HEATER

ILLUSTRATED PARTS BREAKDOWN

CCL3924NR
CCL3930NR

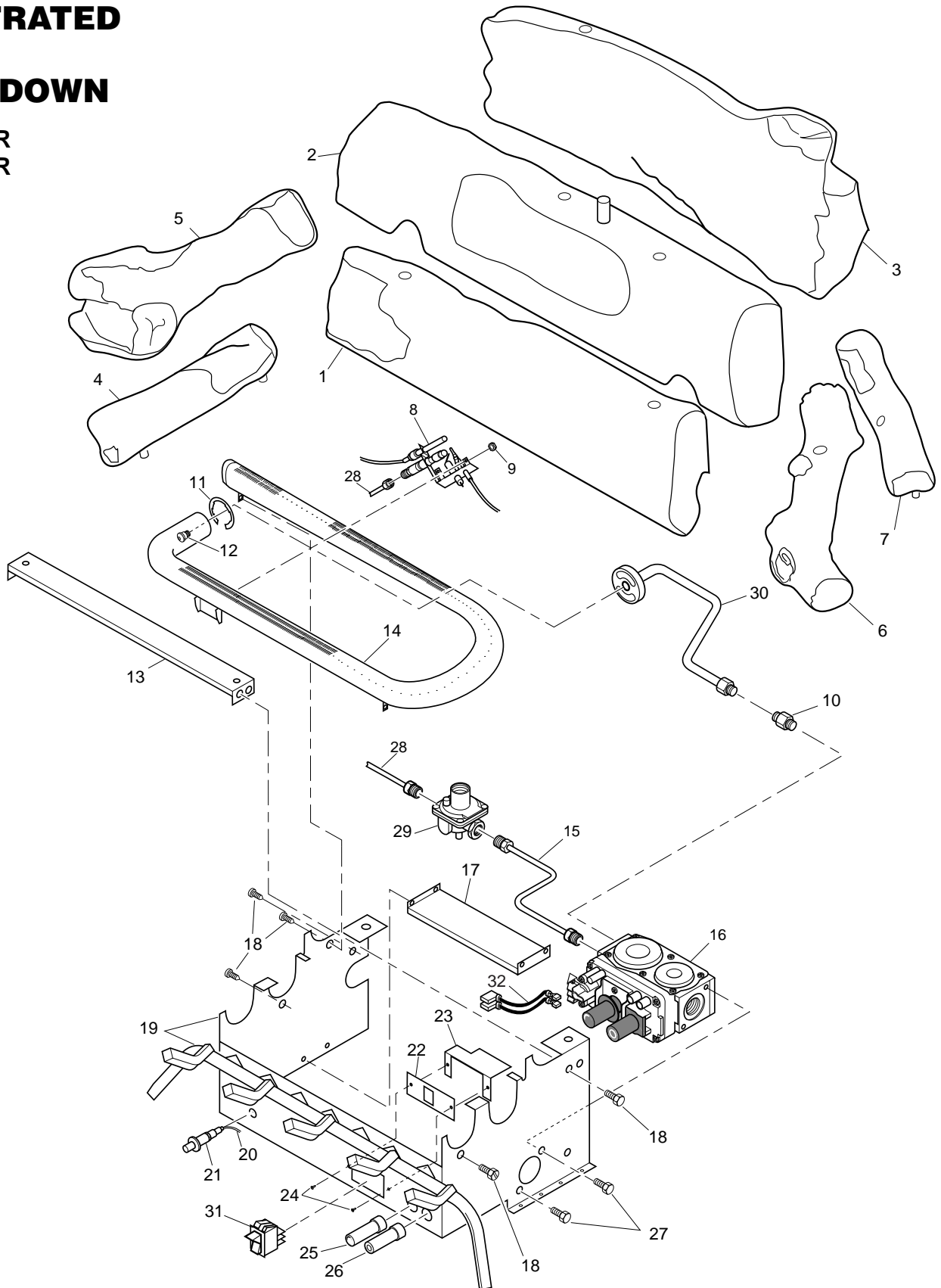

OWNER'S MANUAL

PARTS LIST

This list contains replaceable parts used in your heater. When ordering parts, follow the instructions listed under *Replacement Parts* on page 26 of this manual.

CCL3924NR
CCL3930NR

KEY NO.	CCL3924NR PART NUMBER	CCL3930NR PART NUMBER	DESCRIPTION	QTY.
1	105923-03	105923-02	Front Log (#1)	1
2	105924-03	105924-02	Middle Log (#2)	1
3	105925-03	105925-02	Back Log (#3)	1
4	105926-03	105926-02	Left Back Crossover Log (#4)	1
5	105927-03	105927-03	Left Top Crossover Log (#5)	1
6	105928-04	105928-02	Right Bottom Crossover Log (#6)	1
7	—	105929-02	Right Top Crossover Log (#7)	1
8	103779-01	103779-01	ODS Pilot (NG)	1
9	098249-01	098249-01	ODS Nut	2
10	098264-02	098264-02	Male Connector	1
11	102843-01	102843-01	Burner Clip	1
12	099056-16	099056-16	Burner Orifice Injector	1
13	102966-01	102966-01	Upper Bracket	1
14	102772-01	102772-01	Burner	1
15	099387-12	099387-12	Pilot Tube (Valve to Regulator)	1
16	103781-01	103781-01	Gas Control Valve	1
17	103345-01	103345-01	Lower Bracket	1
18	M11084-38	M11084-38	Screw, #8 x .38	7
19	102775-06CK	102775-06CK	Painted Base Assembly	1
20	098271-07	098271-07	Ignitor Cable	1
21	102445-01	102445-01	Piezo Ignitor	1
22	103587-02CK	103587-02CK	Plate, Switch	1
23	104099-01	104099-01	Heat Shield	1
24	098304-01	098304-01	Screw	2
25	103784-02	103784-02	Flame Adjustment Knob	1
26	103784-01	103784-01	Off-Pilot-On Knob	1
27	M12461-26	M12461-26	Screw, Hex Slit Wsr 10-32 x .38	4
28	100609-01	100609-01	Pilot Tube (Regulator to Pilot)	1
29	099918-02	099918-02	Pilot Regulator	1
30	103342-01	103342-01	Burner Outlet Tube	1
31	099998-01	099998-01	Switch	1
32	103284-02	103284-02	Wiring Harness	1
PARTS AVAILABLE — NOT SHOWN				
	100563-01	100563-01	Warning Plate	1
	103877-01	103877-01	Lighting Instructions Plate	1
	100565-01	100565-01	Warning Plate Fastener	1
	100639-01	100639-01	Caution Decal	1
	101137-02	101137-02	Hardware Kit	1
	104310-09	104310-09	Information Video	1
	GA6060	GA6060	Lava Rock	1



UNVENTED NATURAL GAS LOG HEATER

REPLACEMENT PARTS

Note: Use only original replacement parts. This will protect your warranty coverage for parts replaced under warranty.

PARTS UNDER WARRANTY

Contact authorized dealers of this product. If they can't supply original replacement part(s), call DESA International's Technical Service Department at 1-800-DESA LOG (1-800-337-2564).

When calling DESA International, have ready

- your name
- your address
- model and serial numbers of your heater
- how heater was malfunctioning
- type of gas used (propane/LP or natural gas)
- purchase date

Usually, we will ask you to return the defective part to the factory.

PARTS NOT UNDER WARRANTY

Contact authorized dealers of this product. If they can't supply original replacement part(s), either contact your nearest Parts Central or call DESA International's Parts Department at 1-800-972-7879 for referral information.

When calling DESA International, have ready

- model number of your heater
- the replacement part number

PARTS CENTRAL

These Parts Centrals are privately owned businesses. They have agreed to support our customer's needs by providing original replacement parts and accessories.

Baltimore Electric

1348 Dixwell Avenue
Hamden, CT 06514-0322
1-800-397-7553
203-248-7553
Parts Department

Portable Heater Parts

342 N. County Rd. 400 East
Valparaiso, IN 46383-9704
All States
219-462-7441
1-800-362-6951
sales@portableheaterparts.com
techservice@portableheaterparts.com

FBD

1349 Adams Street
Bowling Green, KY 42103-3414
270-846-1199
1-800-654-8534
Fax: 1-800-846-0090
franktalk@aol.com

Master Parts Dist.

1251 Mound Ave NW
Grand Rapids, MI 49504-2672
616-791-0505
1-800-446-1446
Fax: 616-791-8270
www.nbmc.com

Washer Equipment Co.

1715 Main Street
Kansas City, MO 64108-2195
KS, MO, AR
816-842-3911
www.washerparts.com

East Coast Energy Products

707 Broadway
W. Long Branch, NJ 07764-1542
732-870-8809
1-800-755-8809
www.njplaza.com/ecep

Heater & Fireplace Store

58 Halbe Lane
Cape May Court, NJ 08210-1110
609-390-9774
Parts Department

Dayton Hardware

P.O. Box 275
North Dayton Station
Dayton, OH 45404-0275
All States
937-258-3721
OH 1-800-762-3426

Halco Enterprises

208 Carter Drive, Unit 21
West Chester, PA 19382-4500
610-430-7717
1-800-368-0803
www.halcoenterprises.com

Laportes Parts & Service

2444 N. 5th Street
Hartsville, SC 29550-7704
803-332-0191
Parts Department

Cans Unlimited, Inc.

P.O. Box 645
Taylor, SC 29687-0013
All States
803-879-3009
1-800-845-5301
cuisales@aol.com

ACCESSORIES

Purchase these fireplace accessories from your local dealer. If they can not supply these accessories, either contact your nearest Parts Central (see page 26) or call DESA International's Sales Department at 1-800-972-7879 for referral information. You can also write to the address listed on the back page of this manual.

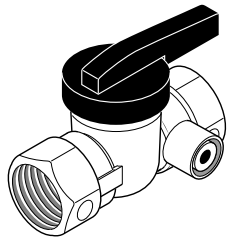

EQUIPMENT SHUTOFF VALVE - GA5010

Equipment shutoff valve with 1/8" NPT tap. Fits 1/2" NPT pipe.

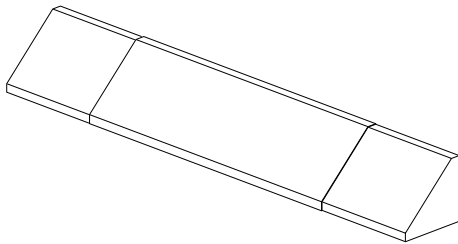

FIREPLACE HOOD

Black - GA6050

Brass - GA6052

Antique Brass - GA6053

Helps deflect heat away from mantel or wall above fireplace.

LAVA ROCK - GA6060 (Not Shown)

Order when additional rock is desired. (3 lb. bag)

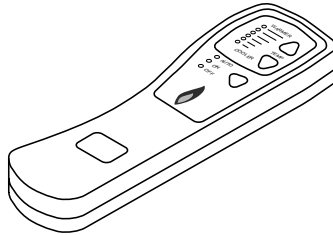

RECEIVER AND HAND-HELD THERMOSTAT REMOTE CONTROL KIT - CGHRCT SERIES

Allows the gas log heater to be operated in a manually or thermostatically-controlled mode. You can turn the gas log heater on and off without ever leaving the comfort of your easy chair.

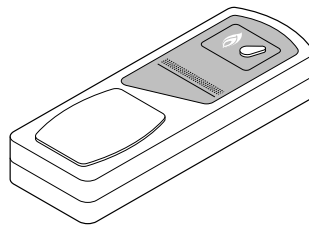

RECEIVER AND HAND-HELD REMOTE CONTROL KIT - CGHRC SERIES

Allows the gas log heater to be turned on and off by using a hand-held remote control.

DAMPER CLAMP - GA6080 (Not Shown)

Permanently opens chimney flue damper for vented operation. Can be used only with non-thermostat accessories.

SPECIFICATIONS

CGD3924NRA

Btu (Variable)	20,000/39,000
Type Gas	Natural Gas Only
Ignition	Piezo
Manifold Pressure	3.5" W.C.
Inlet Gas Pressure (in. of water)	
Maximum	10.5"
Shipping Weight	30 lbs.

CCL3924NR

Btu (Variable)	20,000/39,000
Type Gas	Natural Gas Only
Ignition	Piezo
Manifold Pressure	3.5" W.C.
Inlet Gas Pressure (in. of water)	
Maximum	10.5"
Shipping Weight	66 lbs.

CCL3930NR

Btu (Variable)	20,000/39,000
Type Gas	Natural Gas Only
Ignition	Piezo
Manifold Pressure	3.5" W.C.
Inlet Gas Pressure (in. of water)	
Maximum	10.5"
Shipping Weight	70 lbs.

WIRING DIAGRAM

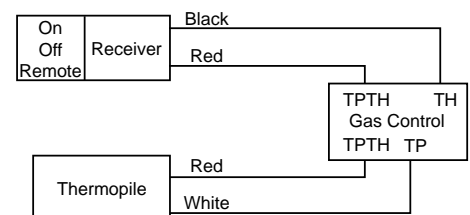

WARRANTY INFORMATION

KEEP THIS WARRANTY

Model _____
Serial No. _____
Date Purchased _____

Always specify model and serial numbers when communicating with the factory.

We reserve the right to amend these specifications at any time without notice. The only warranty applicable is our standard written warranty. We make no other warranty, expressed or implied.

LIMITED WARRANTY COMFORT GLOW VENT-FREE NATURAL GAS LOG HEATERS

DESA International warrants this product to be free from defects in materials and components for two (2) years from the date of first purchase, provided that the product has been properly installed, operated and maintained in accordance with all applicable instructions. To make a claim under this warranty the Bill of Sale or cancelled check must be presented.

This warranty is extended only to the original retail purchaser. This warranty covers the cost of part(s) required to restore this heater to proper operating condition and an allowance for labor when provided by a DESA Authorized Service Center. Warranty part(s) MUST be obtained through authorized dealers of this product and/or DESA International who will provide original factory replacement parts. Failure to use original factory replacement parts voids this warranty. The heater MUST be installed by a qualified installer in accordance with all local codes and instructions furnished with the unit.

This warranty does not apply to parts that are not in original condition because of normal wear and tear, or parts that fail or become damaged as a result of misuse, accidents, lack of proper maintenance or defects caused by improper installation. Travel, diagnostic cost, labor, transportation and any and all such other costs related to repairing a defective heater will be the responsibility of the owner.

TO THE FULL EXTENT ALLOWED BY THE LAW OF THE JURISDICTION THAT GOVERNS THE SALE OF THE PRODUCT; THIS EXPRESS WARRANTY EXCLUDES ANY AND ALL OTHER EXPRESSED WARRANTIES AND LIMITS THE DURATION OF ANY AND ALL IMPLIED WARRANTIES, INCLUDING WARRANTIES OF MERCHANTABILITY AND FITNESS FOR A PARTICULAR PURPOSE TO TWO (2) YEARS ON ALL COMPONENTS FROM THE DATE OF FIRST PURCHASE; AND DESA INTERNATIONAL'S LIABILITY IS HEREBY LIMITED TO THE PURCHASE PRICE OF THE PRODUCT AND DESA INTERNATIONAL SHALL NOT BE LIABLE FOR ANY OTHER DAMAGES WHATSOEVER INCLUDING INDIRECT, INCIDENTAL OR CONSEQUENTIAL DAMAGES.

Some states do not allow a limitation on how long an implied warranty lasts or an exclusion or limitation of incidental or consequential damages, so the above limitation on implied warranties, or exclusion or limitation on damages may not apply to you.

This warranty gives you specific legal rights, and you may also have other rights that vary from state to state.

For information about this warranty write:

DESA

INTERNATIONAL

2701 Industrial Drive

P.O. Box 90004

Bowling Green, KY 42102-9004

www.desatech.com



107553 01

NOT A UPC

107553-01
Rev. A
05/00