

MASTER[®]

PORTABLE FORCED AIR HEATERS OWNER'S MANUAL

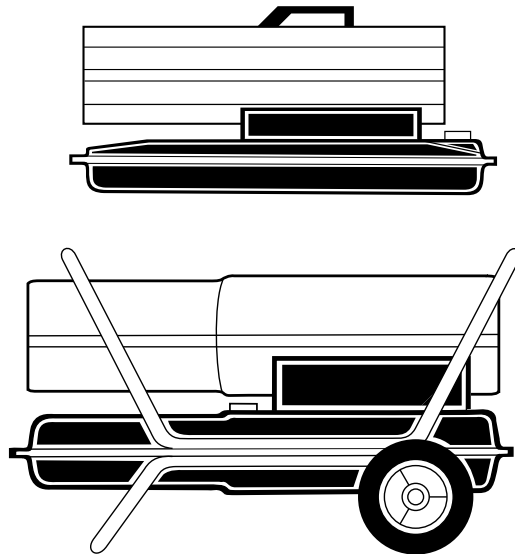

Heater Sizes: 35,000 70,000 100,000 150,000 Btu/Hr
Models: BY35CEH, BY70CEH, BY100CEH and BY150CEH

IMPORTANT: Read and understand this manual before assembling, starting or servicing heater. Improper use of heater can cause serious injury. Keep this manual for future reference.

TABLE OF CONTENTS

SAFETY INFORMATION	2	TROUBLESHOOTING	6
PRODUCT IDENTIFICATION	3	SERVICE PROCEDURES	8
UNPACKING	3	WIRING DIAGRAM	14
FUELS	3	SPECIFICATIONS	15
ASSEMBLY	4	ACCESSORIES	15
VENTILATION	4	ILLUSTRATED PARTS BREAKDOWN AND PARTS LIST	16
THEORY OF OPERATION	4	WHEELS AND HANDLES	24
OPERATION	5	EC CONFORMITY DECLARATION	25
STORING, TRANSPORTING, OR SHIPPING	5	WARRANTY AND REPAIR SERVICE	26
PREVENTATIVE MAINTENANCE SCHEDULE	6		



SAFETY INFORMATION

WARNINGS

IMPORTANT: Read this owner's manual carefully and completely before trying to assemble, operate, or service this heater. Improper use of this heater can cause serious injury or death from burns, fire, explosion, electrical shock, and carbon monoxide poisoning.

 DANGER: Carbon monoxide poisoning may lead to death!

Carbon Monoxide Poisoning: Early signs of carbon monoxide poisoning resemble the flu, with headaches, dizziness, and/or nausea. If you have these signs, the heater may not be working properly. **Get fresh air at once!** Have heater serviced. Some people are more affected by carbon monoxide than others. These include pregnant women, persons with heart or lung disease or anemia, those under the influence of alcohol, and those at high altitudes.

Make certain you read and understand all warnings. Keep this manual for reference. It is your guide to safe and proper operation of this heater.

- Use only kerosene or No. 1 fuel oil to avoid risk of fire or explosion. Never use gasoline, naphtha, paint thinners, alcohol, or other highly flammable fuels.
- Fueling
 - a) Personnel involved with fueling shall be qualified and thoroughly familiar with the manufacturer's instructions and applicable regulations regarding the safe fueling of heating units.
 - b) Only the type of fuel specified on the heater's data plate shall be used.
 - c) All flame, including the pilot light, if any, shall be extinguished and the heater allowed to cool, prior to fueling.
 - d) During fueling, all fuel lines and fuel-line connections shall be inspected for leaks. Any leaks shall be repaired prior to returning the heater to service.
 - e) At no time shall more than one day's supply of heater fuel be stored inside a building in the vicinity of the heater. Bulk fuel storage shall be outside the structure.
 - f) All fuel storage shall be located a minimum of 762cm (25 feet) from heaters, torches, welding equipment, and similar sources of ignition (exception: the fuel reservoir integral with the heater unit).
 - g) Whenever possible, fuel storage shall be confined to areas where floor penetrations do not permit fuel to drip onto or be ignited by a fire at lower elevation.
 - h) Fuel storage shall be in accordance with the authority having jurisdiction.
- Never use heater where gasoline, paint thinner, or other highly flammable vapors are present.
- Follow all local ordinances and codes when using heater.
- Heaters used in the vicinity of tarpaulins, canvas, or similar enclosure materials shall be located a safe distance from such materials. The recommended minimum safe distance is 304.8cm (10 feet). It is further recommended that these enclosure materials be of a fire retardant nature. These enclosure materials shall be securely fastened to prevent them from igniting or from upsetting the heater due to wind action.
- Use only in well-vented areas. Before using heater, provide at least a 2800 square cm (three-square-foot) opening of fresh, outside air for each 30 kw (100,000 Btu/Hr) of rating.
- Use only in places free of flammable vapors or high dust content.
- Use only the electrical voltage and frequency specified on model plate.
- Use only a three-prong, grounded extension cord.
- Minimum heater clearances from combustibles:
 - Outlet: 250 cm (8 Ft.)
 - Sides, Top, and Rear: 125 cm (4 Ft.)
- Locate heater on a stable and level surface if heater is hot or running or a fire may occur.
- When moving or storing heater, keep heater in a level position or fuel spillage may occur.
- Keep children and animals away from heater.
- Unplug heater when not in use.
- When used with thermostat, heater may start anytime.
- Never use heater in living or sleeping areas.
- Never block air inlet (rear) or air outlet (front) of heater.
- Never move, handle, refuel, or service a hot, operating, or plugged-in heater.
- Never attach duct work to front or rear of heater.

PRODUCT IDENTIFICATION

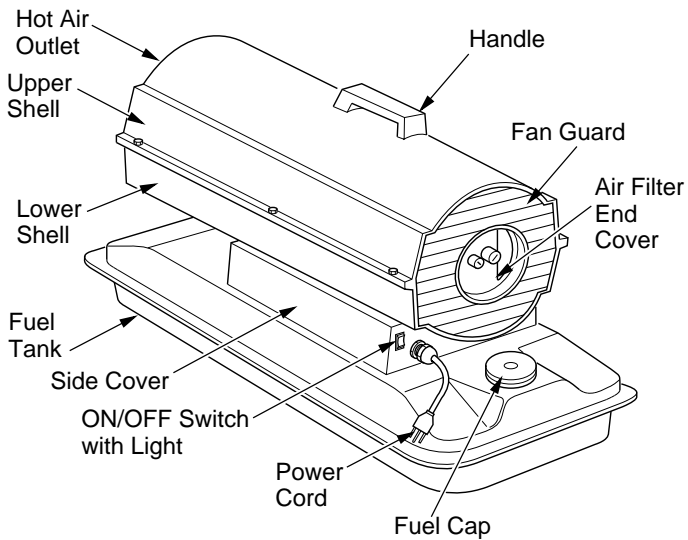

Figure 1 - BY35CEH and BY70CEH Models

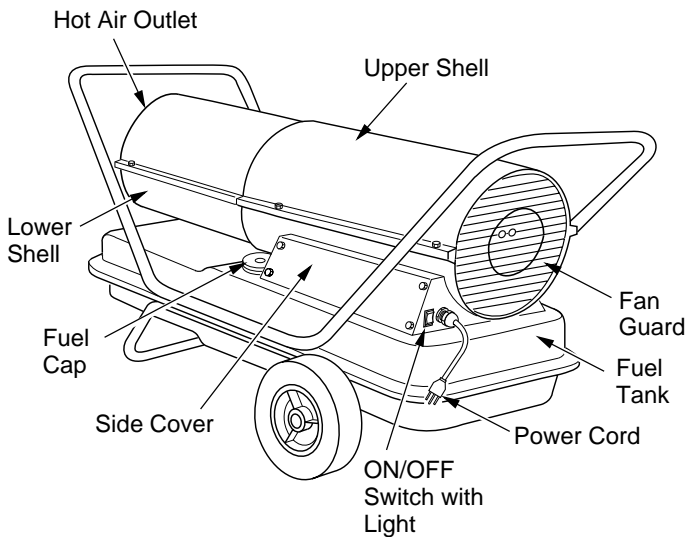

Figure 2 - BY100CEH and BY150CEH Models

UNPACKING

1. Remove all packing items applied to heater for shipment.
2. Remove all items from carton.
3. Check items for any shipping damage. If heater is damaged, promptly inform dealer where you bought heater.

FUELS

⚠ WARNING: Use only kerosene or No. 1 fuel oil to avoid risk of fire or explosion. Never use gasoline, naphtha, paint thinners, alcohol or other highly flammable fuels.

Do not use heavy fuels such as No. 2 fuel oil or No. 2 Diesel. Using heavy fuels will result in:

- clogged fuel filter and nozzle
- use of non-toxic anti-icer in fuel during very cold weather

IMPORTANT: Use a KEROSENE ONLY container. Be sure storage container is clean. Foreign matter such as rust, dirt, or water will cause the flame-out control to shut down heater. Foreign matter may also require you to clean fuel system often.

ASSEMBLY

(FOR BY100CEH AND BY150CEH MODELS ONLY)

These models are furnished with wheels and handles. Wheels, handles, and the mounting hardware are found in the shipping carton.

Tools Needed

- Medium Phillips Screwdriver
 - 3/8" Open or Adjustable Wrench
 - Hammer
1. Slide axle through wheel support frame. Install wheels on axle.
IMPORTANT: When installing wheels, point extended hub of wheels toward wheel support frame (see Figure 3).
 2. Place cap nuts on axle ends. Gently tap with hammer to secure.
 3. Place heater on wheel support frame. Make sure air inlet end (rear) of heater is over wheels. Line up holes on fuel tank flange with holes on wheel support frame.
 4. Place front handle and rear handle on top of fuel tank flange. Insert screws through handles, fuel tank flange, and wheel support frame. Attach nut finger tight after each screw is inserted.
 5. After all screws are inserted, tighten nuts firmly.

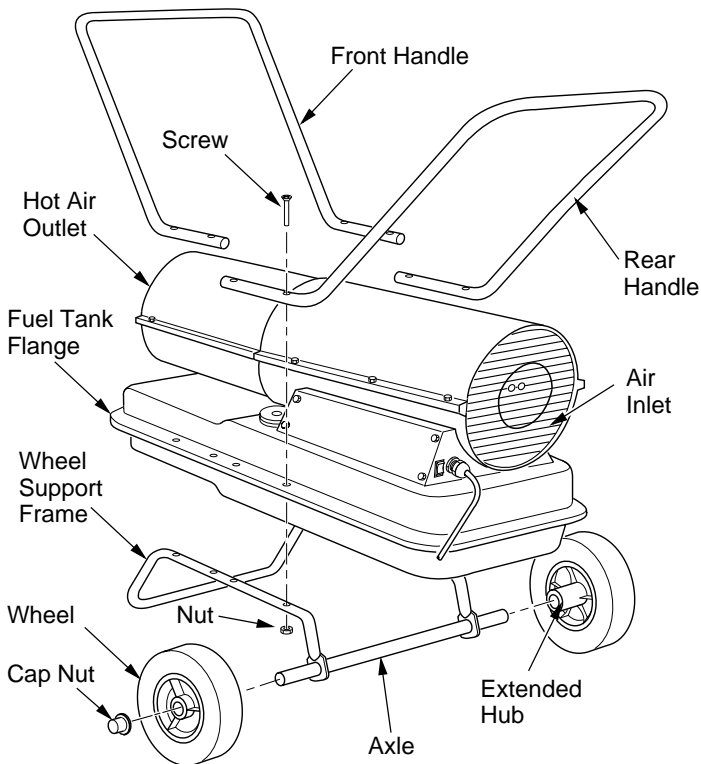

Figure 3 - Wheel and Handle Assembly

VENTILATION

⚠ WARNING: Follow the minimum fresh, outside air ventilation requirements. If proper fresh, outside air ventilation is not provided, carbon monoxide poisoning can occur. Provide proper fresh, outside air ventilation before running heater.

Provide a fresh air opening of at least 2800 square cm (three square feet) for each 30kw (100,000 Btu/Hr) rating. Provide extra fresh air if more heaters are being used.

Example: A 44kw (150,000 Btu/Hr) heater requires one of the following:

- a two-car garage door [4.9 meter (16 feet) opening] raised 9 cm (3.5 inches)
- a single-car garage door [2.75 meter (9 feet) opening] raised 15.25 cm (6 inches)
- two, 76 cm (30 inch) windows raised 28 cm (11 inches)

THEORY OF OPERATION

The Fuel System: The air pump forces air through the air line. The air is then pushed through the burner head nozzle. This air causes fuel to lift from the tank. A fine mist of fuel is sprayed into the combustion chamber.

The Air System: The motor turns the fan. The fan pushes air into and around the combustion chamber. This air is heated and provides a stream of clean, hot air.

The Ignition System: The ignition control assembly provides power to the ignitor. This ignites the fuel/air mixture in the combustion chamber.

The Flame-Out Control System: This system causes the heater to shut down if the flame goes out.

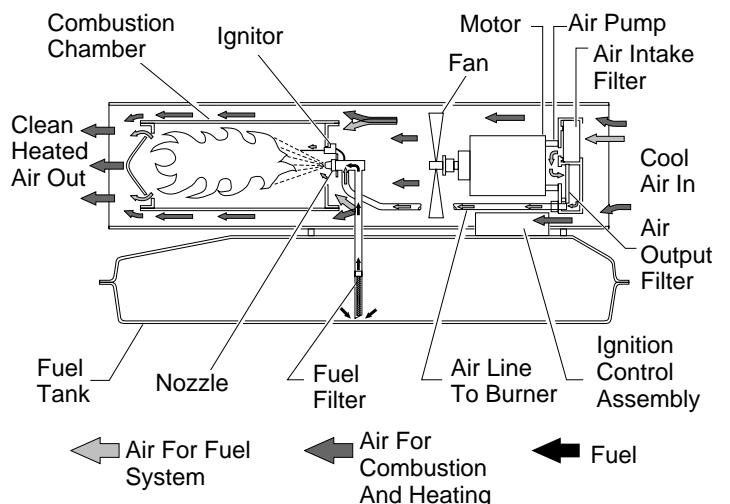

Figure 4 - Cross Section Operational View

OPERATION

⚠ WARNING: Review and understand the warnings in the *Safety Information* section, page 2. They are needed to safely operate this heater. Follow all local codes when using this heater.

TO START HEATER

1. Follow all ventilation and safety information.
2. Fill fuel tank with kerosene or No. 1 fuel oil.
3. Attach fuel cap.
4. Plug power cord of heater into standard 240 volt/50 hertz, grounded (earthed) outlet. Use an extension cord if needed. Use only a three-prong, grounded (earthed) extension cord.

EXTENSION CORD WIRE SIZE REQUIREMENTS

Up to 30.5 meters (100 feet) long, use 1.0 mm² (16 AWG) conductor

30.6 to 61 meters (101 to 200 feet) long, use 1.5 mm² (14 AWG) conductor

Push ON/OFF switch to ON (I) position and heater should start in 5 seconds. If ON/OFF switch light does not come on or heater does not start, see *Troubleshooting* (pages 6 and 7).

TO STOP HEATER

Push ON/OFF switch to OFF (O) position.

TO RESET HEATER

1. Push ON/OFF switch to OFF (O) position and wait 10 seconds (2 minutes if heater has been running).
2. Repeat steps under *To Start Heater*, above.

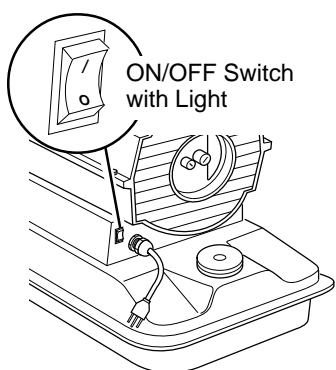

Figure 5 - ON/OFF Switch, BY35CEH and BY70CEH Models

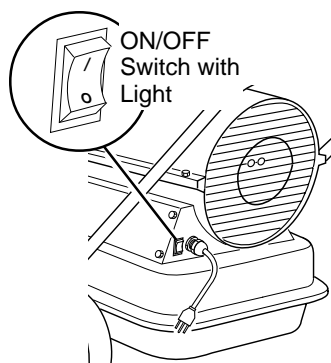

Figure 6 - ON/OFF Switch, BY100CEH and BY150CEH Models

STORING, TRANSPORTING, OR SHIPPING

Note: If shipping, transport companies require fuel tanks to be empty.

1. Drain fuel tank.

Note: Some models have drain plug on underside of fuel tank. If so, remove drain plug to drain all fuel. If heater does not have drain plug, drain fuel through fuel cap opening. Be sure all fuel is removed.

2. Replace drain plug if provided.
3. If any debris is noted in old fuel, add 1 or 2 quarts of clean kerosene to tank, stir, and drain again. This will prevent excess debris from clogging filters during future use.
4. Replace fuel cap or drain plug. Properly dispose of old and dirty fuel. Check with local automotive service stations that recycle oil.
5. If storing, store heater in dry place. Make sure storage place is free of dust and corrosive fumes.

IMPORTANT: Do not store kerosene over summer months for use during next heating season. Using old fuel could damage heater.

PREVENTATIVE MAINTENANCE SCHEDULE

⚠ WARNING: Never service heater while it is plugged in, operating, or hot. Severe burns and electrical shock can occur.

Item	How Often	How To
Fuel tank	Flush every 150-200 hours of operation or as needed	See <i>Storing, Transporting, or Shipping</i> , page 5
Air output and lint filters	Replace every 500 hours of operation or once a year	See <i>Air Output, Air Intake, and Lint Filters</i> , page 10
Air intake filter	Wash and dry with soap and water every 500 hours of operation or as needed	See <i>Air Output, Air Intake, and Lint Filters</i> , page 10
Fuel filter	Clean twice a heating season or as needed	See <i>Fuel Filter</i> , page 8
Ignitor	No maintenance required	
Fan blades	Clean every season or as needed	See <i>Fan</i> , page 13
Motor	Not required/permanently lubricated	

TROUBLESHOOTING

ATTENTION: The ignition control has built-in protection against current overloads. Use the light in the ON/OFF switch to troubleshoot the fault condition.

⚠ WARNING: Never service heater while it is plugged in, operating, or hot. Severe burns and electrical shock can occur.

FAULT CONDITION	POSSIBLE CAUSE	REMEDY
Motor does not start five seconds after heater is plugged in (ON/OFF switch light remains on)	<ol style="list-style-type: none"> 1. Bad electrical connection between motor and ignition control assembly or ignition control assembly and power cord 	<ol style="list-style-type: none"> 1. Check all electrical connections. See <i>Wiring Diagram</i>, page 14
	<ol style="list-style-type: none"> 2. Binding pump rotor 	<ol style="list-style-type: none"> 2. If fan does not turn freely, see <i>Pump Rotor</i>, page 12
	<ol style="list-style-type: none"> 3. Defective ignition control assembly 	<ol style="list-style-type: none"> 3. Replace ignition control assembly
	<ol style="list-style-type: none"> 4. Defective motor 	<ol style="list-style-type: none"> 4. Replace motor

⚠ WARNING: High voltage!

TROUBLESHOOTING

Continued

FAULT CONDITION	POSSIBLE CAUSE	REMEDY
Motor starts and runs but heater does not ignite (ON/OFF switch light remains on)	<ol style="list-style-type: none"> 1. No fuel in tank 2. Pump pressure incorrect 3. Dirty fuel filter 4. Obstruction in nozzle assembly 5. Water in fuel tank 	<ol style="list-style-type: none"> 1. Fill tank with kerosene 2. See <i>Pump Pressure Adjustment</i>, page 10 3. See <i>Fuel Filter</i>, page 8 4. See <i>Nozzle Assembly</i>, page 11 5. Drain and flush fuel tank with clean kerosene. See <i>Storing, Transporting, or Shipping</i>, page 5
⚠ WARNING: High voltage!		
Heater ignites but ignition control assembly shuts heater off after a short period of time (ON/OFF switch light remains on)	<ol style="list-style-type: none"> 6. Bad electrical connection between ignitor and ignition control assembly 7. Defective ignitor 8. Defective ignition control assembly 	<ol style="list-style-type: none"> 6. Check electrical connections. See <i>Wiring Diagram</i>, page 14 7. Replace ignitor, see page 9 8. Replace ignition control assembly
Heater ignites but ignition control assembly shuts heater off after a short period of time (ON/OFF switch light remains on)	<ol style="list-style-type: none"> 1. Pump pressure incorrect 2. Dirty air intake, air output, and/or lint filter 3. Dirty fuel filter 4. Obstruction in nozzle assembly 5. Photocell assembly not properly installed (not seeing the flame) 	<ol style="list-style-type: none"> 1. See <i>Pump Pressure Adjustment</i>, page 10 2. See <i>Air Output, Air Intake, and Lint Filters</i>, page 10 3. See <i>Fuel Filter</i>, page 8 4. See <i>Nozzle Assembly</i>, page 11 5. Make sure photocell boot is properly seated in bracket
⚠ WARNING: High voltage!		
ON/OFF switch light does not come on when switch is turned to the ON() position and heater does not start	<ol style="list-style-type: none"> 6. Dirty photocell lens 7. Bad electrical connection between photocell and ignition control assembly 8. Defective photocell 9. Defective ignition control assembly 	<ol style="list-style-type: none"> 6. Clean photocell lens 7. Check electrical connections. See <i>Wiring Diagram</i>, page 14 8. Replace photocell 9. Replace ignition control assembly
ON/OFF switch light does not come on when switch is turned to the ON() position and heater does not start	<ol style="list-style-type: none"> 1. No power to heater 	<ol style="list-style-type: none"> 1. Verify that power cord is plugged into an electrical outlet and that the circuit breaker in the electrical panel is reset
⚠ WARNING: High voltage!		
ON/OFF switch light does not come on when switch is turned to the ON() position and heater does not start	<ol style="list-style-type: none"> 2. Bad electrical connections 3. Electrical short in ignitor 	<ol style="list-style-type: none"> 2. Check electrical wiring and connections. See <i>Wiring Diagram</i>, page 14 3. Check ignitor wiring. If no problems are found, replace ignitor (see page 9)
ON/OFF switch light comes on when switch is turned to the ON() Position but turns off after five seconds	<ol style="list-style-type: none"> 1. Electrical short in motor 	<ol style="list-style-type: none"> 1. Check motor wiring. If no problems are found, replace motor
⚠ WARNING: High voltage!		

SERVICE PROCEDURES

⚠ WARNING: Never service heater while it is plugged in, operating, or hot. Severe burns and electrical shock can occur.

UPPER SHELL REMOVAL

1. Remove screws and lock washers along each side of heater using 5/16" nut-driver. These screws attach upper and lower shells together.
2. Lift upper shell off.
3. Remove fan guard.

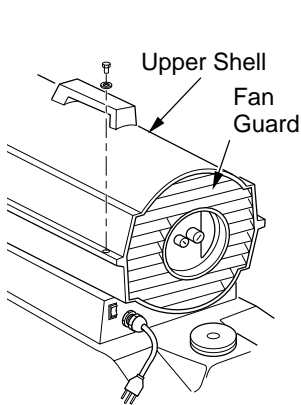

Figure 7 - Upper Shell Removal, BY35CEH and BY70CEH Models

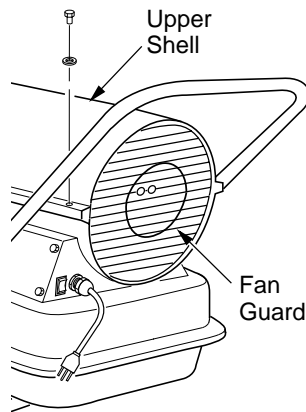

Figure 8 - Upper Shell Removal, BY100CEH and BY150CEH Models

FUEL FILTER (BY35CEH and BY70CEH Models)

1. Remove side cover screws using 5/16" nut-driver.
2. Remove side cover.
3. Pull rubber fuel line off fuel filter neck.
4. Carefully pry bushing and fuel filter out of fuel tank.
5. Wash fuel filter with clean fuel and replace in tank.
6. Attach rubber fuel line to fuel filter neck.
7. Replace side cover.

FUEL FILTER (BY100CEH and BY150CEH Models)

1. Remove side cover screws using 5/16" nut-driver.
2. Remove side cover.
3. Pull upper fuel line off fuel filter neck.
4. Carefully pry bushing, lower fuel line, and fuel filter out of fuel tank.
5. Wash fuel filter with clean fuel and replace in tank.
6. Attach upper fuel line to fuel filter neck.
7. Replace side cover.

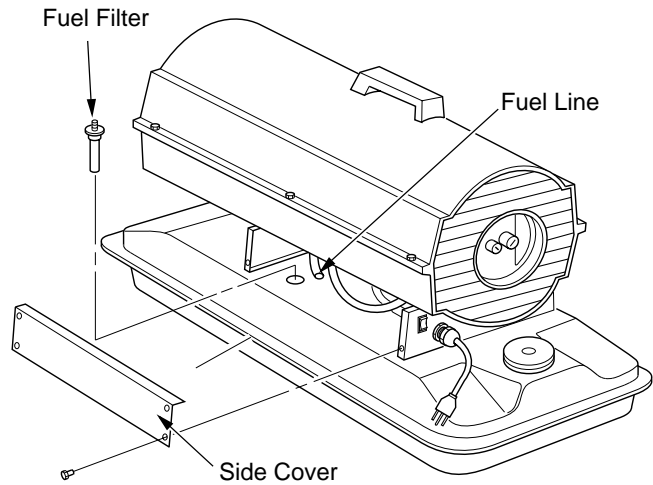

Figure 9 - Fuel Filter Removal, BY35CEH and BY70CEH Models

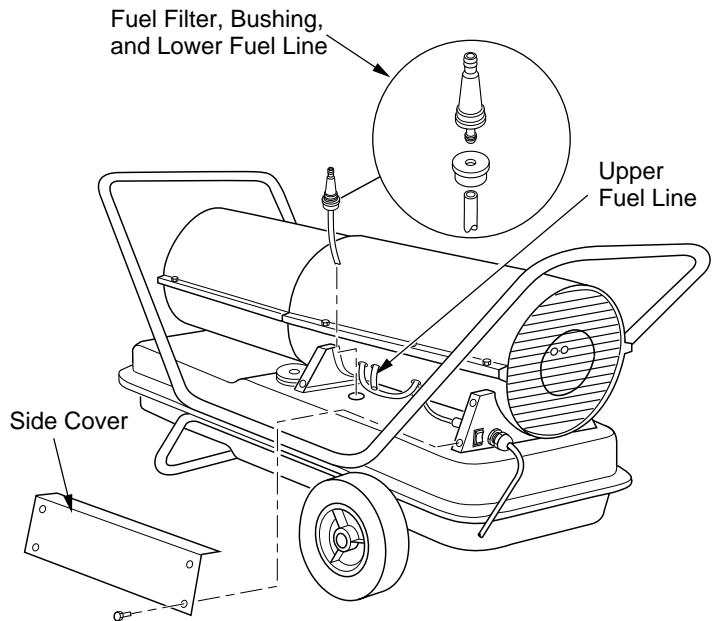

Figure 10 - Fuel Filter Removal, BY100CEH and BY150CEH Models

SERVICE PROCEDURES

Continued

IGNITOR

1. Remove upper shell and fan guard (see page 8).
2. Remove fan (see page 13).
3. Remove 4 side cover screws with a 5/16" nut driver. Remove side cover (see Figure 9 or 10, page 8).
4. Disconnect ignitor wires (black) from ignition control assembly (see Figure 11). Pull the ignitor wires up through the hole in the lower shell.
5. Disconnect fuel line hose and air line hose. Remove photocell from photocell bracket (see Figure 11).
6. Remove combustion chamber. Stand combustion chamber on end with nozzle adapter bracket on top (see Figure 12).
7. Remove ignitor screw with a 1/4" nut driver. Carefully remove ignitor from nozzle adapter bracket.
8. Carefully remove replacement ignitor from styrofoam packing.
9. Carefully guide ignitor into opening in nozzle adapter bracket. Do not strike ignitor element. Attach ignitor to nozzle adapter bracket with screw using a 1/4" nut driver (see Figure 12). Torque .90 to 1.69 N-m (8 to 15 in-lbs) Do not over torque.
10. Replace combustion chamber.
11. Route the ignitor wires back down through the hole in the lower shell. Connect wires to the ignition control assembly.
12. Replace side cover (see Figure 9 or 10, page 8).
13. Connect and route fuel line hose and air line hose to burner head. See *Fuel and Air Line Replacement and Proper Routing*, page 12.
14. Replace photocell in photocell bracket. Route wires as shown in either Figure 17, 18, or 19, page 11.
15. Replace fan (see page 13).
16. Replace fan guard and upper shell (see page 8).

CAUTION: Do not bend or strike ignitor element. Handle with care.

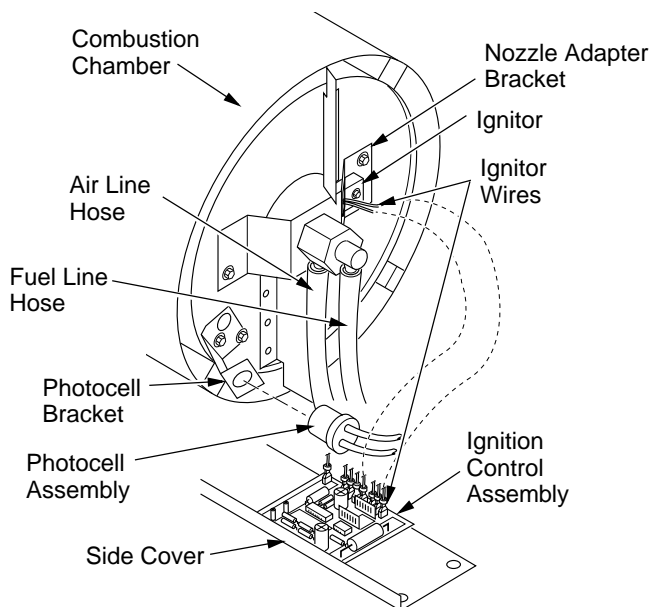

Figure 11 - Disconnecting Ignitor Wires from Ignition Control Assembly

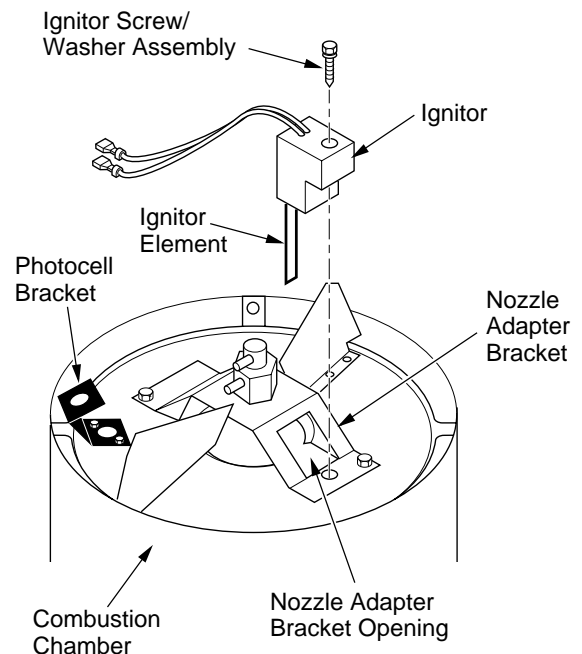

Figure 12 - Ignitor Replacement

SERVICE PROCEDURES

Continued

AIR OUTPUT, AIR INTAKE, AND LINT FILTERS

1. Remove upper shell (see page 8).
2. Remove filter end cover screws using 5/16" nut-driver.
3. Remove filter end cover.
4. Replace air output and lint filters.
5. Wash or replace air intake filter (see *Preventative Maintenance Schedule*, page 6).
6. Replace filter end cover.
7. Replace fan guard and upper shell.

IMPORTANT: Do not oil filters

PUMP PRESSURE ADJUSTMENT

1. Remove pressure gauge plug and plastic cap (BY35CEH and BY70CEH only) from filter end cover.
2. Install accessory pressure gauge (part number HA1180).
3. Start heater (see *Operation*, page 5). Allow motor to reach full speed.
4. Adjust pressure. Turn relief valve to right to increase pressure. Turn relief valve to left to decrease pressure. See specifications below for correct pressure for each model.
5. Remove pressure gauge. Replace pressure gauge plug and plastic cap (BY35CEH and BY70CEH only) in filter end cover.

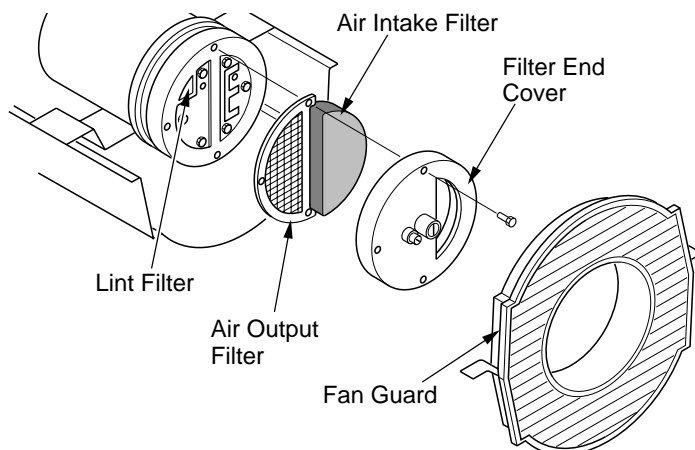

Figure 13 - Air Output, Air Intake, and Lint Filters, BY35CEH and BY70CEH Models

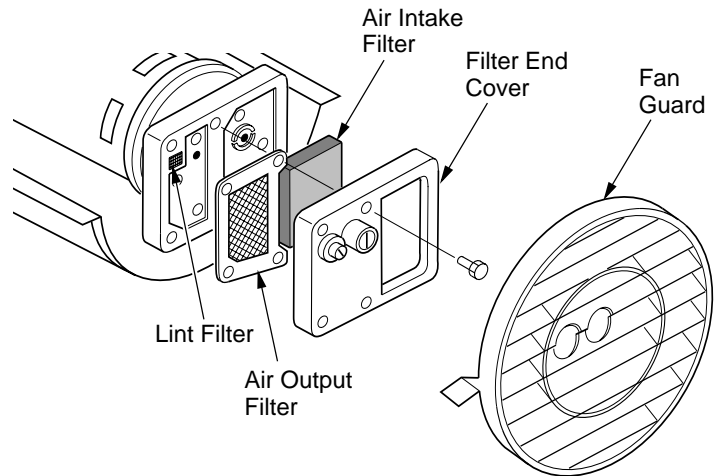

Figure 14 - Air Output, Air Intake, and Lint Filters, BY100CEH and BY150CEH Models

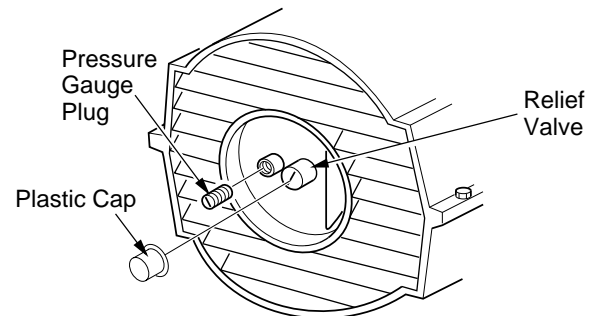

Figure 15 - Pressure Gauge Plug and Plastic Cap Removal

Model	Pump Pressure (PSI/Bar)
BY35CEH	2.9/0.200
BY70CEH	4.9/0.338
BY100CEH	4.9/0.338
BY150CEH	5.5/0.380

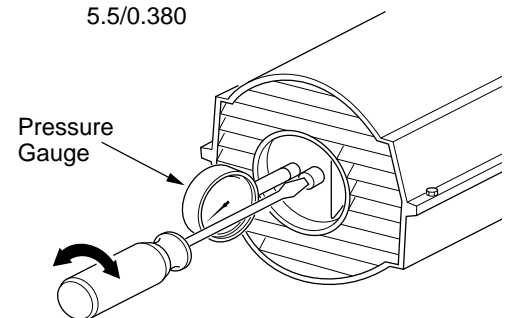

Figure 16 - Adjusting Pump Pressure

SERVICE PROCEDURES

Continued

NOZZLE ASSEMBLY

1. Remove upper shell (see page 8).
2. Remove fan (see page 13).
3. Remove fuel and air line hoses from nozzle assembly (see Figure 17, 18 or 19).
4. Turn nozzle assembly 1/4 turn to left and pull toward motor to remove (see Figure 20).
5. Place plastic hex-body into vise and lightly tighten.
6. Carefully remove nozzle from the nozzle adapter using 5/8" socket wrench (see Figure 21).
7. Blow compressed air through face of nozzle. This will free any dirt in nozzle area.
8. Inspect nozzle seal for damage.
9. Replace nozzle into nozzle adapter until nozzle seats. Tighten 1/3 turn more using 5/8" socket wrench 4.5 to 5.1 N-m (40 to 45 in-lbs). See Figure 21.
10. Attach nozzle assembly to burner strap.
11. Attach fuel and airline hoses to nozzle assembly. See *Fuel and Airline Replacement and Proper Routing*, page 12.
12. Replace fan (see page 13).
13. Replace fan guard and upper shell (see page 8).

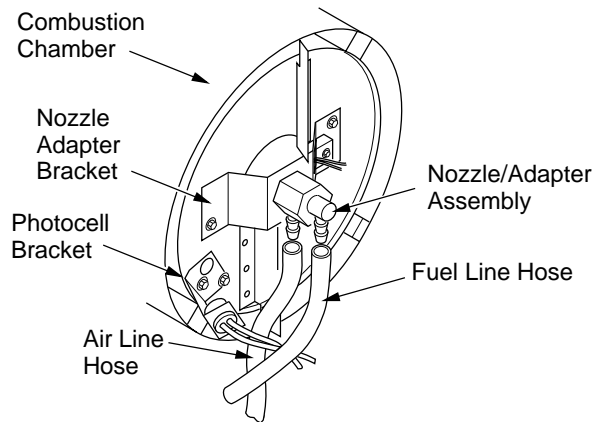

Figure 17 - Removing Air and Fuel Line Hoses (BY35CEH and BY70CEH Models Only)

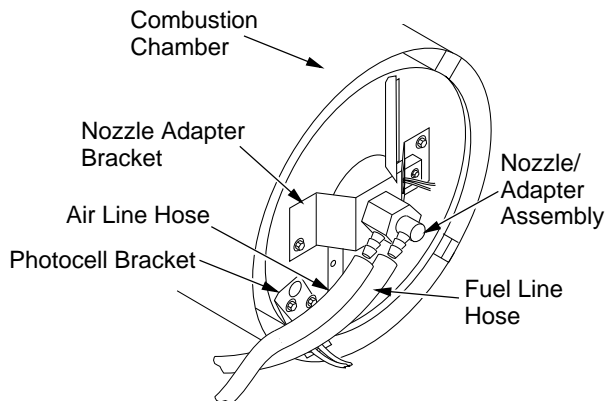

Figure 18 - Removing Air and Fuel Line Hoses (BY100CEH Model Only)

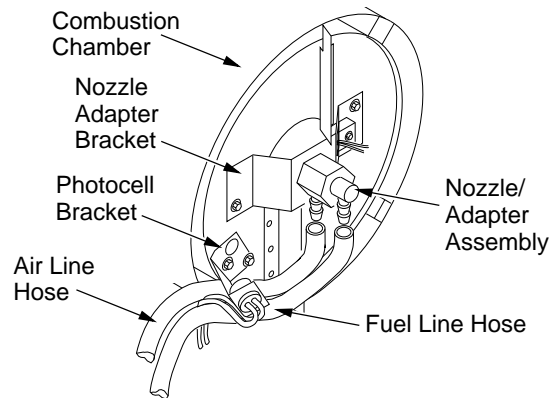

Figure 19 - Removing Air and Fuel Line Hoses (BY150CEH Model Only)

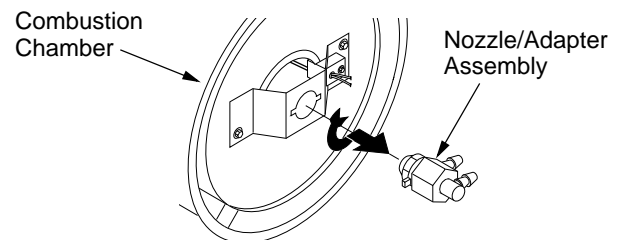

Figure 20 - Removing Nozzle/Adapter Assembly

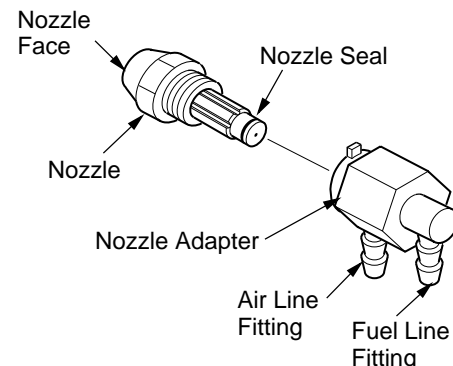

Figure 21 - Nozzle and Nozzle Adapter

SERVICE PROCEDURES

Continued

FUEL AND AIR LINE REPLACEMENT AND PROPER ROUTING

1. Remove upper shell (see page 8).
2. Remove side cover screws using 5/16" nut driver.
3. Remove side cover.
4. Inspect fuel and air line hoses for cracks and/or holes. If fuel line hose is damaged, disconnect from nozzle adapter (see Figure 17, 18, or 19, page 11) and from fuel filter (see page 8). If air line hose is damaged, disconnect from nozzle adapter (see Figure 17, 18, or 19, page 11) and from barb fitting on pump end cover (see Figure 22).
5. Install new air and/or fuel line. Attach one end of air line hose to barb fitting on pump end cover (see Figure 22) and the other end to nozzle adapter (see Figure 17, 18, or 19, page 11). Attach one end of fuel line hose to fuel filter (see page 8) and the other end to nozzle adapter (see Figure 17, 18, or 19, page 11).

For BY35CEH and BY70CEH model heaters, route air and fuel lines approximately as shown in Figure 17, page 11.

Note: Hoses are not to be touching photocell bracket.

For BY100CEH model heater, route air and fuel lines approximately as shown in Figure 18, page 11.

Note: Hoses are not to be touching photocell bracket.

For BY150CEH model heater, route air and fuel lines approximately as shown in Figure 19, page 11.

Note: Hoses are not to be touching photocell bracket

6. Replace side cover.
7. Replace upper shell and fan guard (see page 8).

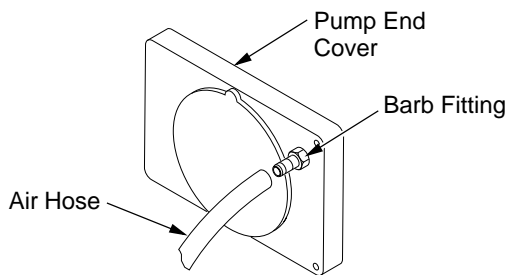

Figure 22 - Air Hose to Barb Fitting

PUMP ROTOR (Procedure if Rotor is Binding)

1. Remove upper shell (see page 8).
2. Remove filter end cover screws using 5/16" nut-driver.
3. Remove filter end cover and air filters.
4. Remove pump plate screws using 5/16" nut-driver.
5. Remove pump plate.
6. Remove rotor, insert, and blades.

7. Check for debris in pump. If debris is found, blow out with compressed air.
 8. Install insert and rotor.
 9. Check gap on rotor. Adjust to .076/.101 mm (.003"/.004") if needed (see Figure 25, page 13).
- Note:** Rotate rotor one full turn to ensure the gap is .076/.101 mm (.003"/.004") at tightest position. Adjust if needed.
10. Install blades, pump plate, air filters, and filter end cover.
 11. Replace fan guard and upper shell.
 12. Adjust pump pressure (see page 10).

Note: If rotor is still binding, proceed as follows.

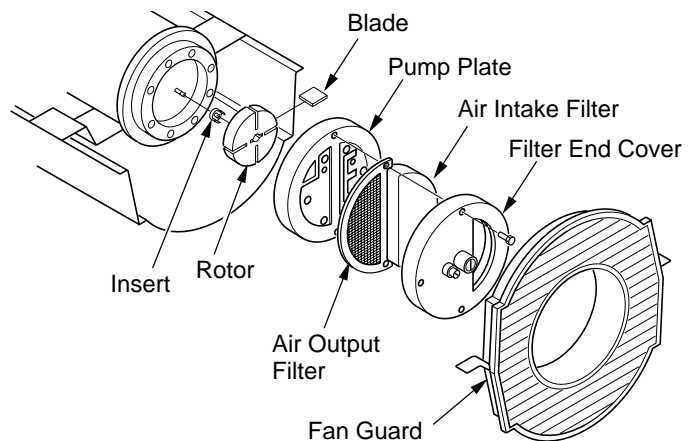

Figure 23 - Rotor Location, BY35CEH and BY70CEH Models

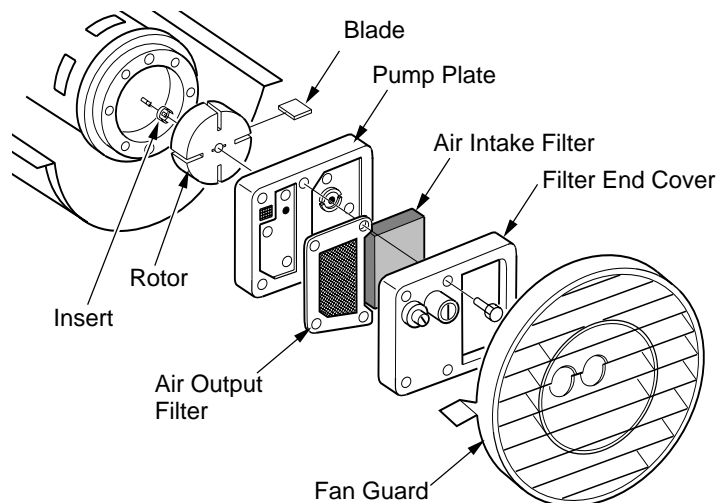

Figure 24 - Rotor Location, BY100CEH and BY150CEH Models

SERVICE PROCEDURES

Continued

13. Perform steps 1 through 6, page 12.
14. Place fine grade sandpaper (600 grit) on flat surface. Sand rotor lightly in "figure 8" motion four times (see Figure 26).
15. Reinstall insert and rotor.
16. Perform steps 10 through 12, page 12.

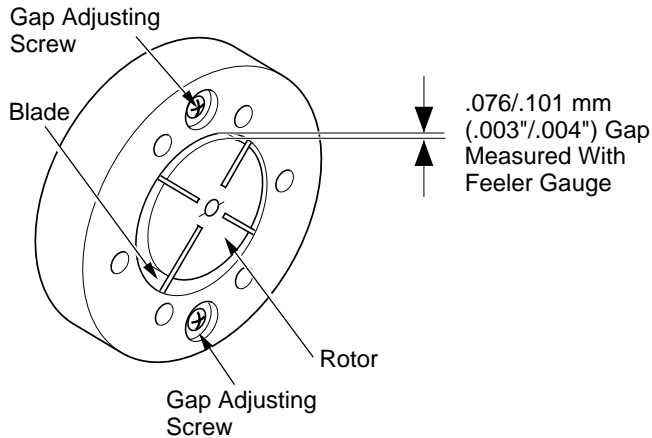

Figure 25 - Gap Adjusting Screw Locations

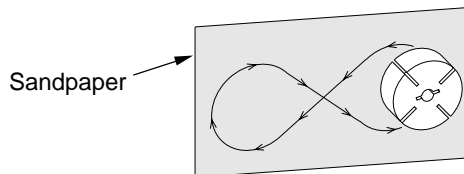

Figure 26 - Sanding Rotor

FAN

IMPORTANT: Remove fan from motor shaft before removing motor from heater. The weight of the motor resting on the fan could damage the fan pitch.

1. Remove upper shell (see page 8).
2. Use 1/8" allen wrench to loosen setscrew which holds fan to motor shaft.
3. Slip fan off motor shaft.
4. Clean fan using a soft cloth moistened with kerosene or solvent.
5. Dry fan thoroughly.
6. Replace fan on motor shaft. Place fan hub flush with end of motor shaft (see Figure 28).
7. Place setscrew on flat of shaft. Tighten setscrew firmly 4.5 to 5.6 N-m (40 to 50 in-lbs).
8. Replace fan guard and upper shell.

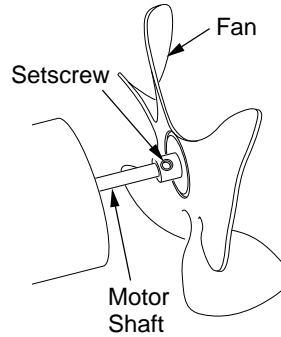

Figure 27 - Fan, Motor Shaft, and Setscrew Location

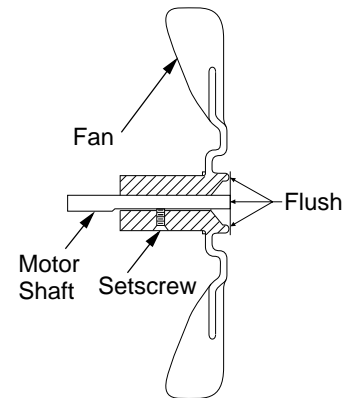

Figure 28 - Fan Cross Section

IGNITION CONTROL ASSEMBLY

WARNING: Unplug heater before servicing.

Remove Old Assembly

1. Using the 5/16" nut driver or socket wrench, remove the four side cover screws (see Figure 29).
2. Disconnect the nine wires from the ignition control assembly.
3. Using needle nose pliers, squeeze the tab on the printed circuit board support and lift up on the edge of the ignition control assembly (see Figure 30). Repeat this for the other four printed circuit board supports then remove the assembly.

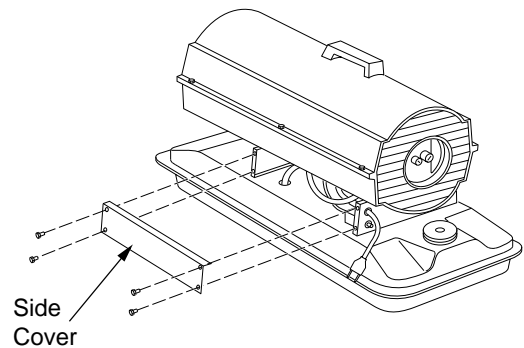

Figure 29 - Removing Cover

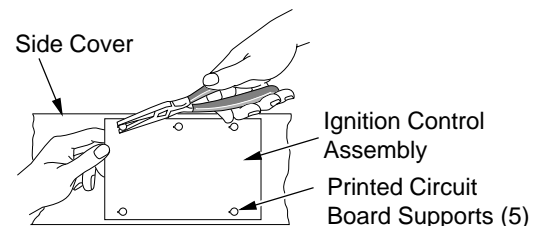

Figure 30 - Removing Circuit Board

SERVICE PROCEDURES

Continued

Installing the New Assembly

CAUTION: Ignition control assembly contains electrostatic components. Handle the assembly by the edges of the printed circuit board. Do not touch any of the quick connect terminals or electronic components.

1. Align the five holes in the assembly with the five printed circuit board supports in the side cover.
2. Holding the assembly by the edges of the printed circuit board, apply downward pressure until all five tabs on the printed circuit board supports springlock into place. Pull up on assembly to verify this (see Figure 31).
3. Connect the nine wire leads to the ignition control assembly as shown in the wiring diagram in column 2.

CAUTION: Double check connections. Connecting ignition control assembly wrong could result in damage to the ignition control assembly and/or other components in the heater assembly.

4. Using the 5/16" nut driver or socket wrench reinstall side cover to heater. Tighten screws until snug. Do not over torque!

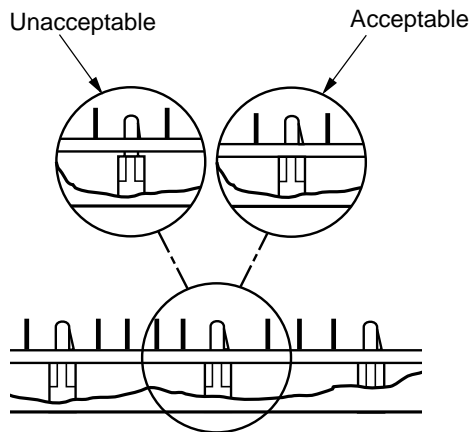
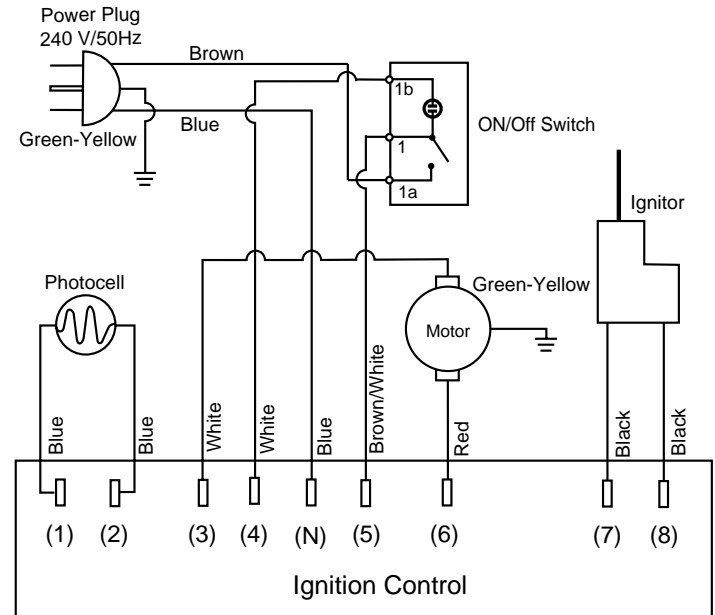

Figure 31 - Attaching Circuit Board to Tabs

WIRING DIAGRAM



SPECIFICATIONS

Output Rating (Btu/Hr\kw)	35,000 (10)	70,000 (20)	100,000 (30)	150,000 (44)
Fuel	Use Only Kerosene or No. 1 Fuel Oil			
Fuel Tank Capacity (U.S. Gal./Liters)	3.0/11.4	5.0/18.9	9.0/34	13.5/51.1
Fuel Consumption (Gal. Per Hr./Liters Per Hr.)	.28/1.1	.52/1.97	.79/3.0	1.1/4.1
Electric Requirements	240 V/50 Hz (Same All Models)			
Amperage (Normal Run)	.8	1.0	1.2	1.2
Hot Air Output (CFM/CMM)	140/4	225/6.4	425/12	500/14.2
Motor Speed (RPM)	1425	2850	2850	2850

ACCESSORIES

Purchase accessories from your local dealer.

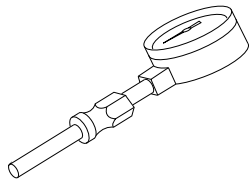

AIR GAUGE KIT - HA1180

For all models. Special tool to check pump pressure.

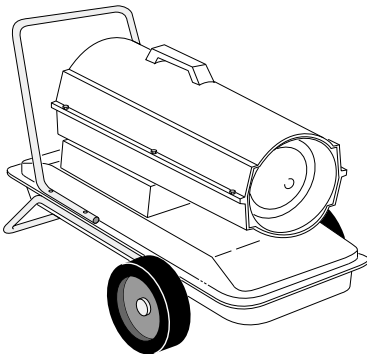

HEAVY DUTY WHEELS AND HANDLE KIT HA1202

For heavy duty applications. Makes your heater even more portable and convenient. For BY35CEH and BY70CEH models.

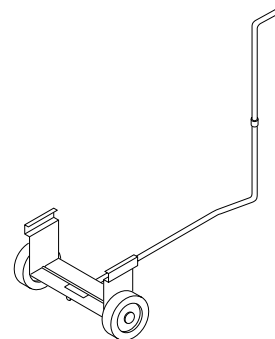

STANDARD WHEELS AND HANDLE KIT HA1206

Makes heater even more portable and convenient. Easy to assemble. For BY35CEH and BY70CEH models.

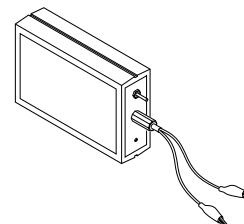

IGNITION CONTROL ASSEMBLY/ PHOTOCELL TESTER - HA1170

Special tool used to test the ignition control assembly and photocell.

ILLUSTRATED PARTS BREAKDOWN

BY35CEH MODEL

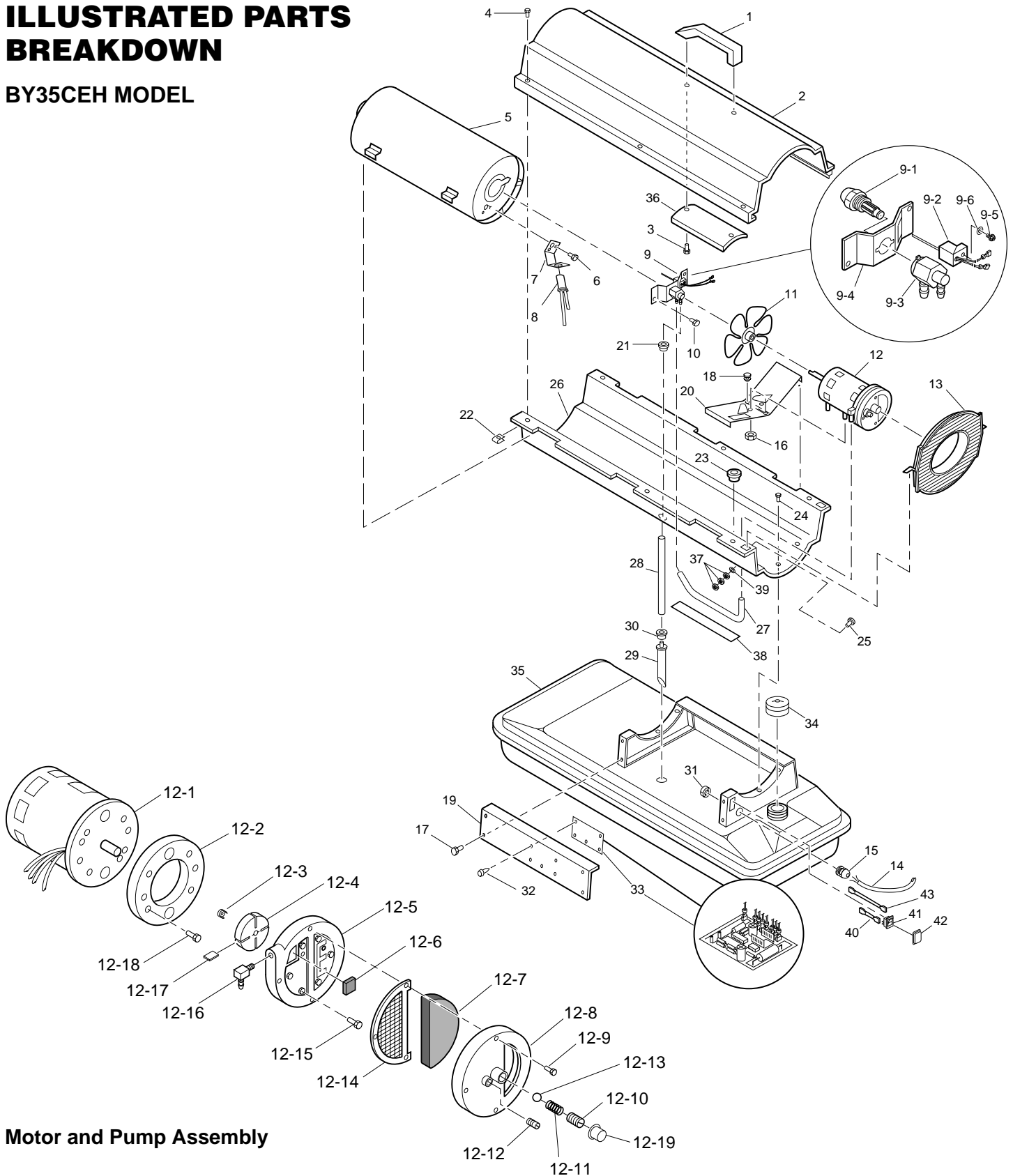

Motor and Pump Assembly

PARTS LIST

BY35CEH MODEL

This list contains replaceable parts used in your heater. When ordering parts, be sure to provide the correct model and serial numbers (from the model plate), then the part number and description of the desired part.

KEY NO.	PART NUMBER	DESCRIPTION	QTY.	KEY NO.	PART NUMBER	DESCRIPTION	QTY.
1	M51104-01	Handle	1	14	098872-04	Power Cord	1
2	098511-256	Upper Shell	1	15	M50400	Strain Relief Bushing	1
3	M11084-29	Screw, #10-16 x 3/4"	2	16	NTC-4C	Hex Lock Nut, 1/4-20	2
4	102432-01	Screw/Lockwasher, 1/2"	6	17	102431-01	Screw/Lockwasher, 1/2"	4
5	098512-63	Combustion Chamber	1	18	M50631	Rubber Bumper	2
6	M10908-2	Screw, #6-32 x 3/8"	2	19	097461-09	Side Cover	1
7	103154-03	Photocell Bracket	1	20	101205-01	Motor Bracket	1
8	M16656-24	Photocell Assembly	1	21	M30865-02	Bushing	1
9	**	Burner Strap Assembly	1	22	M11271-8	Clip Nut	6
9-1	HA3006	Nozzle Assembly	1	23	M50104-02	Bushing	1
9-2	102548-05	Ignitor Kit	1	24	102431-01	Screw/Lockwasher, 1/2"	6
9-3	104056-01	Nozzle Adapter	1	25	RF3-4B	Screw, #10-32 x 1/2"	1
9-4	102336-01	Nozzle Adapter Bracket	1	26	098511-237	Lower Shell	1
9-5	M10908-75	Screw, #6-32 x 7/8"	1	27	M50814-06	Rubber Airline	1
9-6	103347-01	Belleville Washer	1	28	M29652-05	Fuel Line	1
10	102431-01	Screw/Lockwasher, 1/2"	2	29	108060-01	Fuel Filter	1
11	103684-01	Fan	1	30	M10990-3	Rubber Bushing	1
12	**	Motor and Pump Assembly	1	31	102861-01	Nylon Locknut	1
12-1	102001-25	Motor	1	32	102349-01	PCB Support	5
12-2	079975-03	Pump Body	1	33	104068-04	Ignition Control Assembly	1
12-3	M22009	Insert	1	34	097702-01	Fuel Cap (Includes Gasket)	1
12-4	M22456-2	Rotor	1	35	108088-01	Fuel Tank	1
12-5	M29608	Pump End Cover	1	36	M51108-01	Shell Heat-Shield	1
12-6	M29632	Lint Filter	1	37	NPF-3B	Nut, #10-32	3
12-7	M29633	Intake Filter	1	38	097785-01	Vinyl Foam Gasket	1
12-8	M29609	Filter End Cover	1	39	WLE-3	Lockwasher, #10	1
12-9	M12461-31	Screw, #10-32 x 1"	3	40	079010-39	Wire Assembly (Brown/White)	1
12-10	M27694	Adjusting Screw	1	41	105793-01	ON/OFF Switch	1
12-11	M10993-1	Pressure Relief Spring	1	42	079919-01	Switch Cover	1
12-12	M22997	Plug	1	43	079010-40	Wire Assembly (White)	1
12-13	M8940	Steel Ball, 1/4" Diameter	1	PARTS AVAILABLE - NOT SHOWN			
12-14	M29612-01	Output Filter	1		HA2210	Filler Neck Screen	1
12-15	M12461-32	Screw #10-32 x 1 1/8"	6		103814-01	Wire Tie	1
12-16	103676-01	Nylon Elbow, 90°	1		097649-01	Tradename Decal	2
12-17	M8643-2	Blade	4		106013-01	Decal Package	1
12-18	FHPF3-6C	Screw, #10-32 x 3/4"	2		105880-01	Ignition Control Assembly Fuse	1
12-19	105780-01	Plastic Cap	1				
13	M51105-01	Fan Guard	1				

** Not available as an assembly; order parts separately

ILLUSTRATED PARTS BREAKDOWN

BY70CEH MODEL

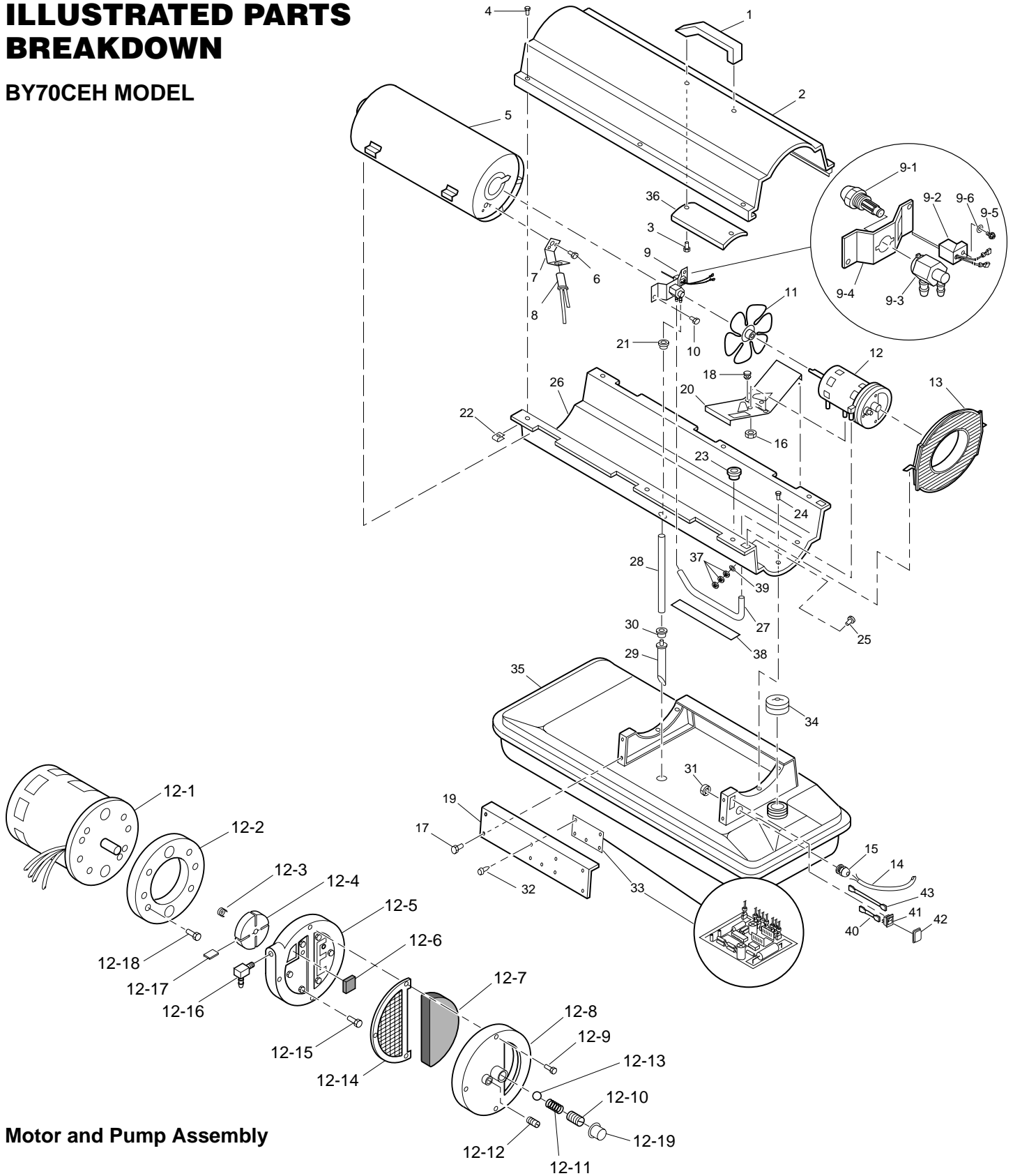

Motor and Pump Assembly

PARTS LIST

BY70CEH MODEL

This list contains replaceable parts used in your heater. When ordering parts, be sure to provide the correct model and serial numbers (from the model plate), then the part number and description of the desired part.

KEY NO.	PART NUMBER	DESCRIPTION	QTY.	KEY NO.	PART NUMBER	DESCRIPTION	QTY.
1	M51104-01	Handle	1	14	098872-04	Power Cord	1
2	098511-256	Upper Shell	1	15	M50400	Strain Relief Bushing	1
3	M11084-29	Screw, #10-16 x 3/4"	2	16	NTC-4C	Hex Lock Nut, 1/4-20	2
4	102432-01	Screw/Lockwasher, 1/2"	6	17	102431-01	Screw/Lockwasher, 1/2"	4
5	098512-64	Combustion Chamber	1	18	M50631	Rubber Bumper	2
6	M10908-2	Screw, #6-32 x 3/8"	2	19	097461-09	Side Cover	1
7	103154-03	Photocell Bracket	1	20	101205-01	Motor Bracket	1
8	M16656-24	Photocell Assembly	1	21	M30865-02	Bushing	1
9	**	Burner Strap Assembly	1	22	M11271-8	Clip Nut	6
9-1	HA3026	Nozzle Assembly	1	23	M50104-02	Bushing	1
9-2	102548-05	Ignitor Kit	1	24	102431-01	Screw/Lockwasher, 1/2"	6
9-3	104056-01	Nozzle Adapter	1	25	RF3-4B	Screw, #10-32 x 1/2"	1
9-4	102336-01	Nozzle Adapter Bracket	1	26	098511-237	Lower Shell	1
9-5	M10908-75	Screw, #6-32 x 7/8"	1	27	M50814-06	Rubber Airline	1
9-6	103347-01	Belleville Washer	1	28	M29652-05	Fuel Line	1
10	102431-01	Screw/Lockwasher, 1/2"	2	29	108060-03	Fuel Filter	1
11	103684-01	Fan	1	30	M10990-3	Rubber Bushing	1
12	**	Motor and Pump Assembly	1	31	102861-01	Nylon Locknut	1
12-1	102001-23	Motor	1	32	102349-01	PCB Support	5
12-2	079975-02	Pump Body	1	33	104068-04	Ignition Control Assembly	1
12-3	M22009	Insert	1	34	097702-01	Fuel Cap (Includes Gasket)	1
12-4	M22456-1	Rotor	1	35	108088-03	Fuel Tank	1
12-5	M29608	Pump End Cover	1	36	M51108-01	Shell Heat-Shield	1
12-6	M29632	Lint Filter	1	37	NPF-3B	Nut, #10-32	3
12-7	M29633	Intake Filter	1	38	097785-01	Vinyl Foam Gasket	1
12-8	M29609	Filter End Cover	1	39	WLE-3	Lockwasher, #10	1
12-9	M12461-31	Screw, #10-32 x 1"	3	40	079010-39	Wire Assembly (Brown/White)	1
12-10	M27694	Adjusting Screw	1	41	105793-01	ON/OFF Switch	1
12-11	M10993-1	Pressure Relief Spring	1	42	079919-01	Switch Cover	1
12-12	M22997	Plug	1	43	079010-40	Wire Assembly (White)	1
12-13	M8940	Steel Ball, 1/4" Diameter	1	PARTS AVAILABLE - NOT SHOWN			
12-14	M29612-01	Output Filter	1		HA2210	Filler Neck Screen	1
12-15	M12461-31	Screw #10-32 x 1"	6		103814-01	Wire Tie	1
12-16	103676-01	Nylon Elbow, 90°	1		097649-01	Tradename Decal	2
12-17	M8643	Blade	4		106013-02	Decal Package	1
12-18	FHPF3-5C	Screw, #10-32 x 5/8"	2		105880-01	Ignition Control Assembly Fuse	1
12-19	105780-01	Plastic Cap	1				
13	M51105-01	Fan Guard	1				

** Not available as an assembly; order parts separately

ILLUSTRATED PARTS BREAKDOWN

BY100CEH MODEL

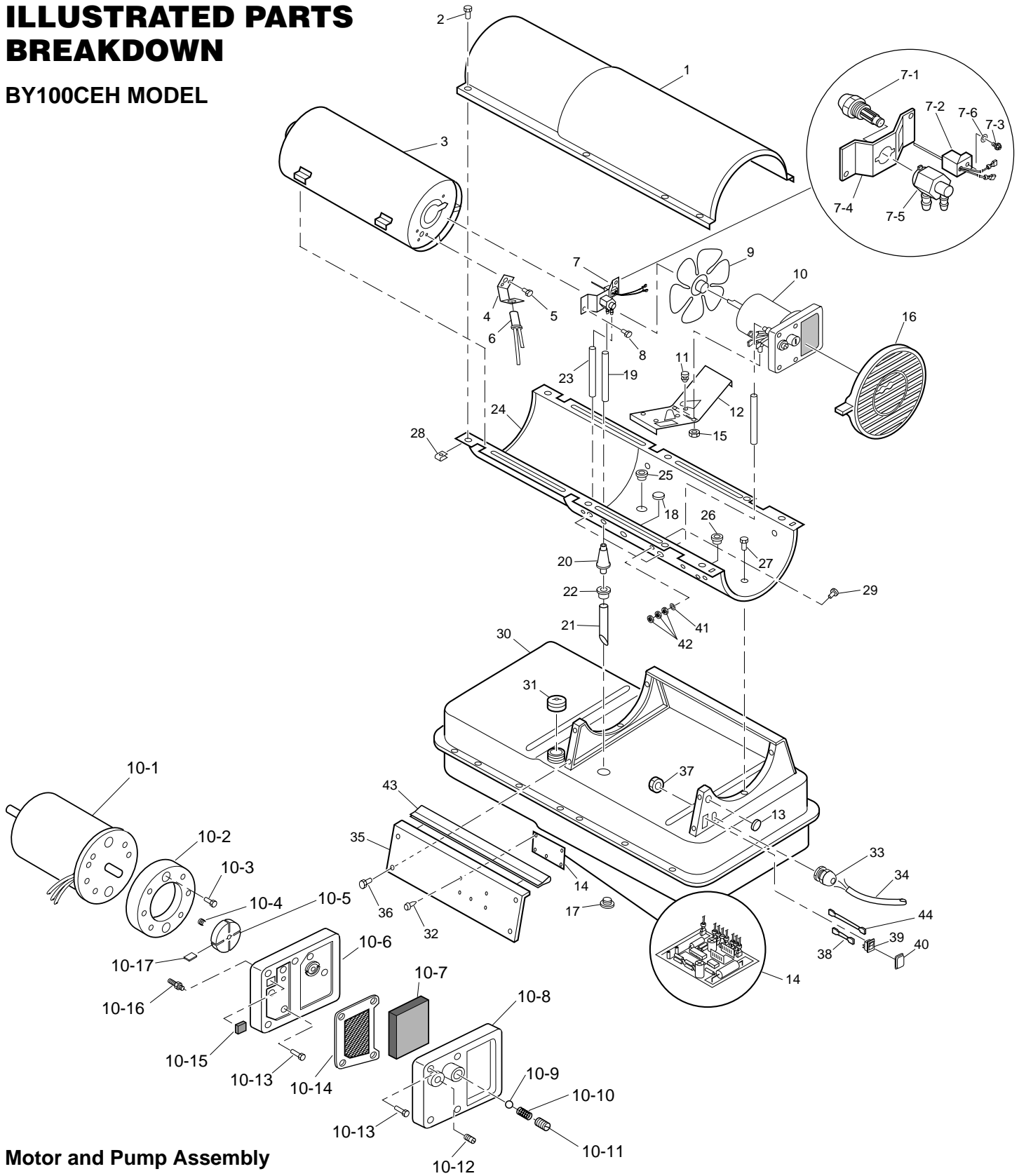

Motor and Pump Assembly

PARTS LIST
BY100CEH MODEL

This list contains replaceable parts used in your heater. When ordering parts, be sure to provide the correct model and serial numbers (from the model plate), then the part number and description of the desired part.

KEY NO.	PART NUMBER	DESCRIPTION	QTY.	KEY NO.	PART NUMBER	DESCRIPTION	QTY.
1	098511-257	Upper Shell	1	15	NTC-4C	Hex Lock Nut, 1/4-20	2
2	102432-01	Screw/Lockwasher, 1/2"	8	16	M51114-01	Fan Guard	1
3	098512-65	Combustion Chamber	1	17	M27417	Drain Plug (Includes "o" Ring)	1
4	103971-01	Photocell Bracket	1	18	099213-01	Button Plug	1
5	M10908-2	Screw, #6-32 x 3/8"	2	19	M51345-01	Fuel Line	1
6	M16656-24	Photocell Assembly	1	20	107961-01	Fuel Filter	1
7	**	Burner Strap Assembly	1	21	M51151-01	Fuel Line Tube	1
7-1	HA3027	Nozzle Assembly	1	22	M10990-3	Rubber Bushing	1
7-2	102548-05	Ignitor Kit	1	23	M50814-03	Airline	1
7-3	M10908-75	Screw, #6-32 x 7/8"	1	24	098511-236	Lower Shell	1
7-4	102336-01	Nozzle Adapter Bracket	1	25	M50104-03	Bushing	1
7-5	104054-01	Nozzle Adapter	1	26	M50104-01	Bushing	1
7-6	103347-01	Belleville Washer	1	27	102431-01	Screw/Lockwasher, 1/2"	6
8	102431-01	Screw/Lockwasher, 1/2"	2	28	M11271-8	Clip Nut	8
9	102042-01	Fan	1	29	RF3-4B	Screw, #10-32 x 1/2"	1
10	**	Motor and Pump Assembly	1	30	108088-04	Fuel Tank	1
10-1	102001-24	Motor	1	31	097702-01	Fuel Cap (Includes Gasket)	1
10-2	079975-02	Pump Body	1	32	102349-01	P.C. Board Support	5
10-3	FHPF3-5C	Screw, #10-32 x 5/8"	2	33	M50400	Strain Relief Bushing	1
10-4	M22009	Rotor Insert	1	34	098872-04	Power Cord	1
10-5	M22456-1	Pump Rotor	1	35	M51077-15	Side Cover	1
10-6	M50545	Pump End Cover	1	36	102431-01	Screw/Lockwasher, 1/2"	4
10-7	M12179	Intake Filter	1	37	102861-01	Nylon Locknut	1
10-8	M16545	Filter End Cover	1	38	079010-39	Wire Assembly (Brown/White)	1
10-9	M8940	Steel Ball, 1/4" Diameter	1	39	105793-01	ON/OFF Switch	1
10-10	M10993-1	Relief Spring	1	40	079919-01	Switch Cover	1
10-11	M27694	Adjusting Screw	1	41	WLE-3	Lockwasher, #10	1
10-12	M22997	Plug	1	42	NPF-3B	Nut, #10-32	3
10-13	M12461-31	Screw, #10-32 x 1"	10	43	097468-01	Edge Liner	1
10-14	M12244-1	Output Filter	1	44	079010-40	Wire Assembly (White)	1
10-15	M11637	Lint Filter	1	PARTS AVAILABLE - NOT SHOWN			
10-16	M50820-02	Barb Fitting	1		HA2210	Filler Neck Screen	1
10-17	M8643	Blade	4		103814-01	Wire Tie	1
11	M50631	Rubber Bumper	2		097650-01	Tradename Decal	2
12	101206-01	Motor Mounting Bracket	1		106013-03	Decal Package	1
13	101695-01	Button Plug	1		105880-01	Ignition Control Assembly Fuse	1
14	104068-04	Ignition Control Assembly	1				

** Not available as an assembly; order parts separately

ILLUSTRATED PARTS BREAKDOWN

BY150CEH MODEL

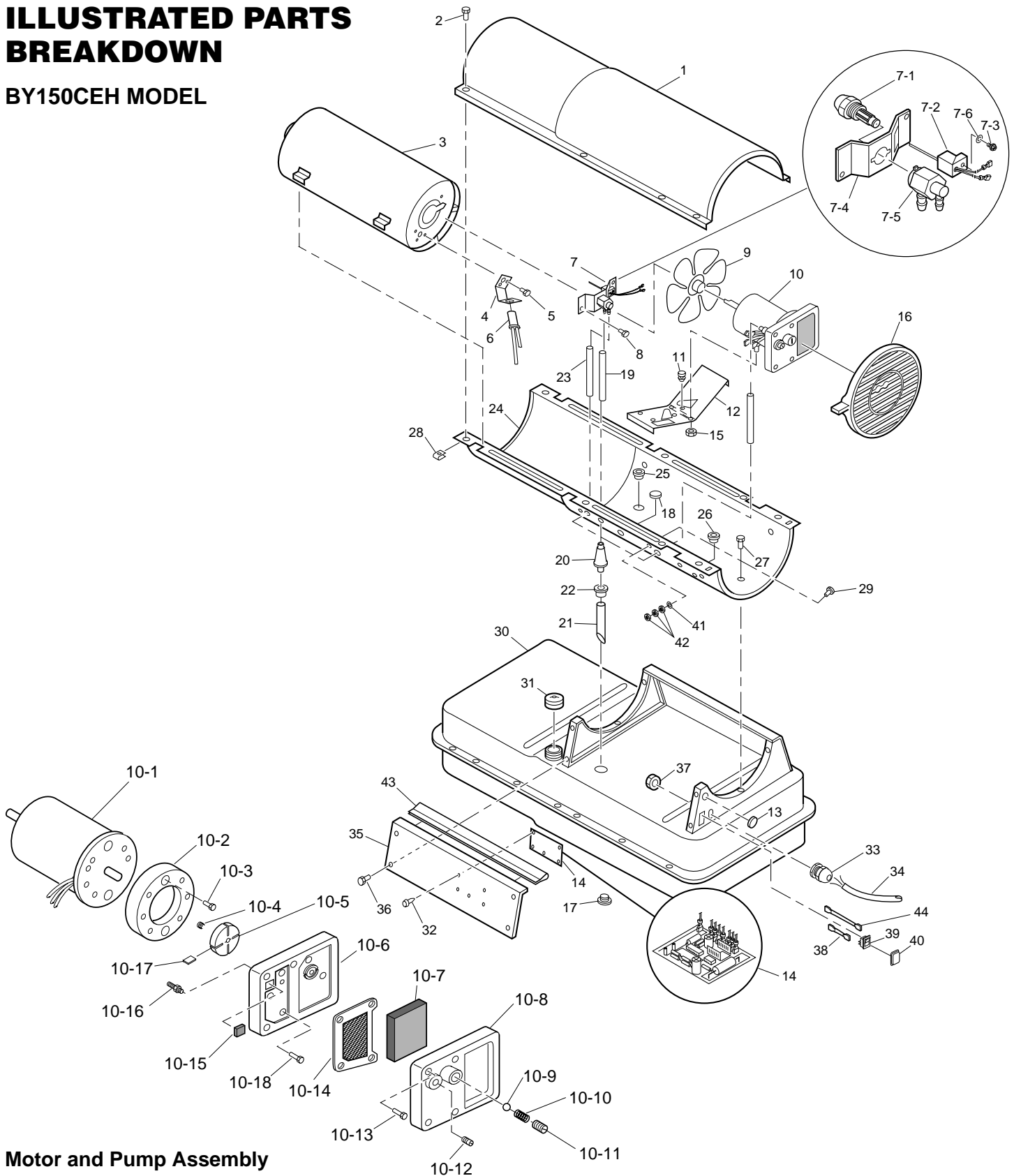

Motor and Pump Assembly

PARTS LIST
BY150CEH MODEL

This list contains replaceable parts used in your heater. When ordering parts, be sure to provide the correct model and serial numbers (from the model plate), then the part number and description of the desired part.

KEY NO.	PART NUMBER	DESCRIPTION	QTY.	KEY NO.	PART NUMBER	DESCRIPTION	QTY.
1	098511-257	Upper Shell	1	15	NTC-4C	Hex Lock Nut, 1/4-20	2
2	102432-01	Screw/Lockwasher, 1/2"	8	16	M51114-01	Fan Guard	1
3	098512-66	Combustion Chamber	1	17	M27417	Drain Plug (Includes "o" Ring)	1
4	103154-05	Photocell Bracket	1	18	099213-01	Button Plug	1
5	M10908-2	Screw, #6-32 x 3/8"	2	19	M51345-04	Fuel Line	1
6	M16656-24	Photocell Assembly	1	20	107961-01	Fuel Filter	1
7	**	Burner Strap Assembly	1	21	M51151-02	Fuel Line Tube	1
7-1	100735-24	Nozzle Assembly	1	22	M10990-3	Rubber Bushing	1
7-2	102548-05	Ignitor Kit	1	23	M50814-03	Airline	1
7-3	M10908-75	Screw, #6-32 x 7/8"	1	24	098511-236	Lower Shell	1
7-4	102336-01	Nozzle Adapter Bracket	1	25	M50104-03	Bushing	1
7-5	104054-01	Nozzle Adapter	1	26	M50104-01	Bushing	1
7-6	103347-01	Belleville Washer	1	27	102431-01	Screw/Lockwasher, 1/2"	6
8	102431-01	Screw/Lockwasher, 1/2"	2	28	M11271-8	Clip Nut	8
9	102042-01	Fan	1	29	RF3-4B	Screw, #10-32 x 1/2"	1
10	**	Motor and Pump Assembly	1	30	108088-05	Fuel Tank	1
10-1	102001-24	Motor	1	31	097702-01	Fuel Cap (Includes Gasket)	1
10-2	079975-03	Pump Body	1	32	102349-01	P.C. Board Support	5
10-3	FHPF3-6C	Screw, #10-32 x 3/4"	2	33	M50400	Strain Relief Bushing	1
10-4	M22009	Rotor Insert	1	34	098872-04	Power Cord	1
10-5	M22456-2	Pump Rotor	1	35	M51077-15	Side Cover	1
10-6	M50545	Pump End Cover	1	36	102431-01	Screw/Lockwasher, 1/2"	4
10-7	M12179	Intake Filter	1	37	102861-01	Nylon Locknut	1
10-8	M16545	Filter End Cover	1	38	079010-39	Wire Assembly (Brown/White)	1
10-9	M8940	Steel Ball, 1/4" Diameter	1	39	105793-01	ON/OFF Switch	1
10-10	M10993-1	Relief Spring	1	40	079919-01	Switch Cover	1
10-11	M27694	Adjusting Screw	1	41	WLE-3	Lockwasher, #10	1
10-12	M22997	Plug	1	42	NPF-3B	Nut, #10-32	3
10-13	M12461-31	Screw, #10-32 x 1"	4	43	097468-01	Edge Liner	1
10-14	M12244-1	Output Filter	1	44	079010-40	Wire Assembly (White)	1
10-15	M11637	Lint Filter	1	PARTS AVAILABLE - NOT SHOWN			
10-16	M50820-02	Barb Fitting	1		HA2210	Filler Neck Screen	1
10-17	M8643-2	Blade	4		103814-01	Wire Tie	1
10-18	M12461-32	Screw, #10-32 x 1 1/8"	6		097650-01	Tradename Decal	2
11	M50631	Rubber Bumper	2		106013-04	Decal Package	1
12	101206-01	Motor Mounting Bracket	1		105880-01	Ignition Control Assembly Fuse	1
13	101695-01	Button Plug	1				
14	104068-04	Ignition Control Assembly	1				

** Not available as an assembly; order parts separately

WHEELS AND HANDLES

BY100CEH AND BY150CEH MODELS

KEY NO.	PART NUMBER	PART DESCRIPTION	BY100CEH QTY.	BY150CEH QTY.
1	HA2203	Handles	2	—
	HA2204	Handles	—	2
2	M12345-33	Screw, #10-24 x 1 3/4"	8	8
3	M12342-3	Wheel Support Frame	1	—
	M12831-3	Wheel Support Frame	—	1
4	NTC-3C	Hex Nut, #10-24	8	8
5	107426-01	Wheel (2)	1	1
6	M28526	Cap Nut	2	2
7	M51015-01	Axle	1	—
	M16801-2	Axle	—	1

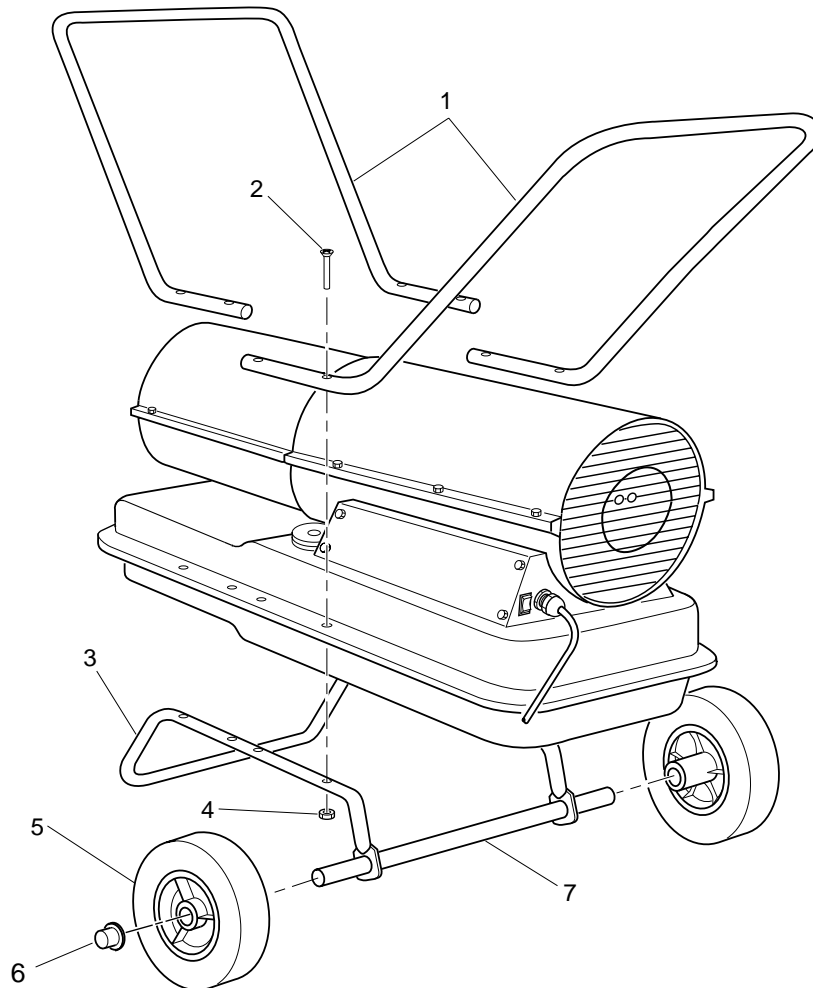

EC CONFORMITY DECLARATION

EC CONFORMITY DECLARATION

SGB YOUNGMAN
Stanestreet, Slingfold, Horsham
West Sussex Rh13 7RD
United Kingdom (UK)

Manufacturer:
DESA International, Inc.
2701 Industrial Drive
Bowling Green, KY 42101 U.S.A.

Kerosene Portable Forced Air Heaters
Model Numbers: BY35CEH, BY70CEH, BY100CEH, BY150CEH

It is declared that these models conform to the Machinery Directive 98/37/EC, including 91/368/EEC and the Low Voltage Directive 73/23/EEC. It is further declared that these models conform to the EMC Directive 89/336/EEC, amended by 92/31/EEC and including EN50081-1 and EN50082-1.

We declare that the models noted are in conformity.

<u>Company</u>	DESA International, Inc.
<u>Name</u>	Keith Teakell
<u>Title</u>	Vice President, Heating Products Engineering

06/13/2001 — Bowling Green, KY

Date and Place



Signature

WARRANTY AND REPAIR SERVICE

CERTIFICATE OF GENERAL EQUIPMENT - LIMITED 1 YEAR WARRANTY

SGB YOUNGMAN warrants new Products sold by it to be free from defects in material or workmanship for a period of one year after date of delivery to the first user and subject to the following conditions:

SGB YOUNGMAN's obligation and liability under this Warranty is expressly limited to repairing or replacing at SGB YOUNGMAN's option, any parts which appear to SGB YOUNGMAN upon inspection to have been defective in material or workmanship when shipped from the factory. Such parts shall be provided at no cost to the user, at the business establishment of any factory authorized service center or the factory during regular working hours. The Warranty shall not apply to component parts or accessories of Products not manufactured by SGB YOUNGMAN and which carry the warranty of the manufacturer thereof, or to normal maintenance (such as pressure adjustments) or to normal maintenance parts (such as filters and spark plugs). Replacement or repair parts installed in the Product covered by this Warranty are warranted only for the remainder of this Warranty as if such parts were original components of said Product. SGB YOUNGMAN MAKES NO OTHER EXPRESS WARRANTY. TO THE EXTENT PERMITTED BY LAW SGB YOUNGMAN MAKES NO IMPLIED WARRANTY AND MAKES NO WARRANTY OF MERCHANTABILITY OR FITNESS FOR ANY PARTICULAR PURPOSE. IN ANY

EVENT IMPLIED WARRANTIES INCLUDING THOSE OF MERCHANTABILITY AND FITNESS FOR A PARTICULAR PURPOSE ARE LIMITED TO THE DURATION OF THIS EXPRESS WARRANTY.

Any transportation charges, costs of installation, duty, taxes or any other charges whatsoever must be borne by the user. SGB YOUNGMAN's obligation under this limited Warranty shall not include any liability for direct, indirect, incidental, or consequential damage or delay. If requested by SGB YOUNGMAN, Products or parts for which a warranty claim is made are to be returned transportation prepaid by user to SGB YOUNGMAN. Any improper use, including operation after discovery of defective or worn parts, operation beyond capacity, substitution of parts not approved by SGB YOUNGMAN, or any alteration or repair by others in such manner as in SGB YOUNGMAN's judgement affects the Product materially and adversely, shall void this Warranty.

NO EMPLOYEE OR REPRESENTATIVE IS AUTHORIZED TO CHANGE THIS WARRANTY IN ANY WAY OR GRANT ANY OTHER WARRANTY UNLESS SUCH CHANGE IS MADE IN WRITING AND SIGNED BY AN OFFICER OF SGB YOUNGMAN AT ITS HOME OFFICE.

WARRANTY SERVICE

Always specify model and serial numbers when communicating with the factory.

We reserve the right to amend these specifications at any time without notice. The only Warranty applicable is our standard written Warranty. We make no other Warranty, expressed or implied.

SGB YOUNGMAN
Stanestreet, Slingfold, Horsham
West Sussex Rh13 7RD
United Kingdom (UK)

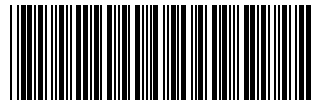

105522 01

NOT A UPC

105522-01
Rev. D
06/01