



ELECTRONIC OVEN

USE AND INSTRUCTION MANUAL

MODD. EKF 523 E UD

rev. 0

TECNOEKA S.r.l.

Via Marco Polo, n.11 - 35010 Borgoricco (Padova) Italy

Tel. +39.049.9300344 – +39.049.5791479 Fax +39.049.5794387

www.tecnoeka.com E-mail: info@tecnoeka.com

X:\Sgq\PRODOTTI\Fam. 1 - FORNI\FORNO ELETTRICO\Eka\MANUALI D'USO - Forno Elettrico 40 60 90 -
LEka\Lingua Inglese\NUOVA GAMMA EF\Instruction manual EKF 523 E UD - GB - rev. 0.doc



TECNOEKA SRL
 VIA MARCO POLO, 11 - 35010 BORGORICCO - PADOVA - ITALY
 TEL. +39 049 5791479 +39 049 9300344 - FAX +39 049 5794387
 E-MAIL: INFO@TECNOEKA.COM - WWW.TECNOEKA.COM - WWW.TECNOEKA.RU
 COD. FISC. - P.IVA 00747580280 - REA N° 133205 - CAP. SOC. EURO 119.000,00 I.V.



CE DECLARATION OF CONFORMITY

Annexed document II A, of directive 2006/42/EC

Manufacturer's name	TECNOEKA Srl
Manufacturer's address	Via Marco Polo, 11 - 35010 Borgoricco (PD)
Manager's name of technical file	Minotto Lorenzo
Manager's address of technical file	Via Marco Polo, 11 - 35010 Borgoricco (PD)
Type of product	Electronic oven
Purpose of the product	Cooking food
Model	EKF 523 E UD

TECNOEKA Srl declares that the mentioned above products meet the following safety regulations:

- Low voltage directive 2006/95/CE
- Electromagnetic compatibility Directive 2004/108/CE.

TECNOEKA Srl declares that the mentioned above products meet the following harmonised standards:

- CEI EN 60335-1 ; CEI EN 60335-2-42
- CEI EN 55014-1 ; CEI EN 55014-2 ; CEI EN 61000-3-2 ; CEI EN 61000-3-3 ; CEI EN 61000-4-2 ;
- CEI EN 61000-4-4 ; CEI EN 61000-4-5 ; CEI EN 61000-4-6 ; CEI EN 61000-4-11 ; CEI EN 62233

TECNOEKA Srl declares that the mentioned above products meet the following directives:

- Machine Directive 2006/42/CE;
- Directive on the general safety of products 2001/95/CE;
- Directive on the restriction in the use of dangerous substances in electrical and electronic appliances 2011/65/CE ;
- Directive on waste from electrical and electronic appliances 2002/96/CE (RAEE).

TECNOEKA Srl declares that the mentioned above products meet the CE 1907/2006 (REACH) Regulation

Borgoricco, 13/03/2014.

 Signature of a Representative of the Board of directors
 (CRISTINA LORA)

Index

1 General information

- 1.1 Technical specifications

2 Instructions for the installer

3 User instructions

- 3.1 General information
 - 3.1.1 Residual risks
- 3.2 Operating instructions
 - 3.2.1 Control panel
 - 3.2.2 Programming cooking time
 - 3.2.3 Programming cooking temperature
 - 3.2.4 Programming cooking climate
 - 3.2.5 Selecting cooking stage
 - 3.2.6 Selecting cooking temperature
 - 3.2.7 Selecting cooking program number
 - 3.2.8 Motors at ½ speed function
 - 3.2.9 Stop motors function
 - 3.2.10 Pre-heating function
 - 3.2.11 Storing programs
 - 3.2.12 Start/stop push button
 - 3.2.13 On/off push button
 - 3.2.14 Light push button
 - 3.2.15 Cool cooking chamber push button
 - 3.2.16 Self clean push button
 - 3.2.17 Clock + 1 push button
 - 3.2.18 Enter or change current time
 - 3.2.19 Start clock push button
 - 3.2.20 Programmed ignition
- 3.3 Magnetic door sensor
- 3.4 First ignition
- 3.5 Cooking techniques
 - 3.5.1 Steam cooking
 - 3.5.2 Convection cooking
 - 3.5.3 Convection + steam cooking
- 3.6 Other cooking techniques
 - 3.6.1 Core temperature cooking technique
 - 3.6.2 Cooking with "ΔT" (Delta-T) function

- 3.7 Operating methods
 - 3.7.1 Manual cooking
 - 3.7.2 Programmed cooking
 - 3.8 Black-out
 - 3.9 Communications with PC
-

4 Cleaning

- 4.1 General information
 - 4.2 Cleaning the cooking chamber
 - 4.3 Cleaning the fans
 - 4.4 Cleaning the door seal
 - 4.5 Cleaning the door
 - 4.6 Cleaning the external casing
 - 4.7 Periods without use
-

5 Maintenance

- 5.1 General information
 - 5.2 Changing the lighting lamp in the cooking chamber
 - 5.3 Changing the door seal
 - 5.4 Resetting the thermal breaker safety device
 - 5.5 Possible faults
 - 5.6 Wiring layout
-

6 Technical service

7 Informations to the consumers

8 The Warranty

1. General information

This information has been prepared for your safety and that of others and we strongly advise reading it carefully before installing and using the oven.

This instruction handbook must be kept together with the oven for future use. If the handbook is mislaid please ask for a copy directly from the manufacturer.

1. If, on receipt of the goods, the **packaging** is damaged, write the following on the delivery note: **"I REVERSE THE RIGHT TO CONTROL THE GOODS"**, specify the damage and get the driver to sign in acceptance; send a claim in writing to the seller within 4 calendar days from the date of receipt. No claim shall be accepted after such period.
2. The oven has been exclusively designed for cooking and heating foodstuffs, any other use is improper.
3. This oven has been designed for professional use and must only be used by qualified trained persons. The oven must never be left unattended when it is operating.
4. In the case of faults or poor operations, turn the oven off, close the water supply valve, unplug from the power mains and contact the authorized Service Centre.
5. All the installation and start-up operations must only be carried out by a technically qualified installer, conforming to the manufacturer's instructions in the full respect of national standards in force.
6. For the periodic maintenance and repair work, contact your nearest Service Centre and ensure only original spare parts are used. Failure to observe this instruction automatically involves losing all rights to the guarantee.

N.B.: Improper and incorrect use and failure to observe the installation instructions releases the manufacturer from any type of liability. In this sense, the instructions given in the paragraph "POSITIONING" must be strictly followed.

1.1 Technical specifications

Dimensions of appliance LxDxH (mm)	610x730x660
Weight (Kg)	44
Convection heating element (kW)	3
Max. absorbed power (kW)	3,2
Power supply voltage (V)	230V~ (50Hz)
Power cable diameter	3x1,5 mm ²
Type of cable	H07RN-F
Connecting electric cable	Tipo Y
Class	I
Degree of protection against humidity	IPX3
Water pressure (kPa)	100-200

The noise level of the appliance when operating is less than 70 dB (A).

2. Instructions for the installer

The following instructions are aimed at the qualified installer, to ensure that he carries out the installation, adjustment and maintenance operations as correctly as possible and according to current legal regulations. Any operation must be performed with electrical power cut to the appliance.

Before using the appliance, carefully remove the special adhesive film protecting the parts in stainless steel. Do not leave any glue residues on the surfaces. If necessary, remove them at once, with an appropriate solvent.

Fitting the feet - The feet are inside the appliance and must be secured on the four threaded holes on the base. If necessary, the height of the feet can be adjusted by screwing or unscrewing.

Positioning - Position the appliance perfectly horizontally on a table or similar support (the table or support must be at least 85 cm above the floor). Position it at a distance of not less than 10 cm from the side and rear walls, to enable natural ventilating air to circulate freely around it. The appliance is ventilated through specific openings on the metal walls of the outer housing, and ensures efficiency and long-life. For this reason it is strictly forbidden to obstruct these ventilation openings, even partially or for short periods. **Failure to observe this specific prohibition releases the manufacturer of the appliance from all responsibility and immediately voids any guarantee rights for the said appliance**, because its constructive conformity has been voluntarily compromised. Furthermore, the appliance is not suitable for embedding and for grouped positioning with other identical appliances.

Electrical connection - The appliance must be connected to the electrical mains according to current legal regulations. Before making the connection, make sure of the following:

- the voltage and frequency values of the power supply system match the values on the "technical data" plate affixed on the appliance;
- the limiting valve and the system are able to support the appliance's load (see the "technical data" plate);
- **the power supply system has an adequate earth connection according to current legal regulations;**
- a monopolar switch with minimum between-contacts aperture of the overvoltage category III (4000 V), sized to the load and conforming to current legal regulations, is fitted between the appliance and the mains in the direct connection to the mains;
- the monopolar switch used for connection is easy to reach when the appliance is installed;
- **the yellow/green earth wire is not interrupted by the switch;**
- the power supply, when the appliance is operating, must not deviate from the rated voltage value by $\pm 10\%$;
- make sure that after inserting the power supply cord into the terminal block it does not come into contact with any of the cooking range's hot parts;
- **if the supply cable is damaged then it must be replaced by the manufacturer or by your technical support or by a qualified person to avoid any risk.**

Connection to water mains - The oven must be supplied with softened drinking water with a hardness value of 0.5 to 3°F (it is obligatory to use water softener to reduce the formation of scaling inside the cooking chamber). The water pressure must be in the range of 100 to 200 kPa (1.0 – 2.0 bar). If the water pressure exceeds 2.0 bar, install a pressure reducer device upstream. If the pressure is below 1.0 bar, use a pressure pump to increase the level.

Water drainage

A drain pipe comes out from the rear of the appliance, to drain the oven cavity. This pipe must be connected up to a pipe made to resist steam temperatures (90°C-100°C) with an internal diameter of 16 mm (DN 16). To prevent choking, it is best to use a rigid pipe and make sure there are no "elbow" bends anywhere along the drain line.

Furthermore, the drain line must slope down (minimum slope 5%) along its full length (the length in question is from the appliance's drain pipe to the drain point and must not exceed 2 metres). The drain line must run into an open floor drain (Fig.1). In addition, there must be a free air gap of at least 25 mm (distance between the drain line coming from the appliance and the funnel on the drain standpipe). Whatever the case, in order to comply with current hygiene standards, the line connected to the appliance's drain pipe must not come into direct contact with the drain point. It is advisable to include a suitable trap in the line connecting the appliance's drain outlet to the grey water waste system, thus stopping the steam coming back out of the drain.

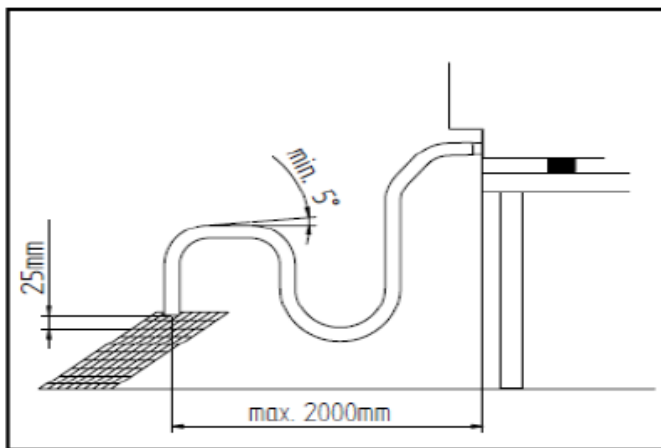

FIG. 1

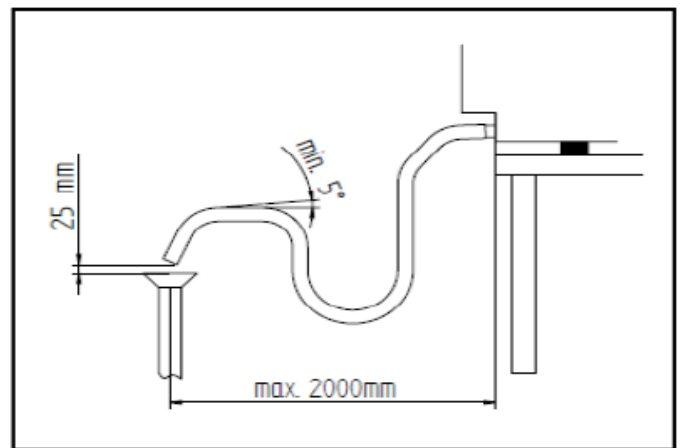

FIG. 2

Connection to water tank - (for ovens predisposed to water pump)

To replace electrovalve with water pump (in ovens with optional predisposition to pump), follow the steps below listed (image 3):

- 1) Remove back cover from oven.
- 2) Disconnect wiring cables from electrovalve.
- 3) Disconnect water tube (3) from electrovalve, pressing e keeping pressed the edge of black linking (quick insertion).
- 4) Remove the electrovalve unscrewing the screw that fix it to oven's frame.
- 5) Fix the pump (1) to the frame with the appropriate support (2) and the two screws (4) included.
- 6) Connect the cables previously disconnected from electrovalve to pump.
- 7) Connect the tube previously disconnected from electrovalve to pump's linking.

- 8) Connect the tube (6) with filter and ballast (included in "Pump kit") to pump's apron (7).
- 9) Replace back cover.

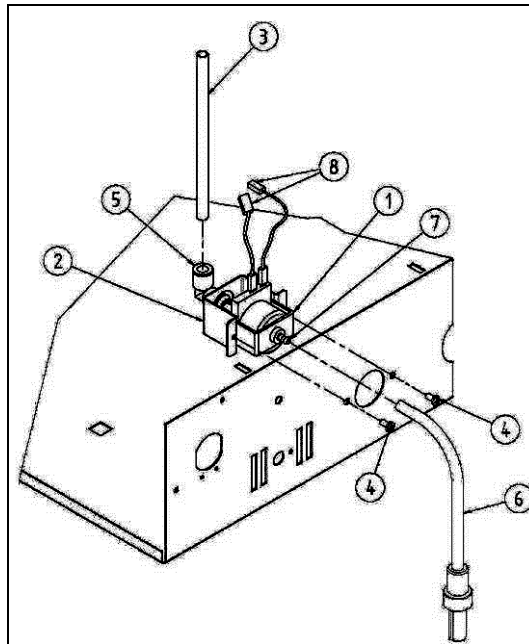

Fig.3

Warning:

To avoid limestone buildup into the cooking chamber, we suggest to fill the water tank with decalcified water.

Check water level in the tank before activating the pump and during its functioning. If pump works without water in the tank, what occurs is abnormal noise at first and then its breakage.

Connection of power cable

The terminal board is on the rear panel of the appliance. Open the terminal board cover by obtaining leverage with a screwdriver on the two side fins. Loosen the cable gripper screw and allow the cable to pass through it. Arrange the conductors so that the earth conductor is the last to detach from its terminal if the cable goes into a state of faulty traction. Connect the **phase** conductor to the terminal marked with the letter "L", the **neutral** conductor to the terminal marked with the letter "N" and the **earth** conductor to the terminal marked with the symbol \perp . Tighten the ring-nut of the cable gripper and close the terminal board cover. The appliance must be connected to an **equipotential system** whose efficiency must first be checked according to current legal regulations. This connection must be made between different appliances by using the appropriate terminal marked with the symbol ∇ . The equipotential conductor must have a minimum diameter of 2,5mm². The equipotential terminal is at the rear of the appliance.

Safety thermal breaker

The appliance has a manually reset safety thermal breaker. It protects against excessive dangerous over-temperatures which could be accidentally generated inside the appliance. If the device is tripped, it interrupts electrical power to the appliance and thus prevents it from operating.

3. User instructions

3.1 General information

- When using the oven for the first time, we advise you to run it load-free at maximum temperature for about one hour. In this way, any unpleasant smells, due to thermal insulation, and grease residue from assembly are eliminated.
- This appliance must be exclusively used for the purposes for which it was expressly designed, i.e. cooking foods in the oven, any other use is improper.
- The oven can be used for all oven cooking of pastry, bakery and gastronomy products, fresh and frozen, for re-conditioning refrigerated and deep frozen foods, for steam cooking meat, fish and vegetables.
- When placing food in the cooking chamber, allow a space of at least 40 mm between pans to avoid over-obstructing the airflow.
- Do not use pans with edges higher than necessary: the edges act like barriers preventing circulation of hot air.
- Pre-heat the oven before each time it is used to guarantee the best performance.
- For the cooking to be as even as possible, place the food evenly in each pan, considering the size of the pieces, layers or the thickness.
- Do not salt the food when it is in the cooking chamber.
- To check the cooking cycle is proceeding correctly use the internal light in the chamber do not open the door if it is not necessary, to avoid wasting energy and prolonging cooking times.

3.1.1 Residual risks

- After a cooking operation, open the door cautiously, to avoid a violent outflow of heat which could cause burns.
- While the oven is in operation, pay attention to the hot zones (marked on the appliance) of its external surfaces.
- Place the machine on a bench or similar support, at a height of at least 85 cm from the floor.
- The bench or support must be able to support the weight of the machine and house it correctly.
- To prevent incorrect connection of the appliance, the relevant electrical and water connections are marked by identification plates.
- The appliance contains electrical parts and must never be washed with a jet of water or steam.
- The appliance is electrically connected: before attempting any cleaning operation, cut power to the appliance.

3.2 Operating instructions

3.2.1 Control panel

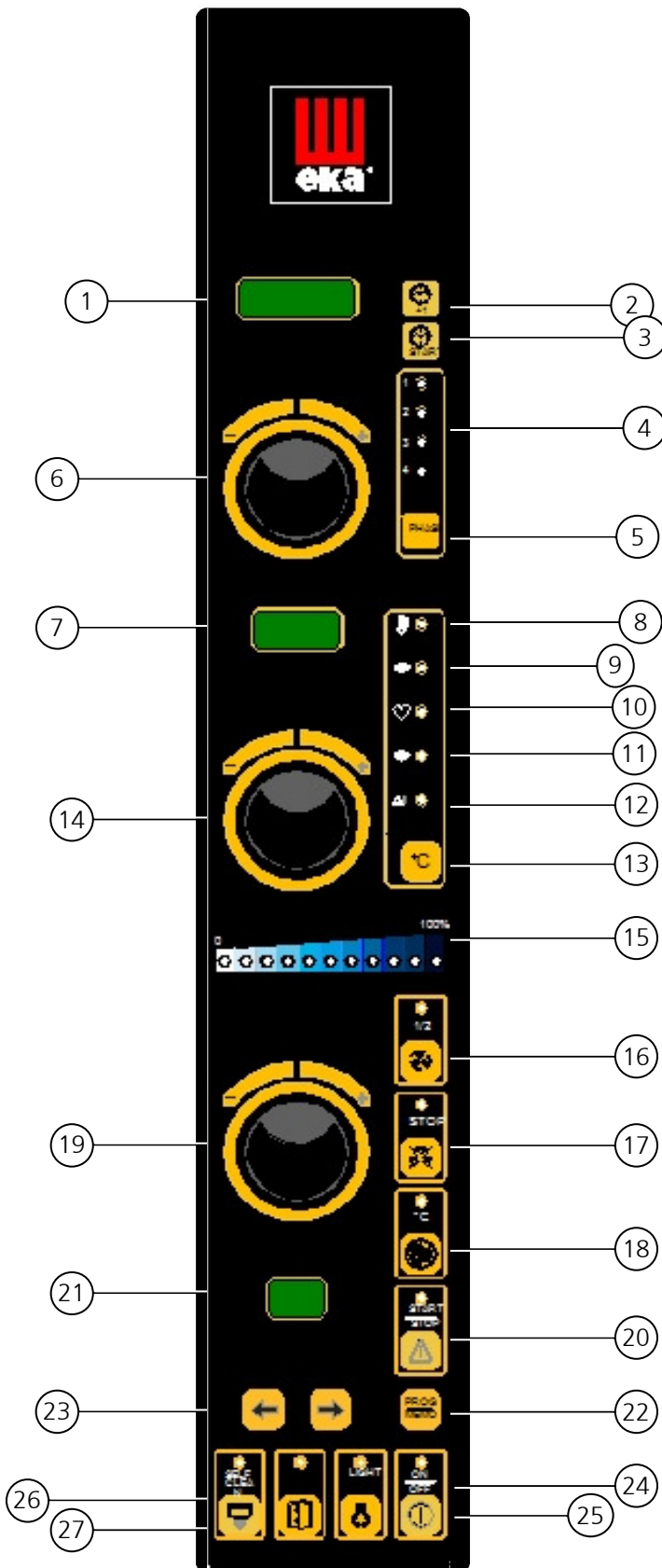

1. Time display
2. "+1" push button and hour/minute display (on the time display)
3. Current time display push button (on the time display)
4. Green signal light for an active stage
5. Phase selection push button
6. Time setting knob ("1")
7. Temperature display
8. Set temperature in cooking chamber
9. Actual temperature in cooking chamber
10. Set temperature for core probe
11. Actual temperature at core probe
12. Set "ΔT" temperature
13. Temperature selection push button (on temperature display)
14. Temperature setting knob ("2")
15. Climate display led bar
16. Motors at 1/2 speed push button
17. Stop motors push button
18. Pre-heating function push button
19. Climate setting knob ("3")
20. Start/stop push button for cooking cycle
21. Display programs
22. Storing programs push button
23. View programs push button (1÷99)
24. On/off push button
25. Cooking chamber light push button
26. Wash boiler push button (NOT ACTIVATED)
27. Cooking chamber cooling push button

3.2.2 Programming cooking time

To set the cooking time (from 1 minute to 4 hours) use the knob no. "1". The set values can be seen on the **time display**.

3.2.3 Programming cooking temperature

To set the cooking temperature (between 50°C and 270 °C in the cooking chamber and between 0°C and 100°C for the "ΔT" and the core probe) use the knob no. "2". The set values can be seen on the **temperature display**.

3.2.4 Programming cooking climate

To set the cooking climate (dry or steam) use knob no. "3". The set value in percentage is shown on the **led bar** formed of: **10 blue leds** (from 10 to 100%) for the **steam** selection (turn the knob in an anti-clockwise direction). The white led shows when the climate function is not activated.

3.2.5 Selecting cooking stage



To select the cooking stage (from 1 to 4) press the push button . When the green led lights up it shows the stage has been selected. **The required cooking parameters (time/temperature/climate) can be set for each selected stage.** The push button can be pressed at any time to check the time for each cooking stage.





When the oven is operating, the remaining cooking time can be seen for all 4 stages on the time display (the flashing led shows which cooking phase is actually in progress).



An "infinite" time can be set in the 1st and 4th stages (turn the knob no. "1" in an anti-clockwise direction): the time display shows the wording "inF" (1st stage) or "HoLd" (4th stage – which is useful for keeping the food hot when it is cooked). The other stages cannot be selected in these cases.

3.2.6 Selecting cooking temperature

To select the cooking temperature (in the cooking chamber / core probe "ΔT") press the push button . When the green led lights up it shows the selected temperature, which can be seen on the **temperature display**.

Temperature in the cooking chamber: When the oven is turned on the temperature in the cooking chamber is automatically selected (led alight on ). To set the required level turn knob no. "2". When the oven is operating, the set temperature (led alight on ) and the current temperature in the cooking chamber (led alight on ) are alternatively displayed.



Core temperature in the food: To set the temperature for cooking inside the food, press the push button  until the led next to the  symbol lights up and then turn knob no. "2". When the oven is working (with the needle probe inside the food) the set temperature (led alight on ) and the current temperature inside the food (led alight on ) are alternatively shown.

ΔT temperature (DELTA-T): To set the temperature for the "ΔT" function, press the push button  until the led lights up next to the ΔT symbol and then turn knob no. "2". When the oven is working (with the needle probe inside the food) the current temperature in the cooking chamber (led alight on ) and the set temperature for "ΔT" (led alight on ΔT) are alternatively shown.

N.B.: *If the cooking chamber temperature and the core temperature for the food are set, the "ΔT" temperature function is automatically deactivated.*

If the core temperature for the food is set and then the "ΔT" temperature, the cooking chamber temperature function is automatically deactivated.

3.2.7 Selecting cooking program number

To select the cooking program number (there are 99 programs in all) press the push button  (from 1 to 99) or the push button  (from 99 to 1). The selected program number is shown on **display programs**. To rapidly view the programs keep the push button pressed.

3.2.8 Motors at 1/2 speed function

To activate this function press the push button . When the green led lights up it confirms the activation. This function remains operative until the push button is pressed a second time. If this function is included in one of the four cooking stages, the passage to the next cooking stage is automatically deactivated. **This function cannot be activated during a programmed cooking cycle.** By halving the speed of the motors (fans), the heating capacity is halved too and therefore the cooking times and the amount to be cooked must be adjusted. (The different noise of the motors is quite normal at reduced speed).

3.2.9 Stop motors function

To activate this function press the push button . When the green led lights up it confirms the activation. This function remains operative until the push button is pressed a second time. If this function is included in one of the cooking stages, the passage to the next cooking stage is automatically deactivated. **This function can be activated and deactivated at any time, even during a programmed cooking cycle.**

When the motors (fans) are stopped, the heating elements and climate regulation are deactivated, therefore if this function is included in a program, it can be used to delay the start of the cooking cycle or as a pause during the cycle (for leavening the product inside the cooking chamber).

3.2.10 Pre-heating function

To activate this function press the push button . When the green led lights up it confirms the activation. **The function is automatically deactivated when the pre-heating temperature is reached**, otherwise, it can be deactivated by pressing the push button during a cooking stage (the oven pre-heating can be cut off at any time).

If this function is activated in a programmed cooking cycle, it is not stored with the other parameters of the program and, therefore, it must be activated each time a new cooking cycle is started: either programmed or manual. **The function adds a temperature delta Δ only to the temperature that was set in the first stage of the cooking cycle**, to compensate any heat loss caused by opening the oven door to introduce the food.

If this stage is activated, when the cooking cycle starts the time display shows the wording "HEAt". As soon as the pre-heating temperature is reached a beeper sounds, which stops only when the oven door is opened for introducing the food (the wording "HEAt" continues flashing). When the door is closed, the programmed cooking cycle starts automatically and the time display shows the set cooking time.

3.2.11 Storing programs

Select the program number you wish to store. Set the parameter sequence: time/temperature and climate for each of the four cooking stages. Press the push button  until the beeper informs you it has been stored. To cancel a stored program, just replace it with a new one with the same number, containing the new parameters for the four cooking stages. The new program must then be stored.

3.2.12 Start/stop push button

Once a programmed cooking cycle has been selected or a manual cycle set, press the push



button to start cooking. The green led lights up and the beeper sounds to confirm the cooking cycle has started. To interrupt the cycle the push button can be pressed at any time.

3.2.13 On/off push button



Press the push button to turn the oven on and off. When the oven is off, the green led is on and vice versa. When the oven is cooking, this push button is disconnected: **to turn the oven off you must first stop the cooking** (pressing the START/STOP push button).

3.2.14 Light push button



Press the push button to light the cooking chamber. When the green led lights up it confirms the light is on. The light turns off automatically after 60 seconds. If the push button is kept pressed until the beeper sounds it confirms that the light will remain on. To turn the light off press the push button again.

3.2.15 Cool cooking chamber push button

To rapidly cool the cooking chamber at the end of a cooking cycle, hold the door open and



press the push button. When the green led lights up it confirms the function is activated. During forced ventilation, the temperature in the cooking chamber is shown moment by moment on the temperature display.



3.2.16 Self clean push button

The function is **not activated** for this model of equipment.

3.2.17 Clock + 1 push button

At the end of the cooking cycle the beeper sounds for 10 seconds and the figure "0000" begins flashing on the display. While the figure is flashing, which lasts for 60 seconds, by pressing the push button  the cooking time can be extended: each time the push button is pressed the time is increased by one minute (the option is deactivated at the end of the cooking cycle with the probe in the core). When the oven is turned OFF the time display shows the current time: to change or enter the time (if it is missing) press the push button.

3.2.18 Enter or change current time



With the oven turned OFF, press the push button  and the two figures relative to the hour begin flashing on the time display. Use the knob "1" to enter the current hour. The day of the week is shown on the temperature display (1= 7 through to 7 = Sunday). Use knob no. "2" to enter the current day. Press the push button  again and the two figures will start flashing on the time display relative to the minutes. Use knob "1" to enter the current minutes. When the push button  is pressed again the time display shows the complete time.

3.2.19 Start clock push button

With the oven turned ON or during the cooking cycle, when the push button  is pressed at any time, the current time can be checked on the time display (the other displays are deactivated).

3.2.20 Programmed ignition

With the oven turned OFF, when the push button  is pressed, the parameters are shown that have been entered for programmed ignition: the time (time display), the day (temperature display) and the cooking program number (program display). To change the parameters press

the push button . The two figures showing the hour begin flashing on the time display: use the knob no. "1" to enter the required ignition hour. The figures showing the day start flashing on the temperature display: use knob no. "2" to enter the required day (from 1 = Monday to 7 = Sunday). The two figures relative to the cooking program start flashing on the program display: use the scroll buttons to enter the required cooking program number. Press the push button  again and the two figures showing the minutes start flashing on the time display: use the knob no. "1" to enter the required minutes. Press the push button 

time is shown on the time display. Press  and the green led starts flashing to confirm that the oven is on stand-by ready for programmed ignition.

To cancel programmed ignition press the push button  again.

3.3 Magnetic door sensor

This device stops the oven and the cooking cycle each time the door is opened.

3.4 First ignition

The oven can be used for the first time only after the chamber has been carefully cleaned with a special detergent for stainless steel. The detergent must not contain acid substances (chloride acid, bleach, etc.) or be abrasive. Alternatively the chamber can be washed with warm soapy water or warm water and a drop of vinegar. Rinse well and dry with a soft cloth.

First ignition (without food inside the oven) serves to eliminate any unpleasant smells (which are quite normal) due to the thermal insulation heating up that covers the cooking chamber and any oil residues from assembly of the metal parts.

After turning the power on (close the unipolar switch fitted upstream from the appliance) and the water (open the cut-off cock), proceed as follows (see the figure of the control panel):

- press the on/off push button;
- set the time (knob "1") at one hour (shown on the time display);
- set a temperature (knob "2") of 270°C for the cooking chamber (shown on the temperature display);
- check the door is closed;
- press the start/stop push button: the cooking chamber starts heating up.

When the time is up, the oven turns off automatically and the beeper sounds for 10 seconds.

3.5 Cooking techniques

There are three different cooking techniques with this oven which can be used singularly, one after the other or combined.

3.5.1 Steam cooking (moist heat)

The climate regulation system which allows dividing the humidity production that should be set at 100% (humidity \ continuous steam) , while the cooking chamber temperature can be set between 105°C and 115°C.

Steam cooking is indicated where a boiled effect is required, and it has the advantage of leaving the nutritional content of the food unchanged (the vitamins and flavour of the food are conserved), the outer appearance (the colour is conserved, no lumps or air bubbles are formed and the surface does not break up) and the weight is conserved, as no liquids are lost from the food during cooking.

3.5.2 Convection cooking (dry heat)

The heating elements heat the dry air inside the cooking chamber. This heated air is evenly distributed by the high speed of the fans. This gives an even temperature throughout the cooking chamber and even cooking even when the oven is full.

This means that different types of food can be cooked on the various shelves (as long as they need the same cooking temperature) without flavours and smells being mixed together.

The cooking chamber temperature can be set between 50°C and 270°C.

Besides evenly browning the food without having to turn it, convection cooking can be used to cook au gratin and is particularly convenient for rapid defreezing, for sterilising preserves and drying mushrooms and fruit.

3.5.3 Convection + humidity cooking (dry heat + moist heat)

This type of cooking exploits the combination of dry and moist heat. They are dosed by the climate regulation system which can divide, in percentage, the production of steam and the production of dry heat (drying the cooking chamber), optimising the cooking climate for each dish.



The cooking chamber temperature can be set between 50°C and 270°C.

The fact of using a hot-moist climate inside the cooking chamber with variable temperature and moisture levels, is the most convenient and efficient way of cooking: cooking times are reduced, the surface of the foods remains soft and does not form a crust, there is little weight loss and the fatty mass is reduced.

The special hot-moist climate at low temperatures is ideal for re-conditioning food.

3.6 Other cooking techniques

3.6.1 Core temperature cooking technique

The temperature can be set inside the core of the food to be cooked, using the special needle core probe that is supplied with the oven. The probe must be pushed into the centre of the food in the thickest part, avoiding the bones. Place the food inside the cooking chamber and pull out the thermal probe lead and close the oven door. The probe plug must be plugged into the special socket (see Fig. 1) at the bottom of the control panel. Press the push button  to select the core cooking temperature (led alight on ) between 0°C and 100°C using knob no. "2", the temperature is shown on the temperature display.

When a cooking cycle is started with a core probe stage included (the time display shows the wording "Prob"), when the set temperature is reached inside the food the cooking cycle passes onto the next stage no matter what time has been set. If the core probe is activated within any of the four stages, with the other three deactivated, the cooking cycle finishes automatically when the set temperature inside the food is reached, no matter what time has been set.



Cooking with the core probe can be graduated over the four stages (for very delicate cooking) and, for each stage, the temperature and the climate inside the cooking chamber can be set besides the temperature inside the food.

As the thermal probe is a needle which can easily be removed or broken, we advise setting the cooking time for the stage that it is used in.

If the probe is connected and operating, the stage finishes when the set temperature is reached; otherwise, if the probe is not connected or is broken, the stage finishes at the set time.

If the probe is not connected or is broken, when the cooking cycle starts the beeper sounds intermittently for 10 seconds, the time display shows the flashing message "Prob" and the previously set temperature disappears from the temperature display (- - -).

The core temperature of the food can also be measured (when no temperature has been set): it is sufficient to slide the needle probe into the food.

In this case, when the cooking cycle has been started, when the push button  is pressed the temperature is selected automatically (shown on the temperature display) that is measured by the probe (led alight next to .

Warning: Before removing the food from the oven after cooking with the core needle probe. Carefully remove the hot probe from the cooked food, taking care not to leave it hanging out of the cooking chamber as it could cause burns. We advise leaving it to cool down before using it again – to avoid damaging pricks in the food. To prevent any irreparable damage to the thermal piercing probe (core probe) do not use it in high temperature cooking ABOVE 230°C, and ensure that the probe lead is not touching any hot metal surfaces inside the oven.

3.6.2 Cooking with "ΔT" (DELTA-T) function

This function allows keeping the difference (ΔT) between the temperature inside the food (measured by the needle probe) and the temperature in the cooking chamber constant. This means that the temperature in the cooking chamber is the sum of the temperature inside the food and a fixed "ΔT" temperature that is set by the user (see the graph).

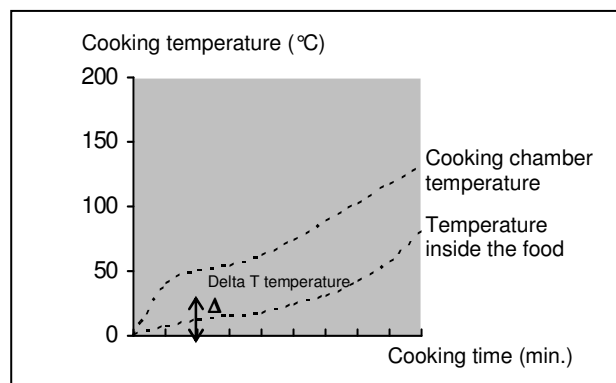

The Delta-T temperature is the difference between the temperature inside the food and the temperature in the cooking chamber

In practical terms, there is a gradual increase of the temperature in the cooking chamber, with a constant difference with respect to the temperature inside the food which, thanks to this constant difference, is cooked slowly and gently (in meat the proteins are protected, as no surface tension is caused by the rapid formation of the crust).

After selecting the temperature inside the food (core temperature) and setting the level (knob "2") press the push button  again to select the "ΔT" function (the led next to the ΔT symbol lights up) and to set the temperature (knob "2") (on the basis of our experience this temperature should be between 30°C and 70°C).

When the "ΔT" function is used for cooking, the method for using the needle probe is the same as that described in paragraph 3.6.1.

3.7 Operating methods



3.7.1 Manual cooking

After turning the oven ON (green led off), set the various cooking parameters.

Set the cooking time (shown on the time display) using the knob no. "1":

- "inF" (stages excluded /stage led off)
- from 1 minute to 4 hours per stage ("inF" excluded / stage leds alight)

Set the cooking temperature (shown on the temperature display) for one or more stages, using knob no. "2":

- cooking chamber (from 50°C to 270°C / led alight on )
- core probe (from 0°C to 100°C / led alight on )
- ΔT / DELTA-T (from 0°C to 100°C/ led alight on ΔT)

Set the cooking climate (shown on the led bar) for one or more stages, using knob no. "3":

- neutral (white led alight)

- only steam (all 10 blue leds alight /100%)
- variable steam (blue leds 1 to 9 alight /from 10 to 90)

Set the pre-heating function (optional) pressing the push button .

Set the motors at 1/2 speed function (optional) for one or more stages, pressing the push button



. Press the push button  to start the cooking cycle.

Remember:



1. If the cooking cycle is not controlled by the core probe and has been divided in one or more timed stages, the oven turns off automatically when the set time for the single stage or all the different stages together is over. If an "inF" (infinite) time has been set,

the oven continues until the operator turns it off manually pressing the push button .

2. If the cooking cycle is controlled by the core probe and has been divided in one or more stages, timed if required, when the temperature set on the probe is reached it passes onto the next stage; if it has been set for a single stage, timed if required, or for an "inF" time, the cycle finishes and the oven turns off automatically, no matter what time was set for the stage.

3.7.2 Programmed cooking



When the cooking programs have already been stored (a cooking cycle corresponds to each program number for a specific type of food) it is very easy to use them.

Turn the oven ON (green light off) select the stored program number (shown on the program display) using the push buttons  or .



Press the push button  to start the cooking cycle.

At the end of the cooking cycle the oven turns off automatically and the beeper sounds for 10 seconds.

Remember: Before beginning the cooking cycle, the parameters can be checked that have been set for the four stages (press the push button ) and they can be changed if wished. For the changed parameters to become operative, they must be stored (press the push button  until the confirming beep is heard).

3.8 Black-out

When the power supply returns after a black-out, the oven will continue working counting the remaining time for the cooking cycle after the interruption.

3.9 Communications with PC

At the bottom of the control panel (seen from below) there is an inlet (remove the rubber protection) for a serial gate for interactive communications with a PC.

If this gate is connected to a PC with **wineka software** (optional), up to 99 preset cooking programs can be transmitted to the oven memory for all the operating parameters; likewise, the cooking programs that are already stored in the oven memory can be acquired by the PC. Certain operational parameters for the oven can also be changed.

4. Cleaning

4.1 General information

Before beginning any sort of cleaning work on the appliance, turn the power supply off (at the magnetothermal safety switch) and the water supply (by closing the cut-off cock) and then let the oven cool down completely.

The appliance must be cleaned frequently, preferably daily, to guarantee best operations and long life. This is an electric appliance therefore for obvious reasons water should not be used in excess for cleaning. However, **it is absolutely forbidden to wash the appliance with water jets, especially if they are pointed towards the aeration vents on the metal surface of the outside casing** (this could cause dangerous infiltrations that would damage the electric parts).

If grease remover detergents are used to clean the stainless steel, ensure they do not contain corrosive acids (no sort of chlorine, even if it is diluted) or abrasive products. Follow the indications given on the product and the warnings about its use, wearing rubber gloves during cleaning.

Do not use iron pads, steel wool or scrapers as they would ruin the surfaces.

Do not leave food on the steel surfaces for a long time that contain acid substances (lemon juice, vinegar, salt, etc.) as they could cause corrosion.

4.2 Cleaning the cooking chamber

For hygienic reasons, it is good practice to clean the cooking chamber at the end of each cooking cycle, otherwise it should be cleaned at least once at the end of each day's use.

For easier cleaning, remove the side grills by unscrewing the 4 fixing screws (hold the reeded nut between your thumb and forefinger and turn it in an anti-clockwise direction) remove the drainage plug on the bottom and proceed as follows:

- spray a special degreasing product for stainless steel on the external walls, on the fan casing (do not spray it through the fan grids) and on the glass inside the door;
- leave the product to work for approximately 20 minutes with the door closed;
- turn the oven on to 70-80°C;
- run a cycle with maximum steam (100%) for around 15 minutes;
- when the cycle is complete turn the oven off, leave the cooking chamber to cool down and rinse well;
- Dry with a soft cloth or run a heating cycle, with the temperature at 150-160°C for about 10 minutes (the cycle can be repeated if necessary).

The side grills and drainage plug must be cleaned separately and then replaced.

When cleaning is terminated, leave the oven door slightly ajar.

4.3 Cleaning the fans

The fans must be periodically cleaned with specific anti-limescale products. All the parts must be carefully cleaned, removing all limescale deposits.

To have access to the fans remove the fan casing after removing the screws that fix it to the cooking chamber. When cleaning is complete, replace the casing and screws.

4.4 Cleaning the door seal

For hygiene and good operations, it is good practice to clean the door seal at the end of each day's work. It should be carefully washed with warm soapy water, rinsed and dried with a soft cloth. Any incrustations or food deposits must be carefully removed, without using sharp metal tools which could irreparably damage the seal.

4.5 Cleaning the door

The glass on the door inside the cooking chamber can be cleaned with the same degreaser as used for cleaning the chamber or a normal glass cleaning product can be used (non toxic). Normal glass cleaning products can also be used to clean the glass on the outside of the door, or simply warm soapy water, rinse and then dry the glass well with a soft cloth.

4.6 Cleaning the external casing

The external steel surfaces should be cleaned with a cloth soaked in warm soapy water or with a drop of vinegar added, they should be rinsed well and dried with a soft cloth.

If you use specific cleaning products, they must correspond to the requirements for cleaning given in the paragraph "General information" (paragraph 4.1).

You should also remember that the table the appliance stands on or the surrounding floor should not be cleaned using corrosive acid products (for example muriatic acid), as the fumes that are given off could attack and damage the external steel casing.

4.7 Periods without use

If the appliance is not used for a long time, it is good practice to unplug it from the mains (at the magnetothermal safety switch upstream from the appliance) and to turn off the water with the cut-of cock on the main supply line. It should be carefully cleaned inside the cooking chamber and outside, taking special care to remove any salt deposits which would cause corrosion to the steel surfaces.

We also advise protecting the appliance with an oily base spray (e.g. Vaseline oil), which forms an effective protective film on the surface of the steel.

A suitable covering would also protect the appliance from the dust.

5. Maintenance

5.1 General information

A periodic control (at least once a year) of the appliance aids to guarantee long life and correct operations.

Any sort of maintenance work on the appliance must be done exclusively by technically qualified operators who have been trained in the maintenance work on this appliance.

Before beginning any sort of maintenance work on the appliance, turn the power supply off (at the magnetothermal safety switch upstream from the appliance) and let it cool down.

Access is gained to the inside components that could require maintenance work by removing the left side of the appliance.

5.2 Changing the lighting lamp in the cooking chamber

Electrically switch off the appliance; unscrew the protective glass cap with the corresponding rings for airproofing; unscrew the lamp and replace it with another lamp suitable for high temperatures (300°C), with the following characteristics:

- Voltage 230/240 V
- Power 15 W
- Fitting E 14

Refit the glass cap with the corresponding rings for airproofing and power up the appliance.

5.3 Changing the door seal

The door seal has a rigid profile with fixing tabs. The profile must be fitted into the guide on the face of the cooking chamber.

To change the seal, remove the old one from the guide by pulling hard at the four corners.

Clean any dirt from the guide and introduce the new seal (to make this operation easier, we advise dampening the seal profile with soapy water).

5.4 Resetting the thermal breaker safety device

This device is reached by removing the left side of the appliance and can be reset by pressing the key right down (which is marked by a special adhesive label), which is inside the electric components compartment.

5.5 Possible faults

Type of fault	Cause	Corrective action
Control panel completely off (the oven does not work)	- Incorrect electric connections to the mains	- Check the mains connection
	- No mains voltage	- Restore mains voltage
	- Thermal break safety device tripped	- Reset the thermal break safety device
	- Electronic card protection fuse (power) burnt	- Contact a qualified technician
Cooking cycle set and START push button pressed: the oven does not work	- Door open or ajar	- Close the door
	- Damaged magnetic sensor	- Contact a qualified technician to repair the sensor
Humidity Cycle/ steam activated: no humidity/steam is produced in the cooking chamber	- Incorrect connection to water mains	- Check the connection to water mains
	- Cut-off cock closed	- Check the cut-off cock
	- Blocked water inlet filter	- Clean the filter
	- Damaged water inlet solenoid	- Contact a qualified technician to repair the solenoid
Door closed: steam comes out of the seal	- Seal not fitted correctly	- Check the seal fitting
	- Damaged seal	- Contact a qualified technician to repair the seal
	- Handle prong loosened	- Contact a qualified technician to repair the prong
The oven does not cook evenly	- One of the motors is blocked or turns slowly	- Contact a qualified technician to repair the motor
	- The motors do not go into reverse	- Contact a qualified technician to repair the motor
	- Heating element not powered or is damaged	- Contact a qualified technician to repair the element
Lighting lamp in the cooking chamber does not work	- Damaged lamp	- Change the lamp
	- Damaged lamp feeder	- Contact a qualified technician to repair the feeder
The wording "Er1" appears on the temperature display	- Break in the connection between the cooking chamber probe – electronic (power) card	- Check the connection to the electronic card
	- Damaged cooking chamber probe	- Contact a qualified technician to repair the probe
"Er3" is displayed on the temperature display and an alarm is activated that can be silenced by pressing the  button. Cooking can continue but it is necessary to remove the cause of the fault causing the electronic board to overheat.	- Cooling motor fan damaged	- Contact a qualified engineer to repair it
	- Aeration openings present in the metal walls blocked	- Unblock the openings
	- Heat sources too near the oven	- Eliminate the heat sources
"Hot" flashes on the temperature display. The oven stops automatically and the alarm is activated for 30 seconds. The oven can be restarted only when the electronic board has completely cooled down	- Cooling motor fan damaged	- Contact a qualified engineer to repair it
	- Aeration openings present in the metal walls blocked	- Unblock the openings
	- Heat sources too near the oven	- Eliminate the heat sources
Core temperature activated and probe connected to the control panel: the message " - - - " appears on the temperature display	- Break in the connection between the core probe – electronic (power) card	- Check the connection to the electronic card
	- Damaged core needle probe	- Contact a qualified technician to repair the probe

5.6 Wiring layout

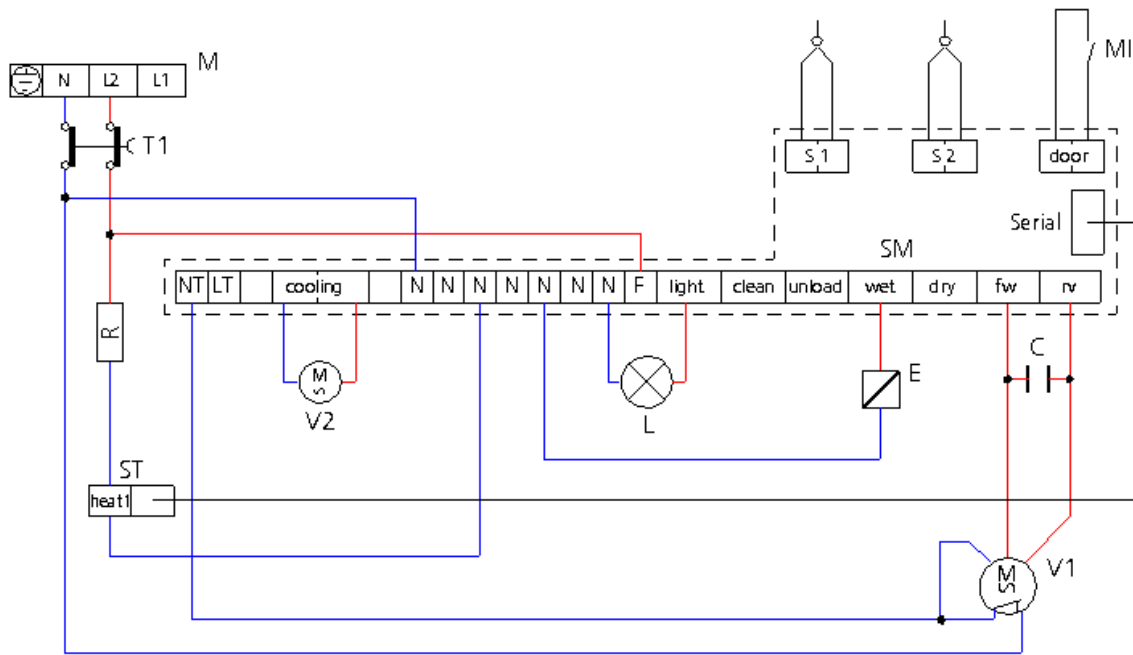

Key

M	Power supply terminal board	S2	Food core probe
R	Circular heating element	MI	Door microswitch
T1	Oven safety thermostat	C	Capacitor
V1	Radial motorised ventilator	E	Water solenoid-valve
V2	Tangential motorised ventilator	ST	"triac" card
L	Lighting lamp	SM	Microprocessor card
S1	Cooking chamber probe		

6. Technical service

Before leaving the factory, the appliance was completely regulated and tested by expert specialised personnel to guarantee the best operating results.

All repairs and settings must be performed with utmost care and attention, respecting national safety regulations in force. Always contact your retailer or our nearest Service Centre, giving details of the problem, the appliance model and the serial number (on the rating plate on the rear panel).

For any maintenance the user can contact Tecnoeka by calling the telephone numbers on the cover or going to www.tecnoeka.com.

7. Informations to the consumers

Further to Directive 2002/96/EC, the symbol of the crossed rubbish skip on the appliance means that at the end of its life, the product must be disposed of separately from the other rubbish. The user must hand the appliance to a specialised waste collection centre for electric and electronic equipment.

The separate collection of the rubbish and subsequent treatment, recovery and disposal help to produce other equipment using recycled materials, reducing the negative effects on the environment and public health, which would be caused by incorrect management of the rubbish.

Should the user dispose of the product abusively, administrative sanctions would be applied.

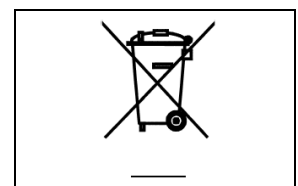

8. The Warranty

Your appliance is covered by warranty. The seller will replace or repair (and his decision will be final), free of charge for the customer, only those parts that are defective due to a manufacturing fault on condition that, under penalty of forfeiture:

- for domestic equipment, the customer notifies the fault within two months from the date when he/she discovered it and anyway within 2 years from the date of purchase;
- for professional equipment, the customer notifies the fault within 8 days from the date when he/she discovered it and anyway within 12 months from the date of purchase,

by registered letter with acknowledgement of receipt and enclosing the invoice or receipt proving the purchase.

Apart from the case when the customer cannot produce the invoice or receipt proving the purchase or when the above-mentioned terms are not complied with, the **warranty is expressly excluded** in the following cases:

- 1) faults or breakage caused by the transport;
- 2) wrong or incorrect installation of the product (for instance because of insufficient draught of the flue or exhausts) in light of the instructions given in the user's handbook supplied with the product;
- 3) inadequate or abnormal electrical, hydraulic and/or gas supplies;
- 4) carelessness, negligence or incompetence in using the product in light of the instructions given in the user's handbook supplied with the product;
- 5) use of the product for uses different from the one for which it was built or anyway in a manner not compliant with the instructions given in the user's handbook supplied with the product;
- 6) tampering with the product;
- 7) adjustments and/or maintenance and/or repairs carried out by unauthorised personnel and/or with non original spare parts;
- 8) inadequate or careless maintenance of the product in contrast with the user's handbook supplied with the product;
- 9) damages caused by fire, natural disasters and accident as well as by any cause not attributable to TECNOEKA SRL.

The warranty explicitly excludes: varnished or enamelled parts, knobs, handles, movable or removable plastic parts, bulbs, glass parts, refractories and any accessories.

TECNOEKA SRL cannot be held responsible for any damages, either direct or indirect, caused by the product breaking down or following its non-use.

Any repairs carried out during the warranty do not cause said warranty to be extended or renewed.

Nobody is authorised to modify the terms and conditions of the warranty or to issue new verbal or written warranties.

The warranty is valid only for appliances installed in the European Union.

Any dispute shall be settled by the competent Court in Padua.

Warning for the Buyer:

1. the cooking appliance is designed only for cooking purposes while the heating appliance is designed only for heating domestic environments;
2. TECNOEKA S.r.l. does not install the appliances; the seller shall be responsible for any installation carried out;
3. TECNOEKA S.r.l. cannot be held responsible for any damages, either direct or indirect, to people, pets or property caused by the appliance breaking down or following its non-use.

The Manufacturer cannot be held responsible for any inaccuracies due to misprints or mistakes in copying in this handbook. The Manufacturer reserves the right to modify the products as he deems fit, also in the interest of the user, without affecting the vital characteristics of functionality and safety.