

The Racetrack – Aurora to Chicago

BNSF's Chicago Subdivision



a route for Train Simulator 2015 by



USER MANUAL

Table of Contents

History.....	3
Operations.....	3
Locomotives and Rolling Stock.....	4
Cab Controls.....	5
F40PH Controls and Keyboard Shortcuts.....	5
Controls.....	5
Gauges and Displays.....	6
Notes:.....	6
Bi-Level Cab Coach Controls and Keyboard Shortcuts.....	7
Controls.....	7
Gauges and Displays.....	8
Notes:.....	8
Horn and Bell.....	9
Head End Power.....	9
GP38-2 Controls and Keyboard Shortcuts.....	10
Rolling Stock, Passenger.....	11
Rolling Stock, Freight.....	11
Rolling Stock, VLP.....	12
Scenarios.....	13
Career Scenarios.....	13
All Stops to Aurora, Part 1.....	13
All Stops to Aurora, Part 2.....	13
Chicago-Bound Express.....	13
Chicago Flipback.....	13
Chicago Yard Duty.....	14
Cicero Switch.....	14
Oil Empties to Eola.....	14
West Chicago Local.....	14
Tutorial Scenario.....	15
Tutorial: NS Cab Car Expert Controls.....	15
Quick Drive Scenarios.....	15
Gameplay Hints and Suggestions.....	15
Signals.....	16
Signage.....	17
Speed Limits.....	18
Track Schematics.....	19
Credits.....	26

History

The first railroad to operate here was the Aurora Branch Railroad. They began operations in 1849 along a 12 mile stretch of track from Aurora to West Chicago and connecting to the Chicago & Galena Union Railroad (later the Chicago & North Western Railroad). This original section is modeled as the West Chicago Branch.

The railroad was granted a charter to connect Aurora to Mendota, Illinois and later to connect with the Illinois Central Railroad near LaSalle. The railroad conducted a series of acquisitions and mergers and renamed itself The Chicago, Burlington & Quincy Railroad in 1855.

During this time, in 1854 the charter to connect Aurora to Chicago was granted. This section of track was constructed between 1862 and 1864 and would later be known as the racetrack. The mainline widened to its current famous triple-track configuration between Chicago and Downers Grove by 1900. In the 1920s triple track was extended to Aurora giving the route the configuration seen today.

The CB&Q debuted the Zephyrs on this route and ushered in high-speed rail service for the United States. This is also the line that ended high-speed rail service in the United States. In 1946 the Advance Flyer and the Exposition Flyer crashed just east of Naperville Station at the Loomis St crossing. Forty-five people were killed with over 100 injured. The fallout resulted in restricting all railroads to speeds less than 80mph unless a number of safety features, including in-cab signaling, were in place.

In 1970 the CB&Q merged with the Great Northern Railroad and formed the Burlington Northern. Another merger in 1995 created the BNSF Railway that operates here today. The line is the eastern terminus of BNSF's Northern TransCon, and also the eastern terminus of both BNSF's Coal Road from Wyoming and the Oil Road from North Dakota.

The facilities along the route have changed greatly over the years. Gone are much of the industry track and spur lines in Aurora, the auto facility in Naperville, and many of the roundhouses that dotted the line. Cicero Yard opened in 1958 as a hump-type freight yard. Post Santa Fe merger this facility was converted to an intermodal yard to serve the growing traffic of the Northwest and the smaller intermodal yard at Western Avenue adjacent to UP's Global 1 Yard was closed. These changes have streamlined the route to handle the growing needs of the modern industry and keep the freight and passengers moving.

Operations

The route is amenable to both commuter and freight operations. An average weekday sees over 100 passenger trains including 94 commuter trains and 8 Amtrak runs. Commuter service runs between Chicago Union Station and Aurora, stopping at 24 stations in between. Amtrak runs its Southwest Chief & California Zephyr service here and also provides local service with the Illinois Zephyr and the Carl Sandburg. There are also over 50 daily freight trains of many types, including intermodal, coal, oil, and mixed freight.

In addition there are many transfer runs, both between BNSF subdivisions in Chicago and to other railroads in the region. The route extends west to Montgomery where there are several industries to service. From Aurora, the single-track West Chicago Branch extends north and east to more industries.

The route has several rail yards, all of which have been faithfully modeled. The Hill yard, adjacent to Aurora station, is

used to stage commuter trains for eastbound runs. Eola yard, east of Aurora, is used for general freight operations. The BNSF intermodal yard in Cicero also has engine-service facilities and a freight-car shop. BNSF also has yard trackage in the Western Avenue area, running parallel to the main. Finally, as we turn north and approach Union Station, we see the 'Chicago' commuter coach yard on the west and Amtrak's coach yard and service facilities on the east.

There are several interchange points along the racetrack with connections to Canadian National, Norfolk Southern, CSX and Union Pacific. The St. Charles Air Line, a small connector line, begins as a long ramp near the Canal Street Wye. It then crosses over the coach yard on its way eastward where it connects (off route) to another CN line near Lake Michigan. NS has trackage rights over the Racetrack, as does CSX and occasionally CP. Historically, so have CN and UP.

The route as presented to the player is best suited for commuter service, yard switching & shunting, local freight delivery, and interchange operations.

Locomotives and Rolling Stock

The Racetrack route includes two types of locomotives, a cab coach, and a variety of rolling stock, all of which are representative of what you would see on the actual railroad. First the locomotives:



EMD F40PH, 'Chicago' Commuter



'Chicago' Bi-Level Cab Coach, 8500 series



EMD GP38-2, former BN



EMD GP38-2, BNSF Rebuild

Each locomotive is also available as a driverless ("ND") variant. Driverless locomotives are intended to be used when a locomotive is placed anywhere other than at the head end of a consist.

Be aware that the Bi-Level Cab Coach is blueprinted as an engine, whereas the Trailer Coach (see below) is blueprinted as a wagon. Find these items, respectively, in the Engines & Tenders and the Rolling Stock dropdown menus of the scenario editor.

Cab Controls

F40PH Controls and Keyboard Shortcuts

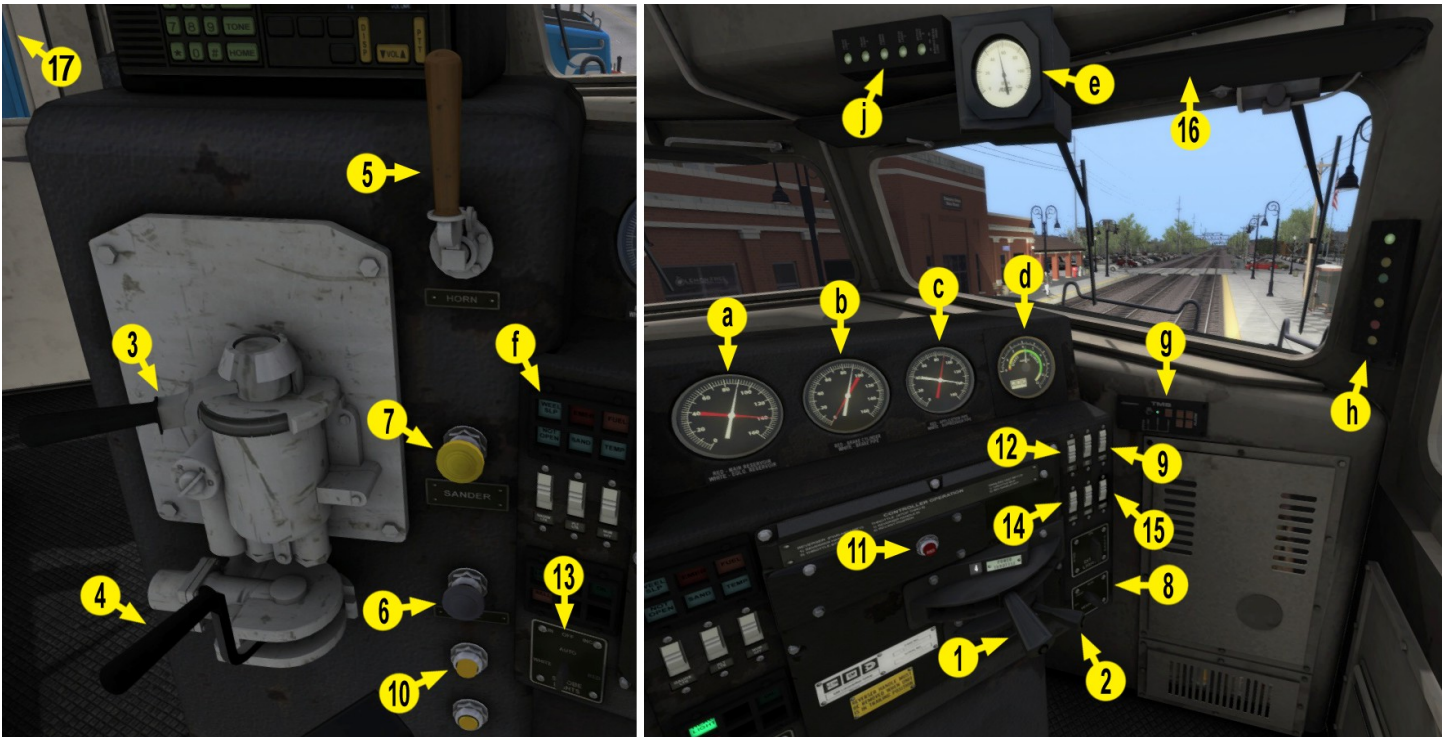

Controls

- 1 Throttle (**A / D**)
- 2 Reverser (**W / S**)
- 3 Train Brake (**;** / **'** *semicolon / apostrophe*)
- 4 Locomotive Brake (**[/]**)
- 5 Horn (**Space bar**)
- 6 Bell (**B**)
- 7 Sander (**X**)
- 8 Headlights (**H**)¹
- 9 Wipers (**V**)
- 10 Alarm Acknowledge (**Q**)
- 11 Engine Start/Stop (**Z**)
- 12 Instrument Lights (**K**)

- 13 Strobes²
- 14 Cab Signal Control Switches³
- 15 Alarm Cutout (**Ctrl D**)⁴
- 16 Sun Shade⁵
- 17 HEP Switch – on back panel (**P**)
Cab Lights (**L**)⁶

Gauges and Displays

- a Red – Main reservoir
White – Equalizing reservoir
- b Red – Brake cylinder
White – Brake pipe
- c Red – Application pipe⁷
White – Suppression pipe⁷
- d Ammeter
- e Speedometer
- f Wheel Slip
- g Speeding/Vigilance Alarm⁸
- h Signal Aspect Display⁹
- j Headlight Display¹⁰

Notes:

- 1 Headlights are controlled in the traditional manner: 0 = off; 1 = forward; 2 = reverse.
- 2 The “white” strobe (actually it's amber) also operates automatically whenever the bell is ringing.
- 3 This is a pair of switches that should normally be left in the default (up) position. In the OFF position, in non cab-signal territory only, they will disable the cab signal display.
- 4 In the default (up) position, this switch disables penalty braking. Penalty braking will occur after a set time period following initiation of a speeding or vigilance alarm. Click on the switch if you wish to enable penalty braking.
- 5 Both of the engineer's sun shades are operable with the mouse only.
- 6 The cab light switch is on the ceiling next to the light itself (engineer's side only).
- 7 A speeding alarm is canceled when the engineer places the train brake in the suppression notch. In actual practice, these gauges serve as a reference so the engineer can continue watching the tracks ahead. In Train Simulator, these are simulated pressure gauges.
- 8 The TMS (Train Management System) displays a visual alarm, followed shortly thereafter by an audible alarm when either of the following happens: The engineer does not operate the throttle or brake controls for 90 seconds (vigilance alarm); or the train speed exceeds the track speed limit (speeding alarm). A vigilance alarm is canceled by pressing the Alarm Acknowledge button in the cab, the Q key, or the alarm icon on the driver HUD. A speeding alarm is canceled by applying suppression braking (or using shortcut key **Shift ' (Shift apostrophe)** to slow the train. In actual practice, failure to respond to either of these conditions will initiate penalty braking. In this simulation, penalty braking is normally disabled (see Note 4).

- 9 The Aspect Display Unit displays the status of the next set of signals. From top to bottom: Clear (green), Approach Limited/Approach Medium (yellow over green), Approach (yellow), Restricted (red over yellow).
- 10 This display helps the engineer confirm which of the locomotive's forward lights are on.
- 11 F40PHs used in commuter service in Chicago utilize blended braking so there is no separate dynamic brake control.

Bi-Level Cab Coach Controls and Keyboard Shortcuts

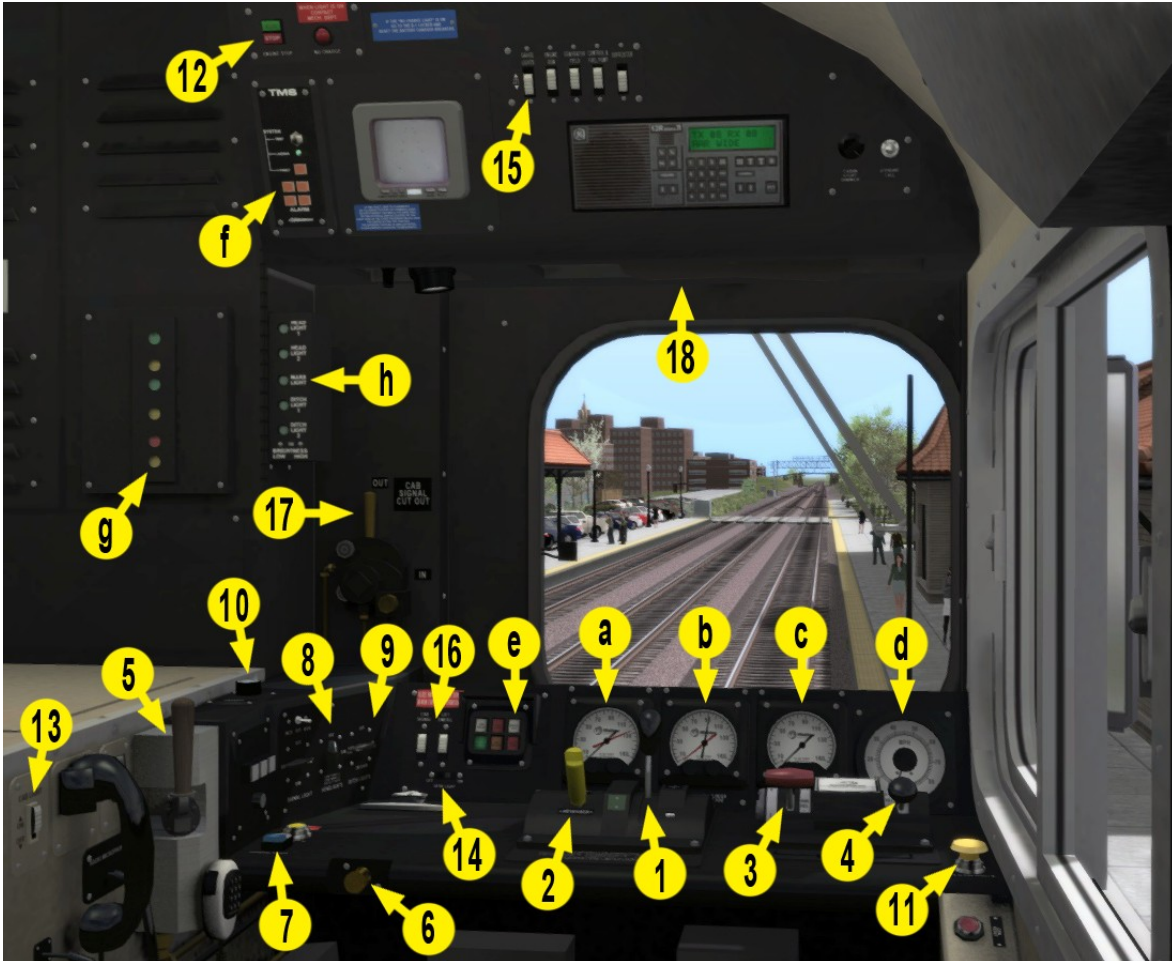

Controls

- 1 Throttle (**A / D**)
- 2 Reverser (**W / S**)
- 3 Train Brake (**;** / **'**) *semicolon / apostrophe*)
- 4 Locomotive Brake (**[/]**)
- 5 Horn (Space bar)
- 6 Bell (**B**)
- 7 Sander (**X**)
- 8 Headlights (**H**)²
- 9 Ditch Lights³

- 10 Wipers (**V**)
- 11 Alarm Acknowledge (**Q**)
- 12 Engine Start/Stop (**Z**)
- 13 Cab Lights (**L**)⁴
- 14 Desk Lights (**J**)⁴
- 15 Gauge Lights (**K**)
- 16 Cab Signal Control Switches
- 17 Alarm Cutout (**Ctrl D**)⁵
- 18 Sun Shade (**U**)
Cab Windows⁶

Gauges and Displays

- a Red – Main reservoir
Black – Equalizing reservoir
- b Red – Brake cylinder
Black – Brake pipe
- c Red – Application pipe
Black – Suppression pipe
- d Speedometer
- e Wheel Slip
- f Speeding/Vigilance Alarm
- g Signal Aspect Display
- h Headlight Display

Notes:

For the most part, the notes for the F40PH controls also pertain to the Cab Coach controls. Exceptions and additions are as follows:

- 1 The headlight switch has a dim position and bright position. Use the dim light in places like Chicago Union Station to reduce over-illumination of close-in features. Both the H key shortcut and the driver HUD headlight switch override the manual switch, causing the headlights to operate in traditional 0-1-2 fashion.
- 2 The ditch light switch defaults to the AUTO position. It also functions in the other positions: OFF, Continuous ON, and Continuous FLASH.
- 3 You can also mouse-click on the light itself to toggle it on and off.
- 4 In the cab coach this pneumatic switch ties directly into the brake system. The default (OUT) position disables penalty braking. Move the handle to the IN position (or use shortcut key **Ctrl D**) if you wish to enable penalty braking.
- 5 Both of the window panels on the engineer's side can be operated using the mouse.

Horn and Bell

In both the F40PH and the cab coach, activating the horn will also cause the bell to ring and the ditch lights to flash for a set time period. Switching the bell on by itself will cause the bell to ring and the ditch lights to flash until the bell is manually switched off. Commuter trains should use only the bell in the quiet zones (QZ) of the Racetrack in advance of grade crossings and station platforms. Use of the horn in quiet zones is permitted only when passing another train stopped at a station, when approaching a work zone, or to avoid an emergency situation. The Racetrack is designated as QZ between Mileposts 33 & 0.

Head End Power

Passenger locomotives move the train over the rails, but more often than not they must also supply electrical power to the passenger consist. The F40PHs used for commuter service in Chicago are a good example of this kind of duty. In order for the locomotive's generator to supply this "head-end power" (HEP), the prime mover must operate continuously at 900 rpm. In normal operation, the locomotive's speed is controlled by varying the rpm of the prime mover. In HEP mode, speed is controlled by varying the generator excitation.

In Train Simulator, a player train can be operated in HEP mode – or not – at the player's option. HEP mode currently has no effect on locomotive performance. A HEP switch is provided on the back panel in the F40PH cab which can be toggled on and off by clicking on it, or by using the **P** key. In HEP mode, the rpm indicator on the player HUD ramps up from the 315 rpm idle rate to a maximum of 900 rpm in about 45 seconds. The locomotive audio is adjusted in response to the current rpm value.

You can also initiate HEP mode in scenarios that feature operation of the train from the cab coach. In cab view, briefly enter the F40PH cab (**Ctrl +**), throw the HEP switch, and return.

F40PHs in AI trains operate in HEP mode by default. F40PHs in Free Roam scenarios start in HEP mode but if the locomotive is drivable, HEP mode can be turned off, or back on, as desired.

GP38-2 Controls and Keyboard Shortcuts



- | | |
|---|--|
| 1 Train Brake (; / ' <i>semicolon / apostrophe</i>) | 8 Reverser (W / S) |
| 2 Locomotive Brake ([/]) | 9 Step Lights (K) |
| 3 Horn (Space Bar) | 10 Wipers (V) |
| 4 Sander (X) | 11 Headlights (H) |
| 5 Bell (B) | 12 Cab Light (L) |
| 6 Dynamic Brake (. / , <i>period / comma</i>) | 13 Engine Start/Stop (Z) |
| 7 Throttle (A / D) | 14 Strobe Light, when so equipped (C) |

Rolling Stock, Passenger



'Chicago' Bi-Level Coach, 6000 series

Rolling Stock, Freight



Boxcar



Tank Car



Refrigerator Car



Covered Hopper



Coal Hopper

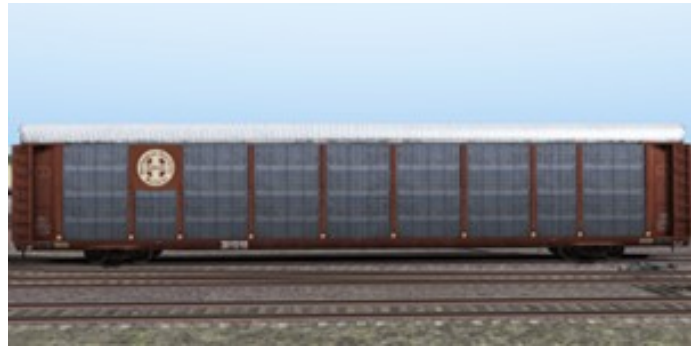

Autorack



Double-stack Well Car

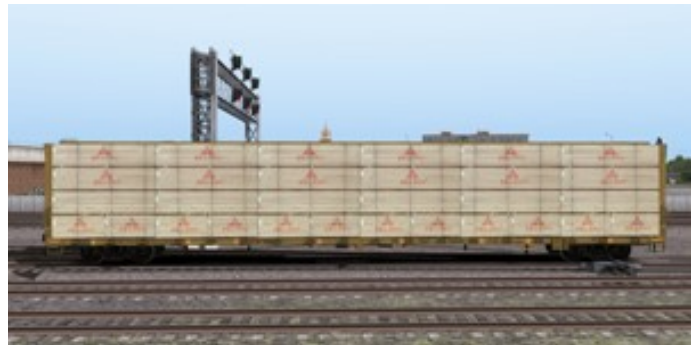

Centerbeam Flatcar



Caboose

Rolling Stock, VLP

Very Low Poly (VLP) railcars are provided for the purpose of populating yard areas without overly challenging the capabilities of our graphics hardware. VLP stock typically has low-resolution textures, little or no surface detail, opaque windows and no interiors. VLP items include a 'Chicago' commuter train set (F40PH locomotive, trailer coach and cab coach), and an Amtrak intercity train set (P42DC locomotive, Superliner coach). The 'Chicago' commuter train set is comprised of “wagons” only, including the locomotive. Use VLP commuter train sets in the western portion of the Chicago coach yard, and in the Hill yard at Aurora. For player or AI commuter trains, use the fully developed models described in the previous sections. VLP intercity train sets can be used in the eastern, Amtrak portion of the Chicago coach yard or in AI duty. The Quick Drive scenarios included in this package illustrate how VLP items can be used.

Scenarios

Career Scenarios

All Stops to Aurora, Part 1

Chicago Commuter Train 1233 is an early afternoon, all-stops local from Chicago Union Station to Aurora, Ill. Between Union Station and Aurora, Train 1233 makes 24 intermediate station stops. In this first of a two-part scenario, you will be making the run from Union Station to the 15th stop along the Chicago Subdivision at Hinsdale. Power for your consist of bi-level gallery cars is a veteran EMD F40PH.

Duration – 45 minutes
Weather – Snow / Winter

Locomotive – EMD F40PH
Departure – 1:28 pm

All Stops to Aurora, Part 2

In this continuation of “All Stops to Aurora,” you have reached and completed your passenger loading at Hinsdale and are ready to proceed westbound on the Chicago Subdivision to Aurora. There are nine additional intermediate stops en route. In traditional fashion on the line, your F40PH locomotive is leading this westbound consist.

Duration – 40 minutes
Weather – Snow / Winter

Locomotive – EMD F40PH
Departure – 2:15 pm

Chicago-Bound Express

Chicago Commuter Train 1204 is an early morning run that, after originating in Aurora, makes local stops as far as Downers Grove. It then operates express all the way to Chicago Union Station. Typical of operations on the route, Train 1204 is a push-pull consist with its locomotive on the west end, so as engineer you'll be working from the cab of a bi-level control car.

Duration – 55 minutes
Weather – Cloudy / Autumn

Locomotive – 'Chicago' Bi-Level Cab Coach
Departure – 5:23 am

Chicago Flipback

During the rush hours on the Racetrack, select trains operate as “flipbacks.” Chicago Commuter Train 1209 is a morning flipback that operates from Chicago Union Station only as far west as Westmont. It then flips back east to Chicago as Train 1234 making stops from Westmont to Congress Park. You are the engineer of the westbound flipback making its stop at Hinsdale, and you'll soon be changing ends to make the run back to Chicago.

Duration – 50 minutes
Weather – Cloudy / Summer

Locomotive – EMD F40PH
Departure – 7:04 am

Chicago Yard Duty

Those commuter trains you see on the Racetrack are made up of individual cars and sooner or later each of them needs a little preventive maintenance and cleanup. Today you'll assemble a commuter train with several recently checked-out coach cars.

Duration – 50 minutes
Weather – Cloudy / Summer

Locomotive – EMD GP38-2
Departure – 11:30 am

Cicero Switch

You are the engineer of a BNSF Cicero switch job, ready to begin your afternoon trick. Your immediate task will be fueling your locomotive, then assembling a westbound intermodal consist in the sprawling Cicero intermodal facility. As power you have a pair of BNSF EMD GP38-2s.

Duration – 40 minutes
Weather – Cloudy / Summer

Locomotive – EMD GP38-2
Departure – 3:00 pm

Oil Empties to Eola

You are the engineer of a BNSF transfer job coming from Norfolk Southern's Ashland Avenue Yard via the Western Avenue Corridor and bound for BNSF's yard at Eola, Illinois. Your train is an empty unit crude oil consist bound back west for loading and your power is a trio of BNSF Electro-Motive GP38-2s.

Duration – 60 minutes
Weather – Cloudy / Spring

Locomotive – EMD GP38-2
Departure – 6:00 pm

West Chicago Local

The Chicago Subdivision's West Chicago Branch is very different indeed from its bustling three-track mainline "racetrack." Stretching some 10 miles from Aurora to West Chicago, the branch is served by "up one day and down the next" local freights that originate at Eola. You are the engineer of a southbound turn, ready to begin the morning's work at West Chicago and then make your way toward Aurora.

Duration – 70 minutes
Weather – Rain / Summer

Locomotive – EMD GP38-2
Departure – 7:00 am

Tutorial Scenario

Tutorial: NS Cab Car Expert Controls

Learn the controls of the Bi-Level Cab Coach and familiarize yourself with the Chicago Sub.

Duration – 10 minutes
Weather – Clear / Summer

Locomotive – 'Chicago' Bi-Level Cab Coach
Departure – 12:25 pm

Quick Drive Scenarios

The Racetrack route is Quick Drive ready. To simulate prototypical commuter operation, choose either the EMD F40PH locomotive with the **Chicago Commuter Westbound** consist for westbound runs (Chicago to Aurora), or the NS Bilevel Cab Coach and **Chicago Commuter Eastbound** consist for eastbound runs (Aurora to Chicago). Westbound runs depart from Union Station Platform 2 or any of the 'WB' stations. Eastbound runs depart from Aurora Platform 2 or any of the 'EB' stations.

You can also run freight train Quick Drives. Freight trains may depart from the Mendota Entry point at the westernmost end of the route and terminate at the Western Avenue Yard, or they can travel in the opposite direction starting at Western Avenue.























Gameplay Hints and Suggestions

For best results, plan on allocating the full duration of time listed with each scenario to your operating session.

Not interested in the recording a score in a Career Scenario? In the Main Menu, click Settings, then click Gameplay and turn the Score Career Scenarios item Off.

Signals

A variety of signal types can be seen on the route, representing different stages of upgrade. Most of the signals are the modern, hooded Safetran style, although some older signals styles are also present. The signal aspects display in accordance with the following BNSF rules. Also shown are the corresponding cab ADU displays. Dwarf signals display the same aspects as high signals

Rule	Aspects	Cab ADU	Name	Indication
9.1.3			CLEAR	Proceed.
9.1.4			APPROACH LIMITED	Proceed prepared to pass next signal not exceeding 60 MPH and be prepared to enter diverging route at prescribed speed.
9.1.5			ADVANCE APPROACH	Proceed prepared to pass next signal not exceeding 50 MPH and be prepared to enter diverging route at prescribed speed.
9.1.6			APPROACH MEDIUM	Proceed prepared to pass next signal not exceeding 40 MPH and be prepared to enter diverging route at prescribed speed.
9.1.7			APPROACH RESTRICTING	Proceed prepared to pass next signal at restricted speed. (Note: <i>restricted speed is usually 15 MPH but can be less.</i>)
9.1.8			APPROACH	Proceed prepared to stop at next signal, trains exceeding 30 MPH immediately reduce to that speed. (Note: <i>Speed is 40 MPH for Amtrak and Commuter trains.</i>)
9.1.9			DIVERGING CLEAR	Proceed on diverging route not exceeding prescribed speed through turnout.
9.1.11			DIVERGING APPROACH MEDIUM	Proceed on diverging route not exceeding prescribed speed through turnout prepared to pass next signal not exceeding 35 MPH.
9.1.12			DIVERGING APPROACH	Proceed on diverging route not exceeding prescribed speed through turnout; approach next signal preparing to stop, if , exceeding 30 MPH immediately reduce to that speed. (Note: <i>Speed is 40 MPH for Amtrak and Commuter trains.</i>)
9.1.13			RESTRICTING	Proceed at restricted speed.
9.1.15			STOP	Stop.

Signage

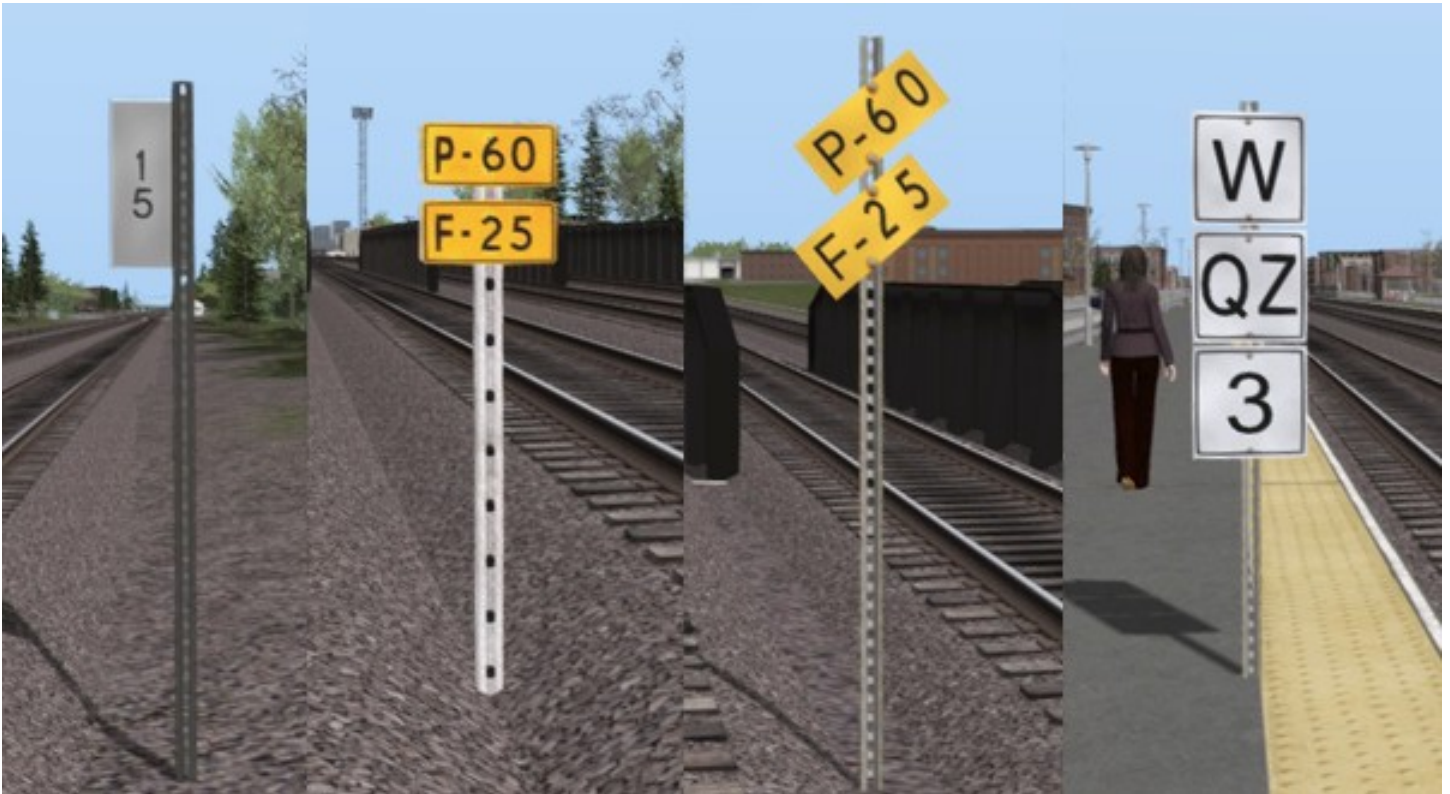

Left to Right: Milepost; Speed Limit (P = Passenger, F = Freight); Reduced Speed ahead; Whistle. Whistle signs may be accompanied by an optional 'QZ' sign and an optional number sign as shown here.

QZ stands for “Quiet Zone.” The Racetrack between Aurora and Chicago is a quiet zone. Accordingly, engineers must not use the horn at grade crossings or to signal train movements in quiet zones; the bell is used instead. Activating the bell also causes the ditch lights to alternately flash. In Quiet Zones, the horn may be used only when passing a train stopped at a station.

The number sign, where present, warns that the indicated number of grade crossings are directly ahead and in quick succession.

Points west of Aurora (Milepost 33) and along the West Chicago Branch are not designated Quiet Zones and appropriate horn usage is expected.

Speed Limits

The speed limit on most of the racetrack main line is 70 mph for passenger service and 50 mph for freight service (P-70/F-50), with the following major exceptions.

- P-65/F-45 on the main line from just west of Fairview Ave station to west of Downers Grove.
- P-60/F-25 on the main line beginning west of Western Ave station and points east; then reduced to P-40/F-20 about midway to Halsted St station; then reduced again to P-25/F-10 at approach to Canal Street Wye.
- P-55/F-40 on the main line beginning west of Eola yard and westward; then P-35/F-35 at the Fox River crossings; then P-79/F-50 from east approach to Montgomery and points west.
- P-35/F-20 beginning at the branch into Hill Yard, reduced to P-20/F-20 in the Aurora platform area.
- P-35/F-35 at most crossovers, though some are P-30/F-30.
- P-20/F-20 on most of the West Chicago Branch; reduced to P-10/F-10 at Hill yard approach.
- P-15/F-15 or P-10/F-10, as posted, in industrial sidings and spurs.
- P-10/F-10 in Hill Yard, Eola Yard, Cicero Yard, Hawthorne Yard, Western Ave Yard, UP Global 1 Yard, both Chicago Coach Yards and inside Chicago Union Station.

The preceding is for general guidance only. Other exceptions exist. Always watch for trackside speed signs and keep an eye on the driver's HUD.

Track Schematics

Overall Route Schematic

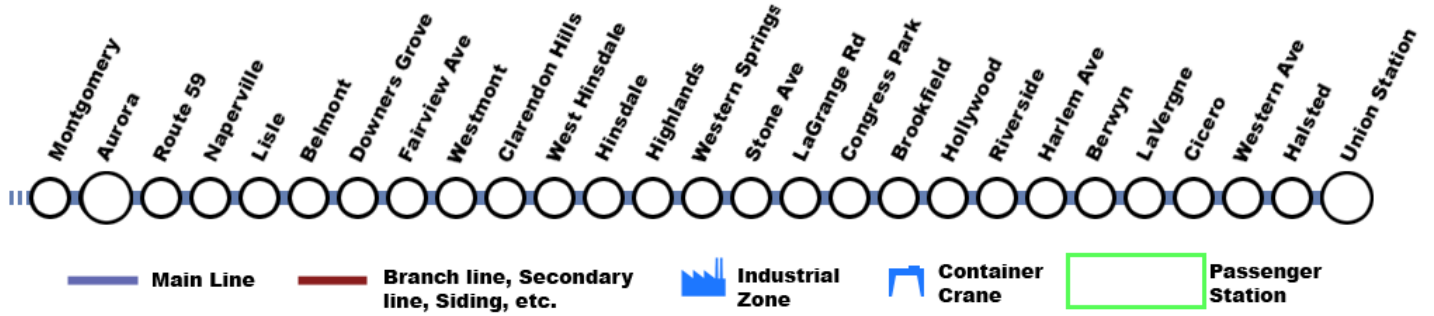

Montgomery

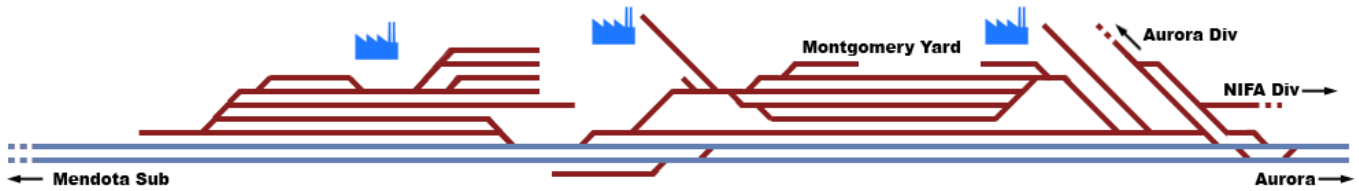

West Chicago Branch



Aurora

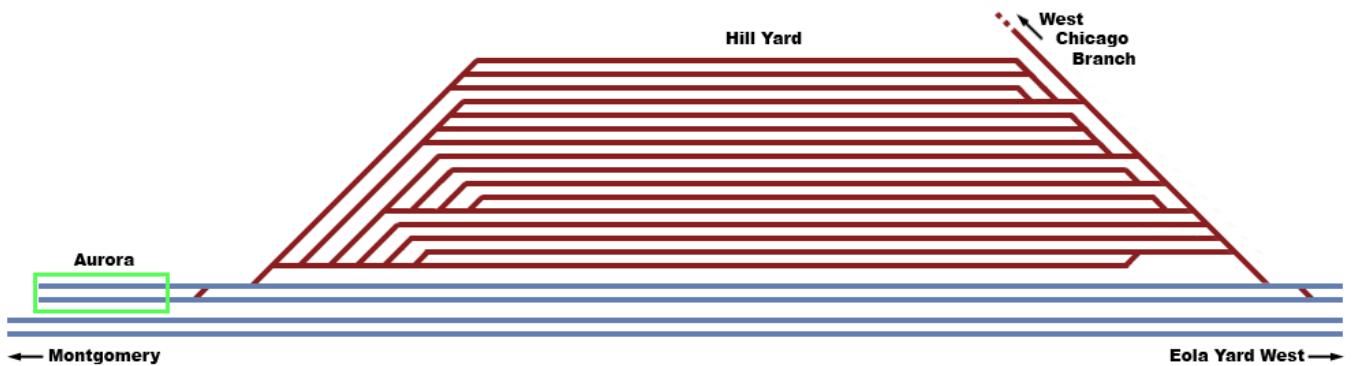

Eola Yard West

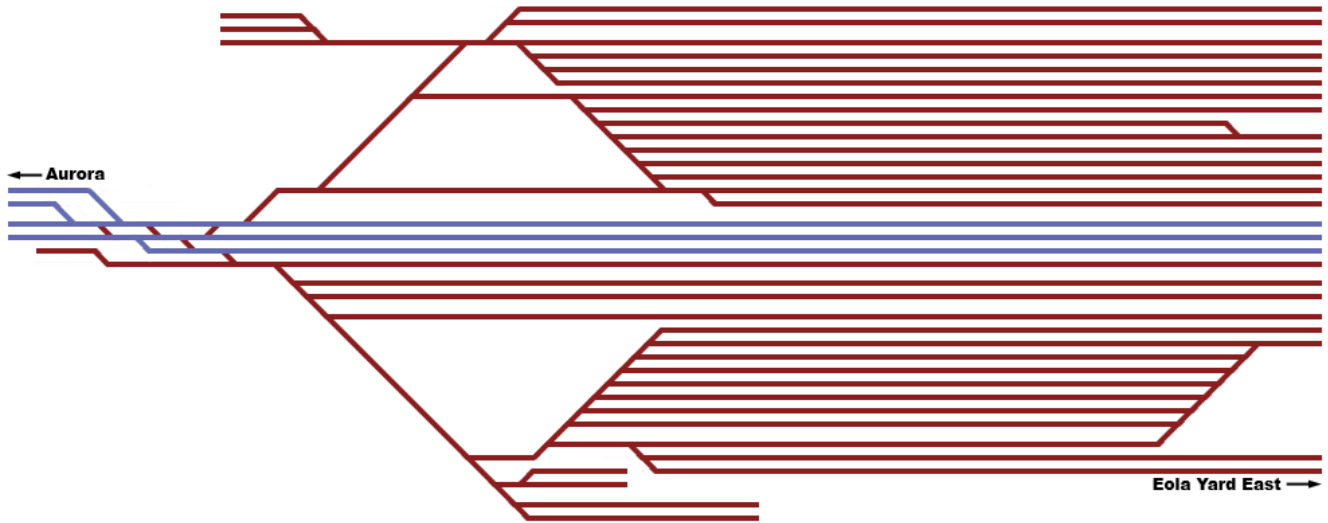

Eola Yard East

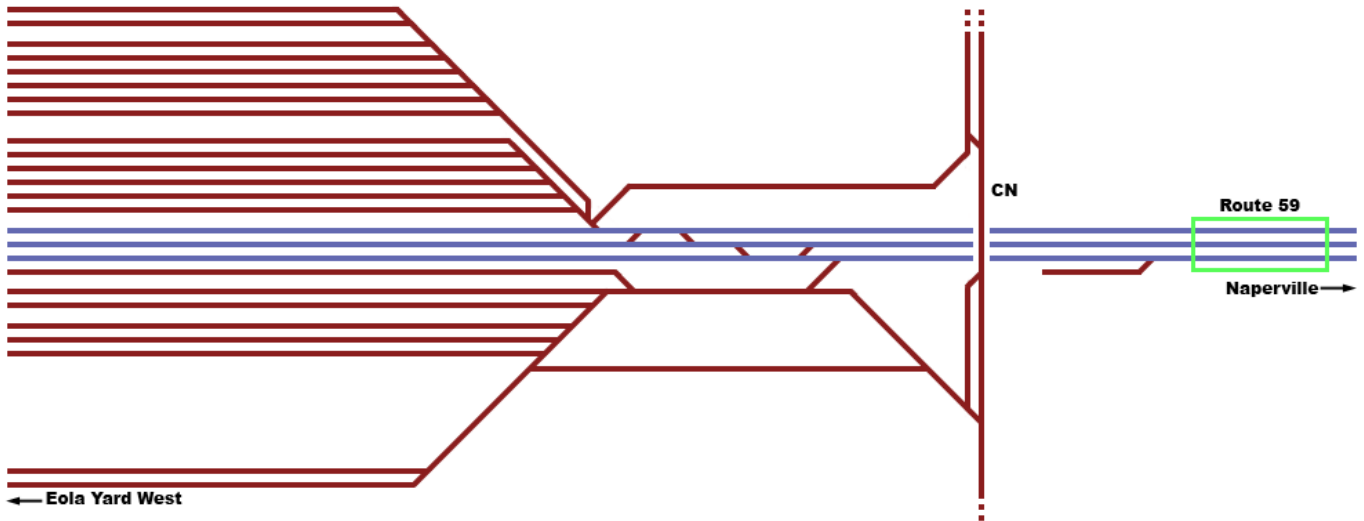

Naperville

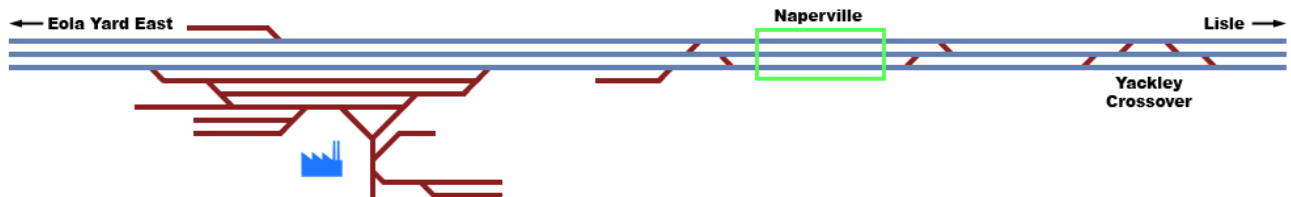

Lisle – Fairview Ave

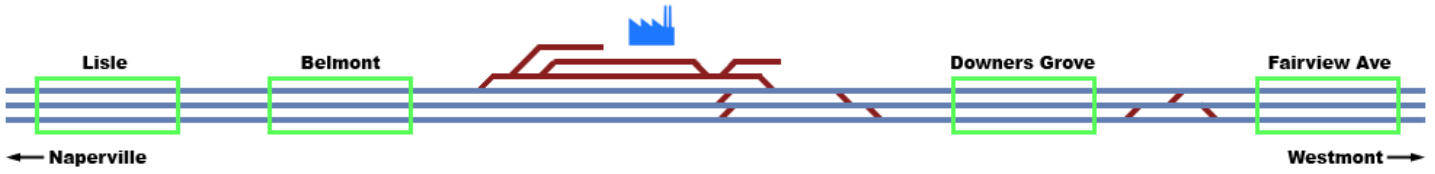

Westmont – Highlands

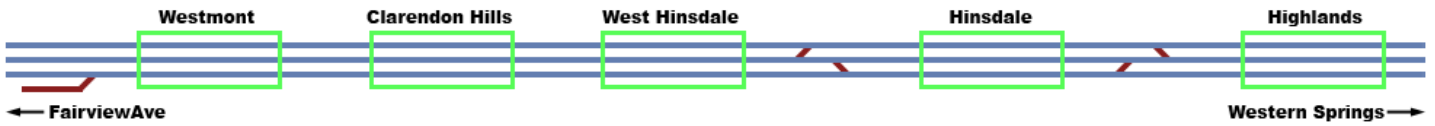

Western Springs – Congress Park

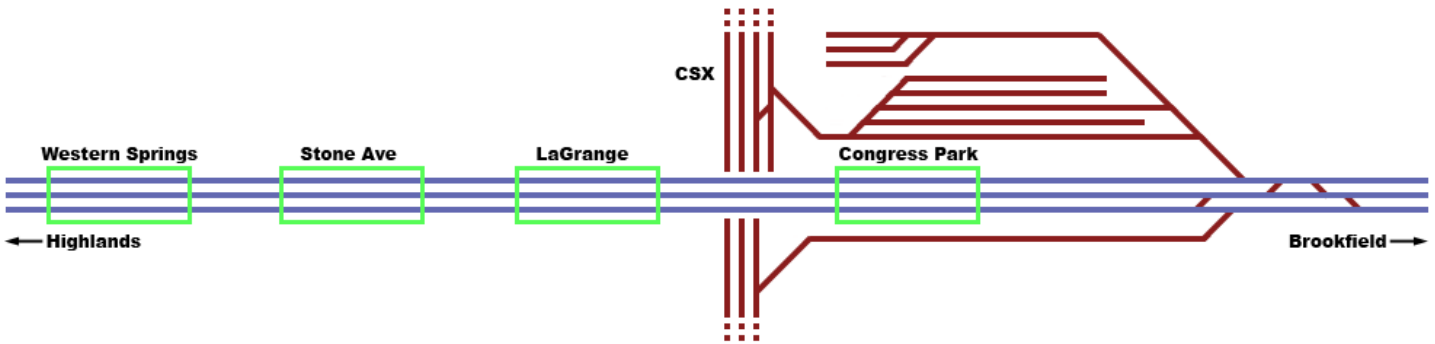

Brookfield – Laverne



Cicero Yard West

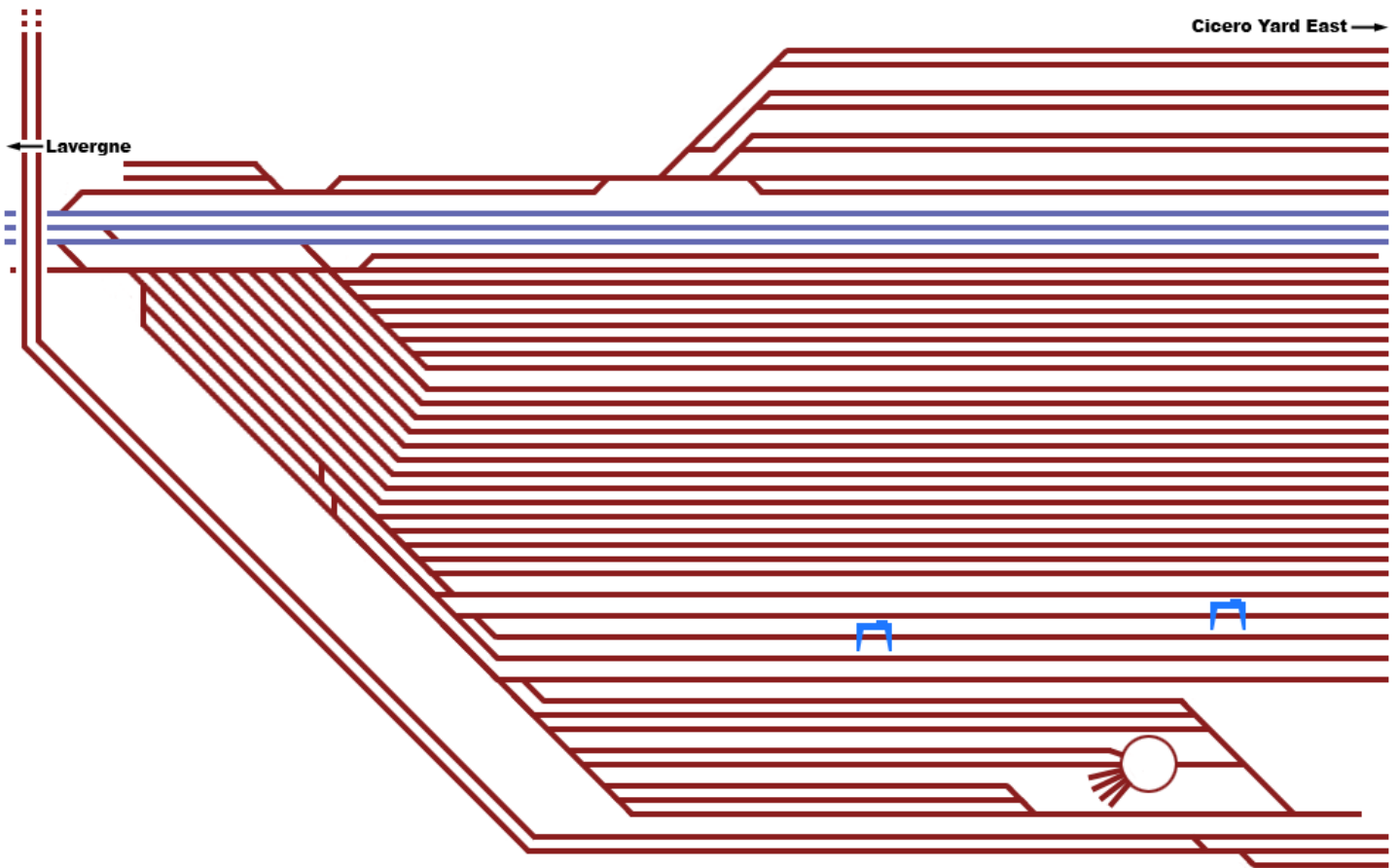

Cicero Yard East

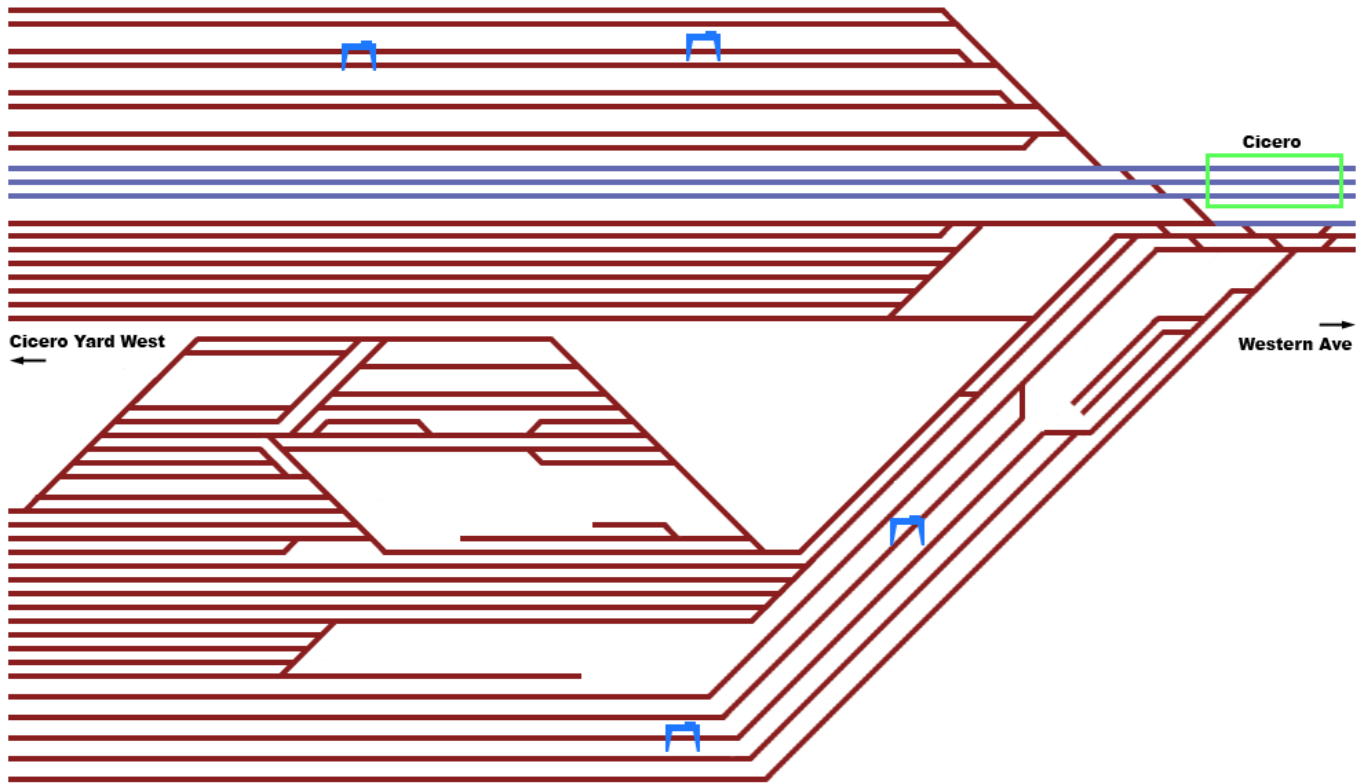

Hawthorne Yard



Cicero – Western Ave

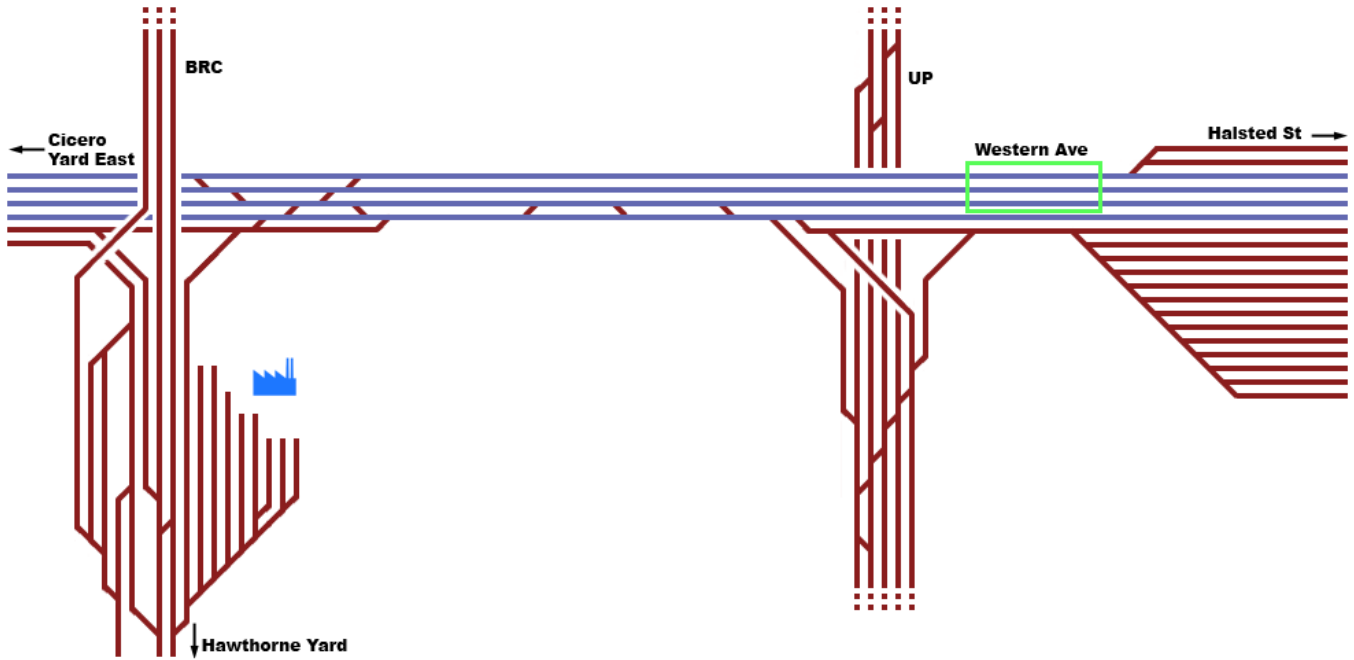

Western Ave – Halsted St

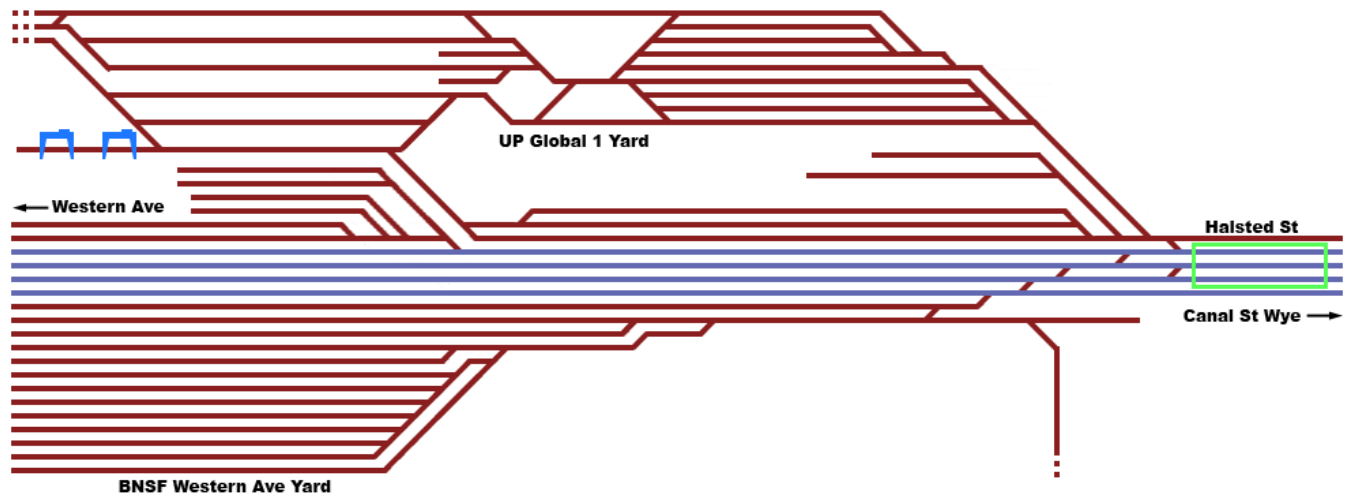

Canal Street Wye and Coach Yards

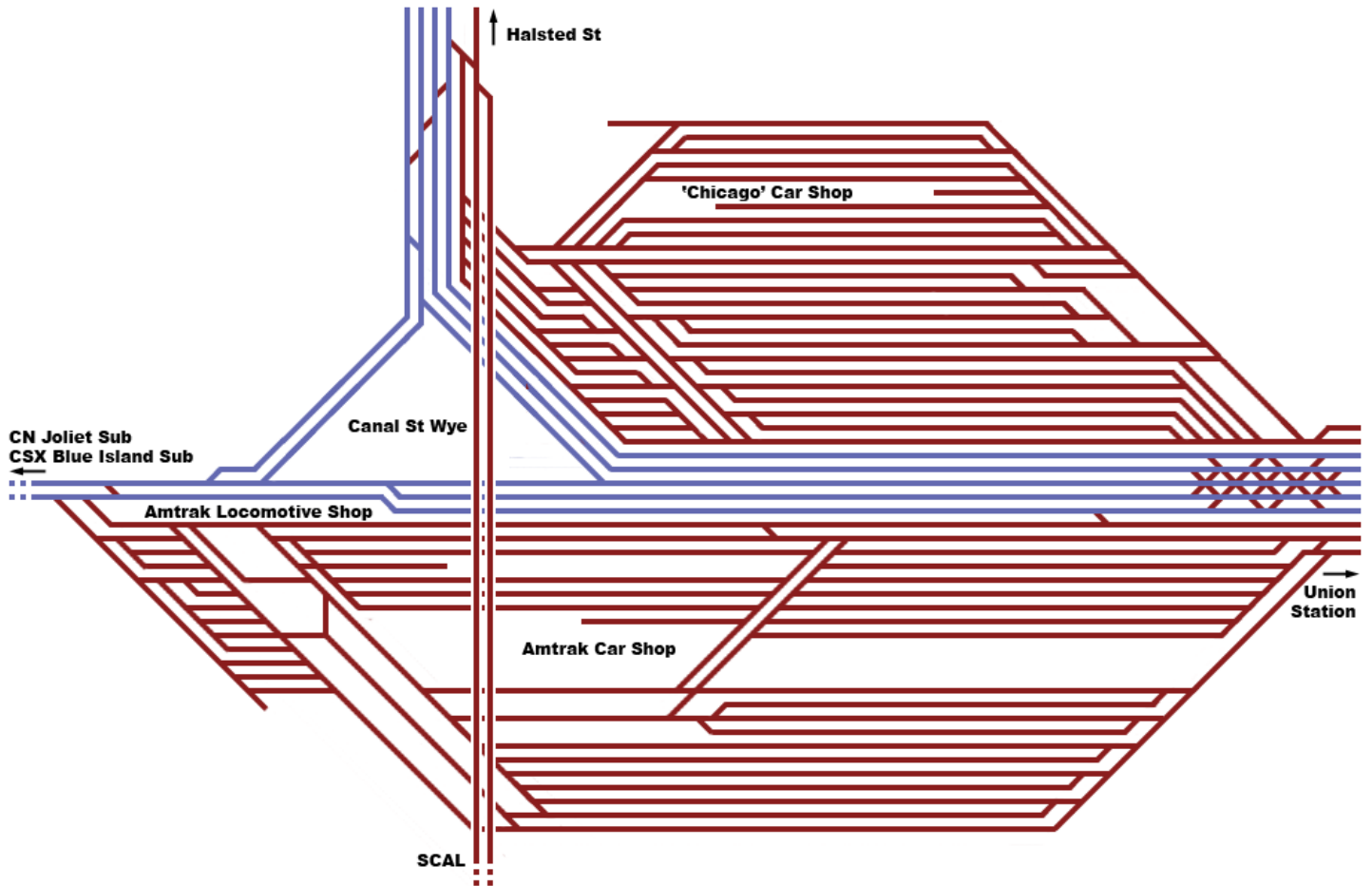

Chicago Union Station

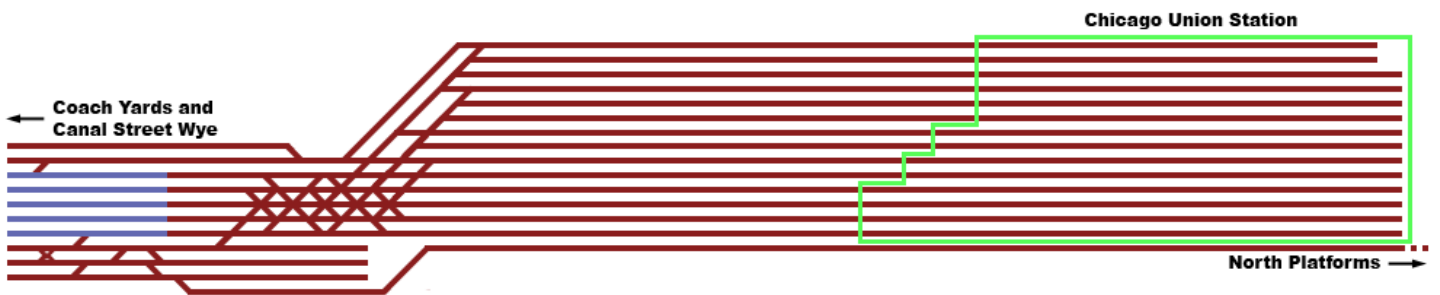

Credits

Route by Joseph Barnes and Rick Grout.

Contributors:

Procedural terrain texturing and vegetation: Wayne Campbell

Additional Models: Rich Chargin, Mike Durdan, Jonathan Lewis, Marc Nelson, and Skyhook Games (David Harper and Jon Greenwell)

Career Scenarios: Gary Dolzall

Locomotives and rolling stock were provided by Dovetail Games, except for double-stacks and 'Chicago' coaches by Rick Grout. Modifications to DTG F40PH, GP38-2, centerbeam flatcar, and caboose by Rick Grout.

Selected assets were provided by DTG and its predecessors and are used as is or as modified by the authors. Some textures were outsourced and are used in whole, in part, or in combination with original artwork by the authors in accordance with terms and conditions specified by the suppliers, who are as follows: photoshoptextures.com, backtoessentials.com, arsgrafik.com, mayang.com, cgtextures.com, absolutetextures.com.