

**INSTRUCTION MANUAL**

**Hornet / Hornet Plus / Sediment Sampler**  
**Cableway Gauging System**  
**Model Hornet/Hornet Plus/Hornet SS**



QUALITY SYSTEM  
ISO:9001  
CERTIFIED

HYQUEST SOLUTIONS PTY LTD  
PO BOX 332, LIVERPOOL B.C NSW 1871, AUSTRALIA  
Phone:(Int.) 612 9601 2022 Fax: :(Int.) 612 9602 6971  
Phone:(Nat.) (02) 9601 2022 Fax: :(Nat.) (02) 9602 6971  
Email: [sales@hyquestsolutions.com.au](mailto:sales@hyquestsolutions.com.au)  
Web: [www.hyquestsolutions.com.au](http://www.hyquestsolutions.com.au)

**TABLE OF CONTENTS**

<b>1.</b>	<b>Introduction.....</b>	<b>3</b>
<b>2.</b>	<b>Product Overview .....</b>	<b>3</b>
<b>3.</b>	<b>Installation.....</b>	<b>4</b>
3.1	Unpacking Your Hornet / Hornet Plus.....	4
3.2	Installing the Controller & Motor Drive.....	5
3.3	Installing the Far Side .....	8
3.4	Installing the Traveller Block.....	10
3.5	Installing the Traversing Cable.....	12
3.6	Attaching the Batteries and the Winch to the Traveller Block .....	19
3.7	Installing the Hoist .....	20
3.8	Fitting the Drive Control Interlock Box to the Main Cable .....	22
3.9	Attaching the Current Meter and Gauging Weight to the Hoist .....	23
<b>4</b>	<b>Operation.....</b>	<b>24</b>
4.1	Initial Power Up.....	24
4.2	Brief Description of Controls .....	25
4.3	Menu Operation.....	27
4.3.1	Main Display .....	28
4.3.2	Airline / Wetline / Corrected Depth Display (Hornet Plus only) .....	29
4.3.3	Signal Strength and Battery Voltage .....	29
4.3.4	Zero Functions .....	30
4.3.5	More.....	31
4.3.6	Hoist.....	32
4.3.7	Drive Control.....	33
4.3.8	Remote.....	34
4.3.9	Alarms.....	35
4.3.10	Return to Main Display.....	36
4.4	System Operational Steps .....	36
4.5	The Hoist .....	37
4.5.1	The Current Meter (Hornet Plus only).....	37
4.5.2	The Hoist Depth and Angle Measurement (Hornet Plus only) .....	38
4.6	The Drive Control System .....	38
<b>5.</b>	<b>Specifications.....</b>	<b>39</b>
<b>Appendix A.</b>	<b>Routine Maintenance .....</b>	<b>41</b>
<b>Appendix B.</b>	<b>Startup Guide – Hornet Plus .....</b>	<b>42</b>
<b>Appendix C.</b>	<b>Troubleshooting Guide .....</b>	<b>44</b>
<b>Appendix D.</b>	<b>Corrected Depth Calculation .....</b>	<b>51</b>
<b>Appendix E.</b>	<b>Ground Feeler Device Model GFD .....</b>	<b>52</b>
<b>Appendix F.</b>	<b>Adding Control to Drum Cable.....</b>	<b>55</b>
<b>Appendix G.</b>	<b>Sediment Sampler Hoist.....</b>	<b>56</b>
<b>Appendix H.</b>	<b>Far Side Installation Guide .....</b>	<b>60</b>

# 1. Introduction

The Hornet / Hornet Plus / Sediment Sampler has been developed to replace manned cableways, thus removing the personal injury risk associated with this type of gauging. The standard Hornet can use an ADCP to measure discharge and the Hornet can use either an ADCP or a mechanical Current Meter attached to a suitable Gauging weight to measure discharge and the Sediment Sampler can use an ADCP, mechanical current meter and a Depth Integrating Sediment Sampler.

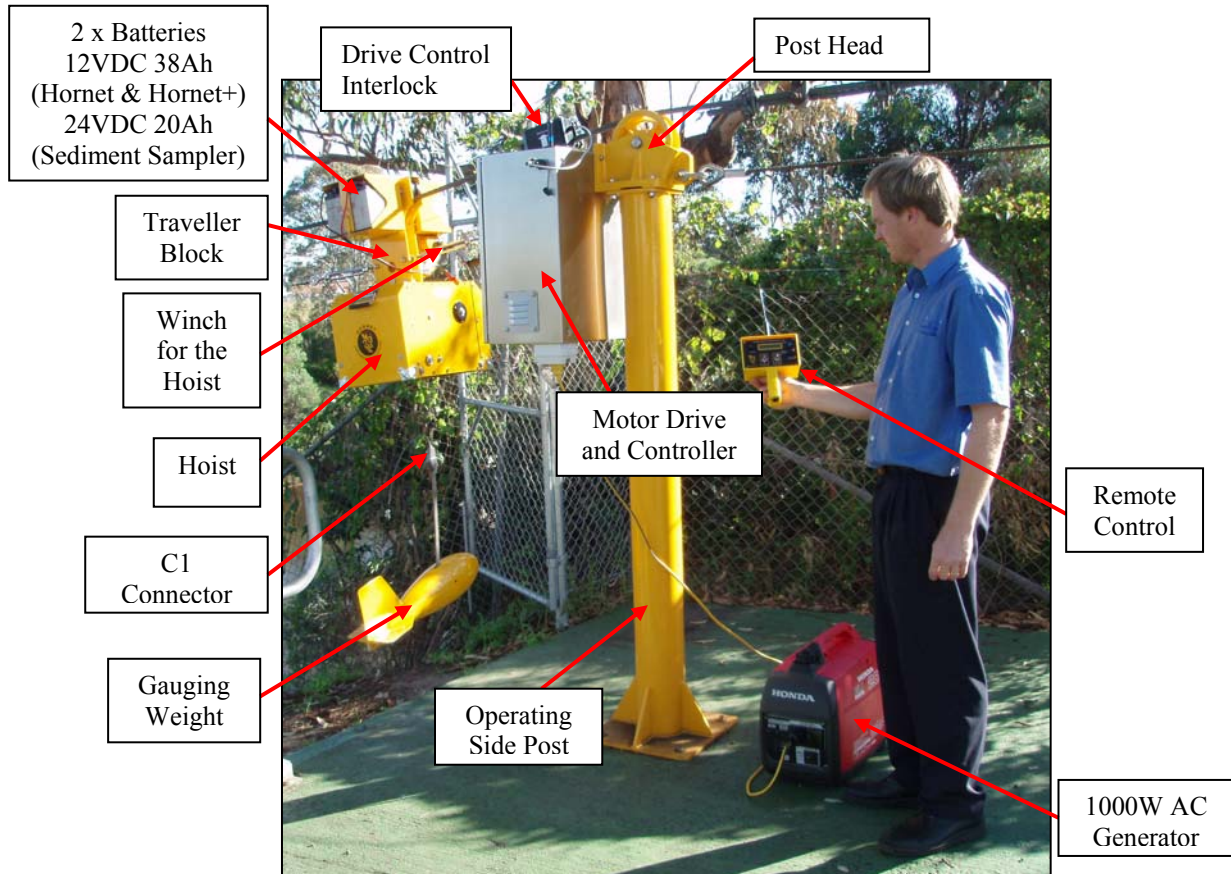

(The Hornet Plus uses an advanced Hoist that can measure depth, cable angle and current meter counts and sends the information to the Remote Control.)

# 2. Product Overview

The Hornet / Hornet Plus / Sediment Sampler is operated from the bank of a stream or river. Using a handheld remote control, the operator can maneuver the flow sensing device with the push of a switch, to traverse the waterway section to be measured.

The control system operates an electric motor to drive the carriage and hoist from the operating side to the far side of the waterway and back to the starting point. The operator uses the Remote Control to raise and lower the flow sensing device from the water via the Hoist.

### 3. Installation

#### 3.1 Unpacking Your Hornet / Hornet Plus

When you receive the Hornet / Hornet Plus, you will receive the following with it:

1. Hoist
2. Remote Control
3. Remote Control Battery Charger
4. Safety Sensor
5. Controller & Motor Drive
6. Far Side Return Sheave
7. 2x Battery Boxes
8. Traveller Block Assembly
9. Manual Winch for the Hoist
10. Traversing Cable (Optional)
11. Turnbuckles
12. Thimbles & Wire Rope Grips (Optional)
13. 2 Spare 50 Amp Fuses for Hoist
14. Weather Cover

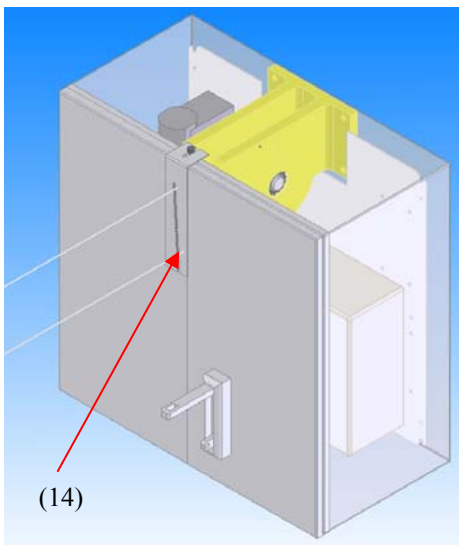
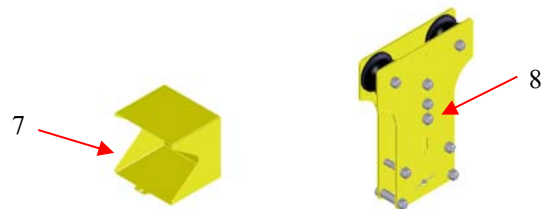
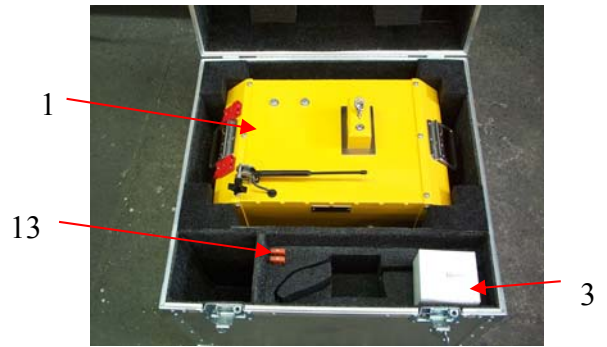

(14)

The seal is essential in wet weather to minimise the amount of water going inside the enclosure.

**Note:**

Hyquest Solutions can supply drawings for the steelwork if a new Travellerway installation is required.

### 3.2 Installing the Controller & Motor Drive

**Note:**

**This paragraph applies to the three options of installation indicated in this manual.**

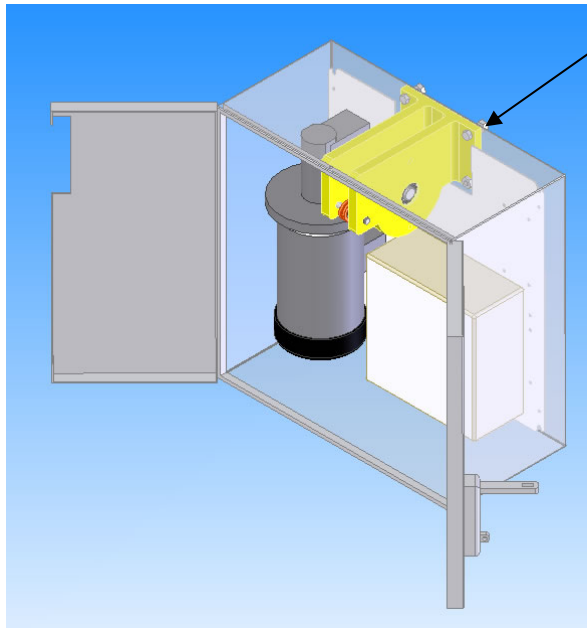

The four bolts used to mount the Motor assembly to the enclosure are removed. The top 2 bolts and nuts will be re-used when mounting the Controller & Motor Drive to the Bracket. The 2 bottom bolts are replaced by the studs on the bracket and the nuts are re-used

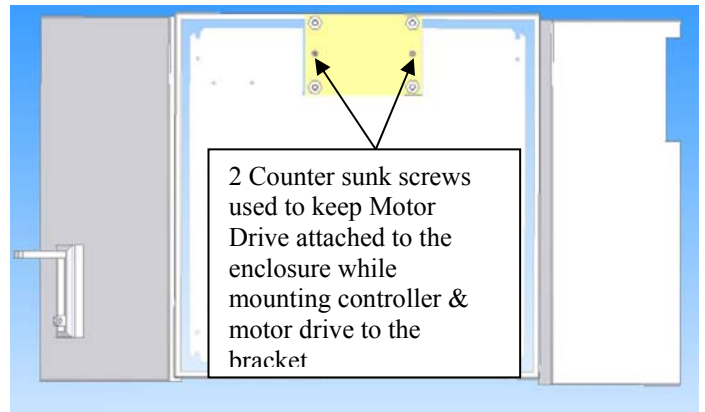

2 Counter sunk screws used to keep Motor Drive attached to the enclosure while mounting controller & motor drive to the bracket

**Option 1) Typical A-Frame installation:**

- Bolt the Motor Drive Assembly to the A-Frame using supplied bolts, washers and nuts.



A Frame Mounting Plate

**Optional**  
Custom bracket required for installing the Motor Drive



Studs used to facilitate the installation of the Controller & Motor Drive to the Bracket

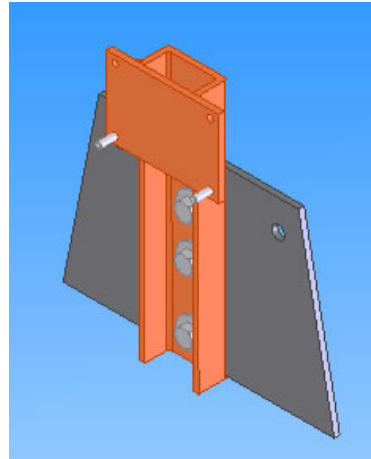
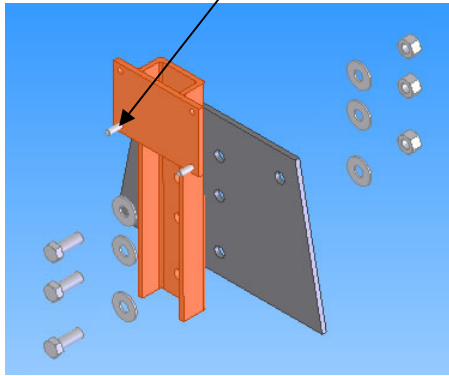

*Tighten the 3 supplied bolts as shown*

a) Use the 2 Studs to locate the Controller & Motor Drive Assembly in position

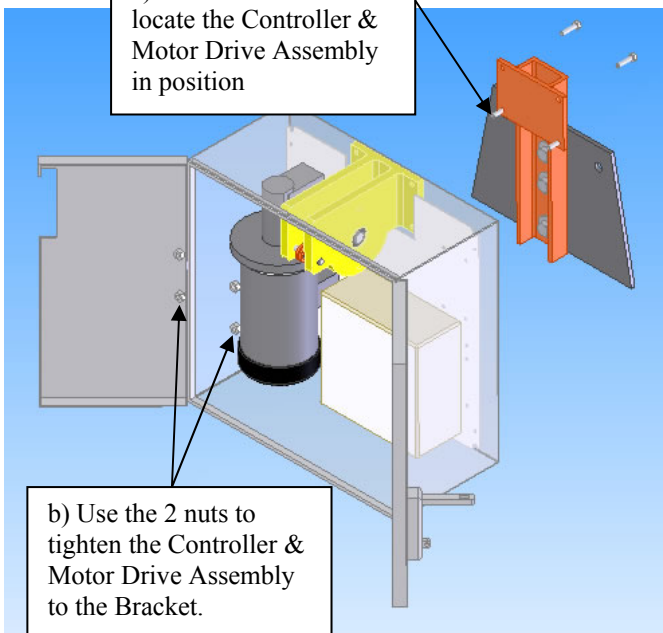

b) Use the 2 nuts to tighten the Controller & Motor Drive Assembly to the Bracket.

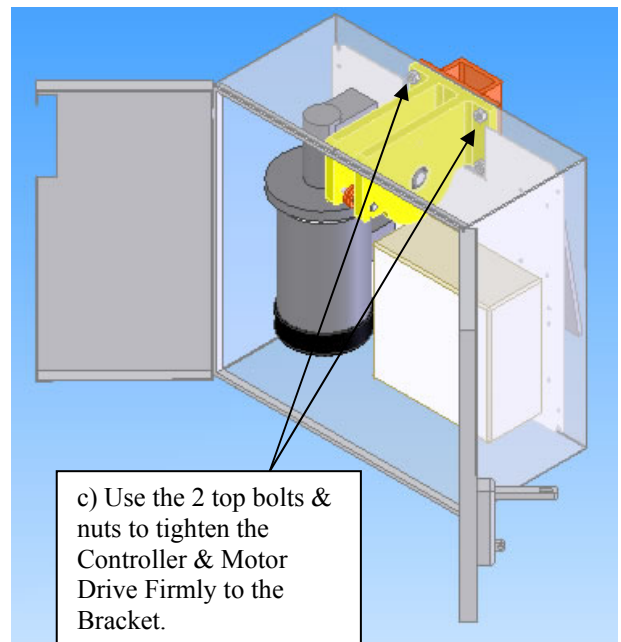

c) Use the 2 top bolts & nuts to tighten the Controller & Motor Drive Firmly to the Bracket.

Option 2) Typical installation to an existing HS Post Head:

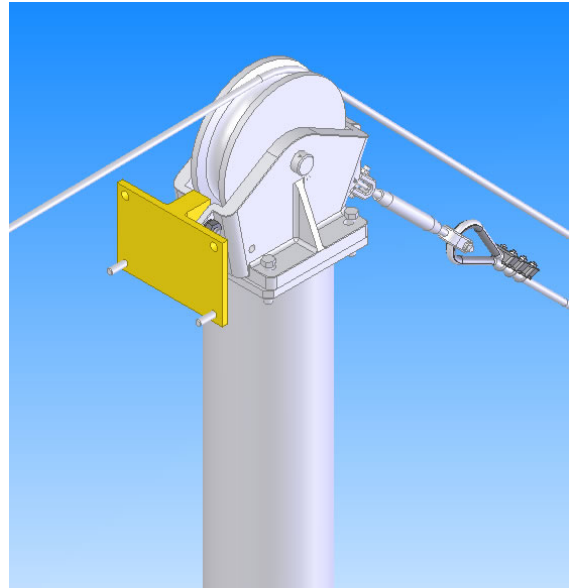
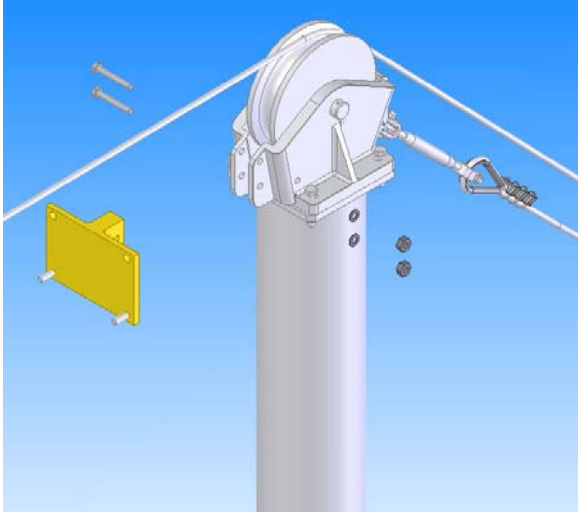

*Tighten the 2 supplied bolts as shown*

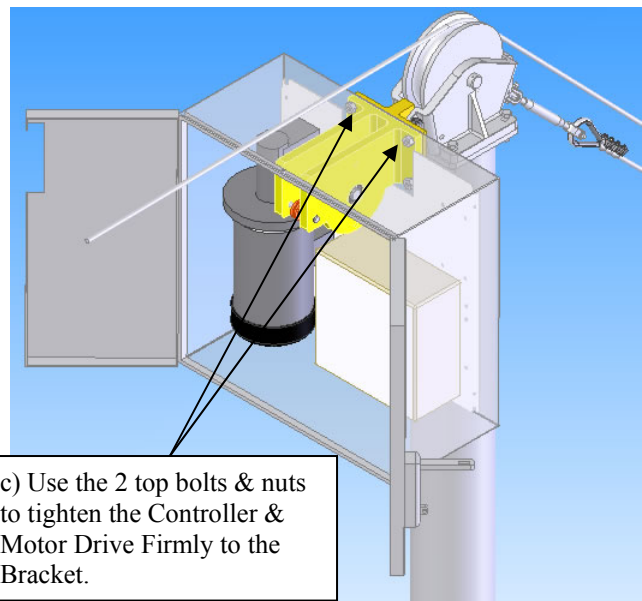
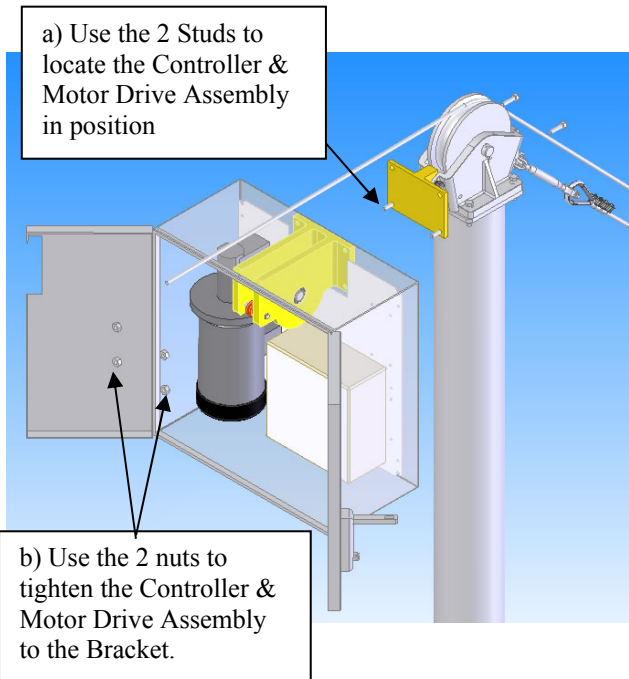

Option 3) Typical installation to a new HS Post Head:

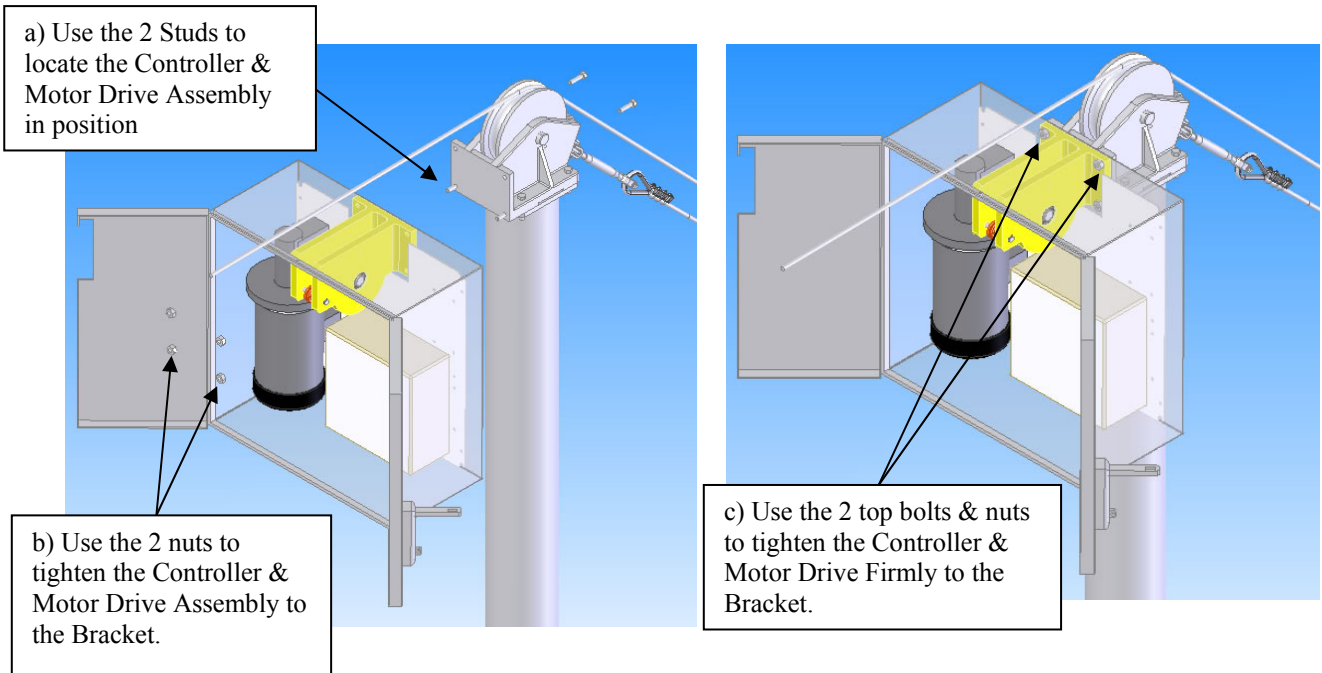

### 3.3 Installing the Far Side

Typical Far Side Installation for an A-frame:

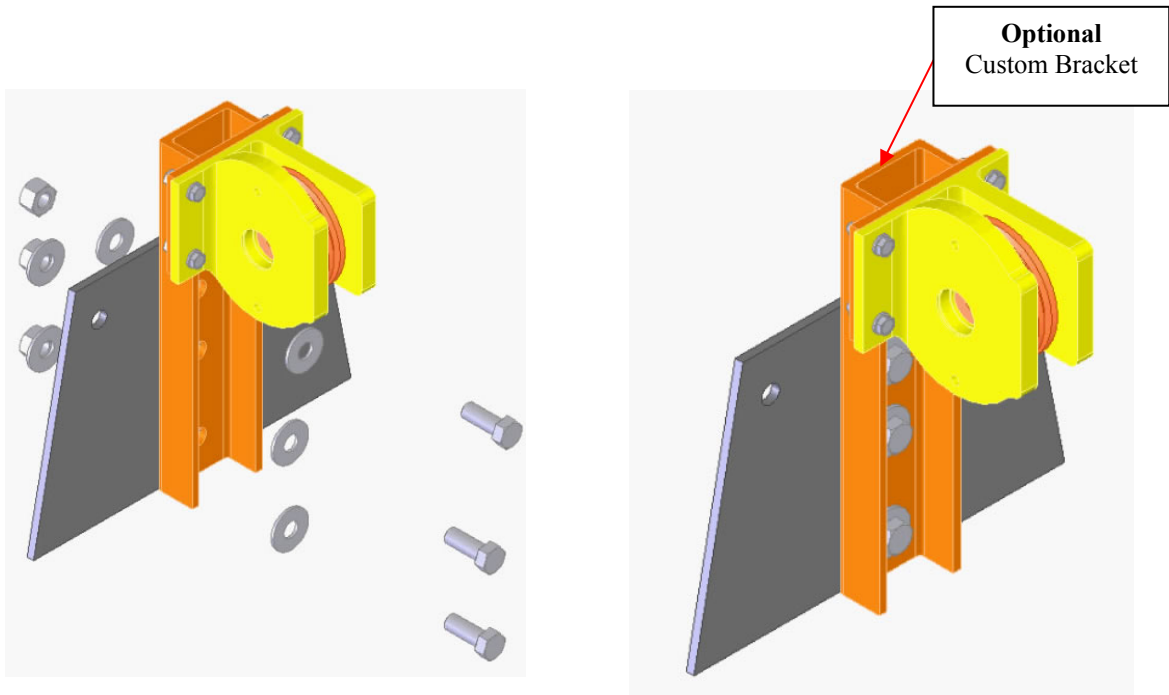

*Tighten the supplied bolts as shown*



Typical Far Side Installation to an existing HS Head:

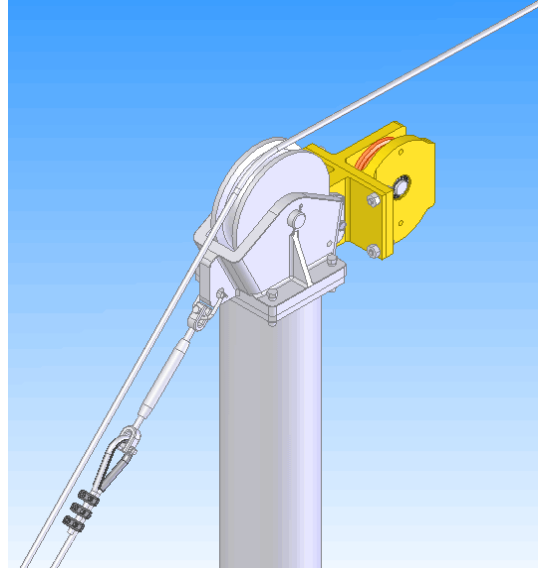
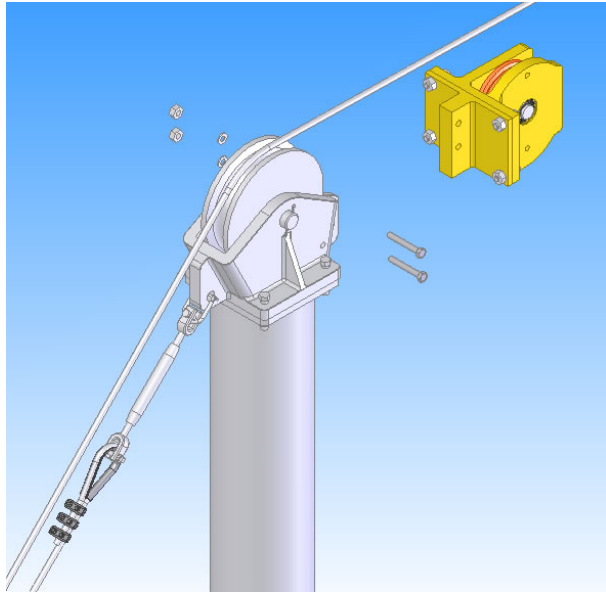

*Tighten the supplied bolts as shown*

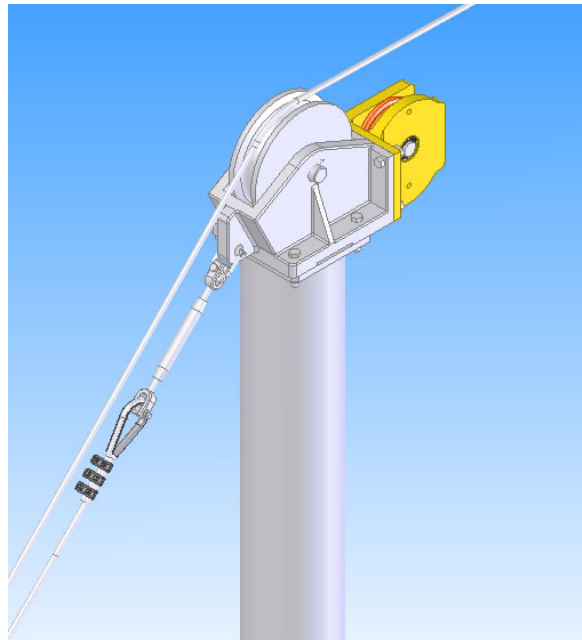
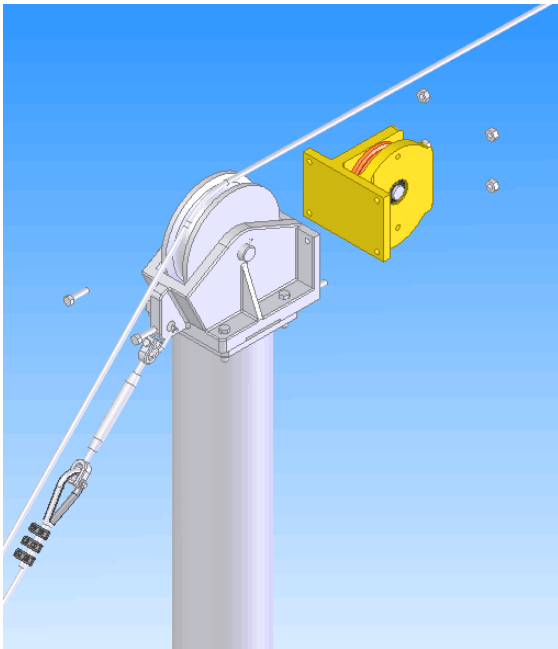

*Tighten the supplied bolts and Nuts as shown*

### 3.4 Installing the Traveller Block

#### Traveller Block Installation:

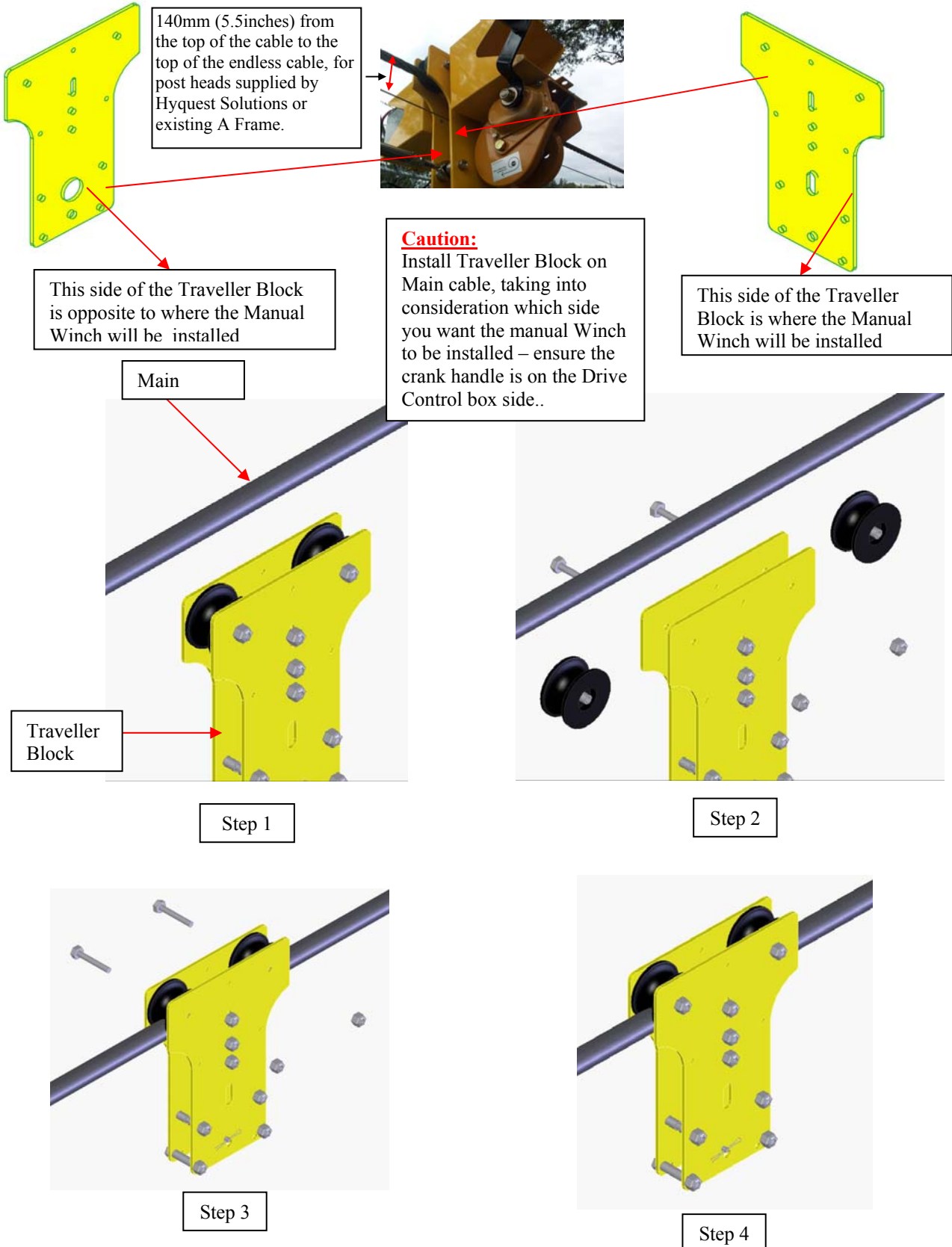

Battery Mounting Box Installation:

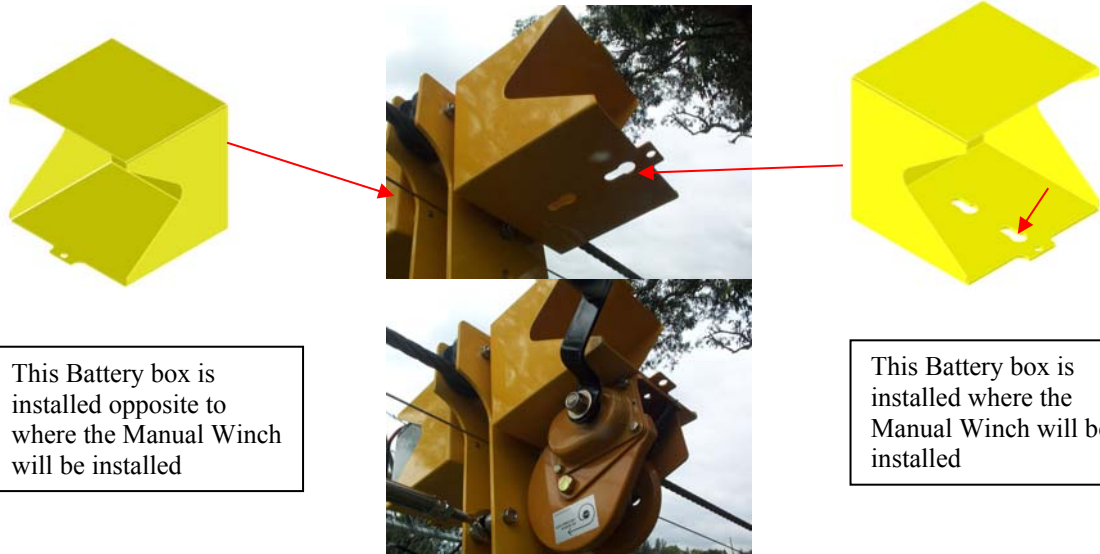

This Battery box is installed opposite to where the Manual Winch will be installed

This Battery box is installed where the Manual Winch will be installed

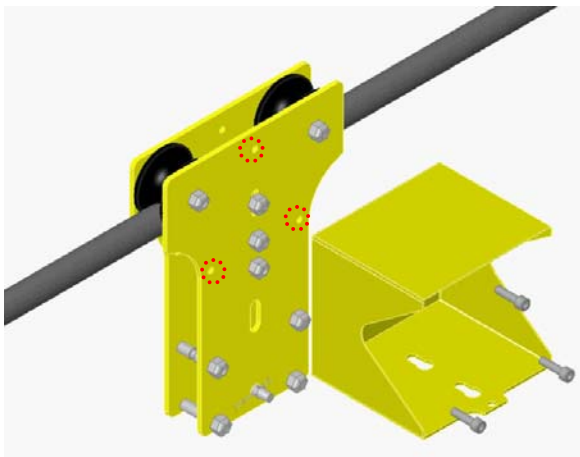

Step 1

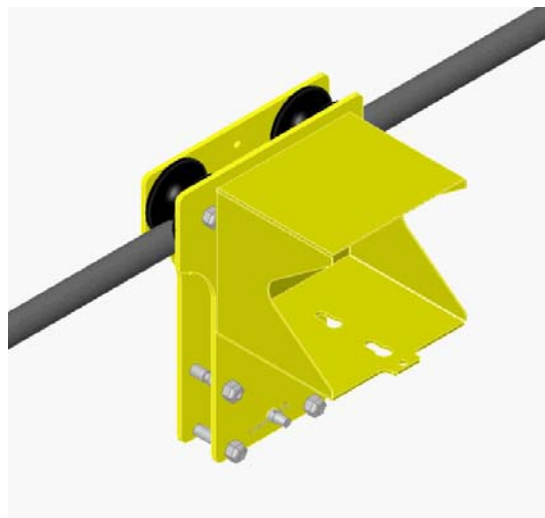

Step 2

**Note:**  
The same method is used to mount the battery box on the opposite side of the traveller block

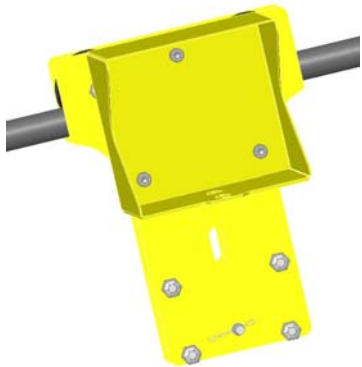

### 3.5 Installing the Traversing Cable

#### Traversing Cable Installation:

Please note the traversing cable is not a part of the Hornet / Hornet Plus standard kit, but it can be ordered separately from Hyquest Solutions.

**Caution:**

Do not cut the traversing cable even though you know the distance required. The cable is cut at the final step which will be indicated later in this manual.

#### Step 1: From the reel to the far side

Run the Traversing Cable from the Reel to the Far Side Post.

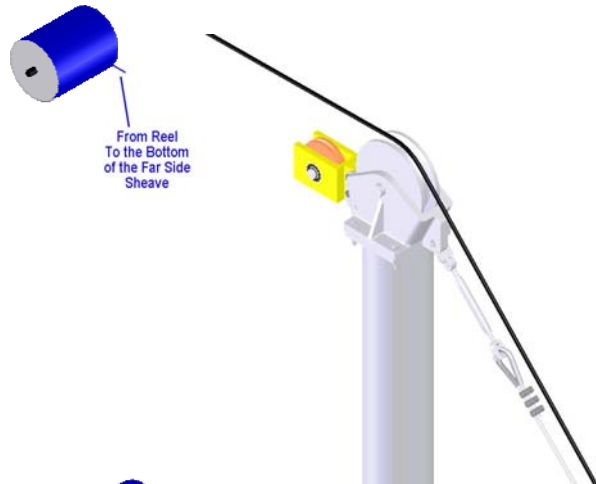

Wrap the Cable around the Return sheave from underneath, around the top and out.

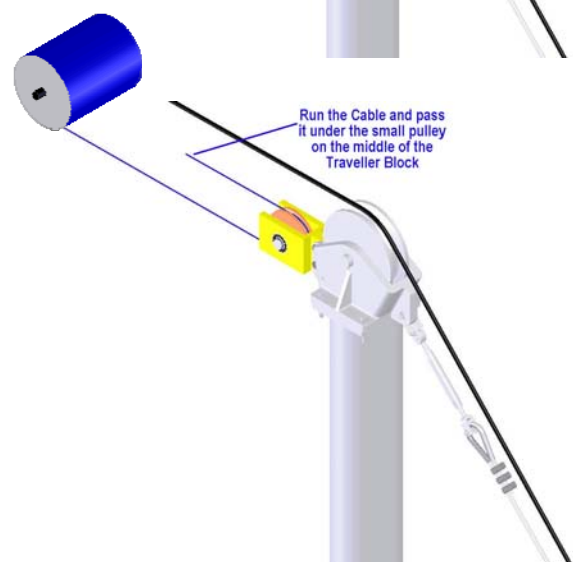
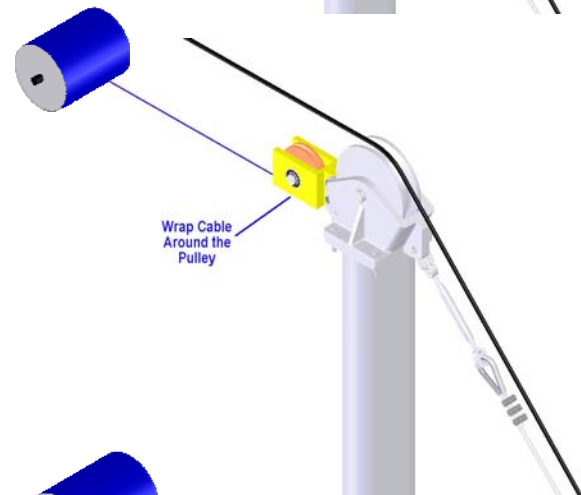

## Step 2: From far side to Traveller Block

Run the end cable back to the operating side and pass it through the Traveller Block beneath the Guide pulley as shown.

**Please Note:** The distance between the main cable and the top of the endless cable should be approximately 140mm

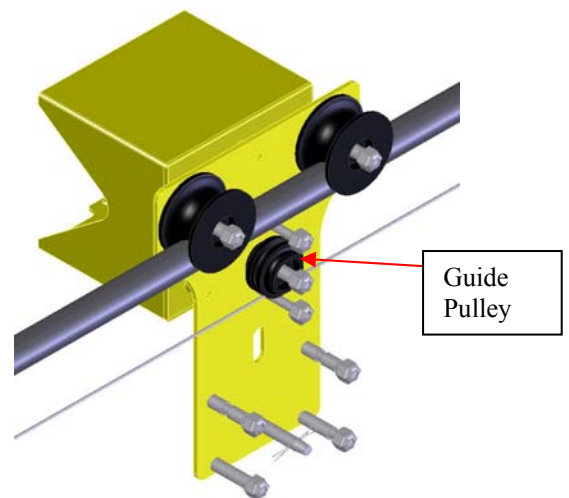
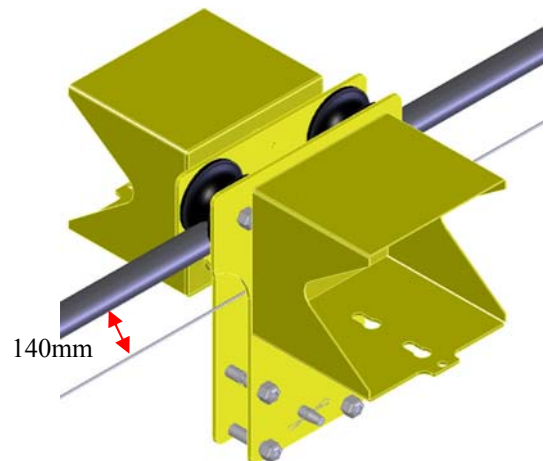
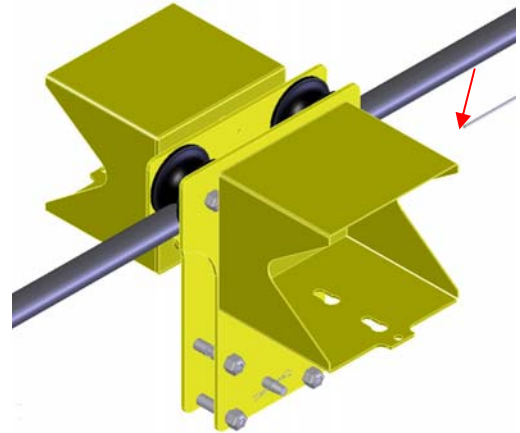

### Step 3: From Traveller Block to the Operating Side (Double Wrap)

Feed the cable from the top



Keep running the cable till you get to the operating side. Feed the cable from the top as shown.



Cable Going to the top Operating Side

(a)

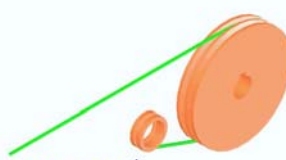

Wrap the cable around the Guide Pulley

(b)

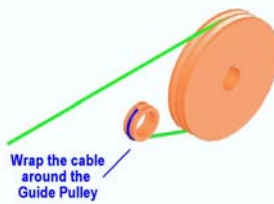

Wrap the cable around the Guide Pulley

(c)

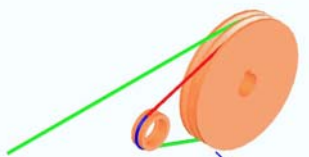

(d)

Wrap the cable around the second Groove

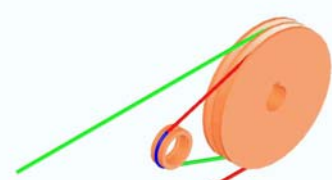

(e)

This side of the cable is attached to the Traveller Block using a Turnbuckle

### Step 4: Fitting the Turnbuckle to the end of the cable

First the two supplied swages through the cable.

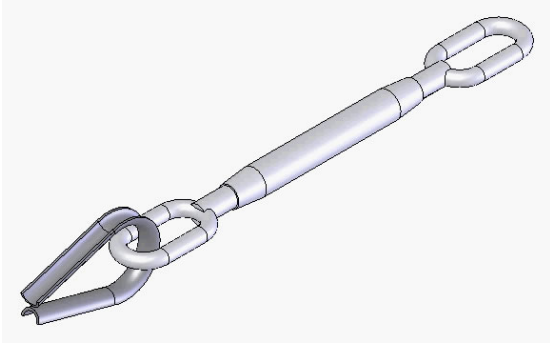

Hook the Thimble to the end of the Turnbuckle as shown

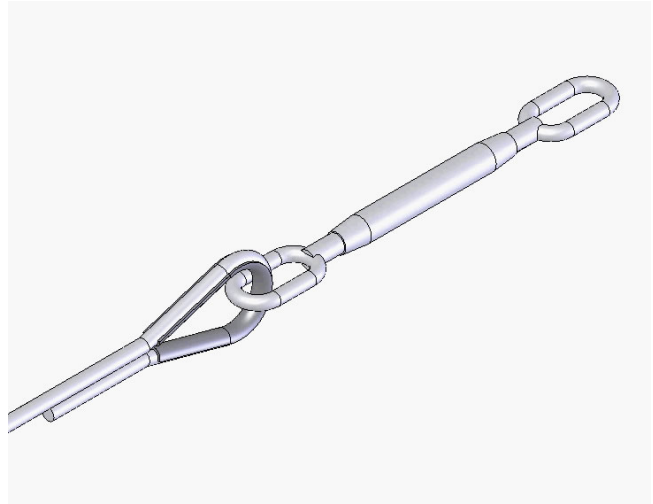

Loop the end of the cable around the Thimble as shown



Slide the swage over the looped cable and crimp it

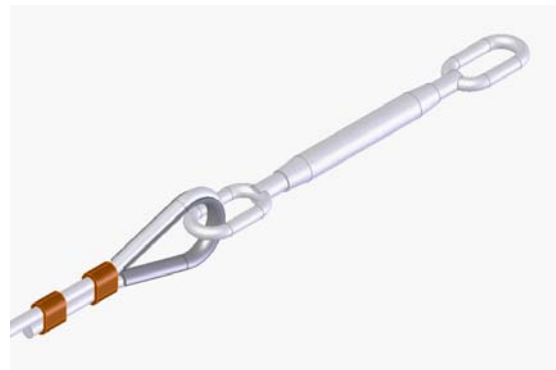

Minimum 2 x Swages are required

**Note:**

***Ensure that the Turnbuckles are loose to allow for cable tensioning later on.***

**Step 5: Fitting the Turnbuckle to the Traveller Block**

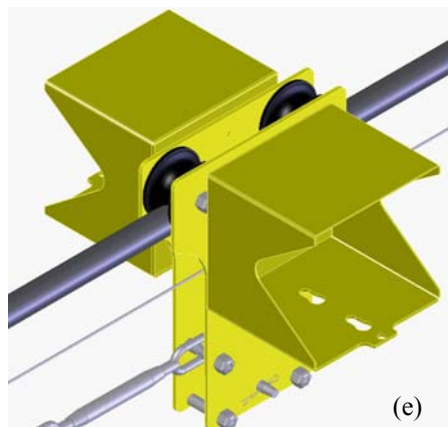
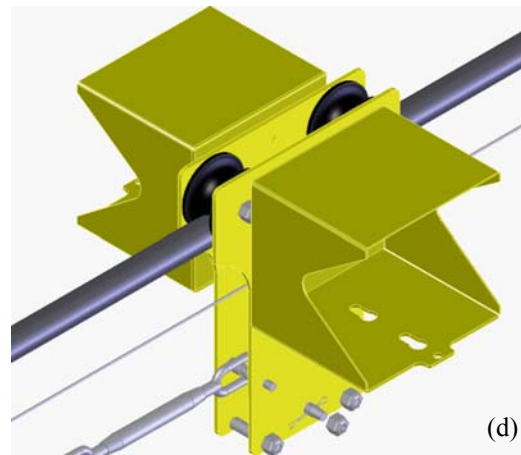
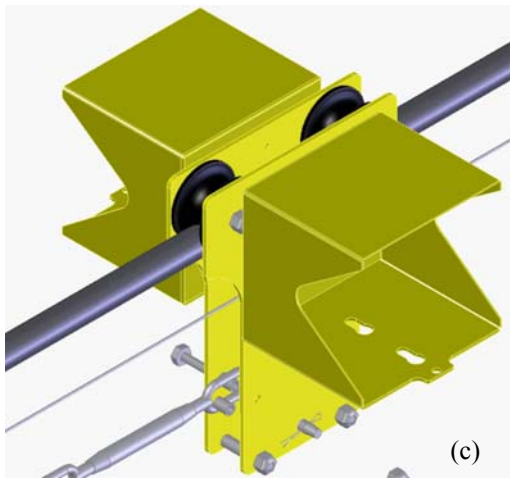
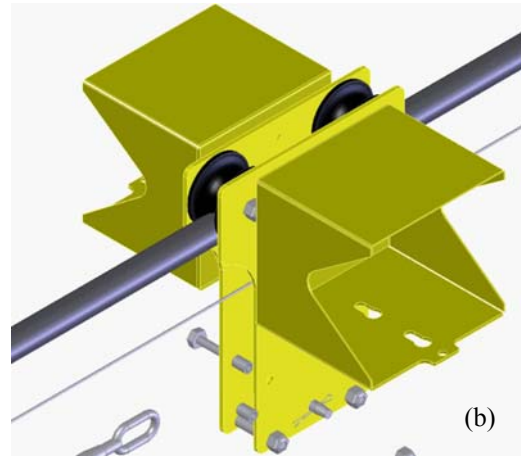
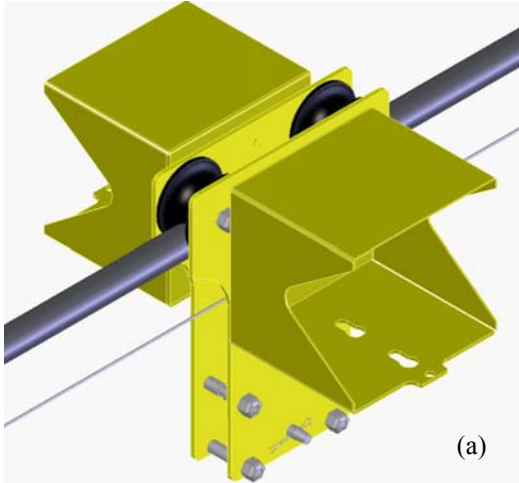



**Step 6: Fitting the Turnbuckle to the other side of the Traveller Block**

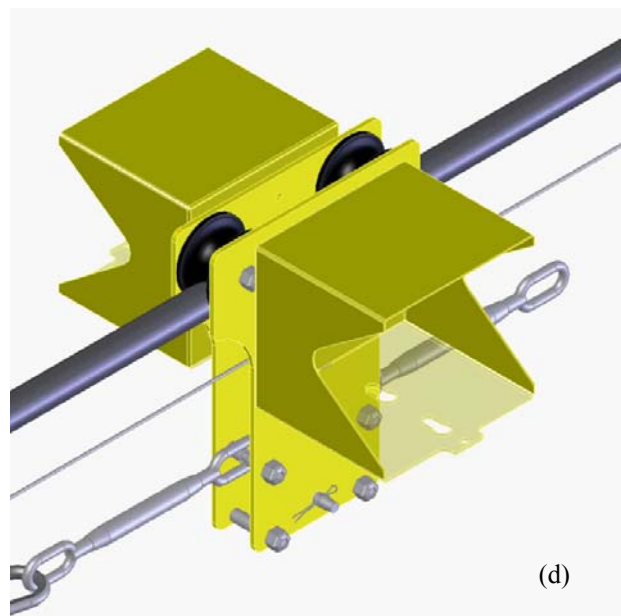
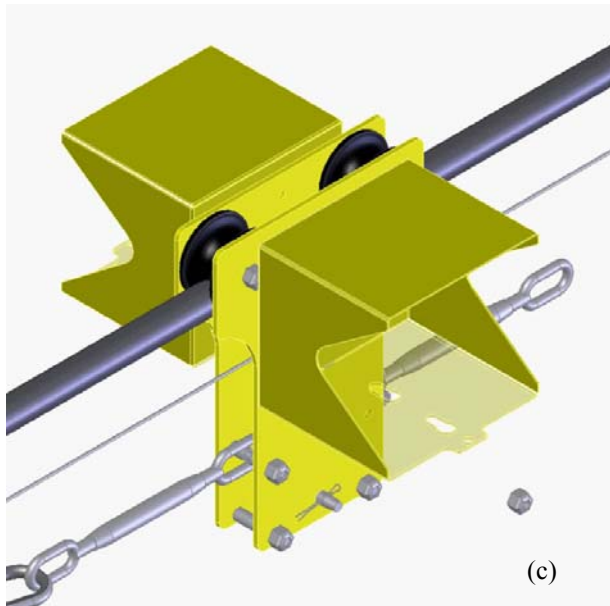
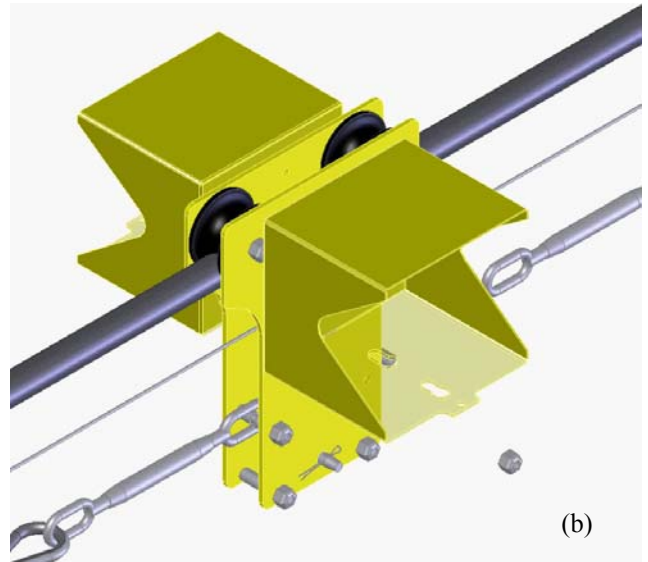
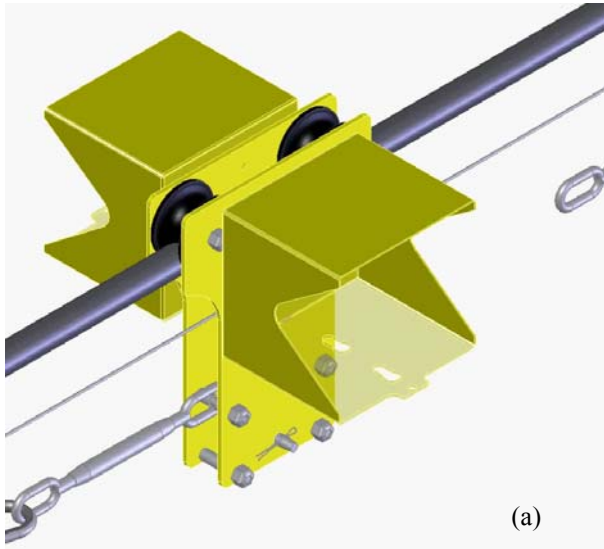

## Step 7: Fitting the other end of the Traversing cable to the Turnbuckle

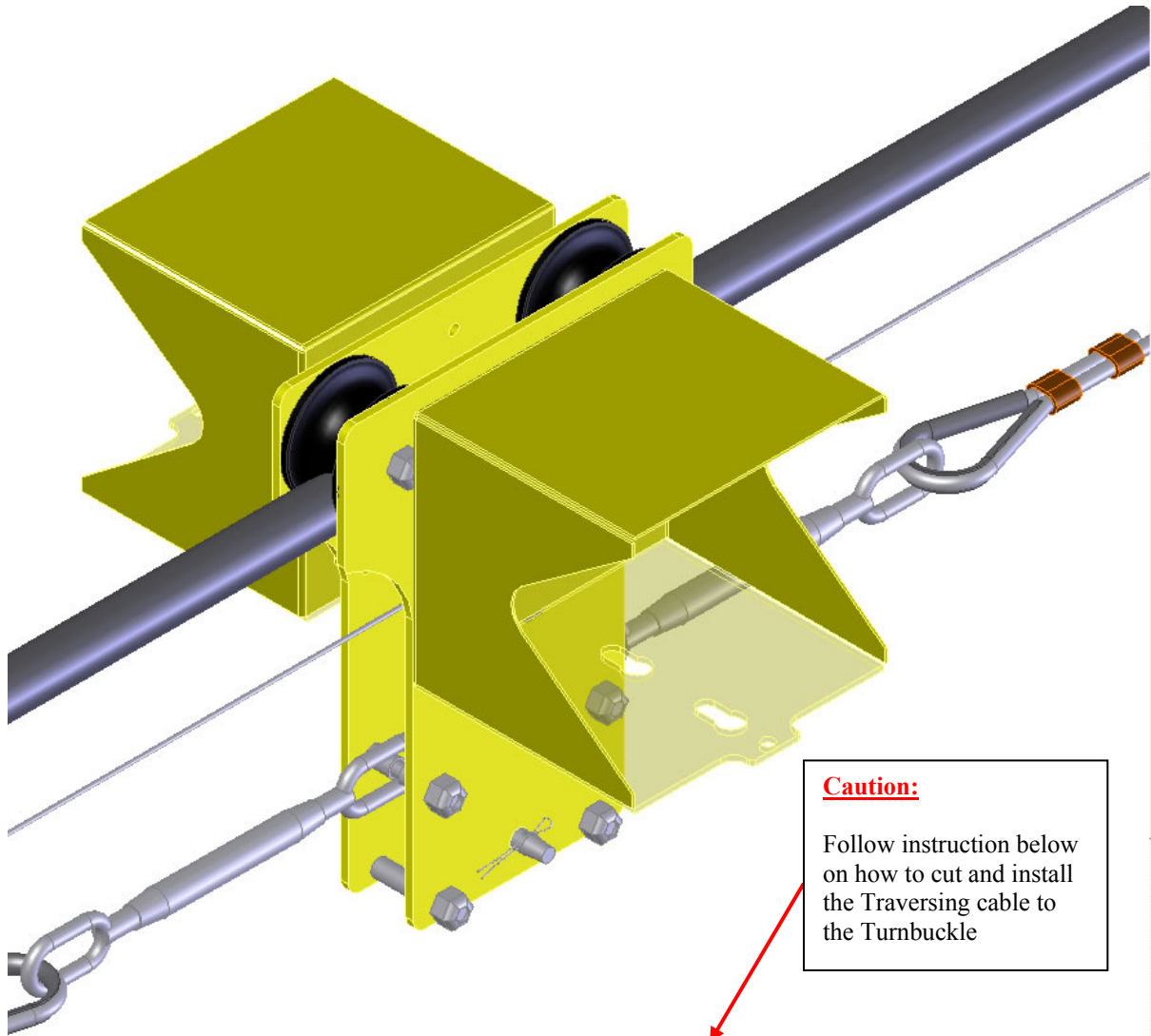

- Pull the excess cable across the span until you achieve reasonable sag below the main cable.
- Cut the wire with one metre in excess, to allow for tensioning and adjustment.
- Feed the 2 supplied swages through the cable
- Attach the cable to the turnbuckle but do not crimp yet
- Adjust the traversing cable to achieve the correct tension using the Turnbuckles.
- Gripping the 1 metre tail, tension cable up as much as possible and crimp it.
- Cut any excess wire that is not required.

### 3.6 Attaching the Batteries and the Winch to the Traveller Block

Install the first battery opposite to the winch side and in place using the hinged pin



Hinged Pin

Install the manual winch to the bottom of the battery box as shown



Slots for the Manual Winch

Install the second battery in place and use the hinge pin to lock both the battery and the winch in place



Locking pin used to hold battery and winch in place

### 3.7 Installing the Hoist



## Warning

- 1- Before installing the Hoist inspect the manual winch cable and ensure the cable wires are intact and show no signs of fraying.
- 2- If the cable is frayed, do not use the winch as it is not safe to do so.
- 3- Use the manual handle supplied with the winch, **DO NOT USE ANY POWER TOOLS** to operate the manual winch as excessive torque generated from these power tools could damage the cable, manual winch and detach the hoist from its location.
- 4- When lifting the hoist ensure no one is standing directly under the hoist for safety reasons.

- Release the cable on the manual winch and feed it through the Traveller Block plate above the roller and down to the hoist as shown
- **Note: The manual winch is used to avoid lifting the hoist**

- Straighten the Antenna on the Hoist as shown

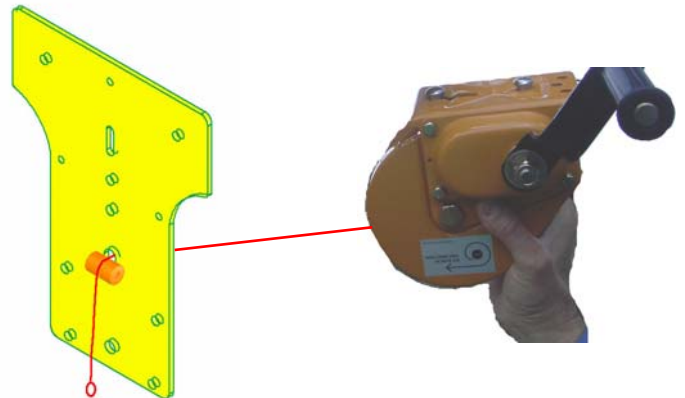

Cable released from the manual winch down to the hoist.



Hook the cable to the hoist as shown





Lift the Hoist using the manual winch



 **Warning**

5- As the hoist engages inside the traveler block, a small force should be exerted on the manual handle of the winch so that the holes align sufficiently to allow the pin to be inserted. Please note, excessive force exertion is not required as this may damage the hook, cable and winch.



Remove the pin and keep lifting the Hoist till it coincides with the traveller block



Replace the pin



Replace the R-pin

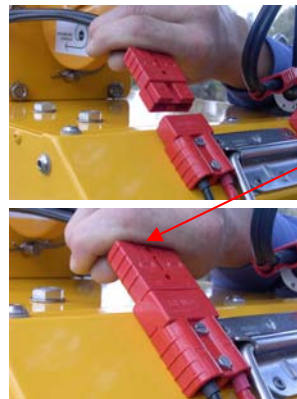

Connect the batteries to the Hoist as shown

### 3.8 Fitting the Drive Control Interlock Box to the Main Cable



The Drive Control Interlock Box also contains an Inclinometer to measure the angle of the main cable which will allow the true horizontal distance across the river to be automatically calculated.



When tightening the knobs, make sure that the cable is in contact with the two lower studs (so that the box is aligned with the cable). This allows the internal inclinometer to measure the cable angle.

### 3.9 Attaching the Current Meter and Gauging Weight to the Hoist

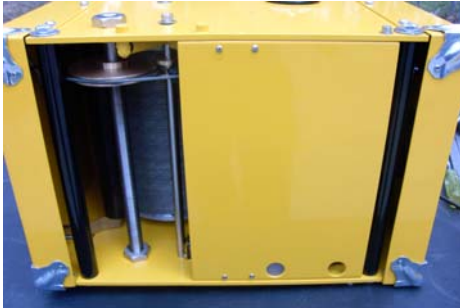

Open the Cover at the bottom of the Hoist



Turn the Hoist Power On

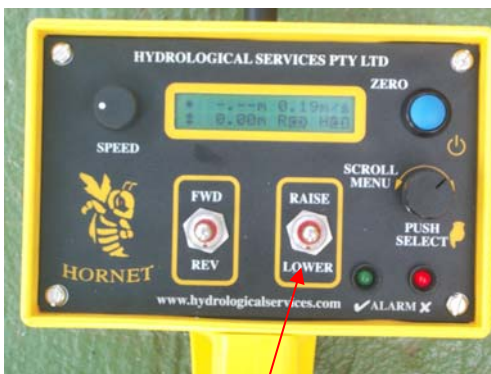

Use Lower to release the C1 connector



Release the C1 Connector from the spring



Lower the cable to attach the C1 Connector to the Hanger Bar

## 4 Operation

### 4.1 Initial Power Up

Once the system is assembled as described in section 3, simply apply power to the Drive Controller (either from the mains or from a small 1000Watt petrol generator). Press the button under the Hoist to turn it on. This button is a push on / push off type - the blue LED under the hoist indicates power is on. Press and hold the Power button on the Remote Control and the LCD will come on. The red LED on the Remote Control should turn off when communications is established. The green LED will flash as the Remote Control communicates with the Hoist and Drive Controller.

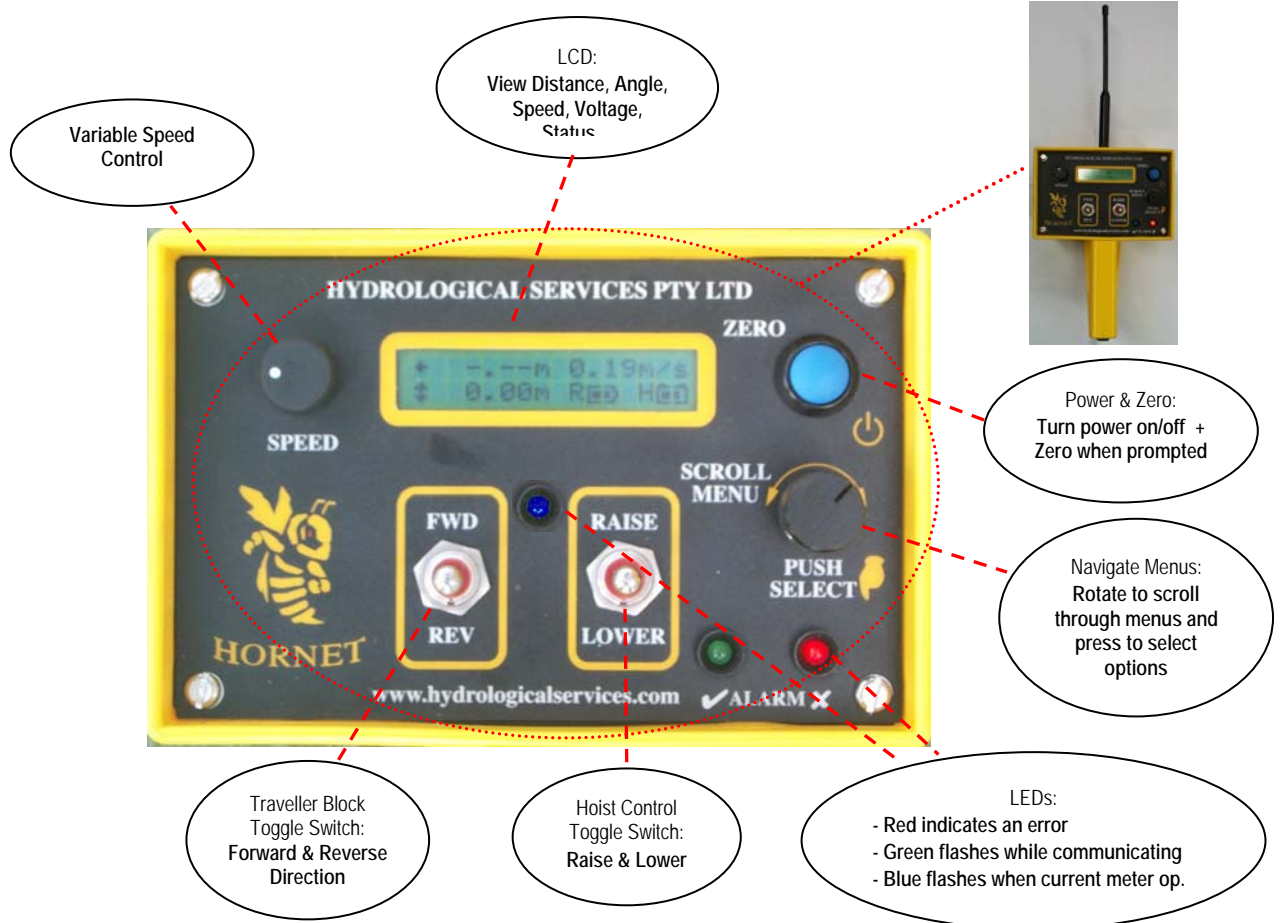

The Remote Control is the brains of the system. Radio communication messages are initiated from the Remote Control to both the Hoist and the Drive Controller.

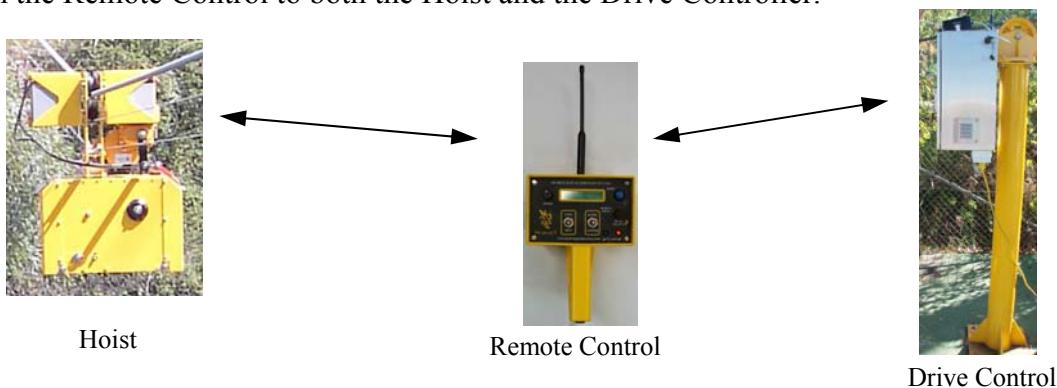



## 4.2 Brief Description of Controls

### Power + Zero

Press and hold the blue button to turn on the Remote Control (wait until the LCD comes on) When the Remote Control is “on”, press and hold the blue button to turn off the Remote Control. When a zero is required, the user will be prompted to press the “zero” button with a “Z” and a down arrow symbol on the lower RHS of the LCD.



### Speed

The speed control knob sets the drive motor speed that controls the carriage movement. When using an ADCP it is important to traverse the water at a constant speed. (The speed is displayed on the main menu in either m/s or ft/s, depending on the units selected in the Remote... menu.)



### Fwd / Rev

The Fwd / Rev toggle switch controls the carriage movement via radio communications. If there is any problem, the cause will be displayed on the LCD while the switch is being operated.

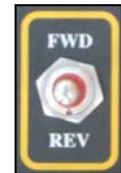

### Raise / Lower

The Raise / Lower toggle switch controls the hoist via radio communications. If there is any problem, the cause will be displayed on the LCD while the switch is being operated.

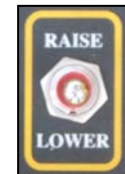

### Red, Green and Blue LED

When the red Status LED is on, it indicates there is a problem. This could be due to Hoist or Drive Control communications, Hoist battery is low, Remote Control Battery is low, or the Drive Control Interlock (proximity and inclinometer sensors) is not plugged in properly.



The green LED flashes whenever comms is successful to either the Hoist or the Drive Controller.

The blue LED flashes as the current meter signal is operating – and comes on steady if the “ground feeler detect” shorts the current meter signal. (See Appendix E)

### Menu Navigation

The menu navigation is performed by rotating the “Scroll Menu” knob clockwise and anticlockwise. Pressing the same knob allows the operator to select options etc. See the section on navigating the menus for a full description.



### LCD + Backlight

The LCD has backlighting, which can be always OFF, always ON, or on for several seconds when anything is touched. The LCD backlighting option can be changed in the “Remote...”

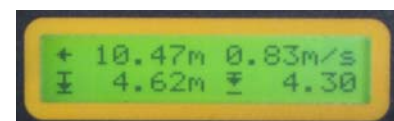

menu. When communicating with a standard Hornet, all reference to vertical distance, airline, wetline, corrected depth, hoist cable angle and current meter count is automatically removed from the Remote Control LCD menus – this is because these features are only present on a Hornet Plus.

### Sounder

The remote control has an inbuilt sounder, which beeps when the current meter input is pulsing. The sounder function can be turned off in the “Remote...” menu.

### Current Meter Input and Output

A current meter can be plugged into the Hoist, and the contact closure information is transmitted to the remote control – which has an output that can be connected to your favorite Current Meter Counter. The current meter input on the Hoist accepts both Mag Head and Cats Whisker type meter inputs and performs signal processor filtering on the input to ensure that clean data is transmitted to the remote control unit. The type of meter is selectable from the “Hoist...” menu.



### Operating Frequency

The Hornet / Hornet Plus components communicate to each other in the 915MHz band which is the ISM (Industrial, Scientific and Medical) license free band. There are 26 channels available, which can be user selected at any time. The frequencies used are 902.5MHz through to 914.5MHz in the USA (with a 1MHz channel spacing) and 915.5MHz to 927.5 MHz in Australia (with a 1MHz channel spacing). The only requirement when changing frequencies, is that all 3 components (Remote Control, Hoist, Drive Control) must be turned on and communicating at the same time. The transmitter power is +15dBm, which is equivalent to only 32mW. This provides a line of sight range of about 1km.



### NiMh Battery Charging

The handle of the Remote Control has provision for charging the internal NiMh batteries that power the Remote Control. A mains power plug-pack is provided, but a vehicle cigarette lighter adapter could also be used. The voltage required is 12VDC with a capacity of 1A. (A 9VDC to 18VDC plug-pack can be used.) The connector is a DC Power 2.1mm connector with center pin +ve. (The charging socket is polarity protected.) If the Remote Control is off when the charging plug is inserted, the Remote Control will automatically turn on, and indicate it is charging by scrolling the Remote battery indicator. The batteries will be initially fast charged at about 500mA, and when fully charged drop back to a trickle charge – so there is no problem with leaving it plugged in for extended periods.



In an **emergency** you can use 3 x AA Alkaline batteries to power the Remote Control. Simply remove the 4 screws that secure the front panel of the Remote Control, then remove the lower screw on the strap over the 3 batteries and rotate the strap out of the way. Replace the 3 x NiMh batteries with 3 x alkaline batteries and re-assemble the Remote Control.

**NOTE : Do not attempt to charge while alkaline batteries are installed !!**

### 4.3 Menu Operation

As previously stated, the controller menu is navigated by rotating and pressing the “Scroll Menu” knob. The navigation structure is shown on the back of the Remote Control as a handy reference – and duplicated here.



The two main menus show the most used information. Pressing the scroll menu knob while in these menus allow zero functions to be performed. Stepping into the More... menu allows data specific to the Hoist, Drive Control, Remote Control and Alarms to be displayed.

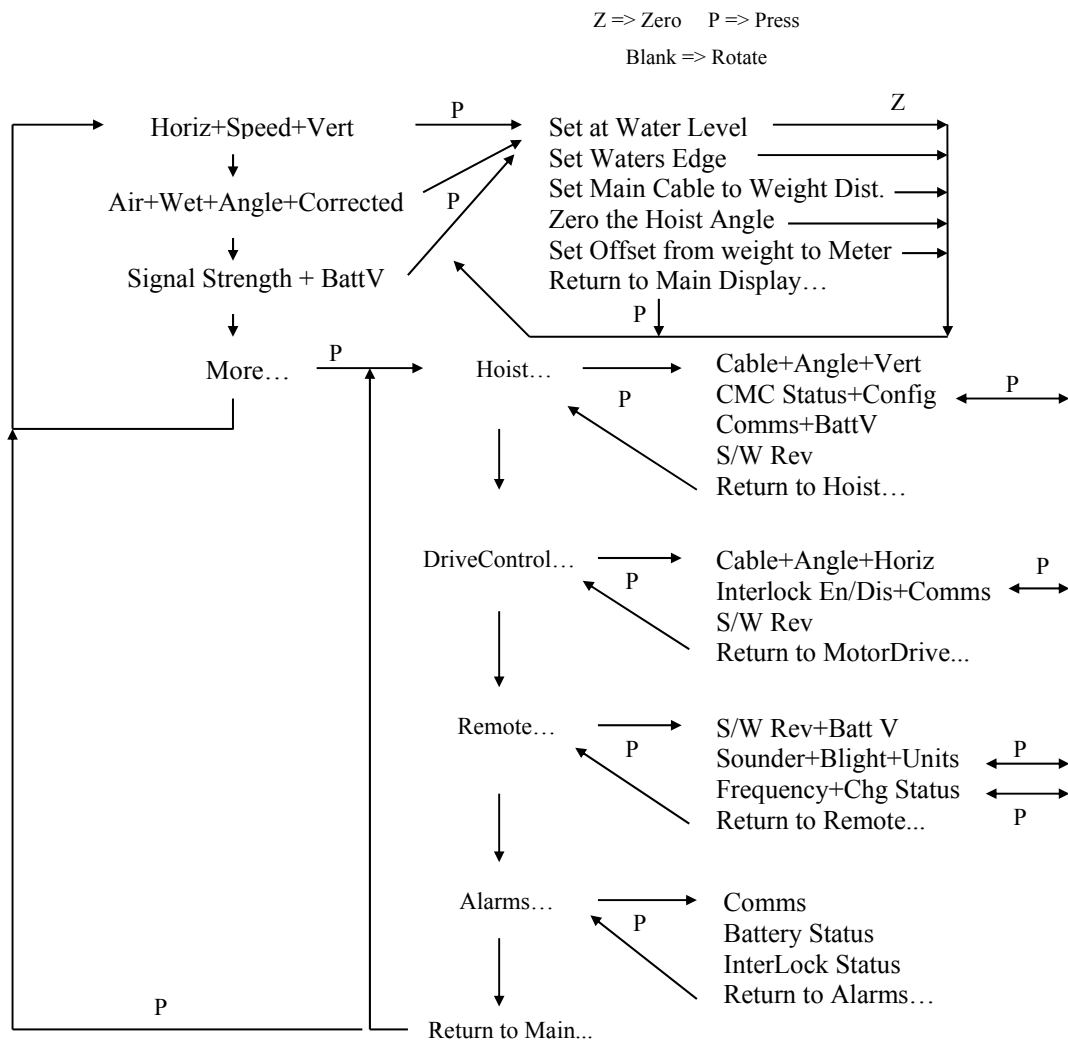

Each menu display item will now be described in detail.

Note that if a measurement cannot be displayed due to a comms error, the data will be displayed as “ -.- - “. The Drive Control makes all horizontal measurements and respective angles – and the Hoist makes all vertical measurements and respective angles.

### 4.3.1 Main Display

The top line on the display shows the horizontal distance traversed from the Waters Edge (note the arrow pointing horizontally), and the Drive Control Speed which is set with the Speed Control knob. The bottom line shows the vertical water depth to the bottom of the weight (corrected depth – note the arrow pointing vertically that touches the horizontal line at the bottom) and the depth to the center of the current meter (note the arrow pointing vertically that doesn't quite touch the horizontal line at the bottom) – (these only appear on a Hornet Plus).

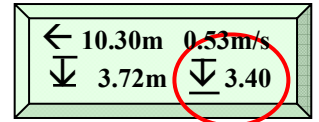

**IMPORTANT :** Use the “depth to the current meter” when recording water velocity measurements for your gauging.

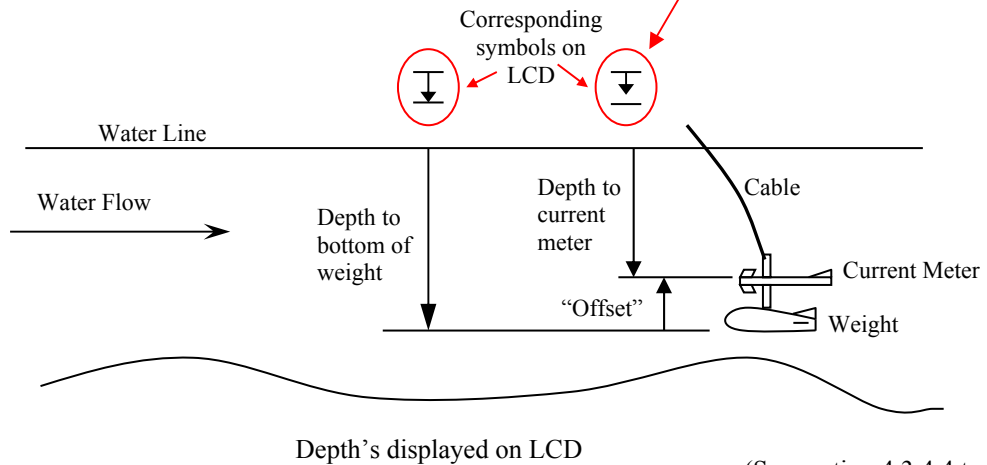
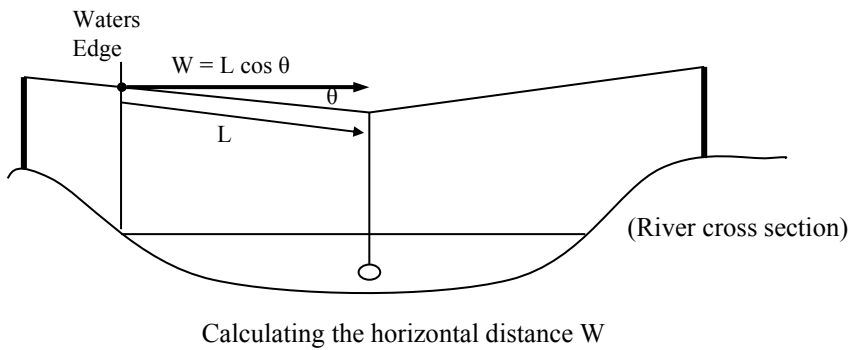

(See section 4.3.4.4 to see how the “Offset” is set.)

Rotate the Menu Scroll knob to move to the Air/Wetline or Sig/BattV or More.. display. Press the Menu Scroll knob to select commonly used Zero functions.

### 4.3.2 Airline / Wetline / Corrected Depth Display (Hornet Plus only)

The top line shows the Airline (that is the length of cable that is in the air) and the Wetline (that is the length of cable that is under the water). The bottom line shows the corrected depth (that is the vertical depth under the water) and the cable angle. Note that these measurements are dynamic – they are continuously calculated. If the angle changes, then the airline, wetline and corrected depth are all recalculated. (Note that the corrected depth takes into account the cable curve under the water.) All measurements are to the bottom of the weight.

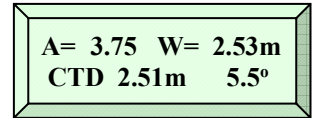
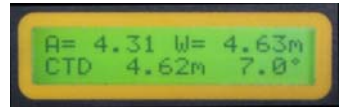

**NOTE** : The Corrected Depth is calculated in accordance with the USGS “Measurement and Computation of Stream Flow Vol 1” Water Supply Paper 2175

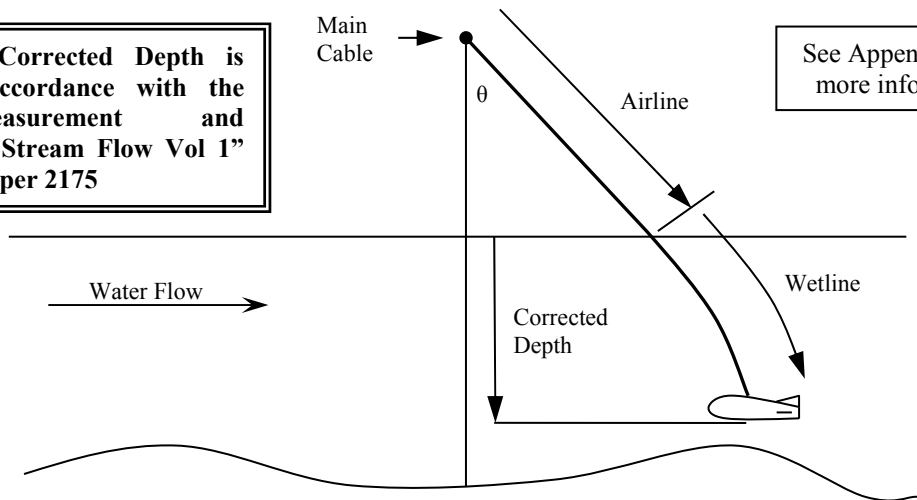

See Appendix D for more information

Calculating the corrected depth

Rotate the Menu Scroll knob to move to the Main or Sig/BattV or More.. display. Press the Menu Scroll knob to select commonly used Zero functions.

### 4.3.3 Signal Strength and Battery Voltage

The top line shows the Hoist RF signal strength and the Hoist battery voltage, and the bottom line shows the Motor Drive RF signal strength and the Remote Control battery voltage. (This is a new feature in Remote Control S/W Rev 1.6 and above)



The RF signal strength is represented as a triangle that gets larger as the signal increases (in a similar way as your mobile phone). Since you are usually very close to the Motor Drive, the RF signal strength should usually be very high. As the Hoist moves away from you, as it traverses the river, the corresponding RF signal strength will reduce.

The Hoist battery symbol looks like a “terminal style” battery and the Remote Control battery looks like an “AA style” battery. The symbols become less “filled in” as the battery capacity depletes - the voltage is also displayed.

Rotate the Menu Scroll knob to move to the Main or Air/Wetline or More.. display. Press the Menu Scroll knob to select commonly used Zero functions.

### 4.3.4 Zero Functions

The zero functions are selected by pressing the Menu Scroll knob while in the Main Display or the Airline / Wetline Display. These allow reference points to be entered for horizontal and vertical measurements. Rotate the Menu Scroll knob to step through the various functions.

During a gauging session the “Zeros” would be performed in the following order :

1. Hang the weight on the Hoist and “Zero the Hoist Angle”
2. Measure the distance from the Hoist to the bottom of the Weight – and “Set Main Cable to Weight Distance”
3. Measure the distance from the bottom of the Weight back up to the center line of the current meter - and “Set Offset from Weight to Meter”
4. Position the carriage and then “Set the Waters Edge”.
5. Position the weight just above the water and “Set at Water Level”

#### 4.3.4.1 Set at Water Level (Hornet Plus Only)

This zero function appears first because it is the most commonly used when taking measurements at each vertical. Position the weight so that it is just above the water level. Note the Z on the right hand side of the display is to prompt you to press the blue Zero button to zero the water level. Any measurement below this level will be Wetline or Corrected depth, and anything above this point will be Airline. (See the sketch on the previous page.)

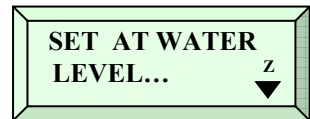

#### 4.3.4.2 Set Waters Edge (Hornet and Hornet Plus)

Position the weight so that it is just above the closest waters edge. Press the blue Zero button. This will zero the horizontal distance counter so the river width can be measured.

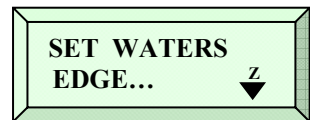

#### 4.3.4.3 Set Main Cable to Weight Distance (Hornet Plus only)

This function sets a reference point for the vertical distance measurement. Press the blue Zero button. The HoistHt 0.65m will flash – this is the distance from the main cable to the bottom of the hoist. If a carriage extension is used, this distance will be 0.95m, so

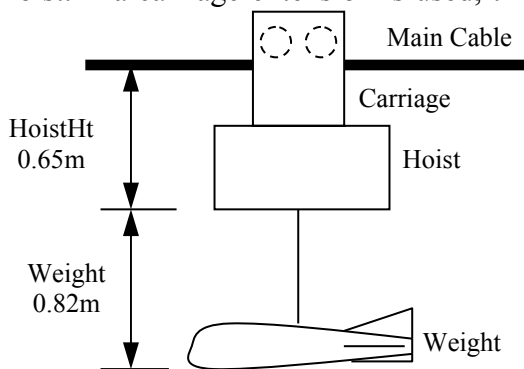

rotate the menu scroll knob to toggle between these two values. Press the menu scroll knob and the Weight 0.82m will flash – this is the distance from the bottom of the Hoist to the bottom of the Weight. Measure this distance and then rotate the menu scroll knob until the measured value is displayed – now press the menu scroll knob to complete setting the reference height

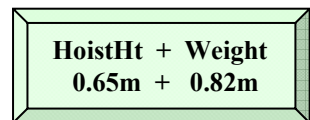
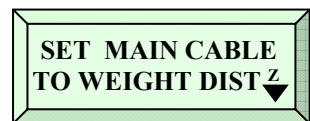

**4.3.4.4 Set Offset from Weight to Meter (Hornet Plus only)**

This function sets the offset from the bottom of the weight back up to the center of the current meter. Press the blue Zero button and the

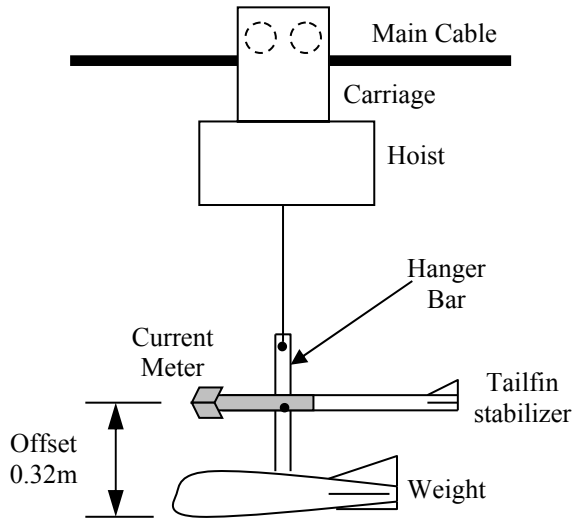

Offset 0.32m will flash – measure this distance and then rotate the menu scroll knob until the measured value is displayed – now press the menu scroll knob to complete setting the offset.

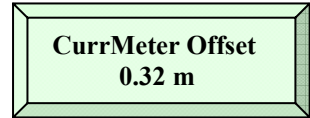

Setting this value allows the direct reading of the depth to the current meter – see section 4.3.1 to see how and where the depth to the current meter is read !!!

**4.3.4.5 Zero the Hoist Angle (Hornet Plus only)**

The size of the weight hanging from the Hoist will determine the initial angle that the Hoist settles to. After hanging the weight from the Hoist, “Zero the Hoist Angle” so that a reference point is taken. The cable angle is measured from this reference point.

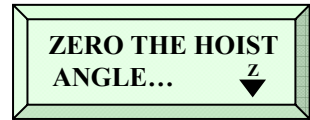

**4.3.5 More...**

This menu item is the door to Hoist... Drive Control... Remote... and Alarms... menu. Press the menu scroll knob to enter the Hoist... menu.

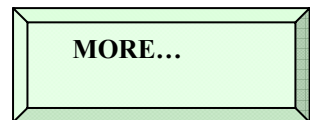

### 4.3.6 Hoist...

This menu is the entry point to view Hoist information (Cable Length, Angle, Vertical Distance, Battery Voltage, S/W Rev) and change Hoist parameters (signal processor config Mag Head / CatsWhisker or Norm / Slow operation). Rotate the menu scroll knob to step to the Drive Control... menu or press the menu scroll knob to view Hoist information.

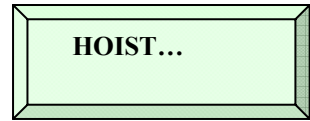

#### 4.3.6.1 Hoist Cable Length and Angle (Hornet Plus only)

The top line displays the total cable length that has been fed out, with the cable angle. (Note the special symbol that indicates an angle) The bottom line displays the corrected depth – that is the vertical depth of the weight below the water line. (Note the symbol indicating vertical depth.)

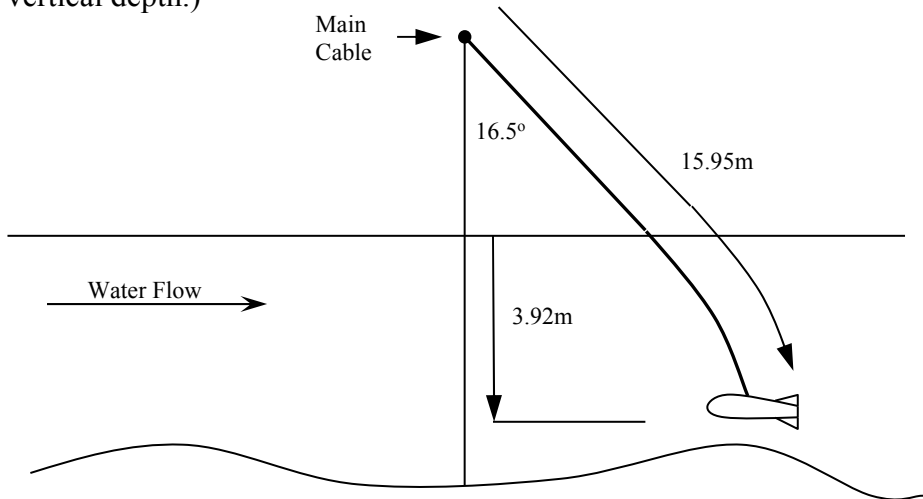
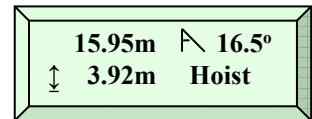

#### 4.3.6.2 Hoist CMC Signal Processor (Hornet Plus only)

The Hoist has an inbuilt Current Meter Signal Processor that is used to clean up the current meter signal. When the Hoist is raised or lowered, the signal processor is forced into a calibration which automatically compensates for water conductivity. The top line of the LCD displays the status of the CMC Signal Processor as either OK, Cal (calibrating) or Flt (faulty). The faulty condition may occur if there is a short circuit on the current meter contact input. Press the menu scroll knob and the MagHd option will flash. Rotate the menu scroll knob to select the CatsWhisker option and press the menu scroll knob again to save it. When the menu scroll knob is pressed again, the Nrm (Normal mode) option will flash. Rotate the menu scroll knob to select Slo (Slow mode) and press the menu scroll knob again to save it. The most common option is MagHd/Nrm. (See the current meter section for more details)

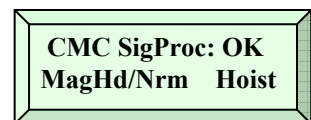



#### 4.3.6.3 Hoist Comms and Battery Voltage

The top line of the LCD displays the Hoist Comms status and the bottom line displays the Hoist battery voltage.

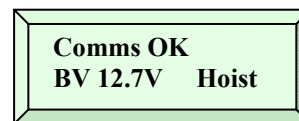

Rotate the menu scroll knob to step to the next Hoist menu.

#### 4.3.6.4 Hoist S/W Rev

The top line of the LCD displays the Hoist Software Revision. This allows us to check compatibility without opening up any equipment. A '+' after the software revision means you are communicating with a Hornet Plus hoist.

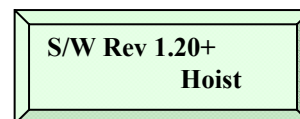

#### 4.3.6.5 Return to Hoist...

Press the menu scroll button to return to the Hoist Menu.

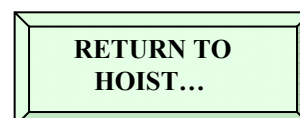

#### 4.3.7 Drive Control...

This menu is the entry point to view Drive Control information (Angle, Horizontal Distance, S/W Rev) and change Drive Control parameters (Drive interlock En/Dis). Rotate the menu scroll knob to step to the Remote... menu or press the menu scroll knob to view Drive Control information.



#### 4.3.7.1 Drive Control Distance and Angle

The top line displays the total distance the carriage has traversed down the main cable, with the main cable angle. (Note the special symbol that indicates an angle) The bottom line displays the equivalent horizontal distance – taking the angle into account. (Note the arrow indicating it is the horizontal distance)

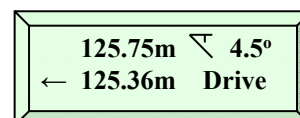

Rotate the menu scroll knob to step between the Drive Control menus.

#### 4.3.7.2 Drive Control Interlock and Inclinometer

The Drive Control-Interlock is a small black box that bolts onto the main cable. This box has 2 functions : to measure the angle of the main cable, and to monitor the position of the carriage as it approaches the Drive Control System using an ultrasonic

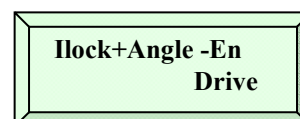

proximity sensor. When the carriage is within about 0.5m of the interlock, the Drive Control Motor is shut-down, preventing it from being driven into the Drive Control enclosure. If the interlock / inclinometer is misplaced, the system cannot be used – so a facility is provided to disable the requirement of the interlock. **NOTE** that disabling the interlock is a safety hazard and should only be done when absolutely necessary.

Press the menu scroll knob and the “En” or “Dis” will start flashing. Rotate the menu scroll knob to select the desired option and press the menu scroll knob again to save the selection.

**4.3.7.3 Drive Control S/W Rev**

The top line of the LCD displays the Drive Control Software Revision. This allows us to check compatibility without opening up any equipment.

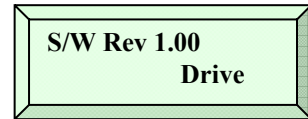

**4.3.7.4 Return to Drive Control...**

Press the menu scroll button to return to the Drive Control... Menu.



**4.3.8 Remote...**

This menu is the entry point to view the Remote Control information (Battery Voltage, Charging Status, S/W Rev) and change Remote Control parameters (Backlighting, Sounder, Units, Operating Frequency). Rotate the menu scroll knob to step to the Alarms... menu or press the menu scroll knob to view Remote Control information.

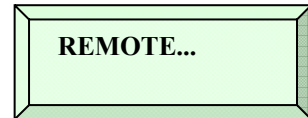

**4.3.8.1 Remote S/W Rev and Battery Voltage**

The top line of the LCD displays the Remote Control Software Revision and the bottom line displays the voltage of the batteries inside the Remote Control.

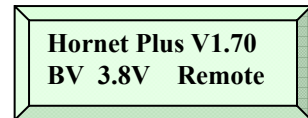

**4.3.8.2 Remote Sounder, Backlight and Units**

The top line of the LCD displays the present state of the Sounder (Enabled or Disabled) and the present state of the Backlight (Always Off, On for 1 Sec, 2 Sec,...9 Sec after a control is touched, or always On).

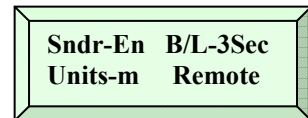

The bottom line of the LCD displays the state of the system Units (either meters or feet). These options can be changed as follows : Press the menu scroll knob and the sounder “En” will flash, rotate the knob to change the selection, and press the knob again to save the selection. When the menu scroll knob is pressed again, the backlight option will flash – rotate the menu scroll knob to change the selection and press the knob to save the selection. When the menu scroll knob is pressed for a third time, the units “m” will flash – rotate the knob to change the selection and press again to save the selection.

**4.3.8.3 Communication Frequency and Charger Status**

The top line of the LCD displays the present communication frequency selected (902.5MHz to 914.5MHz is license free in the US and 915.5MHz to 927.5MHz is license free in Australia) and the bottom line of the LCD displays the Charger status (either Off, On or trickle charge).

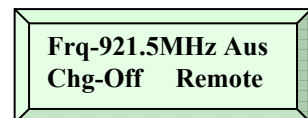

**\*\*\*NOTE\*\*\* Before changing the communication frequency, make sure that both the Hoist and Drive Control are powered on and communicating properly. When the Frequency is changed on the Remote Control, it automatically updates it in the Hoist and Drive Control electronics !!!**

When then menu scroll knob is pressed, the frequency “921.5” and the “Aus” will flash, rotate the knob to change to one of 26 different frequencies, and press the knob again to save the selected frequency and issue a request to the Hoist and Drive Control electronics to

change their frequency as well. The communications will continue seamlessly at the new frequency.

If for some reason there is no communications between the Remote Control and either the Hoist or Drive Control, then simply return to the last frequency used ( or step through, select and save each of the 26 different frequencies one at a time, until it picks up communications again ) – and then step to the new required frequency.

**4.3.8.4 Return to Remote...**

Press the menu scroll button to return to the Remote... Menu.

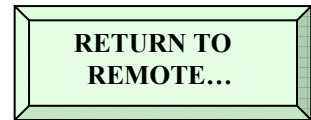

**4.3.9 Alarms...**

This menu is the entry point to view the Alarm Status information (Communications, battery voltages and Drive Control Interlock status) Rotate the menu scroll knob to step to the Return to Main Display... menu or press the menu scroll knob to view the Alarm Status.

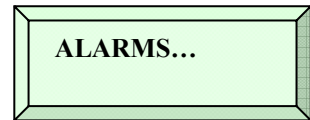

**\*\*\* NOTE \*\*\* If the red LED is on, then it will be due to one of the following alarms !**

**4.3.9.1 Communication Status**

This menu displays the present communication status of the Hoist and the Drive Control. (Note that 2 consecutive missed communication polls is classed as a communication fault !)

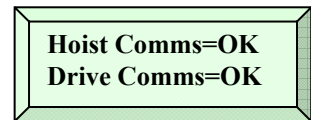

**4.3.9.2 Battery Voltage Status**

This menu displays the present condition of the Hoist battery and the NiMh batteries inside the Remote Control (My Batt).

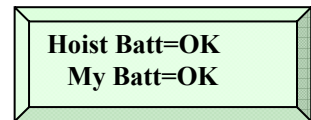

Hoist Battery states : Greater than 11.7V           => OK  
                                   Between 11.4V and 11.7V   => Low  
                                   Less than 11.4V                   => Flat  
                                   No Hoist Comms                   => ----

My Battery states : Greater than 3.7V           => OK  
                                   Between 3.45V and 3.7V       => Low  
                                   Less than 3.45V                   => Flat

**4.3.9.3 Drive Interlock Status**

This menu displays the present condition of the Drive Control Interlock (that is the proximity sensor and inclinometer that bolts onto the main cable, and plugs into the motor).

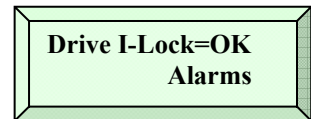

Interlock states : Plugged in and nothing is close   => OK  
                                   Plugged in and object too close   => Stp  
                                   Not plugged in                       => Flt  
                                   Disabled in Interlock menu       => Dis  
                                   No Drive Control Comms           => ----

#### 4.3.9.4 Return to Alarms...

Press the menu scroll button to return to the Alarms... Menu.



#### 4.3.10 Return to Main Display...

Press the menu scroll button to return to the Main Display menu.



### 4.4 System Operational Steps

The following steps should be followed when setting up a system for gauging :

1. Fit batteries and hand winch onto the carriage.
2. Raise the Hoist into position using the hand winch and secure the carriage with the locking pin and spring clip.
3. Raise the Hoist aerial, connect the batteries and turn on the Hoist.
4. Fit the weight and current meter onto the Hoist. (Hornet Plus only)
5. Measure the distance from the bottom of the Hoist to the bottom of the weight and set the “Main cable to weight distance” (See 4.3.3.3) (sets a vertical reference) (Hornet Plus only)
6. Zero the Hoist angle (See 4.3.3.4) (Hornet Plus only)
7. Fix the Drive Control Interlock onto the main cable and plug it in.
8. Apply generator power to the Drive Control.
9. Position the weight and “Set the Waters Edge”. (See 4.3.3.2) (sets a horizontal reference)
10. Traverse to where vertical measurements will be taken, lower the weight and “Set the Water Level” (See 4.3.3.1) (Hornet Plus only)
11. Lower the weight and read the corrected water depth. (Hornet Plus only)
12. Perform gauging on this vertical and go to step 10.

When using the Hornet / Hornet Plus with an ADCP, only the horizontal distance is important. Therefore omit steps 5, 6, 10, 11, and 12.

## 4.5 The Hoist

Under the hoist there is a push on / push off type power switch. Push it, and the blue LED under the hoist indicates power is on. There are 2 x 50A Fuses inside the Hoist.

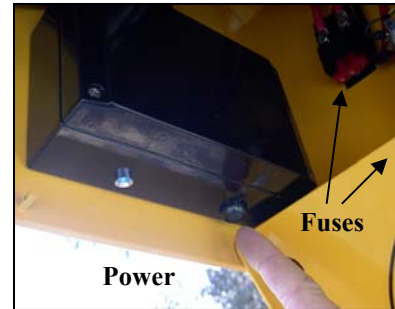

The hoist cable has a conical device clamped near the end of the cable. As the hoist cable is almost completely wound in, the conical device on the cable will press onto the rollers, causing a limit switch to stop the hoist. This prevents the hoist from self-destructing if it is wound up too far. A limit switch is also operated if the cable is let out too far. This will stop the drum with about 3 wraps remaining, to hold the heaviest weight used.

### 4.5.1 The Current Meter (Hornet Plus only)

The Hornet Plus Hoist has a current meter signal processor built in, to clean up the current meter signal. Whenever the hoist is raised or lowered, the current meter signal processor performs a calibration so that water conductivity is accounted for when monitoring the current meter signal. The operator can also select the type of filtering depending upon the type of current meter fan that is connected. The operator can select either Mag Head or Cats Whisker as well as Normal or Slow operation. (See 4.3.5.2) After the signal is cleaned up, the pulses are counted and transmitted to the handheld Remote Control that outputs the pulses to the users favorite current meter counter.

**Tech Talk** - In any radio transmission system, there will be the occasional missed message. Due to the critical nature of the current meter pulse accuracy, special precautions have been taken in the software to ensure that the pulse count and the pulse rate is maintained, even in the event of communication errors. The system uses message numbering in the protocol to ensure that the pulse count is 100% accurate. A PID control loop is used to ensure that the pulse rate measured at the Hoist is the same as the pulse rate output by the Remote Control. A one second buffer is used so that any missed communication messages do not interrupt the output pulse data stream. (In the same way that a walkman has anti-jump data buffering.) Due to this you will notice a 1 second delay between the input and output at fast pulse rates. This has been done to ensure your data integrity!

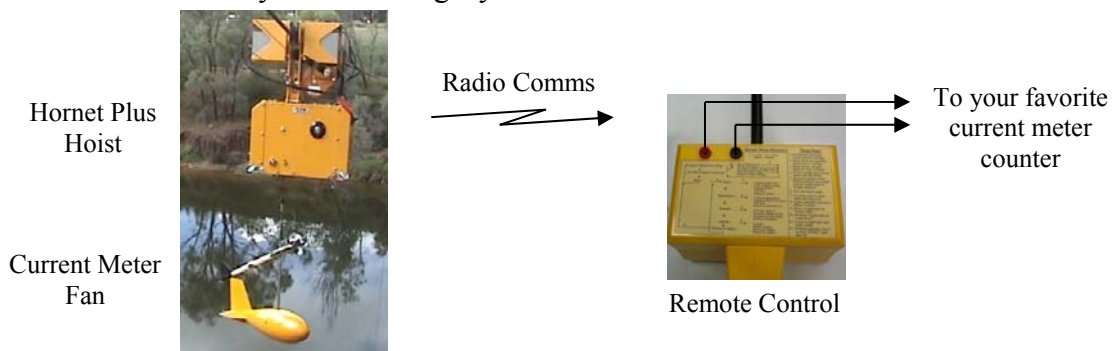

#### 4.5.2 The Hoist Depth and Angle Measurement (Hornet Plus only)

The Hornet Plus Hoist has an optical encoder that measures the cable drum rotation – so that vertical depths can be measured. An inclinometer built in to the Hornet Plus Hoist also measures the angle of the cable. (The Hoist pivots on the main cable, and when heavy gauging weights are used, the angle of the Hoist is approximately the same as the angle of the cable.)

Using this information, the Airline, Wetline and corrected depths are automatically calculated. (See 4.3.2)

#### 4.6 The Drive Control System

The Drive Control system consists of several parts. The electric motor / gearbox and brake assembly drives the pulley arrangement. An encoder on the motor allows horizontal distance information to be calculated. The brake stops the pulley from rotating when the motor is stationary. (A manual brake lever provides an over-ride mechanism.) The Drive Controller is mounted in a stainless steel enclosure.



The Drive Interlock is a black box that is mounted on the main cable. This device has 2 functions – to monitor the position of the Hoist carriage, and to measure the angle of the main cable. Make sure that the “This Way Up” indicator is pointing up, and that the two lower mounting bolts are both in contact with the main cable. This ensures that the internal inclinometer can accurately measure the angle of the main cable. When the carriage comes within about 0.5m, the Drive Control motor is shutdown, preventing the carriage, the pulley and personnel from being damaged.

Simply plug the mains output from a portable generator into the bottom of the Drive Control stainless enclosure, and start the generator.

## 5. Specifications

### Drive Controller

Enclosure	Stainless Steel 600 x 600 x 300 mm (24" x 24" x 12")
Power Requirements	0.8KW 110 VAC / 240 VAC (2 separate models) (1000 Watt Generator or Mains Power)
Overload Capacity	150% for 60 Sec
Interlock	Ultrasonic proximity set to 1.3m
Inclinometer	± 45° measurement

### Electric Motor

Motor Body	IP65, Geared Motor
Speed	Drives carriage up to 1 m/s (3.2 ft/s)
Distance Measurement	0.01m / 0.01 ft resolution
Output Torque	32 Nm
Safety Factor	1.8
Power Requirement	0.75kW 110 VAC / 240 VAC

### Hoist (Hornet and Hornet Plus)

Lifting Capacity	100 Kg / 220 lbs (135kg / 300lbs also available)
Power Requirements	2 x 12 VDC 38 Ah Batteries 2 x 50 Amp Fuses
Cable	45m of Amergraph cable
Depth Measurement	0.01m / 0.01ft resolution (Hornet Plus only) Conforms to USGS Water Supply Paper 2175
Ground Feeler	Detects river bed
Inclinometer	± 45° measurement (Hornet Plus only)
Current Meter	Built in signal processor (Hornet Plus only)

### Hoist (Sediment Sampler)

Lifting Speed Control	0.01 to 0.73m/s (0.02 to 2.39ft/s)
Lifting Capacity	45 Kg / 100 lbs
Power Requirements	2 x 24 VDC 20 Ah Batteries (ABS 24V20T4LT) (181mm x 149mm x 167mm) (7.1" x 5.9" x 6.6") 2 x 40 Amp Fuses
Cable	45m of Amergraph cable (Power driven sheave and grooved drum to ensure cable lays evenly)
Depth Measurement	0.01m / 0.01ft resolution Conforms to USGS Water Supply Paper 2175
Ground Feeler	Detects river bed
Inclinometer	± 45° measurement
Current Meter	Built in signal processor

**Remote Control** (completely wireless)

Controls	Raise / Lower Control + Battery Voltage monitoring Forward / Reverse + Speed control
LCD	16 char x 2 line with backlighting Calculates horizontal distance and vertical depth etc.
Radio Frequency	USA 902.5 to 914.5 MHz AUS 915.5 to 927.5 MHz (26 channels @ 1MHz spacing) Operating Range 1km (0.62 miles) line of sight
Indicators	LEDs for comms and fault indication
Outputs	Current Meter Output – Open Collector Sounder for current meter pulses
Power Source	3 x NiMh 2.5Ah AA batteries with built-in charger (3 x AA Alkaline batteries in an emergency)



## Appendix A. Routine Maintenance

There are a few routine maintenance steps that should be performed, to ensure continued safe operation of your Hornet system.

### Drive Control

1.

Grease the Drive Control tension pulley shaft.

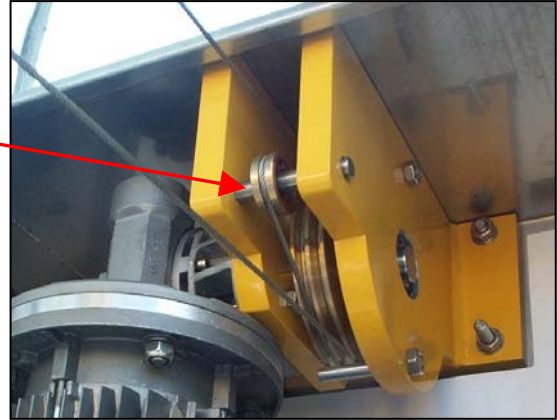

### Hoist

2.

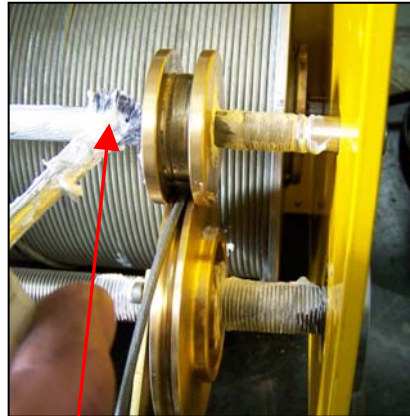

Grease the Hoist sheave guide pulley shaft.

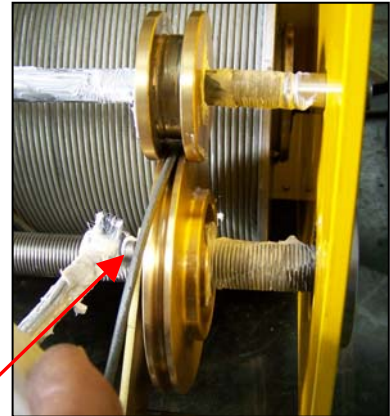

Grease the Hoist sheave shaft.

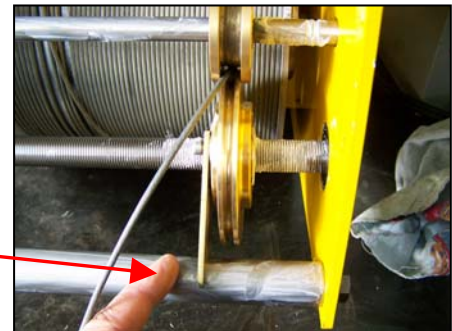

Lightly grease the Hoist guide shaft.

3. Check that all nuts and bolts on traveller block are still tight and that turnbuckles and traversing tension is appropriate.
4. Check traversing cable for any visible signs of wear.
5. Check Manual Winch cable for fraying.
6. Check that Hoist cable is laid neatly on to the hoist drum

## Appendix B. Startup Guide – Hornet Plus

1. Assure that traveler block is located over a safe working space. If it is not, plug in Drive Control Box, turn on the Remote Control and drive Traveler Block over a safe space. **DISCONNECT** power to the Drive Control Box until Hoist is fully set up.
2. Attach the supplied 12V power leads to the 40Ah batteries.
3. Place batteries in boxes and attach the Manual Winch in the order explained below.  
Page 19  
**\*IMPORTANT\*** Place battery opposite from where winch goes first securing the latch, then attach winch and last attach battery above the winch as per manual. This keeps balance and helps maintain safety.
4. Feed Manual Winch Cable through the hole in the Traveler Block plate, ensuring the cable is aligned in the brass roller.
5. Lower the Manual Winch Cable and attach to the Hoist. Page 20  
**\*IMPORTANT\*** Check that there are no signs of fraying on the winch cable prior to raising.
6. Raise and secure Hoist antenna. Page 20
7. Lift Hornet Hoist and secure to Traveler Block using pin and R-clip. Page 21
8. Connect power from both batteries to the Hoist using the red anderson plugs.
9. Attach Drive Control Interlock to the top of the main cable. Page 22.  
**\*IMPORTANT\*** Box must be parallel with the main cable to ensure correct angle measurement
10. Plug the Drive Control Interlock into the Drive Control Box using mil spec connector
11. Attach the antenna to the Drive Control Box.
12. Assemble gauging equipment including the current meter to the hanger bar.
13. Attach the GFD to the top of the hanger bar.
14. Turn on Hoist using blue push button. Page 23
15. Turn on Remote Control. Page 23
16. Using the remote control, lower the Hornet Hoist cable to release tension on the C1 Connector and remove from securing spring. Page 23
17. While pulling down on the Hoist cable, use the remote control to lower the C1 connector to the GFD and secure using the pin and R-clip.

18. Attach angle plug to the GFD and secure with clamp. Page 53-55
19. Raise the gauging weight slightly off the ground to assure that the GFD is in its open position.
20. Power up the Drive Control Box
  - a. Open both doors on the Drive Control Box while operating the Hornet Plus system.
  - b. Plug in portable generator to Drive Control Box
  - c. Turn the generator on. Once the generator is supplying power, the Drive Control Box will be operational.
21. Using the Remote Control
  - a. Page 24 & 25 outline the features of the Remote Control
  - b. Turn Remote Control on using blue power button if it is not already turned on.
  - c. Connect current meter counter to Remote Control. Spin the fan and the counter should register the pulses. The blue light on the Remote control will also light up with each revolution.
  - d. Set Main Cable to Weight distance. Page 30 (4.3.4.3)
  - e. Set Offset from weight to meter. Page 31 (4.3.4.4.)
  - f. Zero the Hoist Angle. Page 31 (4.3.4.5)
22. Conduct gauging as normal to local standards.

## Appendix C. Troubleshooting Guide

### 1. Remote Control

#### a. Remote not communicating with Hoist or Drive Control Box

Turn on **both** the Hoist **and** the Drive Control cabinet. On the Remote Control, navigate to the Remote menu that displays the operating frequency. Press the “Select” button :

- i. If S/W Rev 2.4 or above is installed, and either the Hoist or Drive Control is not communicating, it will display the message “To Srch->Press z”. When the blue “Zero” button is pressed, the Remote Control will search through all 26 frequencies (3 times) to find the Hoist and Drive Control. If they are found it will tell them to change to the selected frequency. If they are not found, the Remote Control will just operate at the selected frequency.
- ii. If the S/W Rev is below Rev 2.4, you will need to Scroll to the first frequency and press the Select button. If the Hoist and/or Drive Control are found they will start communicating. If they are not found press the Select button again and Scroll to the next frequency. Repeat this process until the Hoist and Drive Control start communicating.

#### b. Remote Control LCD not operating properly and cannot navigate menus.

- i. Make sure the Remote Control NiMH batteries are fully charged – or replace them temporarily with 3 x 1.5V AA alkaline batteries. (DO NOT plug the charger into the Remote Control while alkaline batteries are installed !!!!)
- ii. Remove the Remote Control front cover (remove the 4 x corner screws), and check that the ribbon cable is firmly pushed into the multipin socket on the LHS of the circuit board.
- iii. Remove one battery from the holder and then put it back in again, to force the Remote Control to perform a hard reset.

#### c. Remote Control battery is not lasting after being charged

Check the Remote Control software revision by navigating through “More..” to the Remote menu’s. Make sure it has software Rev 2.4 or higher – this will ensure it has the correct NiMH battery charging algorithm.

When the charger is plugged into the Remote Control, the display will automatically come on and the battery symbol will indicate it is charging – leave it charging for 4 to 4.5 hours – after this time it will automatically drop back to a trickle charge.

Remove the 3 x NiMH batteries and try charging them in a commercial NiMH battery charger – if they still won’t hold their charge replace them with new NiMH batteries and recharge the Remote Control.

#### d. Green light is flashing but the Red light is also on

The green LED flashes each time it communicates with either the Hoist or the Drive Control unit – the red LED on does mean there is a problem. Navigate through “More...” to the “Alarms...” menu to see what the problem is. It could be one of the following:

- i. Hoist or Drive Control comms error.
- ii. Hoist battery is low.
- iii. My battery is low (ie. Remote Control battery)

- iv. Drive Interlock cable fault (ie.Motor Drive Interlock/Inclinometer box is enabled but not plugged into the Motor Drive cabinet) If you don't have the box, you can navigate to the Drive Control menus and Disable the "ILock+Angle" function.
- v. Hoist Cable Fault (The Hoist cable is loose on the drum and touching the sense bar).

**e. Traversing Distance not measuring correctly**

The angle measurement on the main cable isn't being measured properly:

- i. If the error is small, maybe the Motor Drive Interlock/Inclinometer box isn't plugged in to the Motor Drive Cabinet, or it is disabled – and so an angle of 0 degrees is assumed.
- ii. If the error is large, then maybe the Motor Driver Interlock/Inclinometer is mounted upside down on the main cable and hence the angle is measured as 45 degrees. Navigate to the Drive Control menu and see what angle is being measured. (Sometimes the lid of the Interlock/Inclinometer box is removed and put back on upside down, and so the "This Way Up" arrow appears to be OK)
- iii. The mounting of the Motor Drive Interlock/Inclinometer on the main cable is important – make sure that the two top bolts sit down on the cable – and that it is not mounted at a strange angle.

**2. Drive Control Cabinet**

**a. Driving forward but the traveler block is not moving.**

This may mean that the drive control motor has ceased. Manually release the brake using the manual brake release lever. This will only move slightly. Try to drive the system again.

**b. The Drive Control doesn't have enough power to drive the loaded carriage up the main cable.**

Systems supplied before Apr-2011 may have had the AC motor wired in a "Star" configuration which limits the drive capability. Rewiring this in a "Delta" configuration dramatically improves the drive capability – Contact Hyquest Solutions for a data sheet on how to correct this – the change only takes 10 minutes – and should only be attempted by qualified personnel.

**c. The numeric display in the Drive Control cabinet is flashing.**

It does depend what is flashing – if it is just a number flashing then there is no problem – this is normal. Other flashing codes could indicate a problem:  
OV – Over Voltage (check generator output)  
LV – Low Voltage (check generator output)  
OH – Over Heating (power down and wait for it to cool down)  
OC – Over Current (power down and up again, maybe the motor / cable is jammed)

**d. Drive Control cabinet isn't working – there are no LEDs on the drive controller.**

- i. Check that the cable between the generator and underneath the Drive Control cabinet is plugged in firmly.
- ii. Look inside the Drive Control enclosure with the clear lid and see if the Circuit Breaker has tripped. If so, turn off the generator, remove the enclosure clear

cover, turn on the circuit breaker, refit the clear cover and plug back in the generator. Please be careful as Mains Voltages are present inside this enclosure.

- iii. Check that the generator is operating and creating the correct mains voltage using a DVM.

### 3. Hoist

#### a. Hoist clicks and doesn't move up or down.

- i. Check the battery connections. When the Hornet or Hornet Plus Hoist motor operates, it draws 50A from the batteries. A loose bolt connection or a badly crimped terminal will cause the voltage to droop under load and the hoist controller to reset.
- ii. Check the plug in power connectors – that a terminal hasn't been dislodged in the housing.
- iii. Check both fuses are OK (if one is blown, then the Hoist will only be running on one battery).
- iv. Make sure that the hoist cable is wrapped properly on the drum, and is not jamming the drum rotation.

#### b. The Sediment Sampler Hoist moves upward very slowly ?

All of the Hornet family Hoists have limit switches to stop the upward operation at the end of the cable to prevent damage. The Hornet and Hornet Plus Hoists operate relatively slowly and so the limit switch on its own is sufficient. However the Hornet Sediment Sampler, with hoist speed adjustment, can operate very fast – and the limit switch on its own would not stop the hoist upward operation fast enough to prevent damage - therefore additional protection has been added. The hoist remembers the position of the drum when power is switched on, and it will only drive upwards slowly from that position. So if the Hoist power is turned on while the lifting cable is extended, it will only drive slowly from that position upwards.

To fix this problem, drive the hoist upwards and when close to the fully up position, cycle the hoist power.

#### c. Can the SLA batteries on the carriage be mounted on their side ?

- i. Yes, sealed lead acid batteries can be used upright or on their side, but should not be operated upside down. If in doubt consult the battery manufacturer datasheet.
- ii. When fitting the batteries to the carriage battery box, ensure there is sufficient clearance between the battery terminals and the battery box itself – fit rubber or plastic insulation if the clearance is tight.

#### d. The Hoist “bottom detect” (ground feeler) doesn't appear to work properly?

- i. Remove the “Angle-plug” from the ground feeler device and the current meter, and touch the plug connector onto the outside of the ampergraph cable – this should turn on the blue LED, the same as the ground feeler operating or the current meter turning. Try turning the Hoist off and on again and retry.
- ii. Remove the Angle-plug from the ground feeler device and try the Current Meter on its own to see if it generates pulses – to see if it flashes the Remote Control blue LED. Note that if the current meter isn't rotating, and the internal

contact was closed, then it would give the same effect as the ground feeler contact being closed.

- iii. Check the amergraph angle plug signal pin is screwed in securely – when it is screwed up tight, it makes electrical contact to the amergraph signal wire.

**d. The Current Meter connected to the Hoist is not generating pulses as the fan rotates?**

- i. Make sure there is communications between the Hoist and the Remote Control.
- ii. Check that the Remote Control “Hoist” menus have the current meter options set to “MagHd” and “Nrm”.
- iii. If the blue LED is flashing as the Current Meter rotates, maybe there is a connection problem between the Remote Control banana socket and the Current Meter Counter.
- iv. Use the following Troubleshooting Chart :

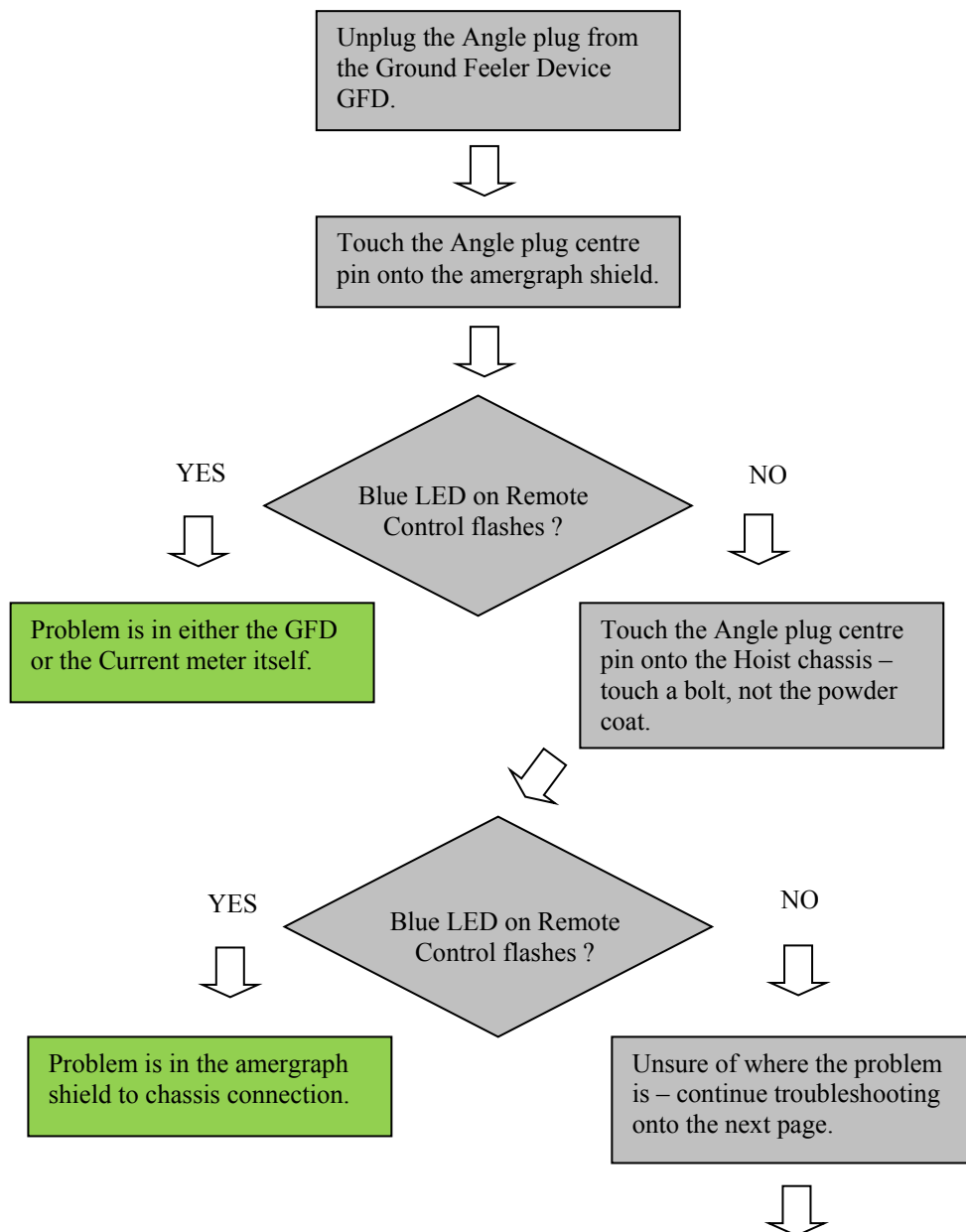



Remove Hoist electronics lid.  
Unplug 2 pin connector from  
Hoist electronics.



Short the 2 pin header on the  
PCB.

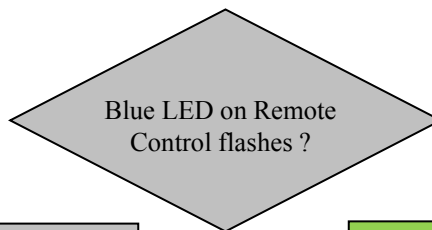

YES  
↓

Problem is in the Amergraph  
cable to PCB connector.  
Continue on to isolate this  
problem.

NO  
↓

Problem is in the Hoist Control  
PCB to Remote Control. Try a  
different Remote Control or a  
different Hoist Control PCB.



The Amergraph cable on the Hornet Hoist drum, has an outer shield and inner signal wire which follow different paths to the Hornet Hoist control electronics 2 pin header.

The amergraph cable shield follows the path :

- Cable Shield to
- Drum body through to
- Drum bearing to
- Bolt and washer supporting the drum to
- Screws in washer to Hoist chassis side plate to
- Black wire screwed to side plate that goes to electronics 2 way screw terminal J5-

The amergraph cable signal wire follows the path :

- Centre wire of angle plug to
- Amergraph signal wire to
- Drum slip ring to
- Brush to
- Red wire to the electronics 2 way screw terminal J5+



Disconnect the Hornet Plus 12V and turn off the Remote Control.  
The following tests can be done with a multimeter.

NOTES :

- a. When a multimeter is in “Continuity Mode” (beep mode) it is difficult to know what the actual resistance is, because all multimeters have a different threshold. So it is better to put it into “Resistance” mode, so you can tell the actual resistance. (There are also two diodes in series between J5+ and J5- on the circuit board that may confuse multimeter readings in the continuity mode !)
  - b. It is also important to have the electronics powered down when measuring resistance, as the currents flowing from the electronics can upset the multimeter resistance reading.
1. With the red wire disconnected, measure the resistance between the amergraph shield and the centre wire. It should be open circuit (in the Meg ohms) otherwise you need to find where the short circuit is. It is most likely in the Amergraph angle plug connector.

2. With the red wire still disconnected, check the resistance between the Amergraph connector (centre pin) and the brush housing. This should be low resistance (approx < 10 ohm). If it is open circuit the problem could be the Amergraph angle plug connector or the slip ring brush. If you suspect the brush, go to step 4.

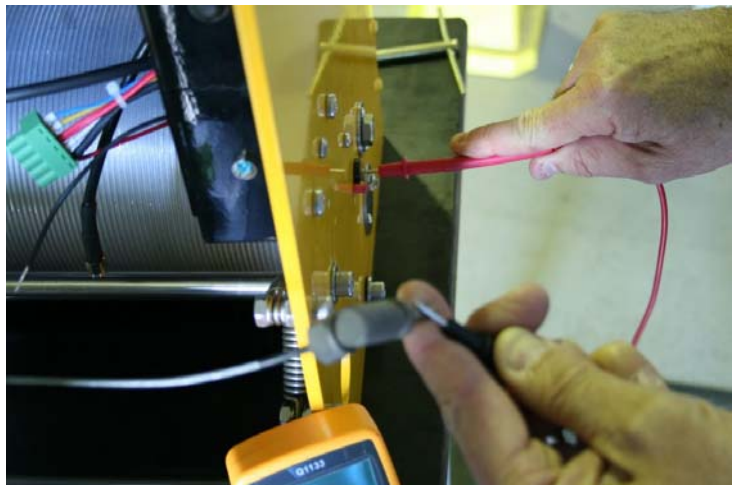

3. Remove the slip ring brush by undoing the bolt as shown and...

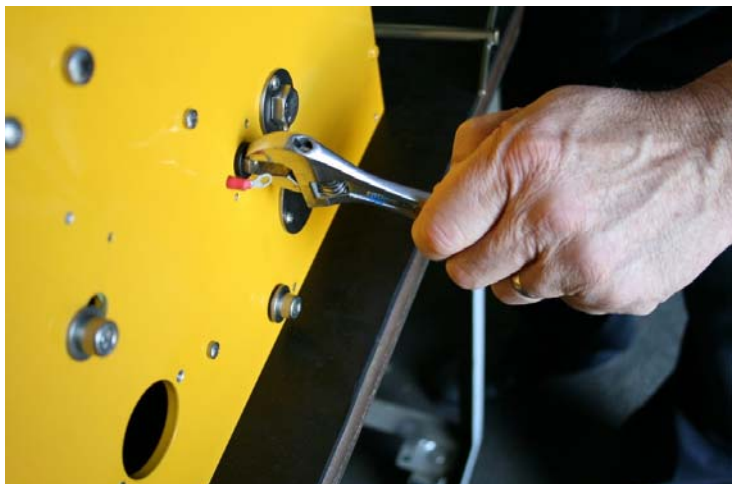

4. Extract the brush and spring.  
Make sure the spring is not bent or distorted, and the brush slides smoothly in the housing. You can do a visual check that the brush touches the slip ring and makes proper contact.

Go back and repeat step 2 until the circuit is OK.



5. To test the shield continuity set the multimeter to resistance and measure different parts of the same circuit to isolate a problem, referring to the signal path list. Eg From the drum to the black wire J5- (shown) or from the drum to the securing bolt washer....



## Appendix D. Corrected Depth Calculation

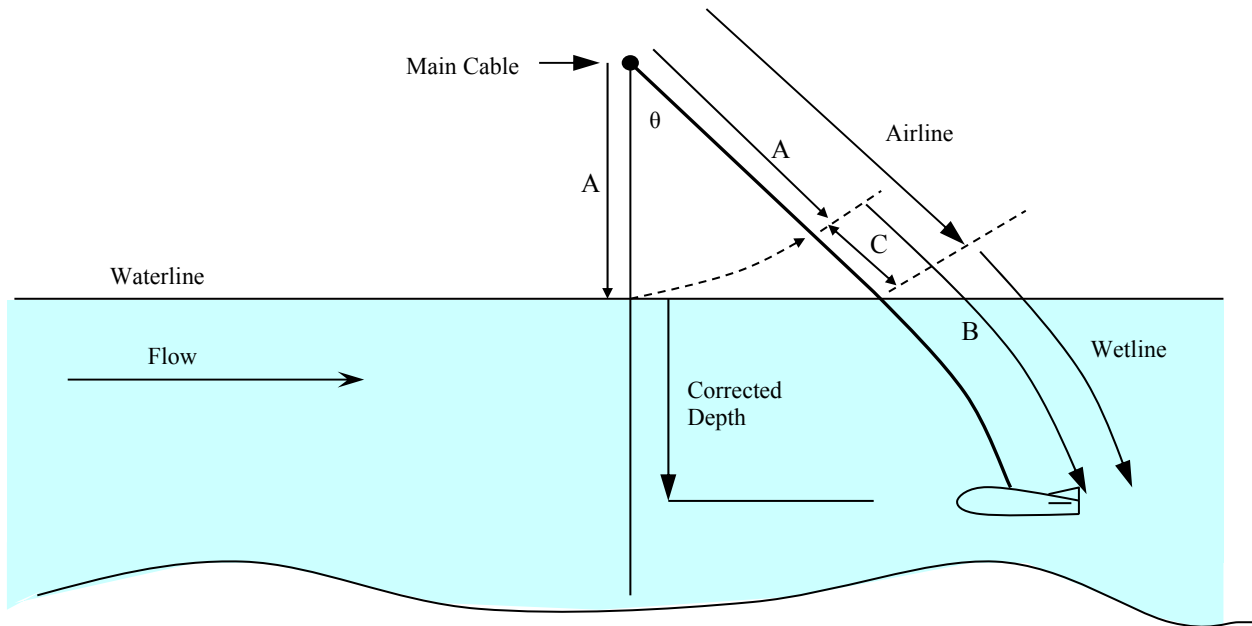

\*\*\* Look at the right angle triangle above the water \*\*\*

$$\cos \theta = A / (A+C)$$

$$A+C = A / \cos \theta$$

$$C = A / \cos \theta - A$$

**Air Line Correction**

$$\begin{aligned} \text{Airline} &= A + C \\ &= A + A/\cos \theta - A \end{aligned}$$

$$\text{Airline} = A/\cos \theta$$

$$\begin{aligned} \text{Wetline} &= B - C \\ &= \text{Total Cable} - \text{Airline} \end{aligned}$$

$$\text{Wetline} = \text{Total Cable} - A/\cos \theta$$

\*\*\* Consider the cable under the water \*\*\*

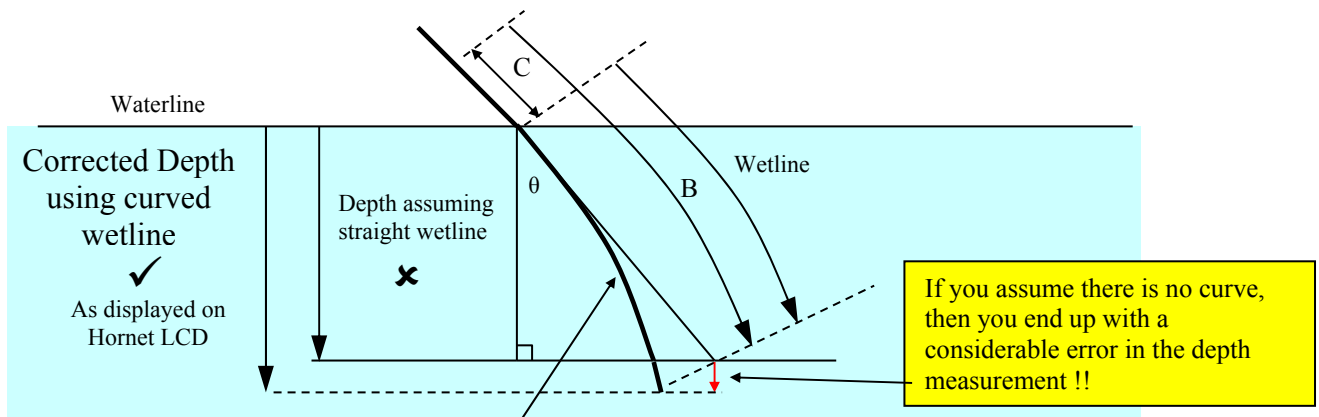

The cable under the water has a curve due to the force of water on the cable.

**NOTE :** The Corrected Depth is calculated dynamically using a proprietary formula developed by Hyquest Solutions. The resultant Corrected Depth is in accordance with the USGS "Measurement and Computation of Stream Flow Vol 1." Water Supply Paper 2175

## Appendix E. Ground Feeler Device Model GFD

### Introduction

The Ground Feeler Device is a mechanical spring loaded attachment that can be used in conjunction with any Hornet Plus gauging winches fitted with Amergraph cable and connected to a Columbus pattern gauging weight.

The unit is designed to alert the operator that the gauging weight has come in contact with the streambed during a gauging operation.



*Ground Feeler Device Model GFD*

Note:

A current meter cable is supplied with the Ground Feeler Device (GFD) so it can be connected to the operator's current meter. The customer must specify the lead type when ordering the GFD :

**GFD02-AA** for AA type current meters

**GFD02-RB** for Redback type current meters

**GFD02-UNI** for Universal Type Current Meters

(OSS-B1/OTT-C31)

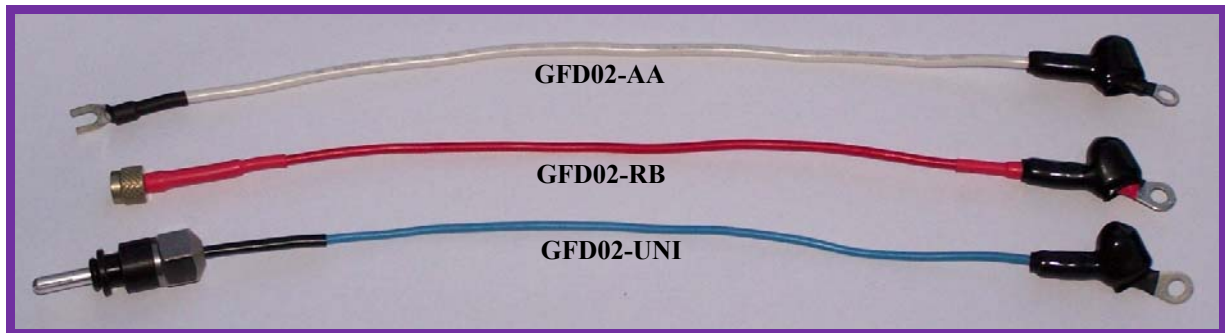

*Current Meter Cable*

When the gauging weight contacts the streambed, the GFD causes the current meter signal to short-circuit. The blue led on the remote control with **software version 1.5 or above** will turn "ON", there will be no signal received from the current meter. This indicates that the gauging weight is in contact with the streambed. Once the weight is raised slightly off the streambed, the blue led will turn "OFF" and normal current meter signal operation will commence.

The GFD eliminates the need to observe the main cable movement on a cableway to determine if the gauging weight comes into contact with the streambed. In situations where the distance is too far to observe the main cable movement, or in a harsh weather conditions, the GFD makes streambed sensing an easy and accurate procedure.

## Installation

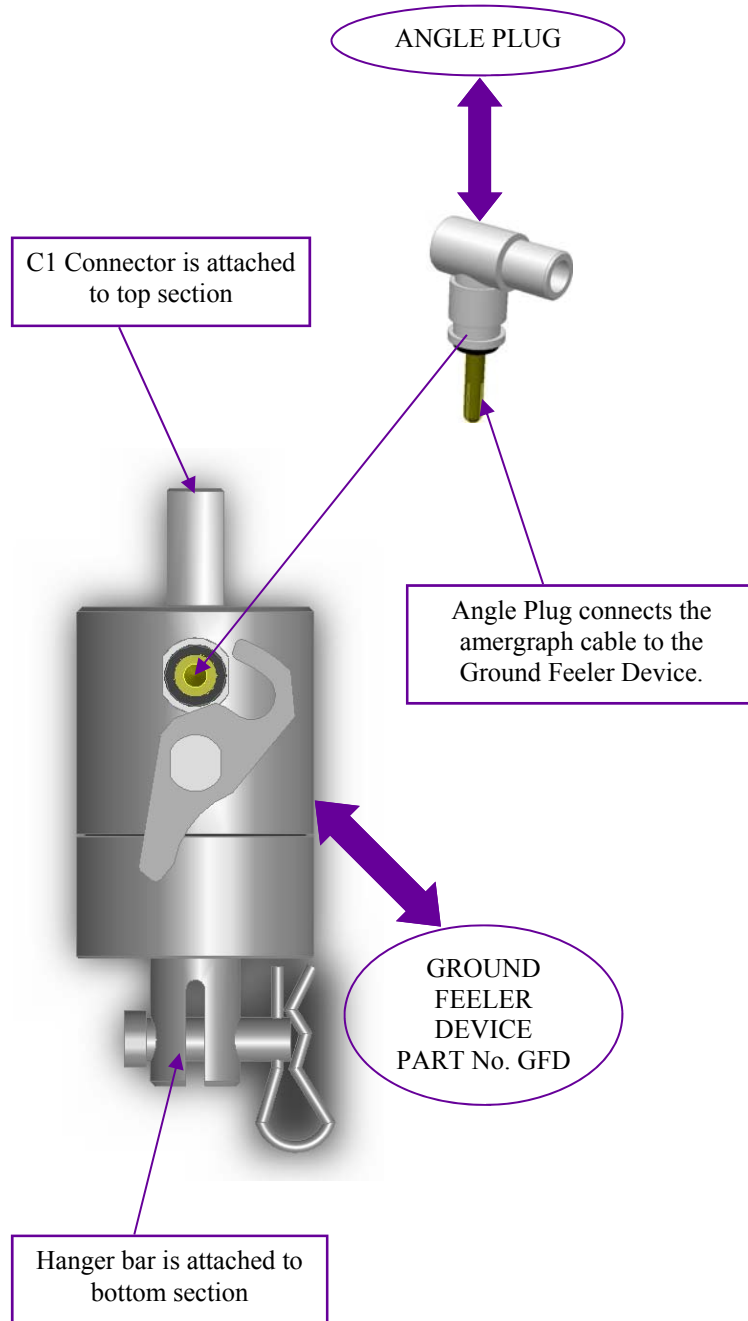

## Operation

- The GFD contact plunger shown in normal gauging position when Columbus weight is attached (i.e. no contact)

Gauging weight is attached; The contact pin moves away from the angle plug contact sleeve (open contact).

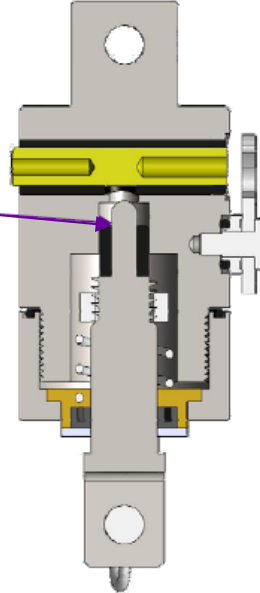

- The GFD spring moves plunger into contact position when Columbus weight reaches the streambed (i.e. continuous beep or no signal received from current meter)

This side is attached to current meter cable (GFD02-AA or GFD-RB or GFD02-OSS). Customer to specify lead when ordering.

This side is attached to Amegraph cable angle plug.

Gauging weight attached; The pin is making contact with the Angle Plug connecting sleeve (closed contact); Gauging weight has reached streambed.

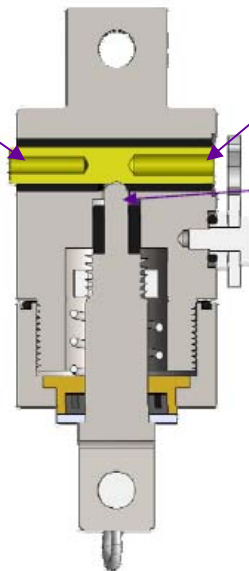

## Appendix F. Adding Control to Drum Cable

This feature has been added to prevent the drum from continuing to feed out cable after the gauging weight has already reached the streambed. Hence, the cable stays reasonably tensioned and does not tangle causing improper winding on the drum, when the gauging weight is lifted back up from the water.

The addition of this feature has been implemented by adding a rod in parallel with the drum, and updating the hoist software version to 1.5 (**Note: any version above 1.5 will include this feature**). This rod is insulated from the hoist body and connected to a wire that is monitored by the hoist control box. When the Gauging Weight touches the streambed, the front layer of the cable on the drum will become loose and touch the rod; this causes the rod “signal” monitored by the control box, to change state and instantly stop the winch motor from feeding out more cable, and displaying a message on the LCD - “Cable Tension”. This function assists in keeping the cable firmly wound onto the drum.

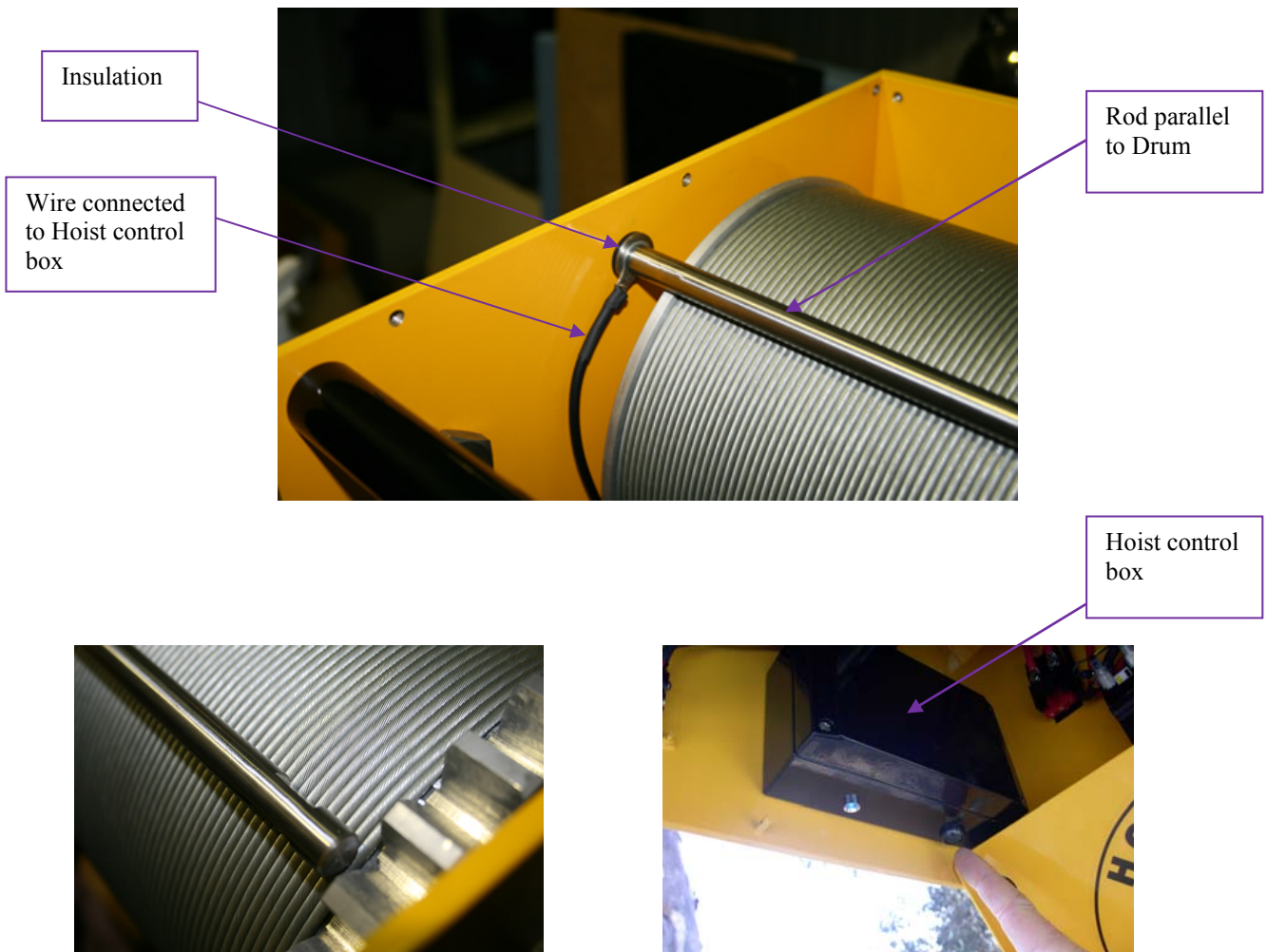

## Appendix G. Sediment Sampler Hoist

The Sediment Sampler Hoist has the following features :

- Variable speed raising and lowering 0.01m/s to 0.73m/s (0.02ft/s to 2.39ft/sec)  
(Precise constant speed provides accurate sampling)
- Automatically lowers to exact preset depth and rises back to the surface, eliminating sampler clogging if accidentally lowered into the river bed.
- Power driven sheave and grooved drum to ensure cable lays evenly.
- Maximum lift capacity 45kg (100 lb)
- 2 x 24V 20Ah batteries required.
- 40m of Amergraph cable.
- Current Meter Signal Processing.
- Depth measurement 0.01m / 0.01ft resolution
- Angle of drift measurement to  $\pm 45^\circ$
- Ground Feeler Device to detect river bed.
- Automatically stops downward motion when cable tension is lost.

The Sediment Sampler Hoist can therefore be used with :

- an ADCP or
- a mechanical current meter and Columbus weight up to 45kg (100 lb) or
- a Depth Integrating Sediment Sampler.

A special Sediment Sampling function has been built into the Remote Control that allows the operator to dial in the depth where the sample is to be taken, and set the vertical speed of the sampler. The operator then simply holds the “Lower” button and the sampler lowers to the preset depth, stops, reverses direction, rises back up and stops at the starting position, indicating on the display that the Sample is complete !



**\*\*\*\* Very Important \*\*\*\*** Please make sure that 2 x 24V DC batteries are used on the Sediment Sampling Hoist !!!

The Power on/off button for the Sediment Sampler Hoist is on the on the side of the Hoist. Simply press the black button and the blue light next to the button will turn on.

When the Remote Control communicates with any Hoist, it automatically detects if it is a Hornet, Hornet Plus or Sediment Sampler – and enables the appropriate menus on the LCD.



## Sediment Sample Sequence

### Step 1 Preparation

**Note :** The operation of the Hoist throughout Step 1 is the same as a Hornet Plus !!!

- Based on your site, work out the location where samples will be taken. eg. A, B and C.
- Fit a **Ground Feeler Device** and a **Depth Integrating Sediment Sampler** or a **Columbus Weight**.
- Locate and “Set Waters Edge...”
- Move to location A and record the distance W1 (See Page 30)
- Lower the weight to the water’s surface and “Set at Water Level...” (See Page 30)
- Lower the weight to the river bed and the Ground Feeler will operate, turning on the blue LED – record the depth D1
- Repeat for locations B and C

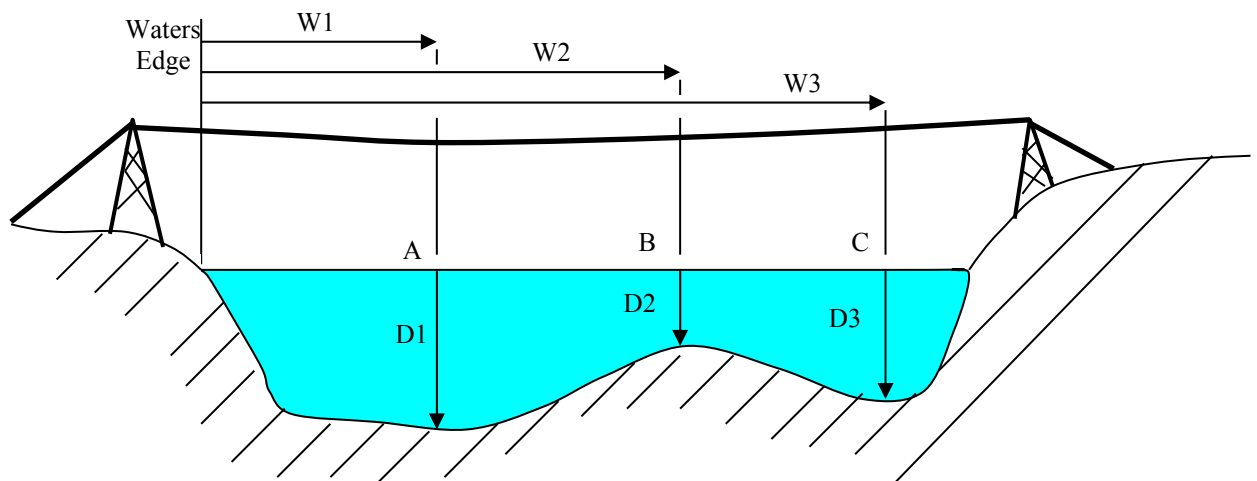

You will now have built up a table as follows :

Sample :	Distance W (m)	Depth D (m)	Vertical Sample Speed	Sample Details
A	12.37	6.58		
B	27.25	2.92		
C	34.92	5.03		

**Step 2 Sampling**

- With sample bottle installed, fit the Sediment Sampler to the Hoist and move horizontally to location A. (← = W1)
- Lower the Sampler to just above the water's surface.

- Set the required vertical speed of the sample by adjusting the "speed" knob and reading the vertical speed on the LCD. (Note the down arrow after the speed indicating that this is the vertical speed)

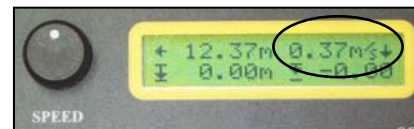

- Perform a "Set at Water Level..." (see page 30)

- Press the "Scroll Menu" knob and rotate to select "Set Water Depth and Sample..."



- Press the Zero button and the display will show "SampleWaterDepth" with the depth flashing !!! Rotate the Scroll Menu knob to set the required depth. You need to set the depth slightly less than the actual water depth, (approx 0.3m or 1ft) so the sediment sampler doesn't hit the river bed. (Rotating the knob fast will cause the numbers to jump farther, so a larger depth can be reached quicker + rotating the knob slower will cause the numbers to jump smaller so you can select the exact depth.)

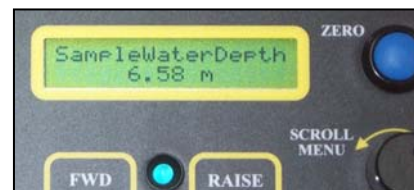

- Press the "Scroll Menu" knob to lock in the depth. The display will show "Water Depth for Sample is Set" and then it will display "Hold 'Lower' to Start Sample". The Hornet system is now in "Sample Mode" indicated by the blue LED flashing once a second.



- **\*\*Please note\*\*** Once in "Sample Mode" pressing Fwd, Rev or Raise will abort the mode. You must return to "Set Water Depth and Sample..." again to prepare for a new sample.



- Now that "Sample Mode" is entered and the blue LED is flashing, simply press and **HOLD** the "Lower" button. The blue LED will flash faster and the Hoist will start lowering the Sampler at the selected speed.

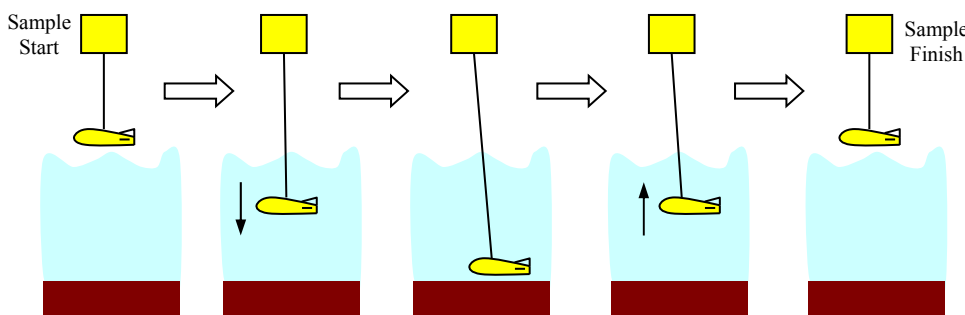

Keep the "Lower" button held during the complete sample sequence.

As shown diagrammatically on the previous page, the Sampler will lower to the preset depth, stop, reverse direction, rise to the starting position and stop. The LCD will display the message “End of Sample” and the blue LED will stop flashing. Keep the ‘Lower’ button held during the complete sample sequence.

**\*\*\* PLEASE NOTE \*\*\***

The Sample sequence will “Abort” if :

- the ‘Lower’ button is released during the sequence.
- the Sampler hits the river bed and the “Cable Tension” alarm occurs. (See Appendix F)
- the ‘Fwd’ or ‘Rev’ button is pressed.

**Speed Control**

The one speed knob is used to control the horizontal and vertical speed. When the ‘Fwd’ or ‘Rev’ button is pressed, the speed displayed is the horizontal speed and a horizontal arrow will appear after the speed. When the ‘Raise’ or ‘Lower’ button is pressed, the speed displayed is the vertical speed and a vertical arrow will appear after the speed. (as shown)



The units (m/s or f/s) can be set in the More... Remote... set of menus.

All of the Hornet family Hoists have limit switches to stop the upward operation at the end of the cable to prevent damage. The Hornet and Hornet Plus Hoists operate relatively slowly and so the limit switch on its own is sufficient. However the Hornet Sediment Sampler, with hoist speed adjustment, can operate very fast – and the limit switch on its own would not stop the hoist upward operation fast enough to prevent damage - therefore additional protection has been added. The hoist remembers the position of the drum when power is switched on, and it will only drive upwards slowly from that position. So if the Hoist power is turned on while the lifting cable is extended, it will only drive slowly from that position upwards. If this issue is a problem, drive the hoist upwards and when close to the fully up position, cycle the hoist power.

**Sample Depth**

When the Sampler is being lowered to the preset Sample Depth, the speed and cable angle is monitored continually, and the Sampler is commanded to stop so that it actually stops at the Sample Depth by using a predictive algorithm. This has been tested and the Sampler stops within 20mm (0.02m = 0.08ft) of the preset Sample Depth, no matter what speed is selected.

## Appendix H. Far Side Installation Guide

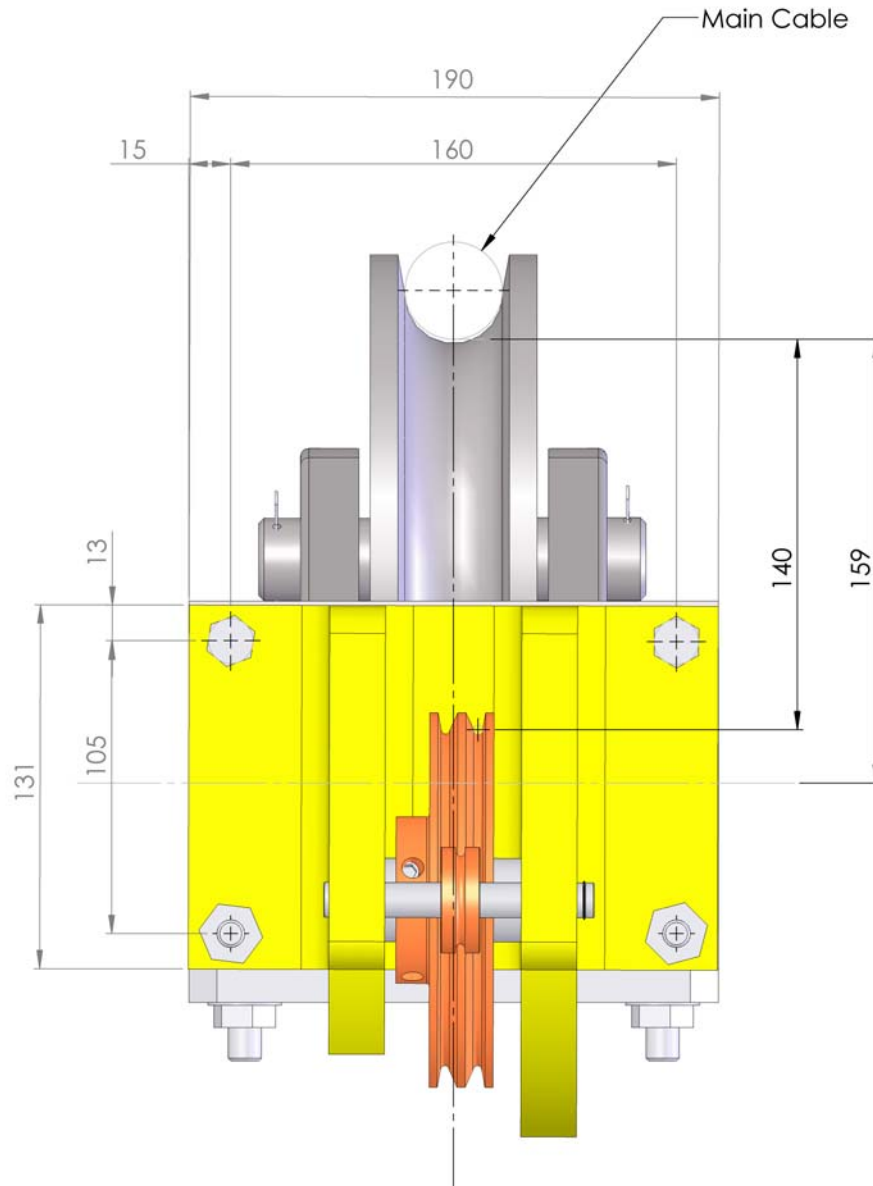

Operating Side & Far Side Distance Between Main Cable & Centre of Sheave Block Back Plate

**NOTE: THE ABOVE DRAWING IS ONLY APPLICABLE IF THE POST HEADS FOR BOTH FAR SIDE AND OPERATING SIDE ARE SUPPLIED BY HYQUEST SOLUTIONS.**

