



OPERATING INSTRUCTIONS & PARTS MANUAL
HIGH PRESSURE OIL-FIRED HEATER
 MODELS 3E358A & 3E359A

FORM
 5S2514
 01582

0689/322
 VP

**READ INSTRUCTIONS CAREFULLY BEFORE ATTEMPTING TO INSTALL, OPERATE OR SERVICE THE DAYTON HIGH PRESSURE HEATER!
 RETAIN INSTRUCTIONS FOR FUTURE REFERENCE.**

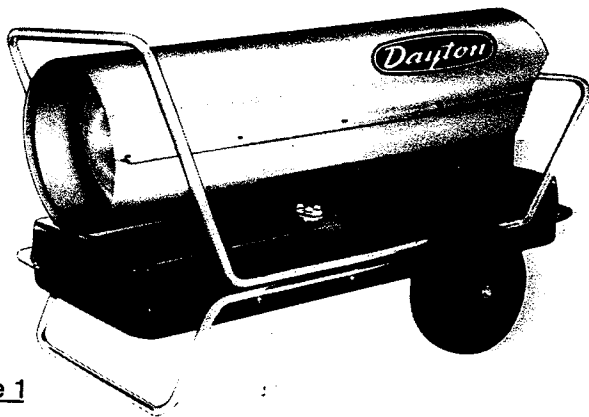

Figure 1

Description

The Dayton high pressure oil-fired heater is designed for use where large amounts of heat are needed. It must be used where adequate ventilation and proper electrical power are available.

This manual contains operating, maintenance and troubleshooting instructions for the heater. A complete parts list is included at the end of the manual.

Specifications

MODEL 3E358A

BTU Rating	350,000 per hour
Air delivery	900 SCFM
Voltage	120, 60 Hz, 1 phase
Amperes: Starting	28.0
Running	7.1
Fuel	Kerosene or No. 1 fuel oil
Fuel tank capacity	30 U.S. gallons
Nozzle	2.50 GPH 70° hollow cone
Motor	1/3 HP @ 1725 RPM
Weight: Empty	180 lbs.
Full tank	390 lbs.
Pump pressure	100 psi

MODEL 3E359A

BTU rating	600,000 per hour
Air delivery	2200 SCFM
Voltage	120, 60 Hz, 1 phase
Amperes: Starting	38.0
Running	11.5
Fuel	Kerosene or No. 1 fuel oil
Fuel tank capacity	36 U.S. gallons
Nozzle	4.00 GPH 80° hollow cone
Motor	1/2 HP @ 1725 RPM
Weight: Empty	285 lbs.
Full tank	550 lbs.
Pump pressure	110 psi

General Safety Information

WARNING:

- **IMPORTANT: READ AND UNDERSTAND INSTRUCTION MANUAL BEFORE STARTING OR SERVICING!**
- **IMPROPER USE OF THIS HEATER CAN RESULT IN SERIOUS BODILY INJURY DUE TO HAZARDS OF FIRE OR EXPLOSION, CARBON MONOXIDE POISONING, BURN, AND ELECTRICAL SHOCK.**
- **USE ONLY KEROSENE OR NUMBER 1 FUEL OIL. NEVER BURN GASOLINE, NAPHTHA, PAINT THINNERS, ALCOHOL OR OTHER VOLATILE FUELS!**
- **USE ONLY IN AREAS FREE OF FLAMMABLE VAPOR OR HIGH DUST CONTENT. NEVER USE HEATER WHERE GASOLINE, PAINT THINNER OR OTHER HIGHLY FLAMMABLE VAPORS ARE PRESENT.**
- **MINIMUM CLEARANCE FROM ANY COMBUSTIBLE MATERIAL: 8 FEET FROM HOT AIR OUTLET AND 4 FEET FROM THE TOP AND SIDES.**
- **FILL FUEL TANK OR MOVE HEATER ONLY WHEN HEATER IS UNPLUGGED.**
- **NEVER USE HEATER IN LIVING OR SLEEPING AREAS.**
- **USE ONLY IN WELL VENTILATED ROOMS. PROVIDE VENTILATION OF AT LEAST 3 SQUARE FEET FOR EACH 100,000 BTU OF RATING. (FOR EXAMPLE, A 30,000 BTU HEATER WOULD REQUIRE A TWO FOOT WIDE WINDOW RAISED SIX INCHES.)**
- **WHEN USED WITH A THERMOSTAT, HEATER MAY START ANYTIME!**
- **KEEP CHILDREN AWAY FROM HEATER AT ALL TIMES—NEVER LEAVE A HEATER PLUGGED IN WITHOUT AN ADULT PRESENT IF CHILDREN ARE LIKELY TO BE PRESENT.**
- **USE ONLY WITH ELECTRICAL VOLTAGE AND FREQUENCY SPECIFIED ON MODEL PLATE.**
- **USE ONLY A PROPERLY GROUNDED THREE-WIRE EXTENSION CORD.**
- **DO NOT MOVE, HANDLE OR SERVICE WHILE HOT OR BURNING.**
- **USE ONLY IN ACCORDANCE WITH LOCAL ORDINANCES AND CODES.**
- **NEVER ADD DUCT WORK TO FRONT OF HEATER.**
- **SAFETY REQUIREMENTS AND MODEL PLATE DATA COMPLY WITH THE AMERICAN NATIONAL STANDARDS INSTITUTE SAFETY REQUIREMENTS, ANSI A 10.10-1981.**

Assembly

- Remove the heater from its shipping container and take off any protective packing material which may be applied to it.
- Check the heater for possible shipping damage. If any is found, IMMEDIATELY notify the agent of the carrier which delivered the heater to you and make out a claim for the damage.
- Fill the fuel tank with the proper fuel.
NOTE: If the heater is used at below zero temperatures, the fuel may congeal. To prevent this, before starting move heater into a warmer environment until fuel flows freely.
- Use heater only with adequate ventilation. Provide 3 square feet of ventilation for each 100,000 BTU of rating. Do not use this heater as a source of heat in sleeping quarters.
- Use only kerosene or No. 1 fuel oil; do not use No. 2 or heavier fuel oil as they contain tars which will contaminate the heater. DO NOT USE GASOLINE: IT IS VOLATILE AND DANGEROUS.
- Use the heater only on the electrical power specified on the instruction plate.
- Plug the heater into a grounded receptacle or use a grounding adapter. Be sure the heater is grounded whenever it is in operation and whenever you are working on or near it.
- Minimum clearance from any combustible material: 8 feet from hot air outlet and 4 feet from top and sides.
- DO NOT use the heater in the presence of flammable vapors such as paint, gasoline, or solvents.
- Never add fuel while the heater is operating.
- Keep the air inlet and discharge areas free of loose materials and any obstructions that would hinder the free flow of air into and out of the heater.

NOTE: The motor contains a manual reset overload protector. If this should stop the motor due to low voltage or overload, the motor can be re-started by pressing the red button. Be sure to disconnect the power cord before opening the heater or checking the motor, because the heater may start at any time.

Installation

- Plug the heater into an electrical outlet of 120 volt 60 cycle (Hertz).
- Do not use a power source other than that specified on the nameplate. It is important to use extension cords of the right size if the heater is to be operated at a distance from the electrical source.
- The following table shows the minimum recommended wire sizes for various lengths of extension cords. This wire size is calculated to assure that adequate voltage reaches the heater. Use of a smaller wire size than those recommended will result in slow starting and may result in malfunction of electrical components.

RECOMMENDED WIRE SIZES

LENGTH OF CORD (FEET)	200	100	50
MINIMUM WIRE SIZE (AWG)	8	10	12

Operation

Operation of the heater involves four simple systems:

- Fuel System.** A gear-type fuel pump attached to one end of the motor shaft delivers fuel at 100/110 PSI from the fuel tank through a filter and a solenoid valve to the nozzle, which forces it into the combustion chamber in a fine spray.
- Air System.** A fan attached to the other end of the motor pushes air through the heater. Part of the air enters the combustion chamber and mixes with the atomized fuel to form a combustible mixture. The rest of the air passes over and around the combustion chamber. At the front of the heater it mixes with the hot air coming from inside the combustion chamber. This results in a jet of clean, heated air flowing out of the front of the heater.
- Ignition System.** A transformer provides high voltage to a spark plug which extends through the burner head into the combustion chamber. A constantly firing spark from the spark plug ignites the mixture of fuel and air.
NOTE: The installation of this unit shall be in accordance with the regulations of the authorities having jurisdiction.
- Control System.** The control system is actuated by a light sensing, instantly reacting cell used in conjunction with the safety control to initiate a safety shutdown in the event of ignition or flame failure. In addition, the control system provides a period of blow operation after normal shutoff to purge and cool the combustion chamber.
- A thermostat, mounted on the heater, will operate it in response to the temperature setting provided that the setting is higher than the surrounding air temperature.

- Starting.
 - Plug heater into adequate electrical outlet receptacle.
 - Set the thermostat dial to the desired temperature. Operation from this point on is automatic.
- Stopping.
 - Turn thermostat to lowest temperature setting.
 - You can also stop the heater temporarily by setting the thermostat to a temperature lower than the surrounding air.
 - The heater flame will go out immediately, but the thermal switch will keep motor operating long enough to enable the air flow from the fan to cool the combustion chamber.
 - Do not unplug the heater as this deprives it of the purge (cooling) cycle.
 - Stop the heater by unplugging it only after it has completed its purge (cooling) cycle.

CAUTION: The heater should never be unplugged while in operation because this could cause damage to heater. The heater should not be restarted until the combustion chamber has cooled.

Maintenance (Continued)

6. If the control fails to shut down the heater, it is defective and must be replaced.
7. After replacing control system components, test fire the heater to make sure it will function properly. If it does not, check all wiring connections according to the wiring diagram, Figure 2. Repeat the testing procedure if necessary.

TUNE UP

To keep your heater in top operating condition, perform the following services at the start of each heater season then at the interval specified below:

CLEAN AND/OR REPLACE FUEL FILTER

Clean at least twice a season. More often if heater performance indicates the need. Replace if damaged.

CLEAN FAN

Clean fan after every 500 hours of operation. Clean more frequently if heater is operating in dusty areas or if there is a build-up of dirt on the blades.

REPLACE BURNER NOZZLE

Replace nozzle at least once during the heater season or more often if heater performance indicates the need.

CLEAN AND ADJUST SPARK PLUG

After every 300 hours of operation, clean and adjust spark plug electrodes. Adjust gap or replace the plug if electrodes have been burned, eroded or carboned.

CLEAN PHOTO CELL

Clean the photo cell face with a soft cloth at least once during the heater season. If cell face tends to soot up, check with your nearest service station to determine the cause.

FUEL PUMP MAINTENANCE AND SERVICE

1. To check pressure, remove the hex head pipe plug from the port marked gauge on the fuel pump and install a pressure gauge.

2. If the pressure gauge does not read the correct pressure, plus or minus 5 PSI, when the motor is running and pumping fuel, adjust the pump.
3. Adjust the pressure on the side of the pump body marked pressure adjustment. To increase the fuel pressure, turn the slotted screw inside the port clockwise. To decrease the fuel pressure, turn the screw inside the port counterclockwise. After completion of the adjustment, remove the gauge and install the plug into the fuel pump.
4. If the fuel pressure cannot be adjusted, replace the pump.

STORAGE**CAUTION: Drain all fuel from tank before storing.**

1. Drain all fuel from fuel filter, lines and pump. Clean and flush fuel filter with clean fuel.
2. Drain the fuel tank completely and add approximately one gallon of clean kerosene. Attach the fuel cap and move the heater forwards and backwards to circulate the fuel. Remove the drain plug and drain tank completely.
3. Replace drain plug and properly dispose of the old and dirty fuel.
4. Fill the fuel tank with 2 gallons (350,000 BTU/HR), or 3 gallons (600,000 BTU/HR) of kerosene or No. 1 fuel oil. Replace fuel cap.
5. Operate unit for 5 minutes.
6. Remove drain plug and drain tank completely.
7. Replace drain plug and properly dispose of old and dirty fuel.
8. Store heater in a dry location free of corrosive fumes and dust.
9. Do not store kerosene over summer months for next heating season usage.

LIMITED WARRANTY

DAYTON ONE-YEAR LIMITED WARRANTY. High Pressure oil-fired heaters, Models 3E358A and 3E359A, are warranted by Dayton Electric Mfg. Co. (Dayton) to the original user against defects in workmanship or materials under normal use for one year after date of purchase. Any part which is determined by Dayton to be defective in material or workmanship and returned to an authorized service location, as Dayton designates, shipping costs prepaid, will be, as the exclusive remedy, repaired or replaced at Dayton's option. For limited warranty claim procedures, see PROMPT DISPOSITION below. This limited warranty gives purchasers specific legal rights which vary from state to state.

LIMITATION OF LIABILITY. To the extent allowable under applicable law, Dayton's liability for consequential and incidental damages is expressly disclaimed. Dayton's liability in all events is limited to, and shall not exceed, the purchase price paid.

WARRANTY DISCLAIMER. Dayton has made a diligent effort to illustrate and describe the products in this literature accurately; however, such illustrations and descriptions are for the sole purpose of identification, and do not express or imply a warranty that the products are merchantable, or fit for a particular purpose, or that the products will necessarily conform to the illustrations or descriptions.

Except as provided below, no warranty or affirmation of fact, expressed or implied, other than as stated in "LIMITED WARRANTY" above is made or authorized by Dayton.

PRODUCT SUITABILITY. Many states and localities have codes and regulations governing sales, construction, installation, and/or use of products for certain purposes, which may vary from those in neighboring areas. While Dayton attempts to assure that its products comply with such codes, it cannot guarantee compliance, and cannot be responsible for how the product is installed or used. Before purchase and use of a product, please review the product application, and national and local codes and regulations, and be sure that the product, installation, and use will comply with them.

Certain aspects of disclaimers are not applicable to consumer products; e.g., (a) some states do not allow the exclusion or limitation of incidental or consequential damages, so the above limitation or exclusion may not apply to you; (b) also, some states do not allow limitations on how long an implied warranty lasts, consequently the above limitation may not apply to you; and (c) by law, during the period of this Limited Warranty, any implied warranties of merchantability or fitness for a particular purpose applicable to consumer products purchased by consumers, may not be excluded or otherwise disclaimed.

PROMPT DISPOSITION. Dayton will make a good faith effort for prompt correction or other adjustment with respect to any product which proves to be defective within limited warranty. For any product believed to be defective within limited warranty, first write or call dealer from whom product was purchased. Dealer will give additional directions. If unable to resolve satisfactorily, write to Dayton at address below, giving dealer's name, address, date and number of dealer's invoice, and describing the nature of the defect. Title and risk of loss pass to buyer on delivery to common carrier. If product was damaged in transit to you, file claim with carrier.

Troubleshooting Chart

SYMPTOM	POSSIBLE CAUSE(S)	CORRECTIVE ACTION
Odor and smoke from heater	<ol style="list-style-type: none"> 1. Air leak in suction system 2. Low pump pressure 3. Dirty filter 4. Dirty burner nozzle 5. Low voltage causing motor to operate below rated speed 6. Water deposits suspended in fuel 7. Low motor RPM 	<ol style="list-style-type: none"> 1. Check filter for leakage. Tighten all fuel line connections. 2. Adjust pump pressure. 3. Clean the filter element and filter bowl. 4. Clean the burner and replace nozzle. 5. Voltage at heater should be not less than 90% of rated voltage. (108 volts for 120-volt heaters.) 6. Wait for water to settle out after filling tank; then drain tank and refill with fuel containing no water. 7. Check voltage, if OK, check motor RPM. Motor must run at least 1700 RPM on proper voltage. If not, replace motor.
Failure to start (Motor does not start when thermostat is set to call for operation)	<ol style="list-style-type: none"> 1. Proper power not reaching heater 2. Loose electrical connections 3. Control not activated 4. Motor overload protector tripped 5. Thermostat defective 6. Safety control defective 7. Damaged power relay 	<ol style="list-style-type: none"> 1. Check that heater is connected to a live power line with good fuses, and that the voltage at the heater is correct. 2. Check; tighten if necessary. 3. Press and release reset button on control. 4. Check for cause of motor overload. Correct cause or replace motor. 5. Replace thermostat. 6. Replace safety control. 7. Replace power relay.
Heater will not ignite (Motor runs when thermostat is set to call for operation.)	<ol style="list-style-type: none"> 1. Fuel tank empty 2. Spark plug dirty or not properly gapped 3. Solenoid valve not opening 4. Improperly wired after servicing 5. Pump not providing fuel, or providing fuel at too-low pressure 6. Water in fuel 	<ol style="list-style-type: none"> 1. Fill fuel tank. 2. Reset spark plug after cleaning, according to dimensions in Figure 4. 3. If electrical connections to solenoid valve are good, replace solenoid valve. 4. Check wiring according to Wiring Diagram, Figure 2. 5. Check pump output pressure; adjust if necessary; replace pump if adjustment cannot be made or will not hold. Filter element needs cleaning. 6. Drain tank, rinse with clean fuel; clean filter element and filter housing. Refill with clean fuel.
Nuisance trip-outs	<ol style="list-style-type: none"> 1. Open or damaged photocell 2. Defective safety control 3. Defective fan switch 	<ol style="list-style-type: none"> 1. Replace photocell. 2. Replace safety control. 3. Replace fan switch.

WIRING DIAGRAM

Figure 2

Operation (Continued)**OPERATING SEQUENCE**

The following is a description of the normal automatic operating sequence of the heater (See the Wiring Diagram, Figure 2).

1. The heater is turned on by the thermostat automatically in response to a temperature setting of the dial, provided the setting is higher than the surrounding air temperature.
2. When operation is called for, the transformer and the motor, fan and fuel pump start operating immediately.
3. After fan reaches running speed, the solenoid valve will open. This allows fuel to flow to the nozzle. The heater will then ignite.
4. After about 2 minutes, the purge circuit is energized.
5. When the thermostat setting equals the surrounding air temperature or is turned to the COOLEST position, the solenoid valve shuts off the flow of fuel to the nozzle, and the fire goes out immediately. The fan continues to run, purging the heater.
6. When the combustion chamber cools, the thermal switch changes back to its starting position, shutting off the motor.
7. If, for some reason, the fire goes out before the thermostat is satisfied, or if the heater fails to ignite when operation is called for, the safety control will shut off the heater within 10-40 seconds. If this should occur, unplug the heater, and determine the cause of the shutdown. Correct the cause then press the reset button on the safety control and restart the heater.

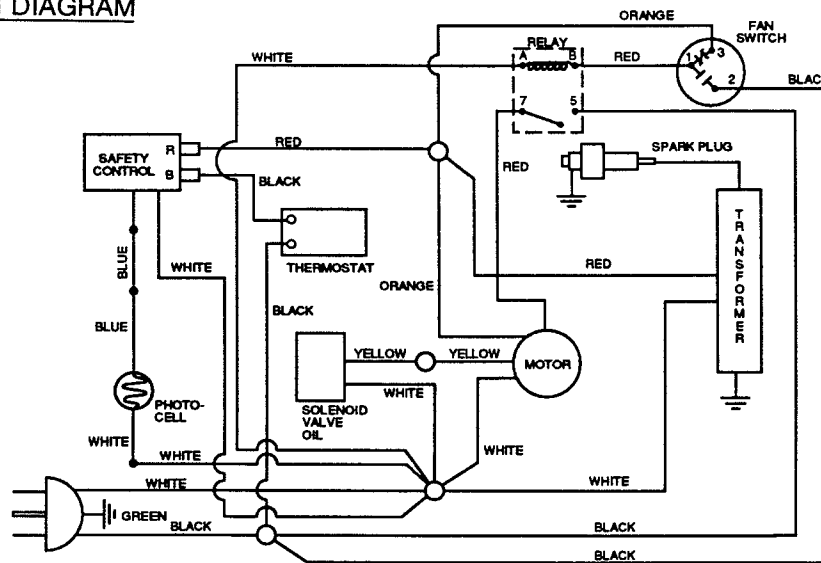
Maintenance

Maintenance consists of the operations the owner or user of the heater can perform to keep the heater operating properly. If routine maintenance fails to return a heater to top-operating condition, refer to the Trouble Shooting Chart. Keep the heater clean to reduce the need for extensive maintenance or repair.

FUEL SYSTEM MAINTENANCE

1. Use the cleanest fuel available. Dirt and water in the fuel will clog the filter, and may cause the heater to burn with an odor. If there is excessive water in the fuel, the flame may go out. Every 250 hours (or more often) drain the tank and rinse it with clean, "dry" fuel (no water in it). Then refill with clean fuel.
2. Every 250 hours of operation, unscrew the filter bowl to remove the filter element. Rinse the filter element and bowl in clean kerosene and wipe dry with a clean cloth to remove all accumulated dirt.
3. Check the fuel line connections occasionally to be sure they are tight.
4. If the solenoid valve should begin to stick open or closed, replace it.

AIR SYSTEM MAINTENANCE

1. If the heater is used in dusty or dirty air, the fan blades may in time build up enough dirt to reduce the over-all efficiency of the heater. Inspect them occasionally, and wipe off any loose dirt. Use a rag moistened with kerosene or non-flammable cleaning solvent to get stubborn dirt off the blades.

Maintenance (Continued)

2. Keep the deflector plate and the air passages around the burner head free from dirt and trash.

BURNER MAINTENANCE AND SERVICE

WARNING: BE SURE THE HEATER IS DISCONNECTED FROM THE POWER LINE BEFORE OPENING UP AND WORKING IN THE BURNER AREA.

1. For access to the nozzle (Figure 3), remove the upper shell. Disconnect the fuel line, spark plug lead. Remove the screws attaching the burner head assembly to remove it from the combustion chamber.
2. **DO NOT** attempt to clean the nozzle. Replace any nozzle that is badly carboned or dirty. When replacing the nozzle, the tightness torque should be 80 to 110 inch-pounds.

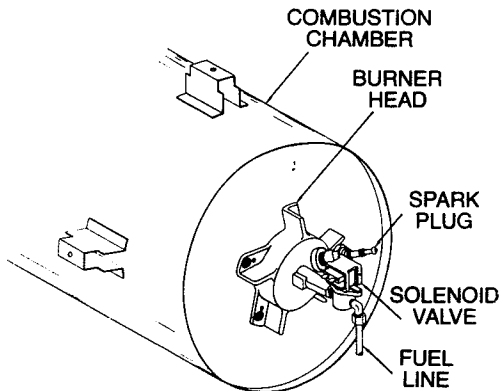

Figure 3

CAUTION: Never use a drill, wire or any other tool in the nozzle orifice as this will damage the nozzle and require its replacement. While it is out of the burner, guard the nozzle from damage or dirt. This is important. If the nozzle is damaged, replace it.

SPARK PLUG

WARNING: BE SURE THE HEATER IS NOT PLUGGED INTO THE OUTLET. THE SPARK PLUG WIRE CARRIES HIGH VOLTAGE DURING HEATER OPERATION.

1. Disconnect the spark plug wire.
2. Remove the spark plug from the burner head, and check the gap between the electrodes, as shown in Figure 4.
3. Adjust the gap by bending the outside electrodes where shown in Figure 4. If you do not install the plug immediately, protect it from damage until it is re-installed.
4. Install the plug into the burner head, if no further burner head maintenance is required. Make sure the spark plug is seated firmly in the burner head.

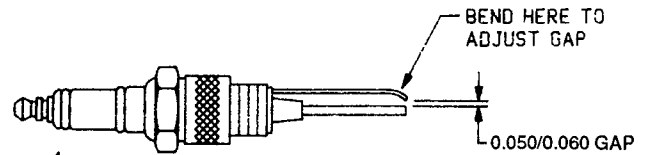

Figure 4

SAFETY CONTROL CIRCUIT TESTING

NOTE: The following testing procedures should be performed only if trouble indicates the safety control circuit may be at fault.

1. Unplug the heater cord.
2. Make certain that the reset buttons on the motor and the control are pressed in. Set the thermostat to a temperature above the temperature of the surrounding air.
3. Remove the wiring cover. Disconnect the blue photo-cell wire from the safety control. Connect the blue wire from the safety control together with the white wires using a wire nut to make the connection. **CAUTION:** Insulate all bare wires before connecting heater to power supply. Plug heater into 120V AC 60Hz power supply. If the reset button on the safety control pops out and the heater shuts off, the control is defective and must be replaced. If the heater continues to run for 5 minutes turn the thermostat to the "COOLEST" position. Wait 10 minutes to allow the heater to complete its purge (cooling) cycle. Unplug the heater. Separate the blue wire from the wire nut connection with the white wires. **CAUTION:** Insulate all bare wires before connecting heater to power supply. Plug heater into 120V 60Hz power supply. The control should trip out in 10-40 seconds. When the control trips out, the flame will disappear, but the motor will continue to run to purge heat from the heater. If heater continues to burn, first check solenoid valve. If solenoid valve functions normally, the control is defective and should be replaced.
4. If the control functions normally from the tests above, there are two possible causes for the problem. The heater does not have a well established flame pattern or the problem is in the photocell. The photocell is a light sensitive device that changes resistance from a high resistance (greater than 100,000 ohms), when no flame is sensed, to a low resistance (less than 3000 ohms) when the flame is sensed. Connect an ohmmeter across the photocell leads and check for this change in resistance. If the ohmmeter reads zero or open, the cell should be checked for dirt on the face or shorted leads. If the face of the photocell is dirty, clean with soft cloth and replace. Check for the resistance change in the photocell from no flame to flame. If the cell still reads zero or open, check the wiring from one end to the other for opens and across the leads for shorts. If no problem is found replace the cell and check once again for the resistance change.
5. If the photocell and safety control function properly, the problem is that the heater is not burning properly.

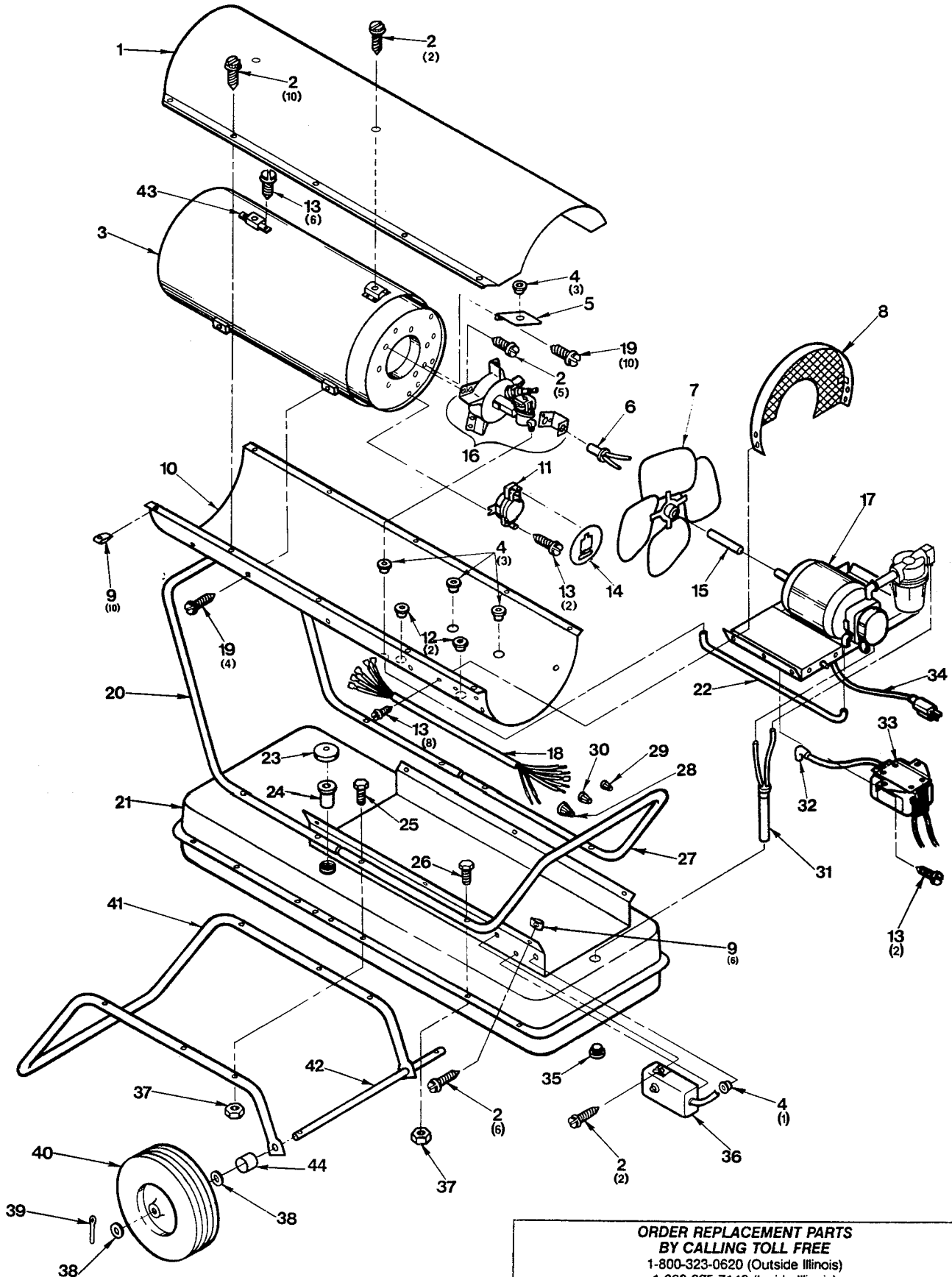

Figure 5—Replacement Parts Illustration for Model 3E358A

**ORDER REPLACEMENT PARTS
BY CALLING TOLL FREE**
 1-800-323-0620 (Outside Illinois)
 1-800-225-7149 (Inside Illinois)

Please provide following information: Address parts correspondence to:

- Model Number
- Serial Number (if any)
- Part Description and Number as shown in Parts List.

Dayton Electric Mfg. Co.
 1250 Busch Parkway
 Buffalo Grove, IL 60089

Replacement Parts List for Model 3E358A

REF. NO.	DESCRIPTION	PART NO.	QTY.
1	Upper shell	M50060AZ	1
2	Screw, #10-16 x 1/2"	M11084-27	25
3	Combustion chamber and shield	M50542-01	1
4	Bushing	M30865-02	7
5	Air deflector	M50086	5
6	Photocell assembly	M16656-4	1
7	Fan	M50121	1
8	Fan guard	M50097-01AA	1
9	Clip nut	M11271-6	16
10	Lower shell	M50061AZ	1
11	Fan switch	M51336-02	1
12	Bushing	M50104-02	2
13	Screw, #10-16 x 3/8"	M11084-26	18
14	Fan switch cover	M51160-01	1
15	Sleeve	M50278	1
16	Burner head assembly (see Figure 8 for details)	†	1
17	Motor & pump assembly (see Figure 7 for details)	†	1
18	Wire harness	097494-01	1
19	Screw, #12-14 x 1/2"	M11084-3	14
20	Front handle	M50062-03	1
21	Fuel tank	098513-05	1
22	Fuel line	M50295	1
23	Fuel cap	097702-01	1
24	Filter neck screen	M18053	1
25	Screw, #1/4-20 x 2 1/4"	HC4-18C	6
26	Bolt, #1/4-20 x 1 1/2"	M51043-01	2
27	Rear handle	M50062	1
28	Wire connector (large)	*	1
29	Wire connector (medium)	*	2
30	Wire connector (small)	*	4
31	Fuel line assembly	M50115-01	1
32	Ignition boot	M50050	1
33	Transformer, 5000 volt	098557-03	1
34	Power cord	098219-08	1
35	Drain plug	M27417	1
36	Thermostat	097513-02	1
37	Nut, hex lock 1/4-20	NTC-4C	8
38	Flatwasher, 5/8"	WP-10C	4
39	Cotter pin, 5/32 x 1 1/4"	C5-10C	2
40	Wheel	M50389	2
41	Wheel support frame	M50063	1
42	Axle	M18774	1
43	Deflector brace	M50274	3
44	Wheel spacer	M50296	2
Δ	General information decal	097500-03	1

(*) Standard hardware item, available locally.

(†) Not available as complete assembly.

(Δ) Not shown

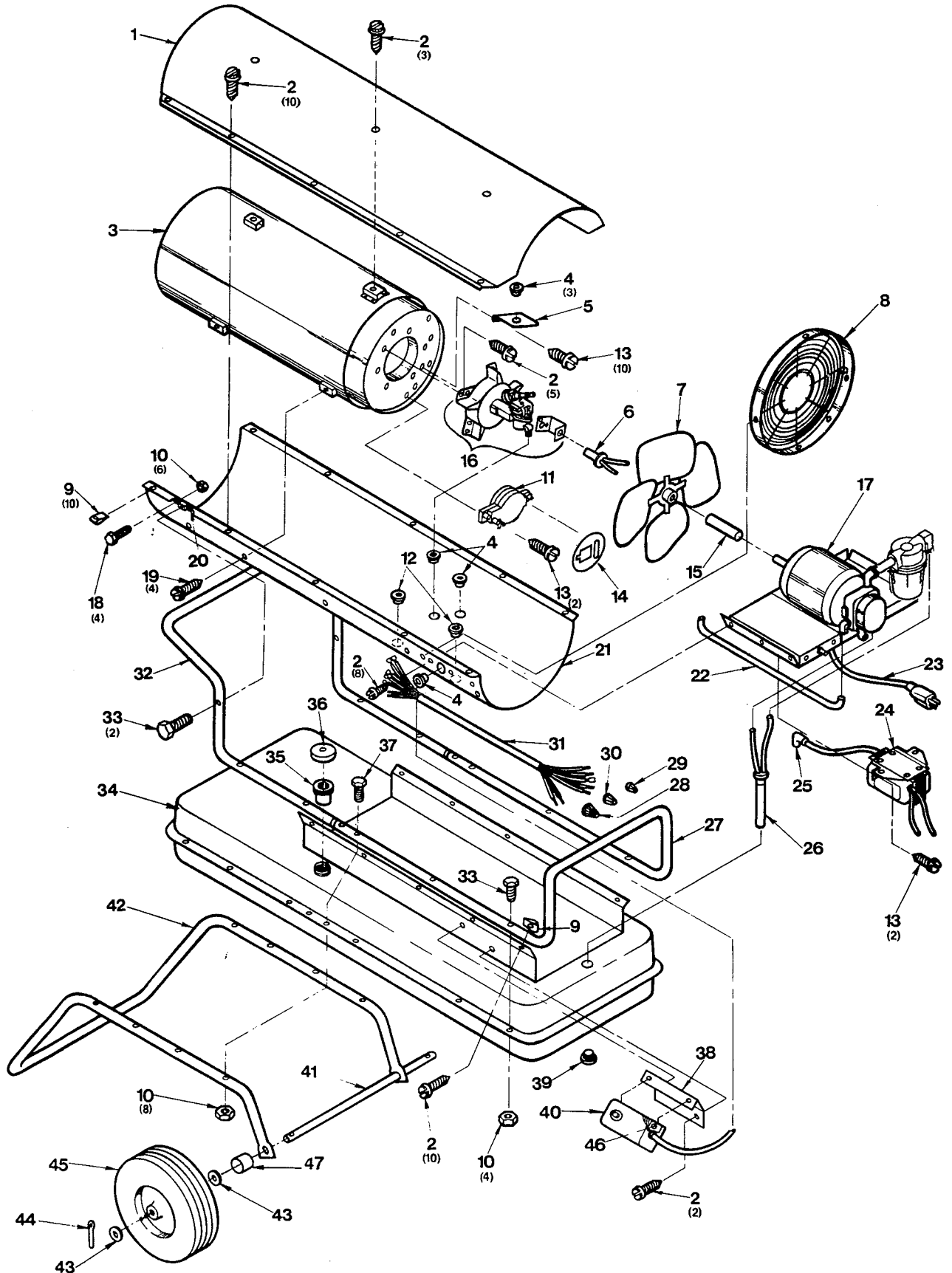

Figure 6—Replacement Parts Illustration for Model 3E359A

Replacement Parts List for Model 3E359A

REF. NO.	DESCRIPTION	PART NO.	QTY.
1	Upper shell	M50167AZ	1
2	Screw, #10-16 x 1/2"	M11084-27	38
3	Combustion chamber and shield	M50543-01	1
4	Bushing	M30865-02	6
5	Air deflector	M50157	5
6	Photocell assembly	M16656-4	1
7	Fan	M50194	1
8	Fan guard	M50186-01AA	1
9	Clip nut	M11271-6	18
10	Hex nut, #1/4-20	NTC-4C	18
11	Fan switch	M51336-02	1
12	Bushing	M50104-02	2
13	Screw, #10-16 x 3/8"	M11084-26	14
14	Fan switch cover	M51160-01	1
15	Sleeve	M50278	1
16	Burner head assembly (see Figure 8 for details)	†	1
17	Motor & pump assembly (see Figure 7 for details)	†	1
18	Screw, 1/4-20 x 3/8"	HC4-3C	4
19	Screw, #12-14 x 1/2"	M11084-3	4
20	Support bracket	M50388AZ	2
21	Lower shell	M50168AZ	1
22	Fuel line	M50119-01	1
23	Power cord	098219-08	1
24	Transformer, 5000 volt	098557-03	1
25	Ignition boot	M50050	1
26	Fuel line assembly	M50115-02	1
27	Rear handle	M28872-01	1
28	Wire connector (large)	*	1
29	Wire connector (medium)	*	2
30	Wire connector (small)	*	4
31	Wire harness	097494-02	1
32	Front handle	M50224	1
33	Bolt, #1/4-20 x 1 1/2"	M51043-01	6
34	Fuel tank	098513-07	1
35	Filter neck screen	M18053	1
36	Fuel cap	097702-01	1
37	Screw, #1/4-20 x 2 3/4"	HC4-22C	8
38	Thermostat bracket	M25121B	1
39	Drain plug	M27417	1
40	Thermostat	097513-02	1
41	Axle	M18774	1
42	Wheel support frame	M28140-02	1
43	Flatwasher, 5/8"	WP-10C	4
44	Cotter pin, 5/32 x 1 1/4"	C5-10C	2
45	Wheel	M50389	2
46	Screw, #6-32 x 3/8"	RCI-3C Δ	2
	Internal lockwasher No. 6	WLI-1C Δ	2
	Nut, 6-32	NPC-1C Δ	2
47	Wheel spacer	M50296	2
Δ	General information decal	097533-03	1

(*) Standard hardware item, available locally.

(†) Not available as complete assembly.

(Δ) Not shown

**Replacement Parts List for Models 3E358A & 3E359A
Motor and Pump Assembly**

REF. NO.	DESCRIPTION	PART NO.	QTY.
1	Wiring cover	097495-01AA	1
2	Screw, 5/16-24 x 5/16"	HF5-5C	4
3	External lockwasher 5/16	WLE-5	4
4	Screw, #10-16 x 3/8"	M11084-26	3
5	Motor (Model 3E358A)	097508-01	1
	Motor (Model 3E359A)	097531-01	1
6	Flange clamp (holds pump to motor)	M50116	1
7	Motor support (Model 3E358A)	097506-01AA	1
	Motor support (Model 3E359A)	097505-01AA	1
8	Street elbow	57413	2
9	Pipe nipple	M17499-2	1
10	Fuel filter assembly	098102-01	1
	Filter element (inside fuel filter assembly, includes rubber gaskets)	098103-01	1
11	90° male elbow	M50114-02	1
12	Compression elbow	M50297	1
13	Straight fitting	M50113-02	1
14	Fuel pump	M50065	1
15	Lockwasher 5/16	WLM-5	4
16	Hex nut 5/16-24	NPF-5C	4
17	Safety control	M50671-01	1
18	Power relay	097491-01	1
19	Shorty bushing	M50104-02	3
20	Screw, #6-32 x 3/8"	M10908-2	2
21	Strain relief bushing	M11143-1	1
22	Screw, #8-32 x 1/4"	097211-01	1

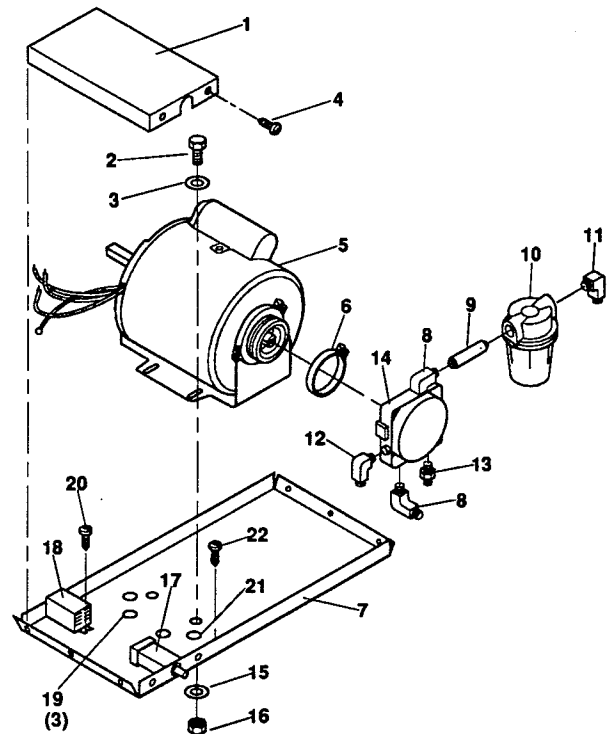

Figure 7—Replacement Parts Illustration for Motor and Pump Assembly

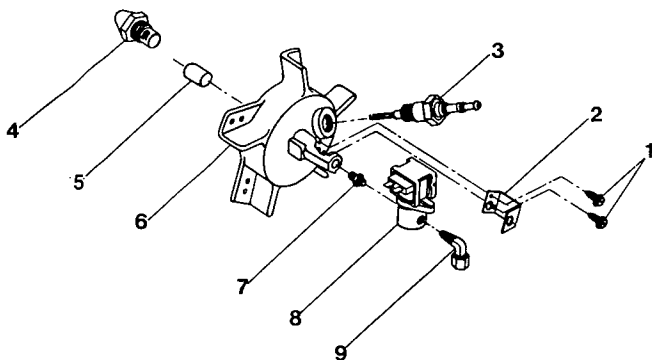

Figure 8—Replacement Parts Illustration for Burner Head Assembly

Replacement Parts List for Models 3E358A & 3E359A Burner Head Assembly

REF. NO.	DESCRIPTION	PART NO.	QTY.	REF. NO.	DESCRIPTION	PART NO.	QTY.
1	Screw, #6-32 x 3/8"	M10908-2	2	5	Plug	M51170-01	1
2	Photocell bracket	M50340-02	1	6	Burner head body	M50924-02	1
3	Spark plug	M10962-2	1	7	Straight nipple	69246	1
4	Nozzle (Model 3E358A)	M50112	1	8	Solenoid valve	M50390-01	1
	Nozzle (Model 3E359A)	M30765	1	9	Compression elbow	M50297	1

**ORDER REPLACEMENT PARTS
BY CALLING TOLL FREE**
 1-800-323-0620 (Outside Illinois)
 1-800-225-7149 (Inside Illinois)

Please provide following information: Address parts correspondence to:

- Model Number
- Serial Number (if any)
- Part Description and Number as shown in Parts List.

Dayton Electric Mfg. Co.
 1250 Busch Parkway
 Buffalo Grove, IL 60089

SERVICE RECORD

DATE	MAINTENANCE PERFORMED	REPLACEMENT COMPONENTS REQUIRED