



“TOYUG”

The Other YN-622C User Guide

*YONGNUO YN-622C FLASH CONTROLLER/ TRIGGER SYSTEM
FOR CANON DSLR CAMERAS*

Version 4.09

© Clive D Bolton, 11 December 2014
Tauranga, New Zealand

Declaration of Interest

The author has no association with the manufacturer other than as a paying customer. Some additional samples were received; my thanks to Yongnuo. Testing equipment included EOS 50D, 7D and 6D; Speedlites 580EX II, 430EX II and 550EX; Yongnuo YN-568EX flash, YN-622C and YN-622C-TX triggers.

Copyright

This document is copyright C D Bolton 2012 - 2014 and all moral rights are asserted. It may be shared and quoted freely, but not altered. Many thanks to those who provided information incorporated in it, especially Phil Weston for editorial input. All registered trademarks in this user guide are the property of their respective owners. Specifications and functions may change without notice.

PREFACE

Update – July, 2014

YongNuo released the **YN-622C-TX** on 28 June 2014. This unit provides a more convenient control interface, and a better Groups mode than the 622C's Mix Mode. The YN622C-TX is a self-contained controller for the YN622C receivers. It removes the need to use the camera's External Flash menus for most functions.

Version 4 of TOYUG represents a complete re-organisation, and in many parts a re-write of earlier versions.

In the 21 months since its first release, the YN-622C has shown good reliability and great versatility. There have been firmware and hardware updates to improve performance and compatibility, and to add extensions. My original conclusion still stands.

When YongNuo Photographic released the YN-622C in 2012, it seems that they had more in mind than just the one transceiver (radio in and out) unit. The possibilities have been further expanded by subsequent developments seen in Canon's "RT" technologies, as seen in the 5DIII camera and 600EX-RT flash. The YN-622C-TX makes use of some of these features.

Just announced is a **studio flash (monobloc) with E-TTL** capabilities via a built-in hot-foot for connecting a YN-622C remote. Rated at 300WS, It will integrate fully with the YN-622C system. It even has a port for firmware updates by the user! Power supply requirements presently exclude USA, Canada and Japan: 182-265v AC, 50Hz.

Also, YongNuo have added the ability of the new C-TX to receive commands from the **YN-560-TX** (dedicated controller for the Manual-only YN-560-III flash). The C-TX will then use a "Proxy mode" to forward the commands from the 560-TX to remote 622Cs with mounted Manual or E-TTL flashes.

Part I of this Guide provides the core facts about the original YN622C transceiver and the YN622C-TX Controller, as confirmed by independent testing where possible. Putting them to use is described in Parts II and III. The final Useful Stuff section contains additional helpful information.

Footnote – December, 2014

The world moves on, but the time comes when we do not: I do not have access to cameras from 2012, with their newer protocols, so this guide is becoming dated. My thanks to all the competent and fluent forum contributors, past and future!

Original - August, 2012

(Slightly edited to remove out-dated material)

What we know gets in the way of what we could know.

I have used Canon's External Flash menus for 5 years, appreciating being able to control remote flashes from the camera. Well, sort of. Canon has been using an optical pulse "wireless" command system for off-camera flashes, which works within a limited set of conditions.

Pixel released their King triggers to remove this limit, but their development was truncated. However, kudos to Pixel for pioneering this category of trigger/controller.

Now we have the Yongnuo YN-622C which seems to fulfil the promise of a full implementation of Canon flash technologies over a radio link. It seems that Yongnuo has not only achieved this objective, but has added a wide range of triggering and photographer-friendly capabilities.

The YN-622C is a transceiver type radio device designed to go between a camera and one or more off-camera flashes, to provide:

- E-TTL, FEC & HSS off-camera triggering
- Radio control of off-camera flashes from camera's External Flash menus
- General-purpose triggering

The YN-622C is a tool for both automatic E-TTL flash exposure and Manual power levels. Each method has its place, and photographers who understand the technologies can get predictable results.

One part of Canon's E-TTL is often misunderstood – Ratios. It is more than setting an FEC or EV adjustment on two flash groups. That still leaves distance, height, angle, relative powers, uneven ambient etc that can make a substantial difference. Canon's ratio evaluates the actual contribution to the image of each group of flashes, and sets the level accordingly. It is much more accurate than the EV method. The YN-622C implements the genuine Canon technology in the camera.

Drawbacks:

- The YN-622C does not provide for firmware updates by the user.
- Canon Wireless Master/Slave is not available, being replaced by the 622C procedures.
- The transceiver buttons are hard to find by touch, and are sensitive to accidental changes.
- Canon's original External Flash menus are inconvenient and access is slow.
- Only flashes in group C can be disabled remotely (Canon problem).
- Cannot by itself act as a shutter release.

It is not a significant list.

An examination of the case and internal components reveals a high-quality assembly. The case appears firm. I anticipate a good life expectancy.

Because the YN-622C is designed primarily to implement Canon technologies, a thorough knowledge of both camera and flash manuals is helpful. Each camera model has its own variations.

My verdict: versatile, complex, well-made, suitable for many jobs, and low-priced. Buy it.

CONTENTS

Introduction 2-7

Declaration of Interest
Copyright

Prefaces 3-4

Update – June 2014
Original – August 2012

Contents..... 5-7

Terms and Definitions 8

Part I – The 622C System..... 9-14

622C Flash Controller/Remote . 10-11

Functions, Specifications

622C-TX Flash Controller 12-14

Functions, Specifications

Compatibility 15-18

About Compatibility

Camera Compatibility

Type A – Camera menu Control
Type B – Flash button Control
Type C – Sync Only

Flash Compatibility

Class 1 – Remote E-TTL and Manual
Class 2 – Remote E-TTL, Local Manual
Class 3 – Remote E-TTL, No Manual
Class 4 – No E-TTL, Sync Only
Class 5 – Studio flashes

Getting Started 19-23

1. Prepare the Camera
2. Prepare the Units
3. Reset/Clear to Factory Defaults
4. Check the Firmware, and Versions
5. Instal a 622C or C-TX
6. Configure Transmitter or Controller
7. Mount Flash on a Remote 622C
8. Prepare the 622C Receiver
9. Prepare Flash
10. On-TX Flash
11. Testing the Lighting Setup
12. First Shots

Part II – 622C Transceiver.....25-33

Transmitter Remote/Mix Modes 26

Setting the Mode
Camera Remote Mode
On-Flash Mix Mode

E-TTL Mode 27-28

Type A cameras
Type B cameras
Ratios
Flash Exposure Compensation FEC
Flash Exposure Lock FEL
Flash Exposure Bracketing FEB

Manual Mode 28

Remote Manual Levels
All Flashes (Global setting)
Multiple Receiver Groups
On-flash Manual Levels

Multi (Stroboscopic) Mode..... 29

Shutter Sync Modes 29

First Curtain
Second Curtain
Fast-Shutter Sync
Hi-Speed Sync (HSS)
Super Sync (SS)
Simple Trigger

Camera Features..... 30

Ambient-only Shot
High-speed Continuous Shooting
Live View
Modelling Light

Flash Features..... 30-31

Flash zoom / coverage
Zoom Lock
Zoom and Remote Control
Zoom and Mix Control
LCD Display
Pilot Indicator

Continued...

Part II – 622C continued

Transceiver Features.....31-33

- Saving the Settings**
- AF-Assist Beam**
 - Autofocus Assist
 - Setting Confirmation
- Sleep Wakeup**
- Channel Indicators**
- Transceiver Status Indicator**
 - Power Up / Initialise
 - Standby / Remote – Mix
 - Communicating
 - Low battery indicator
- Group Indicators**
 - Receiver Group
 - Test Firing Group
- Camera Firing Group**

Part III – C-TX Controller.....35-44

C-TX Control Modes 36

- Remote Control
- Local Control
- Base Trigger
- Fuji Cameras

C-TX Interface.....37-38

- The Buttons
- Restore Factory Defaults
- The LCD Display

Indicators

- Status indicator
- Battery Charge indicator
- Access and Visibility

Exposure Modes39-41

- Selecting a Group's settings
- Set Exposure mode

E-TTL Mode

- Set Group FEC
- Set Global FEC
- Using Flash Exposure Lock
- Enable Ratio and Back Lighting
- Enable FEB

Manual Mode

- Set Group Manual Output

Multi Mode

- Enable Multi

Shutter Sync Modes 41

- Set Sync Mode

Camera Features..... 42

- Camera External Flash Menus
- Enable Remote Shutter Release

Flash Features..... 42

- Set Group Zoom

C-TX Controller Features43-46

- Update C-TX Firmware
- Set Channel
- Test communications and flashes
- Set Super Sync Timing
- Using Super Sync
- Enable AF-Assist Beam
- Enable use on non-Canon cameras
- Enable Remote Manual pre-2007
- Enable Free Mask cutout

Useful Stuff..... 47-63

Canon External Flash Menus.... 48-50

- 2007 style menus
- 2012 style menus

Lighting Scenarios 51-54

- E-TTL Ratio
- Manual Levels
- Augmented Ambient**
 - Basic
 - Remotely Adjusting Augmenting Flash
 - Remotely Turning Off Augmenting
 - Using Class 4 Flashes as Augmenting
 - Manual Control of 4 Zones
 - Two-Shooter Setup
- Class 5 Studio Flashes with Cybersync

Suggestions 55-56

- Batteries
- Battery Orientation
- Camera's Custom/My Menu
- Hybrid Mode
- Light Meter Technique
- Mixing with Other Triggers
- Wireless Mode Setting
- Umbrella/Light Stand Mount

Trouble Shooting 57-58

- Aperture not displayed
- Cold Temperatures
- Erratic Behaviour
- External Flash Menu
- E-TTL Over/Under Exposure
- E-TTL Automatic Adjustments
- Fails to Power On
- Firing Groups
- Flash Not Firing
- Flash Emits Pre-flash
- Flash Zoom cannot be set
- Full-power Flash
- Gap between Pre-flash and Main Flash
- Half Shutter
- On-TX Flash Not Firing
- Unable to Set Channels 5-7

Servicing..... 59-62

- AF-Assist Beam
- Hot-Foot
- Solder Joints
- Opening the Case
- Case Repair
- What's Inside the Cases?

Other Resources 63

Sorry – no Index, but use Ctl-F to search

TERMS AND DEFINITIONS

The Devices

622C: An abbreviation for a YN-622C transceiver.

C-TX: An abbreviation for a YN-622C-TX controller. It does not refer to the YN560-TX

Hot-shoe, Hot-foot, Cold-shoe: The hot-shoe is the accessory fitting on top of camera and each transceiver. The hot-foot has contacts and goes into a hot-shoe, e.g. bottom of a flash or transceiver. A cold-shoe holds a hot-foot without making contact with the pins.

Wireless: This term logically includes radio, sound and light transmission communication links. Canon uses "Wireless" for their light-pulse code communications from camera/Master flash to an off-camera slave flash. The 622C cannot send or read light-pulse codes, using radio instead.

Roles

Transmitter (TX): A YN-622C transceiver (first released in August 2012) mounted on the camera's hot-shoe in the role of controller for remote units. (The transmitter will still act as a Remote to another transceiver transmitting on the same channel.)

Remote Receiver (RX): A YN-622C transceiver (first released in August 2012) in the role of a receiver with a remote flash connected by hot-shoe or PC-sync cable.

Controller (C-TX): A YN-622C-TX controller (released in June 2014) mounted on the camera's hot-shoe provides full settings capability in place of the camera menus.

On-TX flash: A hot-shoe flash mounted on the Transmitter. It has some special features. (The C-TX Controller does not have a hot-shoe to mount a flash.)

Modes and Scope

Remote Mode (622C only): Remote control of flashes from the camera.

Mix Mode (622C only): Mixed remote and local (on-flash) control of flashes.

Global: Applying to all groups (A plus B plus C).

Local: Applying to the local device, such as a setting by hand on a flash.

Synchronising Flash with Shutter

Sync: Synchronous firing of flash when the camera's shutter gives the command.

X-Sync: A camera's fastest shutter speed when both curtains are fully open to a flash.

High Speed Sync (HSS): A method of extending flash emission to provide light during shutter speeds faster than x-sync. It involves starting the emission before the curtains are fully open.

Super Sync (SS): YongNuo's technique for using studio flashes/heads at a shutter speed faster than the camera's x-sync.

PART I – THE 622C SYSTEM

622C Flash Controller/Remote **Control by Camera**

622C Functions

Simple to Complex setups

- The minimum setup is two (2x) 622Cs, one on camera as a transmitter, and one under a flash as remote receiver. Any practical number of 622C remotes can be added.
- Lights can be at any angle to the camera, but walls may reduce range.
- Will also sync with most studio flash lighting.

Controller/Trigger Modes

- Full Remote – uses Canon 5-pin hotshoe and camera's built-in External Flash menu.
- Mixed E-TTL and On-Flash Manual – uses Manual settings locally on flash, and the camera's remote. E-TTL, FEC, FEB, etc.
- Either mode can have a flash on the camera's transmitter for ETTL or Manual output levels, but not as "Master".
- Basic Trigger – Uses single-pin hotshoe (non-Canon cameras). An adapter may be needed.

Flash Modes

- E-TTL II, including Flash Exposure Compensation (FEC), Flash Exposure Bracketing (FEB), Flash Exposure Lock (FEL), Group Ratios A:B.
- Manual output levels, including Manual Group (ALL / A:B / A:B:C).
- Multi (stroboscopic).

Sync Modes

- 1st Curtain Sync (1CS); shutter speed up to camera's x-sync.
- 2nd Curtain Sync (2CS), including using HSS with camera's Wireless mode disabled.
- High Speed Sync ("HSS", "FP"). Max. Sync: 1/8000s, depending on camera and flash.
- Super Sync for some non-HSS flashes. The timing of the advanced sync is not adjustable. Max. Sync Speed: 1/8000s, depending on camera.
- The PC-sync port can output any of these syncs to trigger a studio flash.
- Single-contact camera and single-contact flash sync at max. 1/250s.

Extras

- **Reset** to Factory defaults [CH+GP].
- **Focus Assist Lamp.**
- **Remote flash zooming** (Auto, Manual, local Zoom lock).
- **Test-firing** of flashes.
- **Flash-awaking** function, with capable flashes.
- **Modelling Flash.**
- **Live View** triggering.
- **High-speed continuous** shooting triggering, depending on output limits of flash.
- Power supply uses **common AA** (= LR6, MN1500) alkaline or NIMH batteries.

622C Specifications

Standard Pack

- 2 x Transceivers, default mode Remote/Receiver, auto-switching to Transmitter when required. (Some resellers may offer single or multiple units.)
- Quick Start Guide; User Manual

Transceiver Measurements

- 90 x 53 x 25mm (39mm incl. hot-foot).
- 78gm without batteries

Electrical

- Each unit requires 2x AA batteries (1.5v Alkaline or 1.2v NiMH) – not supplied.
- Standby time: 60 hours.
- 6 volts maximum safe trigger voltage on hot-shoe centre pin.
- 300 volts maximum safe trigger voltage on PC-sync port.
- Digital FSK 2.4GHz radio transceiver. Range up to 100m (300ft), 7 channels.

Connectors

- Canon-compatible Hot Foot with locking ring and locating pin, for mounting on camera as a Transmitter.
- Canon-compatible Hot Shoe for mounting a hot-shoe flash, including on Transmitter.
- PC-Sync screwlock socket, sync out only (1CS, 2CS, Super Sync).

Indicators

- Status LED: Red/Yellow.
- 3x Channel LEDs.
- 3x Group LEDs.

Controls

- [On/Off] power switch.
- [CH Set] button selects one of 7 channels
- [GP Set] button selects one of 3 groups
- [Test] button awakens flash and tests communications.
- [CH + GP] clears all settings and restores Factory defaults.

Other fittings

- Red AF-Assist beam (with a non-adjustable angle), enabled only on Transmitter, effective to about 13 ft/4 m.

Provide-your-own extras

- Batteries
- PC-sync cord for studio flashes
- Mini-stand for hotshoe flash
- Cold-shoe for mounting on light-stand.

622C-TX Flash Controller **Control by LCD Display and Camera**

C-TX Functions

Simple or Complex setups

- The controller's LCD menu provides an alternative to the camera's External Flash menus, and enables extensions not provided by Canon.
- The minimum is one C-TX controller on camera, and one remote 622C under flash. Or, add more remote 622Cs and various flashes.
- Lights can be at any angle to the camera, but walls may reduce range.
- Will also sync with most studio flash lighting, including by time-adjusted Super Sync.

Control/Trigger Modes

- Full Remote – Uses Canon 5-pin hotshoe signals.
- Basic hotshoe – Uses single-pin hotshoe (Non-Canon cameras).
- Basic without hotshoe – Uses camera's PC-Sync out connection to C-TX's PC-sync In.

Flash Modes

- Independent Groups (E-TTL + FEC / Manual Levels / Super Sync / Off) mode
- E-TTL global (FEC / Ratio + Backlight / FEB)
- Multi/Stroboscopic global

Independent Group Settings

E-TTL

- E-TTL II with global FEC.
- FEC by each group in E-TTL.

Manual

- Manual flash output levels, 1/1 to 1/128.

Super Sync

- Super Sync – for studio flashes (monolights and pack-and-heads).

Group Off

- Previous setting for group is not remembered.
- The Free Mask feature temporarily sets Groups A and B to off, and uses Group C only to produce a cutout mask, then returns to the previous main settings.

Flash Zoom

- Remote Zoom by Group, including Auto, 24mm – 105mm.
- Local Zoom Lock can over-ride C-TX setting.

Sync Modes

- 1st Curtain Sync; shutter speed up to camera's x-sync.
- 2nd Curtain Sync up to 1/8000s, including with HSS.
- High Speed Sync (HSS or FP); Max. Sync Speed: 1/8000s, depending on camera and flash.
- Super Sync for non-HSS flashes. The timing of the advanced sync is adjustable from 0.0 to 2.0. Max. Sync Speed: 1/8000s, depending on camera. PC-sync port can output 1CS / 2CS / HSS / Super Sync signal to trigger studio flash.
- Single-contact camera and single-contact flash sync at max. 1/250s.

Extras

- **Shutter release**, using a supplied cable from C-TX to camera, and triggered by a 622C.
- **Remote Manual control of Pre-2007 Speedlites** (e.g. 370EX, 550EX, 580EX).
- **FEL E-TTL Flash Exposure Lock**.
- **Firmware updates** user-installable.
- **Reset to Factory defaults**.
- **Auto-Focus Beam**.
- **Test firing**.
- **Flash-awaking** with capable flashes.
- **Remote Zooming** (Auto, Manual, local Zoom lock)
- **Free Mask** auto cutout image
- **Modelling Flash**
- **Live View** triggering
- **High-speed continuous** shooting triggering, depending on limits of flash.
- **Common AA** Alkaline or NIMH batteries, but NOT Lithium.
- **LCD backlight** which lights for a few seconds when any button is pressed.

C-TX Specifications

Standard Pack

- 1 x YN-622C-TX Controller. (Resellers may offer the C-TX with single or multiple 622C Remotes.)
- User Manual with Warranty Card
- Shutter release cables LS-2.5/C1 (= Canon E3) and LS-2.5/C3 (= Canon N3).

Transceiver Measurements

- 90 x 53 x 39mm including the hot-foot.
- 82gm without batteries.

Electrical

- The C-TX requires 2x AA batteries (1.5v Alkaline or 1.2v NiMH) – not supplied.
- Standby time: 120 hours.
- Digital FSK 2.4GHz radio transceiver.
- Range claimed up to 100M. Our tests indicated 50M in enclosed spaces, and 20M in open.

LCD Display

- Displays settings of the controller on the LCD screen.
- Battery Level and low-battery warning.

Connectors

- Canon-compatible Hot Foot with locking ring and locating pin, for mounting on camera as a “Master” Controller.
- PC-Sync screwlock socket for sync-IN only – for triggering the C-TX, e.g. by a light meter, or a camera with no hotshoe. It will NOT trigger a flash.
- Two 2.5mm connectors for Shutter Release cables supplied:
 - LS-2.5/C1 for 60D, 70D and series 400D, 500D, 600D, 1000D
 - LS-2.5/C3 for 40D, 50D, 7D and series 1D, 5D.
- USB Mini-B socket for user to instal Firmware upgrades.

Indicators

- Status LED: indicates when communicating, when triggering and on remote shutter release.

Controls

- [On/Off] power switch.
- “Setting” buttons – multi-purpose selection of values. They have no labels, so in this Guide are called [Up], [Down], [Left], [Right] and [Set]. [Left] and [Right] change values in whole steps, and [Up] and [Down] change in 1/3 steps. [Set] completes some operations.
- [GR/*] button – Group/row selection, and enabling of Free Mask cutout feature.
- [Mode/E-M] button – Flash mode selection, and setting of E-TTL and M parameters.
- [Sync/Fn] button – Sync mode selection, and setting of at least 5 functions.
- [Zoom/CH] button – Setting of Zoom factor by Group, and Radio Channel selection.
- [Test] button - Awakens flash, and tests communications.
- [Clear] - Clears all settings and restores Factory defaults.

Other fittings

- Red AF-Assist beam.
- Two 2.5mm shutter release cables, N3 and E3.(Canon equivalents)

Provide-your-own extras

- Batteries
- PC-sync cord for non-hotshoe camera, etc.
- USB cable for updating firmware (e.g. the Canon camera USB cable).

COMPATIBILITY

The Key

For the YN-622C (and many other triggers) it's about what each camera body provides for digital data in and out through the accessory shoe, and what the flash moves in and out through its hot-foot. These capabilities are set by the manufacturers. However, the 622C can massage the data as it transmits it back and forth, providing numerous functions not provided by Canon.

What's the Problem?

Why are there several "types" of camera and "classes" of flashes? It's due to the historic development of the technologies.

1. There was an Accessory shoe on camera to mount a device, and a centre-pin contact to fire a flash. All settings were made on-flash. The camera did not know what they were.
2. More pins were added, and TTL, A-TTL, E-TTL then E-TTL II were developed as key flash technologies. The camera became increasingly aware of flash settings. Settings were still made on-flash.
3. Canon implemented an off-camera system using a Master flash to drive one or more slaves using light-pulse coding. Communication was one-way. The camera was taught to read the Master flash settings, and act accordingly. FEC was added to the camera. There was no provision on the camera for setting Manual output levels, so there was no need to implement a control path in the flash's hot-foot. Settings were still on-flash. (Class 2 flashes.)
4. A better interface was required, and in-camera. Canon designed the External Flash menus (from 1D-III, March 2007 on) so that the camera could both read and set ALL settings in the flash. This meant that all flash settings needed to be digital (i.e. no positional switches). The only flashes which can be fully controlled by flash menus are ones that have the required communication through the hot-foot. (Class 1 flashes.)
5. The YN-622C was released in August 2012 to replace the light-pulse coding and its limitations. Some functional improvements were added, without over-riding Canon facilities.
6. Some flashes are designed for "I just want a photo in poor light" use, so do not have the means for the user to set output levels manually. They can handle the automatic exposure E-TTL commands through the hot-foot, however. (Class 3 flashes.)
7. Later, after YongNuo had released the YN-622C, Canon released the 5DIII, ST-E3, 1D X and 600EX-RT, which provide two-way radio communication. These also provide new features like mixed firing modes (ETTL/M/Auto), channels 5-15, Wireless IDs and groups D & E. The 622C cannot use these extensions, and the camera must be used in "optical wireless" mode.
8. In June 2014, YongNuo released a YN-622C-TX LCD Controller unit. It provides full control of remote 622Cs by type B cameras, and an alternative control interface for type A cameras.
9. The Canon YN-622C is *NOT* compatible with the Nikon YN-622N. The cameras' code sets are not the same.

CAMERA COMPATIBILITY

Cameras can be put into one of three types for use with the 622C system. The “RT” capable flashes are currently classed as Type A. Both triggers work with all classes of camera and all types of flash. The question is: to what extent?

Key features of the 622C Transmitter are described, then the C-TX additions.

Type A Camera - Menu Control (2007 and on)

EOS
622C Transmitter using class 1 flashes: Remote E-TTL, FEC and Ratios; remote Manual levels; HSS if available; fixed Super Sync; Firing Groups; Zoom Control.
C-TX Controller adds class 2 flashes and: Variable Super Sync; mixed Flash Mode Groups.
1D III, 1Ds III, 1D 4 1DX (except that ETTL + Wireless + Groups B, C = overexposed) 5D II, 5D III 6D, 7D, 7D II 40D, 50D, 60D, 70D 450D, 500D, 550D, 600D, 650D, 700D XSi, T1i, T2i, T3i, T4i, T5i 100D, 1000D, 1100D SL, XS, T3 EOS-M (no AF-beam)

Power Shot
622C Transmitter using class 1 flashes: Remote E-TTL and FEC; remote Manual levels; HSS if available; fixed Super Sync; Zoom Control.
C-TX Controller adds class 2 flashes and: Remote E-TTL Ratios; variable Super Sync; Firing Groups; mixed Flash Mode Groups.
G12, G15, G1X SX20 IS, SX30 IS, SX40 HS, SX50 HS.

Type B Camera – Flash Button Control (prior to 2007)

EOS
622C Transmitter using class 1 flashes: Remote ETTL/FEC, local Manual levels, HSS if available, fixed Super Sync.
C-TX Controller adds class 2 flashes and: Remote ETTL FEB and Ratio; remote Manual levels, Firing Groups, mixed Flash Mode Groups, variable Super Sync.
1D II, 1D II N, 1Ds II, (NOT 1D, NOT 1Ds) 5D 10D, 20D, 30D 300D, 350D, 400D D-Rebel, XT, XTi

Type C Camera – Sync only

- Does not support HSS or E-TTL functions.
- Max speed sync is 1/250s or less.

622C Transmitter and C-TX Controller using all flash classes: A “fire!” synchronised signal
<ul style="list-style-type: none"> • A camera with a standard single-pin hot-shoe. • A camera with a PC-sync-out connection. • A non-Canon ISO multi-pin hotshoe with an adapter to allow only the centre (X-sync) pin to be accessible (e.g. Nikon). • A brand-specific hot-shoe with an adapter to Canon hotshoe (e.g. Sony/Minolta).

FLASH COMPATIBILITY

Flashes can be grouped into five classes.

- The 622C is rated at only 6 volts on the trigger contact of its hot-shoe. The PC-sync connection can withstand 300 volts.

Class 1 Flash – Remote E-TTL; Remote Manual Levels

622C: Set using External Flash menus not the on-Flash buttons.		
C-TX: Set on C-TX, or by External Flash menus. On-flash settings are available for special lighting.		
Brand	HSS	No HSS
Canon	580EX II, 600EX-RT No Multi: 270EX II, 430EX II	
Godox	Ving V860C	
Jessop		No Multi: 360AFDC
Metz	No Multi: 50 AF-1, 58 AF-2	
Neewer	NW680	
Nissin	Di866 II	
Phottix	Mitros	
Yongnuo	YN-500EX, YN-568EX	YN-465, YN-467 II, YN-468 II, YN-565, YN-565 II (YN-467, YN468 ?)

Class 2 Flash – Remote E-TTL; Flash-set Manual Levels

622C Set On-Camera: Sync mode (1CS, 2CS, HSS); E-TTL (FEC, FEB, FEL and Ratio). Set on-flash: Flash mode (E-TTL, M, Multi); Zoom; Manual levels.		
C-TX Set on C-TX: or by External Flash menus For remote Manual levels on Canons, set C.Fn 05 to “On”, and set the mode on Flash to “E-TTL”.		
Brand	HSS	No HSS
Canon	550EX, 580EX. No Multi: 430EX	
Metz	No Multi: 48 AF-1, 48 AF-2, 54mz4 (Mix mode, Wireless disabled)	
Nissin	Di866	Di622 II
Pixel	Mago	
Sigma	No Multi: EF 500, 530, 610 DG Super	
Sunpak		No Multi: Z42X

Class 3 Flash – Remote E-TTL; Manual Levels not provided

622C Set On-Camera: Sync mode (1CS, 2CS, HSS); E-TTL (FEC, FEB, FEL and Ratio). Set on-flash: Flash mode (E-TTL, M, Multi); Zoom.		
C-TX Set on-C-TX: or by External Flash menus For remote Manual levels, set C.Fn 05 to “On”, and set the mode on Flash to “E-TTL”. (Yet to be tested.)		
Brand	HSS	No HSS
Canon	No Multi: 220EX, 270EX, 320EX, 380EX, 420EX	

Class 4 Flash – No E-TTL provided; Flash-set Manual Levels

- Synchronises at up to 1/8000s (Super Sync), limited by camera and studio flash. Otherwise the fastest shutter is 1/250s.
- A hotshoe flash with only the centre pin effective will receive only a 1st Curtain sync signal.
- A flash connected by a PC-sync cable (including through a PC to Hot-shoe adapter) will receive a 1st Curtain, 2nd Curtain or pre-shutter sync signal.

622C No E-TTL; on-flash Manual.	
C-TX Use variable timing Super Sync with fast shutter speeds.	
Brand	Model
Canon	540EZ (updates LCD info.)
MeiKe	940
Vivitar	285, 285HV only if trigger voltage is 6 volts or less.
Yongnuo	YN460, YN460-II, YN560, YN560-II, YN560EX

Class 5 - Studio Flashes: No E-TTL; Sync Only

- A user-supplied PC-sync cable is required between remote 622C and studio flash’s input.

622C Standard Sync and Fixed Super Sync		
C-TX Standard Sync and Variable Super Sync		
Sync mode	Studio flash Model	Shutter
1 st Curtain	Most studio flashes	X-sync and slower
2 nd Curtain	Most studio flashes	1/30s to 1/60s and slower
High Speed Sync	Cheetah CL180. CL360 Godox Wistro AD180, AD360 ProMaster/Mettle D400R	HSS (flat light) above X-sync
Fixed Super Sync	Jinbei Discovery 1200w Pioneer III 600w Calumet Genesis 300B Mettle 600ws	Burn-time adequate, above x-sync
Fixed Super Sync unusable	Alien Bee 400, 800, 1600 Bowens Travelite Einstein E640 Elinchrom D-Lite 2	Burn-time too short
Variable Super Sync	Many studio flashes, and may include “unusable” ones above.	Start of burn time is adjustable

GETTING STARTED

1. Prepare the Camera

- Set the camera to a Creative exposure mode (P, Av, Tv or M), not a Basic mode (Scenic, Sports or Flash-disabled.)
- Set External Flash menu to Flash Firing = Enabled, and Wireless = Disabled.
- Disable Silent Shooting mode.
- Enable AF-Assist Beam (e.g. C.Fn III/5 = 0, Enabled).
- Set AF mode to One-Shot.
- Disable Face Detection mode.

2. Prepare the Units

- Remove the protective film from each 622C's top plate, and/or from the AF-assist beam's red cover.
- Wipe the contacts in both the hot-shoe and the hot-foot to remove oils and other dirt.
- Insert fresh, fully-charged batteries. They are critical. Do not make assumptions.
Recommendation: load all units with good quality (i.e. more expensive) new Alkalines (1.5v) to start with. When all is working well, good quality NiMH (1.2v) can be used. Do NOT use Lithium (1.6v).

3. Reset / Clear to restore Factory Defaults

- The units as delivered may not be in a factory-fresh state, or may be altered accidentally by a user. When first starting to use the units (or if they seem erratic), perform a Factory Defaults reset.

622C Transmitter Reset (Clear)	C-TX Controller Reset (Clear)
<ul style="list-style-type: none"> • Hold down [CH SET] plus [GP SET] at the same time. • Keep holding until the Status indicator has winked red-green alternately 3 times and then stays red. • Release the buttons. • Factory defaults will be restored to: 622C mode = Remote Flash mode = E-TTL Sync mode = HSS. • The C.Fn (AF-Assist Beam) setting is not changed. 	<ul style="list-style-type: none"> • Hold down [MODE] plus [SYNC] at the same time. The display will show only a steady "CLR". • Keep holding until "CLR" winks slowly. • Release the buttons. • The Main screen will appear, showing all the groups in TTL. • Note: Updating the firmware performs this step automatically • If the CLR screen does not appear, navigate back to the Main screen, and try again.

4. Check the Firmware

622C

When first released in 2012, there were two changes in the firmware. One (Sep. 2012) fixed a transmitter mode problem when using 1D series bodies. The other a little later matched a hardware change.

The firmware has been stable since then, and the 622C does not have a user-upgrade facility, so future upgrades are unlikely.

C-TX

Firmware in the C-TX can be updated by the user. Ensure that the unit's Firmware is the latest version.

- A computer-to-USB 2.0 Mini-B cable (e.g. Canon USB cable) is required.
- A Windows computer platform is required.
- See page 43 for full details for downloading and installing firmware updates.

Version History

- 1.00** Pre-release version.
- 1.01** 01/07/14 First commercial release built in. Upgrade required only for pre-release testers.
- 1.02** 11/07/14 Added YN560-TX proxy mode. Improved stability.
- 1.03** 12/07/04 Made backlight/setting time longer. Changed Updater display to UP.
- 1.04** 18/08/14 Improved stability and transmission range.
- 1.05** Fixed 7D HSS problem, and fixed 7D II E-TTL compatibility.
- 1.06** 03/12/14 Improved power supply on some circuit boards. Corrected display errors.

5. Instal a 622C Transmitter or C-TX Controller

- Turn back the hot-foot's locking ring up to the case to fully withdraw the locating pin.
- Mount the unit in the camera's hot-shoe. Use the thumb to press the foot firmly forward.
- Clamp the locking ring onto the hot-shoe. The locating pin will engage.
- Turn on camera and transmitter/controller.
- If the unit is a 622C Transmitter, press half-shutter or open External Flash menus to activate.



6. Configure Transmitter or Controller

Using Type A Cameras

622C	C-TX
<ul style="list-style-type: none"> Keep Transmitter in Remote mode. 	
<ul style="list-style-type: none"> Set a channel for the Transmitter (1 to 4).using the Wireless function menu, or press [CH Set] repeatedly for 1 to 7. 	<ul style="list-style-type: none"> Set a channel (1 to 7) for the Controller using a long-press [Ch], then [Right] or [Left] repeatedly.
<ul style="list-style-type: none"> Leave the default E-TTL settings, or use External Flash menus to set a desired global Flash mode and Zoom setting. 	<ul style="list-style-type: none"> Leave the default E-TTL settings, or use [Mode] and [Zoom] to set group parameters. Use [Gr] to move between groups.
<ul style="list-style-type: none"> With Wireless = Disabled, the firing group is All (A+B+C), and all groups of flashes use the same global settings. 	<ul style="list-style-type: none"> There are three firing groups, and the individual group settings will apply.

Using Type B Cameras

622C	C-TX
<ul style="list-style-type: none"> Enable Mix control mode on the transmitter by pressing ([CH SET] for several seconds. 	
<ul style="list-style-type: none"> Press [CH SET] repeatedly to set the communication channel 1 to 7. 	<ul style="list-style-type: none"> Set a channel (1 to 7) for the Controller using a long-press [Ch] repeatedly.
<ul style="list-style-type: none"> Set on-Flash the required flash mode (E-TTL, Manual), and individual Zooms. Multi mode requires several parameters to be set on-flash. Manual mode requires the output level to be set on-flash. 	<ul style="list-style-type: none"> Use [Mode] and [Zoom] to set group parameters. Use [Gr] to move between groups. Multi mode parameters are set on the C-TX. For remote Manual, set the Flash mode on-Flash to E-TTL, and set the group levels on the C-TX.
<ul style="list-style-type: none"> Press [GP SET] to set the Firing Group to be used. Default is "All", A+B+C. 	<ul style="list-style-type: none"> Use the three Group Mode settings to control which groups fire.

Using Type C Cameras

622C	C-TX
<ul style="list-style-type: none"> Enable Mix control mode on the transmitter by pressing [CH SET] for several seconds. 	<ul style="list-style-type: none"> Set the group mode to Manual by pressing [Gr] for required Group, then [Mode] repeatedly.
<ul style="list-style-type: none"> Press [CH SET] repeatedly to set the communication channel 1 to 7. 	<ul style="list-style-type: none"> Set a channel (1 to 7) for the Controller using a long-press [Ch], then [Right] or [Left] repeatedly.
<ul style="list-style-type: none"> On-flash, set its Flash mode to Manual 	<ul style="list-style-type: none"> On-flash, set its Flash mode to Manual
<ul style="list-style-type: none"> On-flash set the required Manual output. 	<ul style="list-style-type: none"> On-flash set the required Manual output.
<ul style="list-style-type: none"> Set the Firing group(s) for the 622C transmitter. Hold down [Test] and repeatedly press [GP SET] to cycle through the seven groups. When the desired group is shown, release [Test]. Default is "All", A+B+C. 	<ul style="list-style-type: none"> On-C-TX: Use the Group Mode settings to control which groups fire.

7. Mount Remote Flash on a Remote 622C

- Loosen the locking ring or lever on the flash to withdraw the locating pin.
- Mount the flash on the 622C. Press the foot firmly forward to ensure all contacts are secure.
- Tighten the flash's locking ring or lever.
- Mount the 622C direct on a mini stand, or on a light stand using a cold-shoe adapter.

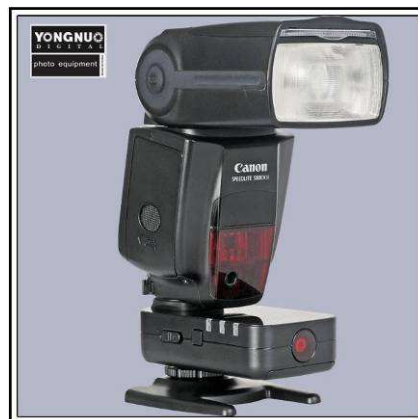

8. Prepare the 622C Receiver

- Slide Receiver power switch to [ON]. The channel and group indicators light briefly. The Status indicator turns steady red. The flash may fire once when turning the 622C on or off.
- Set Receiver to the same channel as the Transmitter, using [CH]. The channel indicator will light for several seconds to indicate the current channel.
- While the channel indicator is lit, quickly press [CH] repeatedly to change the channel.
- Set the Receiver group to A or B or C using [GP] to select the desired Receiver (Lighting) group.

9. Prepare Flash

- Set the Off/Master/Slave switch to Off (if present).
- Turn On the flash.
- Check that the flash indicates it is Ready.
- If using a C-TX with a class 2 flash, set the C-TX's Fn 05 Eco = On and press [Set/OK].
- If using a C-TX with a class 3 flash, set on-flash Mode = E-TTL.
- Press Pilot/Test on the flash; the flash should fire. If it does not, or is slow to recover, replace the flash's batteries.

10. On-TX Flash (622C Transmitter only)

A flash can be installed on the 622C transmitter on top of the camera. It behaves much like a Remote flash, but there are differences:

- Supports E-TTL, Manual levels and Multi (stroboscopic) modes.
- The On-TX flash output settings follow Group A settings.
- The On-TX flash has no channel. It is effectively direct-connected to the camera.
- The zoom setting is NOT controlled by the camera menu. It must be separately set on-flash as Auto or 24mm to 105mm Manual zoom. This is independent of a global zoom setting.
- The on-TX flash may provide an AF-assist beam additional to the Transmitter's AF-assist beam, if that is enabled.

11. Testing the Lighting Setup

The setup can be tested to ensure that all devices are powered up and that the communication is working. In addition, actual lighting outputs can be metered if manual levels are being used.

- The [Test] button can awaken the flashes and test whether they can be triggered. The test works through both the Receiver's hot-shoe and the PC-sync port
- If the flash does not wake, manually awaken it. Use the PC-sync port to connect a flash which does not have the awakening function.
- All the indicators go out when flash fires.

622C Transmitter	C-TX Controller
<ul style="list-style-type: none"> • Any 622C or C-TX can trigger a test on all other powered-up units on the same Channel. 	
<ul style="list-style-type: none"> • Those flashes in the "Test Group" will be awoken on pressing and holding [Test], and fired when released. 	<ul style="list-style-type: none"> • Those flashes in groups whose Mode is not "Off" will be awoken on pressing and holding [Test], and fired when released.
<ul style="list-style-type: none"> • An on-TX flash will also fire if the 622C transmitter's Receiver group (A or B or C) is included in the test group. 	<ul style="list-style-type: none"> • An on-TX flash on another camera using the same channel will fire if the C-TX's group A is enabled.
<ul style="list-style-type: none"> • The Test group is not the same as the Receiver group, or the Firing group which controls ratios and levels. 	<ul style="list-style-type: none"> • The C-TX does not have a Test Group.
<ul style="list-style-type: none"> • To select a Test group, hold down [Test] and repeatedly press [GP SET] to cycle through the seven testing groups. To test all flashes, select All (A+B+C). 	
<ul style="list-style-type: none"> • When the desired Test group is shown, release [Test]. The flashes in the selected group will fire a test flash. 	<ul style="list-style-type: none"> • Press and release [Test]. Flashes in "On" groups will fire a test flash. The Test can be triggered by a hand-held 622C.
<ul style="list-style-type: none"> • The PC-sync port on a 622C is OUT only – there is no light-metering facility. 	<ul style="list-style-type: none"> • A light meter with a PC-sync trigger facility can be connected to the C-TX PC-sync-In port.

12. First Shots

- Half-shutter to focus, and the flash's LCD displays aperture and effective range etc.

622C Transmitter	C-TX Controller
<ul style="list-style-type: none"> • The 622C transmitter's Status indicator will flash yellow and its CH and GP indicators will flash green to indicate transmitting. 	<ul style="list-style-type: none"> • The C-TX Status indicator will light Green to indicate transmitting.

- The remote 622C Receiver will flash red and its CH and GP indicators will flash green. They will stay in a live state until the shutter is fully pressed or released. The same indications occur during a camera menu session.
- The AF-assist beam of the transmitter may assist focusing.
- Ensure that the subject is in the effective flash range, and fully press shutter button to shoot.



PART II – 622C TRANSCEIVERS

622C TRANSCEIVER CONTROL MODES **REMOTE & MIX**

The original YN-622C transceiver can work in either of two modes – Remote or Mix.

Remote Mode implements standard Canon wireless protocols.

Mix Mode can work with E-TTL and manual modes together, but loses the ability to manage manual levels from the camera.

Setting the Mode

- The Remote/Mix mode is set only on the transmitter 622C, not on any remote 622Cs.
- Do not try to set or un-set Mix mode using the buttons on remote receivers.
- To switch between Remote Mode and Mix Mode, hold down [CH SET] on the transmitter 622C until the channel indicator has winked red/green 3 times.
- In standby, the channel indicator will:
 - Stay off in Remote Mode
 - Stay lit in Mix Mode.
- The last-used setting is remembered by the Transmitter unit during power-down

Warning: If a different 622C is later used as the Transmitter, it may have remembered different settings!

Camera Remote Mode

- Type A camera External Flash menus take priority over *most* on-flash settings.
- Class 1 flashes are controlled by the camera's menus.
- Class 2 to 5 flashes are controlled by the *local* on-flash settings.
- Flash Mode is set in-camera and may be E-TTL or Manual or Multi.
- The CH indicator is off when in standby to indicate Remote mode.
- This is the Factory default mode.

On-Flash Mix Mode

- The local on-flash settings take priority. E-TTL and Manual can be mixed.
- All Classes of flash may be used. Each flash (including an on-TX flash) can be set locally on-flash to E-TTL, Manual or Multi depending on the flash's capabilities.
- Flash mode is fixed in-camera to E-TTL.
- FEC, FEB, Ratio and Shutter sync can be set in-camera.
- The camera's zoom setting is disabled. Each flash will use its own setting.
- If the shutter sync mode is set by the camera menu, the on-flash setting is ignored. A Type B camera defaults to hi-speed sync.
- The CH indicator stays lit when in standby to indicate Mix Mode.
- Any flash set to E-TTL will emit a preflash. If its mode is Manual or Multi, it won't.

E-TTL MODE Automatic Adjustable Metering

Type A cameras

Camera menus or buttons

- All (global), A:B (ratio), A:B C (ratio + FEC).
- FEC +/- 2 f/stops, with on-flash FEC settings adding to the result.
- E-TTL modes Evaluative or Average.
- E-TTL Flashes emit a pre-flash.

Type B cameras

Camera buttons

- All (global), no Canon ratio.
- FEC +/- 2 f/stops, with on-flash FEC adding to the result.
- E-TTL modes Evaluative or Average.
- E-TTL Flashes emit a pre-flash.

Ratios

Canon's lighting ratio becomes available through the Firing Group settings, when Wireless mode is enabled. This is the true professional multi-preflash "effective reflected light" ratio, not an approximation.

- Ensure that the light output requirements are within the capability of the flashes, possibly by increasing ISO, changing distance to subject, etc.
- Flashes with different maximum outputs can be mixed.

A:B Firing Group

- Set the lighting ratio from 8:1 to 1:8 (in 1/2 f/stop increments).
- A "normal" subject exposure will be calculated.
- This total exposure can be adjusted by the over-all FEC setting.
- The effective reflected light from group A flashes (including on-TX flash) and group B flashes will be evaluated by the camera and transmitted to the flashes by the 622C.
- Group C does not fire.

A:B C Firing Group

- Set A:B ratio as above.
- Set an FEC (-, 0 or +) for flashes in Group C.

Flash Exposure Compensation (FEC)

The over-all automatic flash exposure can be adjusted using the camera button or External Flash menu, combined with the on-flash setting. (This improves on Canon procedures.)

- Camera FEC can be set in 1/3 f/stop increments within ± 2 or ± 3 , depending on camera.
- Each flash has its on-flash FEC **added** to the camera-calculated output level. E.g. if the camera is set to -2, and the flash is set to +1, then total FEC for that flash will be -1.
- Set all on-flash FEC settings to zero, and use only camera FEC, to avoid unexpected results.
- Using a Receiver group of All (A+B+C), E-TTL can produce uneven lighting with multiple flashes due to differences in ambient light, flash power, distance, angle, etc. One flash can have a small FEC of, say, +1/3 FEC to balance more ambient hitting the other side of the subject.
- Using an A:B ratio, the ratio effect will be modified by the individual flash FEC. Under A:B C, C flash can be set to a value, and trimmed by the Group C FEC menu. Or, Camera -2 FEC plus C flash -2 FEC produces -4 FEC – greater than expected.

Flash Exposure Lock (FEL)

- The camera must be in a creative mode.
- Live View mode must be disabled.
- Flash mode must be E-TTL.
- First focus on subject.
- Then press the camera's [*] or [FEL] or [M-Fn] button, or as custom re-configured.
- Flash metering temporarily changes to Spot metering. The ambient and flash exposures are locked into the camera for 16 seconds, or while [half-shutter] remains pressed.
- "FEL" appears momentarily, and the <Flash> icon and "" are lit in the viewfinder. The values are discarded when the shot is taken, or a hi-speed burst ends.
- If the subject is too far away and underexposure may result, the <Flash> icon will blink in the viewfinder. Move closer to the subject and try the FE lock again.

Flash Exposure Bracketing (FEB)

- Set FEB in 1/3 f/stop increments up to -2 to +2 f/stops (-3 to +3 f/stops on 2012 and later cameras).
- The zero point for FEB is adjusted by the global FEC setting.
- The sequence of FEB is fixed at 0→ minus→ plus, even when the on-flash setting is different.
- The FEB function will be automatically cancelled after the three shots are taken.
- An E-TTL flash which does not support FEB can also be used.

MANUAL MODE User-determined Output Levels; No Metering

Remote Manual Levels

Type A camera menus can remotely control Mk II Speedlites and YN flashes.

- All (global), groups A and B, or A, B and C.
- Output levels 1/1 to 1/128, by Group
- E-TTL Flashes do not emit a pre-flash

All Flashes (Global setting)

- Set Flash Mode to Manual.
- Set Flash Output as required, 1/1 to 1/128 output level, in 1/3 f/stop increments.
- Either set Wireless function to Disable, or Enable Wireless with Firing Group A+B+C.

Two and three Receiver groups

- Set Flash Mode to Manual.
- Ignore Flash Output: it will repeat group A setting.
- Set Wireless function to Enable.
- Set Firing Group to A:B (C will not fire) or A:B C.
- Set each Group Output as required, 1/1 to 1/128 output level, in 1/3-f/stop increments.
- On-TX flash will fire at group A level, if Master Flash is enabled.

On-Flash Manual Levels

Type A, B or C cameras can trigger flashes where the output level has been set on-flash.

- Flash connected by PC-sync cable.
- Output levels set on individual flash.
- E-TTL Flashes will not emit a pre-flash

MULTI (STROBOSCOPIC) MODE

Usage is similar to Remote Manual and On-flash Manual. Stroboscopic mode is particularly effective with a highly-reflective subject against a dark background. Consider using a tripod, remote shutter release and external battery pack.

- Set Flash Mode to Multi.
- Set desired Flash output, Frequency per second (Hz) and Flash count, as provided by the camera.
- Frequency multiplied by Flash Count = minimum shutter duration.
- Limit rapid use and allow at least 15 minutes rest between frequent bursts.
- E-TTL Flashes do not emit a pre-flash

SHUTTER SYNC MODES

First Curtain (Front Curtain)

- The “normal” flash sync.
- E-TTL, Manual and Multi Flash modes.

Second Curtain (Rear Curtain)

The flash fires just before the shutter closes, instead of immediately after opening, to produce the appearance of forward motion with ambient light trails behind the moving object.

- The 622C provides 2nd Curtain sync (2CS) in either E-TTL or Manual Flash modes, including with off-camera flashes.
- Note that in E-TTL mode, a pre-flash is also emitted by each E-TTL flash.
- Not available in Multi (stroboscopic) flash mode.
- Not available in Wireless mode (and therefore no group functions available).
- Shutter of around 1/30th sec (see your camera guide) through to Bulb.
- Camera must be in a Creative mode.

Fast-Shutter Sync

High-Speed (HSS or FP)

- E-TTL and Manual Flash modes, syncs with all shutter speeds up to 1/8000s
- The camera must support HSS.
- If the hot-shoe flash does not support HSS, the max sync speed is 1/250s or less.

Super Sync (Flash Burn)

- Works with many hot-shoe and studio flashes, up to 1/8000s.
- Connection only through PC-sync port. A PC-sync cord required.
- Max. 300v trigger voltage.
- Set camera's shutter sync as Hi-speed sync.
- Use manual exposure or shutter-priority mode.
- For Type C cameras, the max PC sync speed is 1/250s or less.
- A flash on the hot shoe and another connected to the PC-sync port can be used at the same time.

Simple Trigger

- Single-contact cameras can trigger remote flashes (max sync speed is 1/250s).
- Single-contact flashes can be triggered by the 622C.
- Non-Canon flashes with multiple contacts can also be used, but may require either a single-contact adapter or a PC-sync cable, e.g. Nikon, Sony/Minolta.

CAMERA FEATURES

Ambient-only shot

- Turn transmitter off. 622C settings are remembered when powered up again.
- Or use type A camera menu Flash Firing – Disable.

High-speed Continuous Shooting

- Trigger keeps up with camera. (Tested at 6.5 fps.)
- An external flash battery pack is recommended for maintaining flash output consistency.

Live View

- Silent Mode must not be enabled, as Canon then prevents flash from firing.
- In Live Mode with Autofocus or Face Detection, the AF-assist beam will not be emitted.
- If AF-assist is not enabled, use the AF-ON camera button during Live View.

Modelling Light

- Works as designed. All flashes fire, including an on-TX flash.

FLASH FEATURES

Flash Zoom (Flash Coverage)

Canon provided a flash head zoom to provide lighting just wide enough to cover the lens's field of view. When the flash is off-camera, the lens zoom is irrelevant. Consider the zoom as a light modifier, for efficiency or artistic reasons. The 622C provides more flexibility than Canon's implementation. This may be affected by Canon's rules –

- Wide panel extended: 14mm
- Head in Bounce on Auto: --mm
- Head in Bounce on Manual: as set
- Auto-adjust for sensor size enabled.

Zoom Lock

An individual flash under remote control can have its zoom setting locked so that it is not controlled by the camera's zoom menu setting.

- Hold down [CH SET] on a 622C Receiver for several seconds until the channel indicator stays lit. (This is the same as setting mix control on a transmitter.)
- Adjust the flash zoom setting with the External Flash panel (automatic or manual).
- Hold down [CH SET] for several seconds to cancel. The channel indicator will go out.

Zoom and Remote Control

- Remote Control – camera zoom settings apply. Auto; Manual 24 to 105mm (or 200mm).
- With automatic setting, focal length of the flash may change with lens focal length.
- With manual setting, focal length of the flash supports manual setting (24-105mm).

Zoom and Mix Control

- The camera's zoom menu setting is disabled.
- Set each flash's zoom setting on-flash – Auto, Manual 24 to 105mm (or 200mm).

LCD Display

- Flash zoom, focal length, ISO, shutter speed, FE Lock, HSS change with settings.

Pilot Indicator

- A test flash can be fired on any individual flash by pressing that flash's Pilot Indicator.

622C TRANSCIVER FEATURES

Saving the Settings

- Most External Flash Menu settings (including AF-assist C.Fn) are saved automatically in the Transmitter 622C. Each 622C holds its own Master values, and can change the camera's menu settings unexpectedly when mounted on the camera.
- Not stored are FEB, Zoom, E-TTL Fire ratio and Group C's FEC, which revert to default values on power-up.

AF-Assist Beam

Autofocus Assist

When using Autofocus under low-light, the AF-assist beam can be emitted automatically to make it easier for the camera to auto-focus.

- Each 622C carries its own setting for the C.Fn 8 (or similar) enable/disable setting for "AF-assist beam firing".
- Set the value by placing a 622C on the camera's hotshoe, and use the camera's "External flash C.Fn settings" menu to make the setting.
- The user must also enable the AF-assist beam in the camera, Set camera's Custom Function / Autofocus assist beam to "Enable" or "Only ext. flash".
- This setting controls both the focus-assist and the confirmation indicator.
- The camera reads the setting from the 622C transmitter when a 622C is mounted.
- The 622C Transmitter will emit the beam when required by the camera.
- An on-TX flash which has an AF-assist beam function can also emit at the same time.
- Neither a remote 622C nor a remote flash will emit the A/F beam.
- The beam will not be emitted when Live mode or Face detection mode is used.
- The LED laser provides a bright pattern effective up to 4 metres. There is no health risk.

Menu Setting Confirmation

When a change in the camera menu is successfully applied to a remote Class 1 flash, the remote 622C's AF-Assist Beam will flash twice when the [Set] button is pressed

- The confirmation light will be emitted only if the remote 622C has C.Fn 8 enabled.

Sleep Wakeup

- Issued on half shutter or [Test].
- Flash must be mounted on a 622C hot-shoe, not by a PC-sync cord.
- Flash must have a wake-up capability.

Channel Indicators

The channel can be set by either the camera menu (Ch. 1-4 typically) or on the Transmitter.

CH LED	Radio Channel No						
	Ch 1	Ch 2	Ch 3	Ch 4	Ch 5	Ch 6	Ch 7
C1	On			On	On		On
C2		On		On		On	On
C3			On		On	On	On

Transceiver Status Indicator

Power-Up / Initialise

TX/RX	Status	Channel	Group	Duration	Notes
Both	Red	Green	Green	3-5 seconds	Also shows the current CH and GP. Then goes into Standby.

Standby / Remote-Mix

TX/RX	Status	Channel	Group	Duration	Notes
TX	Red			On	Remote mode
TX	Red	Green		On	Mix mode
RX	Red			On	Remote or Mix does not apply

Communicating

- Activated when half-shutter or full shutter is pressed, or when the camera Flash Menu is open

TX/RX	Status	Channel	Group	Duration	Notes
TX	Green	Green	*	Winking	Group shows Firing Group (below).
RX	Red	Green	*	Winking	Group shows Firing Group (below).

Low Battery Indicator

On startup or half-shutter, If the two batteries are at 2.2 volts or less, the 622C will indicate by winking several times then turn itself off.

- Batteries can be too low on startup to trigger this action.

TX/RX	Status	Channel	Group	Duration	Notes
Either	Red~Grn	(Green)	(Green)	Fast wink Dim, fast wink	

Group Indicators

There are two independent Group types:

Receiver Group

Test Firing Group

- Each current Group setting is remembered at power-down.
- An on-TX flash has no group indication. It is deemed to be in Group A, and uses Group A's settings.

Receiver Group

Each 622C can belong to only one selected Receiver Group: A (default), B or C.

- Set while in standby mode.
- The Receiver Group is displayed briefly at start-up, and when [GP] is pressed.
- While receiving, the Receiver Group LED will wink.

GP LED	Receiver Group			Notes
A	A			
B		B		
C			C	

Test Firing Group

When [TEST] is pressed, flashes are awakened; and when released a test flash is fired.

- Select Test Firing group by holding [TEST] and pressing [GP] repeatedly.
- The default test group is ABC.
- Testing includes connection through the PC-sync port.
- An on-TX flash will be included in the transmitter 622C's Receiver group, which may be Receiver Group A, B or C.

GP LED	Test Groups						
A	A			AB	AC		ABC
B		B		AB		BC	ABC
C			C		AC	BC	ABC

Camera Firing Group

When a 622C Transmitter is activated by pressing half-shutter or opening an External flash menu, the GP LEDs indicate the camera's Firing Group setting as shown in the Menu.

- The Firing group is set using the camera's External Flash/Wireless menu settings.
- Canon does not provide for just A or B or C.
- Groups A and B are always enabled.

GP LED	Firing Groups				Notes
(None)	Wireless Off				All, no Groups
A		A+B+C			All, Single Group
B			A:B		Two Groups
C				A:BC	Three Groups



PART III – C-TX CONTROLLER

C-TX CONTROL MODES

There are three control modes available.

Remote Control

This is the primary control method. Groups, flash modes, sync modes, FEC or M output can be set remotely.

Local Control

Settings for Flash Mode and its parameters are made on-flash, which then over-rides the remote settings.

Basic Trigger

The C-TX can be used as a sync-only radio trigger. The settings for a Manual output level are made on flash. The highest-speed shutter sync is 1/250s or lower, depending on the camera.

- The C-TX can be mounted on a single-contact hot-shoe camera
- The C-TX can be mounted on a multi-contact hotshoe camera, using a multi-pin to single-pin adapter.
- The C-TX can be connected to a camera's PC-sync-out port using an appropriate cable.
- The highest sync speed is 1/250S or less; HSS is not available.
- Configure Groups and Output levels in Manual mode to create desired lighting.

Fuji Cameras

- Some Fuji cameras will work in Remote Manual Control.
- Fuji X100, X100S and X-E1 have been reported to work in full remote Manual output and Zoom control, in 3 groups.
- High-speed sync up to 1/1000s has been reported.
- TTL and 2nd curtain sync is not available.
- The 622Cs are set to Remote mode.
- Compatible flashes, like the 580EXII must be used.
- The above cameras do not need Custom Function 04 Legacy Flash to be ON. The function is required when the C-TX thinks that it is on a full E-TTL camera.
- Care is required when mounting the C-TX on the camera to ensure that the pins ride up and seat fully.
- Press the Test button after changing C-TX settings to update the remotes, before pressing the shutter.

C-TX INTERFACE

The Buttons

The C-TX provides a set of buttons for changing its settings.

- The camera's External Flash menus can set some values, but these are limited to only those that are appropriate for the C-TX.
- Each of the buttons in the top row has a short-press function and a long-press function, and their labels show these two functions.



In this Guide's Part III, they will be referred to by their short-press label, or long-press label:

Short press	Long press	2-key press
[Gr]	[*]	
[Mode]	[E/M]	[Clear]
[Sync]	[Fn]	[Clear]
[Zoom]	[Ch]	
	[Test]	

The “navigation” buttons have no labels so will be referred to as follows:

Short Press	Functions
[Up]	More - plus 1/3 step
[Down]	Less - minus 1/3 step
[Left]	Less - minus Full step
[Right]	More - plus Full step
[Set/OK]	Setting complete.

Restore Factory Defaults [Clear]

- Press and hold [Clear] (i.e. Mode + Sync together) to reset values to Factory defaults.
- Main screen disappears and the page shows only a steady “CLR”.
- When completed, “CLR” will wink slowly.
- Release the [Clear] button.
- Main screen will re-appear, showing all the groups in TTL.

The LCD Display

Groups screen

- The default Groups screen is shown in the image.
- The last-used screen appears at power-on.
- Various operations terminate and return to Groups by Timeout, by pressing [Set/OK], by cycling through from a selection operation.
- Pressing any button will light the backlight briefly. Use [Set/OK] to avoid accidentally changing a setting.
- Most procedures assume starting from Groups.
- There are six lines.
 - Line 1: Current sync mode, and battery level,
 - Line 2: Operation labels and icons, and current channel.
 - Line 3: Zoom setting for each group.
 - Lines 4 - 6: Group flash mode and user adjustment.
 - Line 6 will also show on the right the AF-beam icon, if it is enabled.
- Lines 4 to 6 are interactive rows. The active row is selected with [Gr], and is indicated by the triangle on the left of that row.
- Other icons may appear in the top or right areas.



Indicators

Status Indicator (LED)

- In stand-by, the Status light is off.
- When communicating it is green.
- It turns red briefly when the shutter is released.

Battery charge Indicator

- The three bars (top right icon) will show when fully charged.
- As the stored voltage drops, the bars will disappear, starting from the right.
- When the icon winks, the battery is exhausted and must be replaced,

Access and Visibility

In a studio situation, and especially when the camera is on a tripod, a good-quality full Canon E-TTL cord can be used to move the C-TX off-camera to a more accessible position.

EXPOSURE MODES

Selecting a Group's Settings [Gr]

- [Gr] cycles through the three lines – Group s A, Group B and Group C.
- The arrow head on the left indicates which row is active.
- Changes in Groups will time out to end the operation.
- [Gr] also cycles through the three lines in some other screens.



Set Group Exposure Mode [Mode]

- Default is TTL. (“TTL” means either E-TTL or E-TTL II, depending on camera body. It does *not* mean Canon’s TTL for film cameras.)
- Select the required Group (has the left-hand arrow).
- Press [Mode] repeatedly to cycle through that group’s exposure modes - TTL (E-TTL), M (Manual), SS (Super Sync), and Off.
- The setting mode will quickly time-out.
- Ensure that the value for TTL or M is appropriate.



E-TTL Mode

Set Group FEC [Left] [Right] [Up] [Down]

- Ensure that the required Group is active and in TTL mode.
- Default is 0.0 FEC.
- Use [Left], [Right], [Up], [Down] to change FEC value between -3 f/stops to +3 f/stops in 0.3 or 1.0 steps.
- The setting mode will quickly time-out.

Set Global FEC [E/M]

An over-all FEC can be set either on-camera, or by pressing [E/M].

Use this feature for flash exposure bracketing (manual FEB), or to compensate for overall subject tonality or inconsistent camera under-exposure.

- Default is 0.0 Ev.
- Long-press [E/M]. The screen will show “TTL”, and a global FEC value.
- Use [Left], [Right], [Up], [Down] to change FEC value between -3 f/stops and +3 f/stops (Ev), in 0.3 and 1.0 steps..
- Leave the screen open to take a manual bracket of shots at different exposures.
- Return to Groups screen by pressing [Mode E/M] twice.
- The Group FEC value remains in effect, providing differential lighting within the global FEC.
- Any FEC set on the C-TX will over-ride FEC set on the camera. The camera’s Quick Control Panel will have an icon showing that the FEC is derived from an external device.
- The C-TX will not display the effect of camera-set FEC, when it is in effect.



Using Flash Exposure Lock FEL

- FEL is processed entirely in-camera.
- The C-TX works fully with FEL.
- Both Global FEC and Group FEC as set on the C-TX will be applied.

Enable Ratio and Back Lighting [E/M] or External Flash menus

Either the C-TX can set an E-TTL Ratio:

- Long- press [E/M] until TTL and Global FEC shows
- Long press [*] until the Ratio screen shows.
- **Line 2** shows ratio graphically e.g. |||| A:B ||. It provides a quick check on the setting, but is not precise. There can be up to 8 bars on one side (left or right) to 1 bar on the other side.
- **Line 4** shows ratio in steps and half-steps, e.g. 4:1. Range: 8:1 • 4:1 • 2:1 • 1:1 • 1:2 • 1:4 • 1:8
- **Line 5** shows Global FEC.
- Press [Gr] to move between lines 4 and 5. Press [Up], [Down], [Left], [Right] to change a value.
- Long press [*] until C (background) shows.
- **Line 6** shows Group C's FEC. Use [Gr], etc to select and change a value.
- Long press [E/M] twice to return to Groups screen and cancel the operation.

Or the camera can set an E-TTL Ratio:

- In the camera's External Flash / Wireless Firing Group Set A:B or A:B C as the firing group. Set an A;B ratio, and an FEC for C if required.
- The C-TX will open the Ratio screen with the camera's values.



Enable FEB [E/M] plus External Flash menus

Flash Exposure Bracketing is controlled from the camera's External Flash menus.

- FEB Auto Cancel: In External Flash Custom Fn / FEB Auto Cancel, set to Disable if multiple bracket sets are wanted.
- FEB Sequence: In External Flash Custom Fn / FEB Sequence, set to 0 - +, or - 0 +.
- FEB Range: In External Flash functions / FEB, set an FEB range.
- The C-TX will display the TTL screen, with a 3-image icon on the right.
- Press Shutter 3 times to complete the bracket.
- If External Flash C.Fn / FEB Auto Cancel is set to Enable:
 - FEB mode will be cancelled
 - the icon will disappear
 - the FEB range will be zero.
- Repeat the FEB range setting to take another set.
- Long press [E/M] twice to return to Groups screen.
- **Warning:** If External Flash C.Fn / FEB Auto Cancel is set to Disable, the function will remain in force. To cancel the mode, return to the External Flash menu and set FEB range to zero.

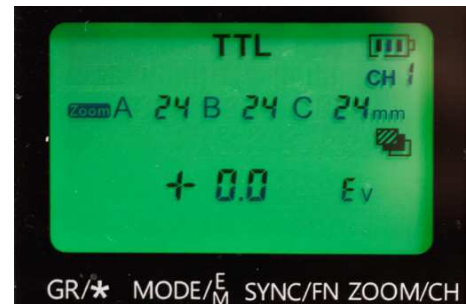

MANUAL Mode

Set Group Manual Output [Left] [Right] [Up] [Down]

- Ensure that the required Group is active and in M mode.
- Default is 1/16 output
- Then use [Left], [Right], [Up], [Down] to change Manual output from 1/1 to 1/128.
- Setting mode will time-out.

MULTI / Stroboscopic Mode

Enable Multi [E/M], [E/M]

Set up the camera for Multi as described in its owner manual. The flashes should have Manual levels and not be E-TTL-only.

- Long press [E/M] twice. The “Multi” screen will show:
Group A’s output level in row 1
Frequency per second (Hz) in row 2
Firing count in row 3.
- The default value is:
Group A Output 1/16
Frequency 1
Count “---“ (= “until shutter closes”).
- Press [Left], [Right], [Up] or [Down] to change the value.
- Press [Gr] to move to the 2nd row to change the global frequency per second.
- Press [Gr] to move to the 3rd row to change the global count.
- Use the camera’s Flash Control menus to set Manual outputs for groups B and C.
- While the Multi screen is open, the function is active.
- Long press [E/M] to cancel Multi and return to Groups.



SHUTTER SYNC MODES

Set Sync mode [Sync]

- Default is Hi-Speed (HSS).
- Press [Sync] repeatedly to cycle through
Hi-speed sync (HSS)
1st Curtain sync (1CS) - (no icon)
2nd Curtain sync (2CS)
- The setting mode will quickly time-out.

Super Sync requires HSS to be enabled. It is discussed in the C-TX Features section on p.43.



CAMERA FEATURES

Camera External Flash Menus

The camera's menus are controlled by the C-TX. An over-view of a pre-2012 camera menu:

Settings controlled by Menu only

- E-TTL II mode – Evaluative or Average can be set.
- FEB – a bracket range can be set.
- Multi – Groups B and C output levels.
- Flash Firing – locked on Enabled.
- Flash mode – locked on E-TTL.
- Custom Functions for FEB and AF-Assist Beam.

Settings controlled by C-TX only:

- Shutter sync – 2nd Curtain and Super Sync.
- If 2nd Curtain sync is enabled, set Group parameters through the C-TX.
- Zoom – Groups B and C.
- Super Sync timing.

Settings controlled by either C-TX or Menu

- Channel – Selectable within the range permitted.
- Shutter sync – 1st Curtain or Hi-speed can be set.
- FEC – a global FEC can be set. It will be ignored if a global FEC is also set on the C-TX.
- Firing Group – selectable when TTL and Multi screens are open. Default A+B+C.
- Multi can be selected when the [E/M] “TTL” screen is open, and the values can be set.
- Zoom – Group A only.

With cameras from 2012, the C-TX uses the RT menu and most functions can be set by camera menu, including Grouping settings but excluding 2CS and Super Sync.

Enable remote Shutter Release [Fn] 02 Shutter Release

- Use an LS-2.5 cable (supplied) to connect the on-camera C-TX to the camera's shutter release port. Cameras released from 2012 do not need a cable.
- Long press [Fn], then [Up] or [Down] for Fn 02 - Shu.
- Default value is Off. Turn On only when required.
- Press [Left] or [Right] to toggle between Off and On.
- Press [Set] to return to Groups.
- Press and release [Test] on a remote 622C:
 - The flash will fire a test flash.
 - If the camera is set to AF it will autofocus.
 - The shutter will open and fire the flash again.
- Single shot only - no Continuous, Bulb or Timer.



FLASH FEATURES

Set Group Zoom [Zoom]

- Default is 24mm
- Press [Zoom] repeatedly to cycle through the Zoom Groups to select the one to be changed. The selected group's value will blink.
- Press [Up] or [Right] repeatedly to select from 24mm to 105mm, then AU (automatic).
- Press [Down] or [Left] to step in reverse direction (AU, 105mm to 24mm).
- The setting mode will quickly time-out.

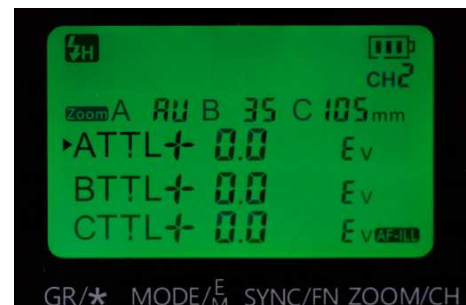

C-TX CONTROLLER FEATURES

Update C-TX Firmware

Version History

- 1.00** Pre-release version.
- 1.01** 01/07/14 First commercial release built in. Upgrade required only for pre-release testers.
- 1.02** 11/07/14 Added YN560-TX proxy mode. Improved stability.
- 1.03** 12/07/04 Made backlight/setting time longer. Changed Updater display to UP.
- 1.04** 18/08/14 Improved stability and transmission range.
- 1.05** Fixed 7D HSS problem, and fixed 7D II E-TTL compatibility.
- 1.06** 03/12/14 Improved power supply on some circuit boards. Corrected display errors.

1. Download and instal the Firmware Updater

- Do this once, unless the Updater itself is updated. It may be worth re-installing with the current Updater to be sure.
- Updating requires a Windows computer (not an emulator).
- Go to product page <http://www.hkyongnuo.com/e-detailly.php?ID=348>
- Download **YN_Trigger_Updater.zip**
(It may be necessary to first turn off your malware filter.)
- Unzip YN_Trigger_Updater_Setup.exe.
- Run **YN_Trigger_Updater_Setup.exe** to install the driver and updater in your computer C:\Program Files.

If there is a problem getting the driver installed in Win 8.1, download

https://dl.dropboxusercontent.com/u/63687922/YN_Trigger_Updater_Setup.zip

Unzip and run.

Or, go to your Program Files / Yongnuo Trigger Updater / Driver / dpinst_x64.exe (or_x86.exe for 32-bit systems), and run it.

2. Download and Unzip - YN_622C-TX_FW_V 1.04.zip (or later)

The YN web page may not yet show the latest version. If not, use:

https://dl.dropboxusercontent.com/u/63687922/YN622C-TX_FW_V1.04.zip

- The expanded files include
YN622C-TX_FW_V1.04.dfu.
Changelog_CN.txt and Changelog_EN.txt – shows changes in the update.

3. Set C-TX to Upgrade Mode, and connect

- Turn off C-TX, then hold down [Mode] and turn the C-TX on again. The firmware upgrade mode will show **YN | 622 | 1.01 U P**, where 1.01 is the current version in the C-TX.
- Connect the C-TX to your Windows PC via a USB miniB cable (e.g. Canon camera cable).

4. Instal the Firmware in the C-TX

- Run **YN_Trigger_Updater English** from your computer's Start menu. (CN or a language-selectable version may be available.)
- Use "Browse..." to navigate to the required ".dfu" version, and open.
- Check that firmware version is as expected, then click "Update".
- The Updater will show e.g. "YN-622C Controller, Version 1.02 updated successfully", and the C-TX will reset automatically using the new version.

If an error is encountered, turn off the C-TX and try again. If installation fails a second time, re-download the files.

Set Channel [Ch]

There are 7 radio channels which can be used to avoid interference from other photographers, or from sources like wireless network hubs.

- Default value is 1.
- Long press [Ch] to activate channel selection. The current value will wink.
- Quickly press [Up] or [Right] to step cyclically up through 1 to 7. Use [Down] or [Left] to step down.
- The setting mode will quickly time-out.
- Ensure that the remote 622Cs are re-assigned the same channel.

Test Communication and Flash Readiness [Test]

- Press and hold [Test] to awaken the flashes. The Status Indicator will light green.
- The 622Cs and their flashes will awaken, and their indicators show ready. Ensure flash pilot lights are showing fully charged.
- Release [Test] to fire a test firing. The Status Indicator will turn red.

Set Super Sync timing [Fn] 01 Super Sync Timing

- Default value is 0.0.
- The setting is global and applies to all groups in SS.
- Long press [Fn] then [Up] or [Down] to select Fn 01 - SS.
- Press [Left] or [Right] to step between 0.0 and 2.0 in 0.1 timing increments.
- Press [Set] to return to Groups.



Using Super Sync (Flash Burn)

Super Sync is designed to allow studio flashes to be used at fast shutter speeds up to 1/8000s.

- Connect the studio flash to a remote 622C using a PC-sync cord.
- Set C-TX shutter sync to Hi-speed sync (HSS).
- Flash output of 1/1 may be needed for this technique.
- Take a test shot and check image for a shutter shadow. Adjust the timing between 0.0 and 2.0 until the optimum lighting is achieved.
- There may be a gradient in the image which will need correcting in post-processing.

Enable AF-Assist Beam [Fn] 03 AF Beam

The red AF Beam on the C-TX can be either On or Off.

- Default value is On.
- Long-press [Fn] to show function screen.
- Press [Up] or [Down] repeatedly to show Fn 03 - AF.
- Press [Right] or [Left] to toggle between On and Off.
- Press [Set/OK] to apply and return to Groups.

When the Beam is enabled, it will still fire only when the camera calls for it.



Enable use on non-Canon cameras [Fn] 04 Legacy Flash Trigger

Only Canon cameras talk the Canon code that the C-TX works with. Some other brands, like Fuji, falsely make the C-TX think it is on a Canon camera. Function 04 prevents the false detection, and the C-TX then works as a simple trigger.

- Default value is Off. Turn On only when required.
- Only Manual operation is available, not E-TTL.
- Long press [Fn], then [Up] or [Down] for Fn 04 - Leg.
- Use [Left] or [Right] to toggle between Off and On.
- Press [Set/OK] to set and return to Groups.
- On 2007+ flashes, Manual outputs are remotely controllable in Groups. Other flashes need their outputs to be set on-flash,
- Warning: Leaving Fn 04 set to On disables all control when the C-TX is on a Canon.



Enable remote Manual control on pre-2007 flashes [Fn] 05 EX Compatibility

Function 05 provides remote control in Manual mode for early E-TTL-capable Speedlites, e.g. 380EX, 430EX, 550EX and 580EX.

On remote 622C

- Set to the desired group.
- Set the flash itself to E-TTL.
- The flash's screen will not display the flash output.

On C-TX

- Long-press [Fn] then [UP] repeatedly until Fn 05 - ECO is displayed.
- Default is Off. Turn On only when required.
- Press [Left] or [Right] to toggle Off to On.
- Press [Set/OK].
- In Groups screen, set the flash's group to M mode.
- Set a test output level for the group.
- Take a shot.
- Adjust the group's output level using [Left], [Right], [Up] or [Down].



Mixed flashes

- Early and late models flashes (e.g. 550EX and 580EX II) can be included in the same group, or in different groups.

Enable Free Mask cutout image [*]

Free Mask provides a silhouette cutout image of a dark subject and a fully-lit background for post-processing.

- Default is "not enabled".
- Take a fully-lit image of the subject.
- Long-press [*]. The screen will show a special case of Groups, with both A and B groups set to Off, leaving C still enabled.
- Take one or more mask images of the subject.
- Return to previous settings in use by long-pressing [*].

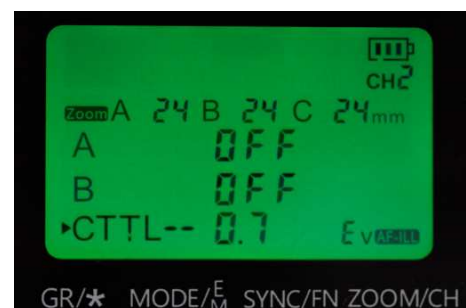

Enable Proxy Mode [Fn] 06 Proxy

Proxy mode allows the C-TX to be slaved to a YN560-TX Manual-only Controller. The C-TX then forwards the commands to flashes on remote 622Cs.

- The YN560-TX is mounted on the camera, and controls remote YN560 III Manual-only flashes
- A stand-alone C-TX can receive those commands and forward them to remote 622Cs.
- Proxy mode is available in a C-TX with firmware v.1.02 or later.
- The channel on the YN560-TX, YN622C-TX and YN622C remotes must be the same.
- The flashes on the 622Cs must be in Manual mode.
- Long press SYNC/FN key to enter the custom function and go to FN.06 (Up/Down key).
- Change the value to ON (Left/Right).
- Place the YN622C-TX anywhere within the transmission range of YN560-TX.
- Use YN560-TX to control Manual output/zoom of the ettl flashes on YN-622C remotes.



USEFUL STUFF

CANON EXTERNAL FLASH MENUS

The camera's External Flash menus are the main interface for using the 622Cs. The menus change interactively as selections are made. The 622C controls or disables some menu items.

- The 2007 style menus are described first.
- The 2012 style menus with the new Quick Flash Control panel (6D, 5D III, 650D/T4i and other new models) are then described.
- Select the optical pulse transmission menu on RT-capable cameras.

Confirmation of Setting

When a change to the camera menu is successfully applied to a remote flash, the AF-Assist Beam of its 622C receiver will flash twice when the [Set] button is pressed, to indicate that the change was successful.

- Press [SET] after making a menu value change. Don't have to redo the setting!
- The confirmation light will be emitted only if the remote 622C has C.Fn 8 enabled.

Starting menu item

- Flash Control (or External Speedlite Control)

First menu

- Flash Firing Enable or disable the 622C transmitter.
- External flash func. setting 622C is identified as an external flash.
- External flash C.Fn setting FEB auto cancel – locked Enabled.
FEB sequence – locked.
AF-assist beam firing – Enabled or Disabled.
- Clear ext. flash C.Fn set.

External flash function menu

- Flash mode E-TTL II, Manual, MULTI. (TTL, Auto external, Manual external disabled.)
- Shutter sync 1st Curtain, 2nd Curtain (if Wireless Disabled), Hi-speed
- FEB Max. -3 to 0 to +3 f/stops where the centre point (0) is set by the FEC setting.
- FEC Flash FEC -2 to +2 (later cameras -3 to +3). Interacts with on-flash settings.
- E-TTL II Evaluative, Average
- Zoom Auto, 24 28 35 50 70 80 105mm (later cameras 200mm)
- Wireless Enable, Disable
- [INFO] Clear Speedlite settings.



Wireless Settings

- Wireless Function Enable, Disable.
- Master flash Enable, Disable. On-TX flash will emit preflash and focus-assist, but not exposure flash.
- Channel 1 to 4.

Firing Group, in E-TTL II flash mode

- A+B+C All E-TTL capable flashes will pre-fire for a combined exposure evaluation.
- A:B Set lighting ratio from 8:1 to 1:8, using E-TTL, C is not settable and not fired.
- A:B C Lighting ratio 8:1 to 1:8, plus C with exposure comp. -3 to +3 f/stops.



Firing Group, in Manual flash mode

- A+B+C All remotely-controllable flashes use Group A, 1/1 to 1/128 in 1/3 f/stops.
- A:B Group A output 1/1 to 1/128
Group B output 1/1 to 1/128
Group C not set or fired
- A:B C Group A output 1/1 to 1/128
Group B output 1/1 to 1/128
Group C output 1/1 to 1/128
- Setting for group A will also mirror Flash Output in previous menu page.



Flash mode Multi

- Flash Output 1/4 to 1/128. 1/1 and 1/2 are not available.
- Frequency 1 to 100 Hz.
- Flash Count - - Firing until shutter closes, or battery or lamp fails.
1 to 100 Max determined by Output and Frequency.

New Quick Flash Control Panel

Starting Menu - 6D, 5D III, 650D/T4i

Select Camera 2 menu, External Speedlite control item.

- Flash Firing Enable or disable the 622C transmitter.
- E-TTL II metering Evaluative or Average.
- Flash sync speed in AV mode
- Flash Function settings Opens Quick Flash Control panel, as below.
- Flash C.Fn setting.
- Clear settings.

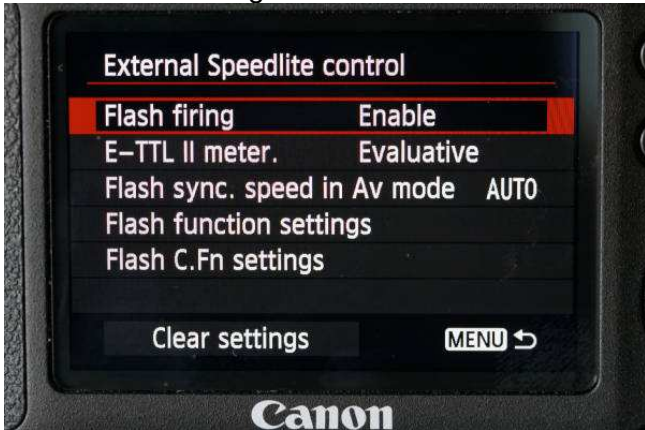

Quick Flash Control panel

Displays current settings, and permits changes. The display changes inter-actively.

- Add “External Speedlite Control” to “* My Menu”, and move to top.
- Enable “Display from My Menu” to start with this menu when [MENU] is pressed.

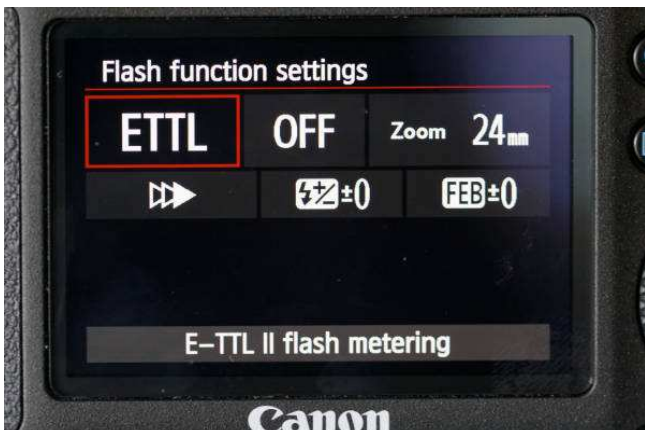
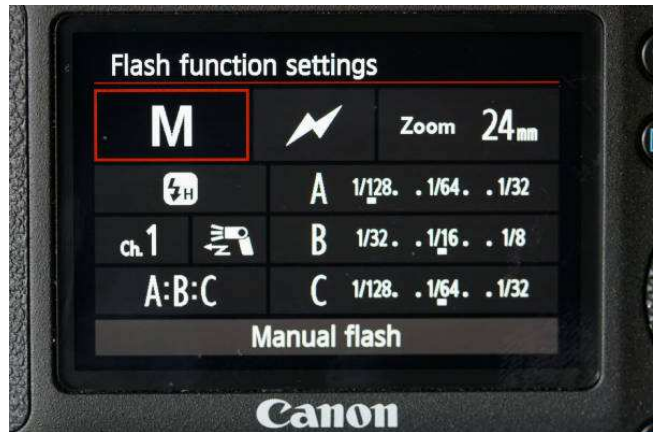
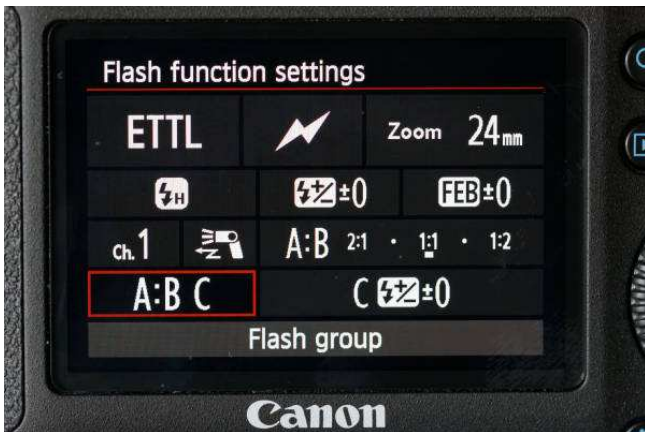

LIGHTING SCENARIOS

E-TTL Ratio – Main and On-camera Fill

Automatic flash exposure, remotely controlled, with type A camera and class 1, 2 and 3 Flashes

On shutter release, the camera will call for pre-flashes, evaluate power levels required, and produce a normal exposure from the group B flashes, with reduced fill from the on-camera flash.

622C Transmitter	C-TX Controller
<ul style="list-style-type: none"> Type A Camera + 622C + 580EXII 	<ul style="list-style-type: none"> Type A Camera + C-TX + flash bracket + 622C + 580EXII.
<ul style="list-style-type: none"> On transmitter: Re-set [Ch + Gp] to Remote mode. 	<ul style="list-style-type: none"> On C-TX: Re-set [Clear]
<ul style="list-style-type: none"> On-TX flash is automatically in firing group A. 	<ul style="list-style-type: none"> On-bracket 622C: Set to firing group A.
<ul style="list-style-type: none"> On camera: Set Flash Mode to E-TTL, and FEC to 0. 	<ul style="list-style-type: none"> On C-TX: Set groups A and B: to E-TTL, and FEC to 0. Set group C to Off.
	<ul style="list-style-type: none"> On C-TX: Long press [E/M] for TTL screen
<ul style="list-style-type: none"> On camera: Firing Group: A:B. 	
<ul style="list-style-type: none"> On camera: Fire Ratio: 1:3. 	
<ul style="list-style-type: none"> On camera: Zoom:24mm to cover umbrella surface. 	
<ul style="list-style-type: none"> Set up light-stand + umbrella + 2-flash bracket + two (622C + 430EXII) 	
<ul style="list-style-type: none"> On remote 622Cs: Set to firing group B. (Remote flash outputs: will be set remotely.) 	
<ul style="list-style-type: none"> Adjust FEC and Ratio camera's menus or buttons/dials, or from the C-TX's LCD. 	

Manual Levels – Main, Fill (On-camera) and Background

User-set flash exposure, remotely controlled, with type A camera and class 1, 2 and 3 flashes

622C Transmitter	C-TX Controller
<ul style="list-style-type: none"> Camera + 622C + 580EXII 	<ul style="list-style-type: none"> Camera + C-TX + flash bracket + 622C + 580EXII.
<ul style="list-style-type: none"> On transmitter: Re-set [Ch + Gp] to Remote mode 	<ul style="list-style-type: none"> Re-set [Clear]
<ul style="list-style-type: none"> On-TX flash is automatically in firing group A. 	<ul style="list-style-type: none"> On-bracket 622C: Set to firing group A.
<ul style="list-style-type: none"> On camera: Flash Mode to Manual. On camera: Firing Group: A:B C. Set group A output to 1/32 Set group B output to 1/8 Set group C output to 1/4 	<ul style="list-style-type: none"> Set group A to Manual, 1/32 Set group B to Manual, 1/8 Set group C to Manual, 1/4
<ul style="list-style-type: none"> Position a light stand + 622C + 430EXII as Main. Remote 622C: Set to firing group B. Its flash output: will be set automatically. 	
<ul style="list-style-type: none"> Position a light stand + 622C + 430EXII as Background. Remote 622C: Set to firing group C. Its flash output: will be set automatically. 	
<ul style="list-style-type: none"> Adjust each group output using the camera's menus, or on the C-TX's LCD. 	

Augmented Ambient – House Lighting + Flashes, and on-camera Main

Mixed E-TTL automatic Main flash exposure, with flashes in Manual lifting ambient light.

Indoor event photographers sometimes use flashes high on light-stands to bounce light off the ceiling to improve background detail, or to provide hair- or rim-light. An on-camera flash provides the main light for the subject.

622C Transmitter	C-TX Controller
<ul style="list-style-type: none"> Type A Camera + 622C + YN568EX. 	<ul style="list-style-type: none"> Type A Camera + C-TX + flash bracket + 622C + YN568EX
<ul style="list-style-type: none"> On transmitter: Change to Mix mode – press [CH] for 3 seconds. CH indicator shows steady green. 	
<ul style="list-style-type: none"> On-TX flash: Set the mode to E-TTL. 	<ul style="list-style-type: none"> On C-TX: Set group A to TTL Set groups B and C to Manual at 1/4
<ul style="list-style-type: none"> On camera: Flash Mode is E-TTL. On camera: Set firing group: to A:B C. 	
<ul style="list-style-type: none"> Two (622C + 580EXII + battery pack on light stand) for bounce or rim light. 	<ul style="list-style-type: none"> Two (622C + 580EXII + battery pack on light stand) angled bounce or rim light.
<ul style="list-style-type: none"> On remote 622Cs: Set firing groups to B and C. 	<ul style="list-style-type: none"> On remote 622Cs: Set firing groups to B and C.
<ul style="list-style-type: none"> On remote flashes: Set to Manual mode at 1/4 output. 	<ul style="list-style-type: none"> Flash output is set remotely.

Remotely adjusting augmenting flashes

622C Transmitter	C-TX Controller
<ul style="list-style-type: none"> On transmitter: Set back to Remote mode – press [CH] for 3 seconds. CH indicator turns off. 	
<ul style="list-style-type: none"> On camera: Set flash mode to Manual and adjust outputs for B and/or C. The on-TX flash will also change to Manual. 	<ul style="list-style-type: none"> On C-TX: Select Group B or C to be changed. Adjust output level.
<ul style="list-style-type: none"> On transmitter: Return to Mix mode - press [CH] for 3 seconds. CH indicator shows steady green. 	
<ul style="list-style-type: none"> On-TX flash: Re-set to E-TTL mode. 	

Remotely turn off augmenting flashes (APOAZ technique)

622C Transmitter	C-TX Controller
<ul style="list-style-type: none"> On remote 622Cs: Set to say Channel 2. 	<ul style="list-style-type: none"> Multiple channels not required.
<ul style="list-style-type: none"> Set transmitter to CH 2 to use remote lights, and on-TX flash will still fire. 	
<ul style="list-style-type: none"> Set transmitter to CH 1 to use only on-TX flash. 	<ul style="list-style-type: none"> On C-TX: Select Group B or C to be changed. Change Flash Mode to Off.

Augmented Ambient continued...

Using class 4 augmenting flashes

Instead of using Class 1 flashes on stands, use Class 4 flashes like the YN-560. The maximum sync speed may be 1/250s

622C Transmitter	C-TX Controller
<ul style="list-style-type: none"> On camera: Set Flash mode to E-TTL. 	
<ul style="list-style-type: none"> On transmitter: Set to Remote mode. 	<ul style="list-style-type: none"> On C-TX: Set group A's Flash Mode to TTL.
<ul style="list-style-type: none"> On-TX flash: Mount a class 1, 2 or 3 Flash for Main in E-TTL. 	
<ul style="list-style-type: none"> On stands: Mount class 4 Flashes and set on-flash to a Manual output level. 	

Manual control of Four Independent Augmenting Zones (Victor S, VA, technique)

This scenario provides for four corner flashes on stands, each remotely controllable, with an on-camera flash as Main/Fill.

- It requires a Type A camera, Class 1 flashes, a 622C transmitter and a C-TX controller, plus a sync cable.

Function	Item	Settings	Comments
Main	Type A camera	Flash Mode Manual Wireless = Enabled Master Flash = Enabled Ch = 2 Firing Group = A:B Gp A = M 1/x Gp B = M 1/x	The on-top flash is not in a "channel" and adopts the camera's Gp A settings as set in the menu.
	622C and Flash	Ch 2, Gp B	Gp B sets the Zone 4 output.
Extended Control	C-TX	Ch = 1 Gp A = M 1/x Gp B = M 1/x Gp C = M 1/x	
	PC-sync cable	622C transmitter sync-out port to C-TX sync-in port	Tape C-TX to camera or a flash bracket. Give as much clearance from camera and flash as possible.
Zone 1	622C and Flash	Ch 1 Gp A	Level or Off from C-TX
Zone 2	622C and Flash	Ch 1 Gp B	Level or Off from C-TX
Zone 3	622C and Flash	Ch 1 Gp C	Level or Off from C-TX
Zone 4	622C and Flash	Ch 2 Gp B	Level from camera menu Gp B Change Channel to 3 for Off

- The range of the C-TX may be too short for control in a larger space.
- PC-sync cables are notoriously unreliable – buy a high-quality one!
- Take care using faster shutter speeds. The 622C issues the Fire! signal when the shutter has opened, and the C-TX must wake up and send instructions to the remote 622C. This then awakens and instructs the flash to fire, possibly too late due to the propagation delay.

Augmented Ambient continued...

Two-Shooter setup

A second shooter can share the augmenting flashes. But, there is a problem – preventing the zooming and firing of the other camera’s on-TX flash.

622C Transmitter	With C-TX Controller
<p>Both Cameras</p> <ul style="list-style-type: none"> • 622C as transmitter set to REMOTE mode and receiving group C. • Camera set to E-TTL mode, firing group A:B and a ratio/output. • On-top Flash set by camera to E-TTL. 	<p>Both Cameras</p> <ul style="list-style-type: none"> • 622C as transmitter set to MIX mode and receiving group C. • Camera set to firing group A:B. Mix mode forces the camera to E-TTL. • On-top Flash set on-flash to E-TTL.
<p>Augmenting Flashes</p> <ul style="list-style-type: none"> • Remote 622Cs set to receiving group B. • Flashes will be set remotely to E-TTL or a Manual output. 	<p>Augmenting Flashes</p> <ul style="list-style-type: none"> • Remote 622Cs set to receiving group A and/or B. • Flashes will be set remotely to a Manual output..
	<p>C-TX Controller, hand-held.</p> <ul style="list-style-type: none"> • Set group A to a Manual output, group B to Manual output and group C to E-TTL.
<p>When either camera takes a shot, its own on-TX flash is treated as group A and fires. The augmenting flashes are treated as group B. The other camera’s flash is treated as group C. As group C is not enabled in firing group A:B, it does not fire.</p>	<p>This configuration provides for two shooters, and one or two remotely-controlled groups for augmenting flashes.</p>

Class 5 Studio flashes with Cybersync Commander (DM Ward technique)

Mixed Speedlites and remote-controlled studio flashes

The Cybersync provides easy remote control of studio flashes for adjusting power, and the 622C provides triggering of the studio flashes and full control of any 622C-mounted hot-shoe flashes.

622C Transmitter	C-TX Controller
<ul style="list-style-type: none"> • Camera + 622C + YN568EX. 	<ul style="list-style-type: none"> • Camera + C-TX + flash bracket + 622C + YN568EX
<ul style="list-style-type: none"> • Place a 622C nearby (neck cord or pocket) and mount a Cybersync Commander on it. 	
<ul style="list-style-type: none"> • Mount studio flashes, e.g. Einsteins, on stands for augmented ambient or rim light. Connect a Cybersync receiver to each. 	

SUGGESTIONS

Batteries

The 622C is designed primarily as a 3v (2x 1.5v) unit, but can be used with lower-output batteries e.g. 2.4v (2x 1.2v). However, they require more constant attention by the user to battery condition.

- Alkaline batteries start at 1.5 volts and slowly drop voltage during use.
- Well-maintained NiMH rechargeables in good condition start at around 1.2 volts, (under load) and hold their voltage until almost exhausted.
- Alkalines lose little voltage when not in use, but NiMH rapidly lose substantial voltage.
- The 622Cs are programmed to cut out at about 2.2 volts for the pair. A good pair of Alkalines give a starting overhead of 0.8 volts, while even the best NiMH pair have an overhead of only 0.2 volts above cut-out.
- Alkaline characteristics are well suited for use in the 622C, and testing the triggers with a quality new set can help rule out batteries as a source of a problem.
- NiMH Rechargeables are great as flash batteries, being capable of a rapid discharge into the flash's capacitor.

Battery Orientation

Flashes are often used in low light. It can be hard to read the embossed polarity markers at the bottom of the battery case. Use a silver marker pen to highlight the two [-] markers.

Camera's Custom/My Menu

Set up the Flash Control/Function menu as the first My Menu item. Then set the My Menu to appear first when Menu is called.

Hybrid Mode - Master and Slave with 622Cs

Use two 622Cs to bridge the distance from camera, and Canon Wireless to fire 2 or more flashes.

- Only Manual mode can be used. Set camera to Manual flash mode, 1CS or HSS.
- Place a 622C on-camera.
- Use a non-controllable Master flash (e.g. 580EX) directly on the other 622C, or a controllable Master flash (e.g. 580EXII) connected by i) an adapter which has only two wires between hot-foot and hot-shoe, or ii) a PC-sync cord to an adapter foot.
- Set the Master flash on-flash as Master, Manual mode and power level, 1CS or HSS. Groups are probably not available (untested).
- Set the other flash (e.g. 430EX) to Slave and E-TTL. Ensure the slave's wireless sensor can see the master's flash head.

Test fire. The 622Cs should communicate, and the remote 622C will fire the Master. In turn, the slave should change to a manual power level and fire. Try with a different Manual level on the Master.

Light Meter Technique using 622Cs

- Set Manual levels, either by External Flash menus or by on-flash settings.
- The test fire will be at the level as it is displayed on the LCD of the flash.
- The test button will not change the setting of the flash.
- If Remote control is being used, first press half-shutter to ensure that settings are applied
- E-TTL will produce a pre-flash, which may confuse the light meter.
- Trigger with any 622C on the same channel. It may be a hand-held one.
- With the C-TX controller, connect a suitable Light Meter to the PC-sync IN port.

Mixing with Other Triggers

Other non-ETTL triggers such as the RF602, RF603 or Cybersync triggers can be mounted on the 622C transmitter or a remote 622C to fire the other trigger's remote receivers.

Numbering the Units

Record the serial number and date of purchase. It is found on the printed label inside the battery case (622C) or stamped into the bar between the batteries. I use the end digits on a label attached to the end to identify the unit – it helps to keep track of problems

Wireless Mode Setting

For the 622C transmitter, keep this setting at Enabled, and disable it only when 2nd Curtain sync is required. (5D II and III, and possibly others, change the sync timing if Wireless is Disabled.) The C-TX controls the setting automatically.

Umbrella / Light Stand Mount

I recommend a lie-flat bracket for safety, stability and on-axis light beam, especially for a softbox or umbrella. To secure the flash, use a Frio Cold Shoe, an American product. (See the blue mounting clip in the images below.)



A home-made mount for one or two flashes using a cheap ball swivel, some aluminium bar and a Frio cold shoe. For better security, add a Velcro strap around the head.



A two-flash adaptation of the single bracket. It has two cross-bars added and uses a standard umbrella swivel.

An example of a commercial mount is the Godox swivel bracket with Bowens S mount, using a flash-head clamp.



© 2014 Philip Weston

TROUBLE SHOOTING

Aperture, distance are not displayed on the flash when half pressing the shutter

- With the flash on the transmitter, use the menus to set the flash mode or shutter sync.

Cold temperature results in failure

- Batteries can have their output reduced to below operating voltage in cold conditions. This is less likely to arise with Alkaline cells.

Erratic Behaviour

- Un-mount all equipment, then re-mount ensuring each hot-foot is pressed fully in.
- Replace the batteries in the 622Cs, preferably with Alkaline ones. Make no assumptions.
- Reset the 622Cs to factory default settings. (Hold [CH SET] and [GP Set] until the Status indicator flashes red/green three times, then release.)
- Reset your Speedlite. Instal the Speedlite directly on a type A camera, and reset the flash using the menus *"Flash Control / Ext Flash Function settings / Clear Speedlites Settings"* and *"Flash Control / Clear External Flash C.Fn settings"*, which re-set most main and C.Fn settings.
- Reset the camera to its factory default settings.

External flash function menu not available

- The transmitter is not installed correctly. Ensure that it is re-seated fully.
- The contacts of the hot shoe are dirty. Clean both sets of contacts, including under the rails
- One or both batteries are exhausted. Replace BOTH.

E-TTL underexposure or overexposure:

- Suggest enabling wireless flash function when using E-TTL flash mode, and adjust the position of the flash, use FEC/FEL function, check flash's effective range.
- It may overexpose when E-TTL and manual flash are used at the same time; the manual flash suits being used as a backlight.

E-TTL Automatic Adjustments – AFR and NEVEC

Canon has two technologies which can produce exposures which are not expected. AFR is Automatic Flash Reduction, and NEVEC (Negative Evaluative Exposure Compensation) provides automatic ambient reduction.

- The EOS 1D professional bodies do not have these features.
- With AFR, camera modes TV, AV and M default to fill flash mode and AFR is applied: under 10 EV: AFR is not applied, and exposure is for a flash-lit scene; 10 EV to 13 EV: AFR is applied increasingly; Over 13 EV: AFR of 1.5 to 2.0 f/stops gives a fill-flash exposure.
- NEVEC is applied in AV or TV mode but not M. It reduces background exposure so the foreground flash makes it "pop". Ambient may need to be reduced to allow room for flash. E-TTL determines the Flash output required on top of the reduced ambient.
- This chart shows the effect of the two together. It can be quite substantial!

EV	AFR (FEC)	NEVEC (EC) ISO400	Effective ambient:flash ratio
7	0	-1	1:2
8	0	-1	1:2
9	0	-1	1:2
10	-0.5	-0.5	1:1
11	-1	0	2:1
12	-1.5	0	3:1
13	-2	0	4:1

Fails to power on or automatically shuts down

- The batteries are installed incorrectly or are exhausted. The device will power down automatically before the battery is fully depleted to avoid being over-discharged.
- Install fully charged batteries according to the battery compartment indicators.
- Battery low – on startup or half-shutter; Status will rapidly wink Red/Green, and the CH and GP indicators will dimly wink also. If the voltage becomes low (total 2.2 volts), the 622C will turn off automatically. Batteries can be too low on startup to trigger this action.

Firing groups cannot be disabled

- With Canon cameras, you can only disable group C by selecting Firing Group = A:B.
- Groups A and B are always fired no matter whether you select "ALL", "A:B", "A:B:C" or disable the Wireless function.

Flash does not fire

- Ensure the batteries of all devices are fully charged, and flash has fully recycled.
- Check the connection between the 622C and camera, and 622C and flash.
- Ensure that the indicators show matching channels and Receiver groups.
- Check that flash is not disabled by its overheating protection, is not in continuous zoom adjustment, or in sleep status.
- Use the Pilot button to test the flash.

Flash emits an unwanted pre-flash

- If the flash's mode is E-TTL, it will emit a preflash. If the flash's mode is Manual or Multi, it won't.

Flash zoom cannot be set via camera menu

- When the Mixed Control mode has been set in the transmitter, or zoom locking has been set in the receiver, zoom can't be set via camera menu.
- The Zoom setting of the on-TX flash needs to be set separately.

Full-power flash

- This can happen if the shutter release is fully pressed before the system has aligned every component. The Fire! command can over-ride any setting up in progress.
- On startup or on any major adjustment to remote flashes, press half-shutter and release to force system updating.

Gap between E-TTL Pre-flash and Main Flash

- This can be due to using only Group A flashes, but with all three firing groups (A:B C) set. The camera takes time to issue instructions to non-existent Group B and Group C flashes.

Half Shutter

The shutter half-press is **critical** for the 622C to awaken remotes and their flashes, and update remotes with current settings. When the camera shutter says Fire! this command over-rides everything else, and misfires are likely.

Intermittent Access to Camera Menus on 6D

Magic Lantern for the 6D has an issue with Speedlites. Disable Magic Lantern.

On-TX flash doesn't fire

- Enable the Master Flash firing in the wireless menu setting.

Unable to set channel 5, 6, 7 via camera menu

- The camera can only set channels 1 to 4. Set other channels using [CH SET].

SERVICING

If a malfunction of a 622C is suspected, first check through this guide, and photographic forums. If the problem remains, contact your supplier – they are responsible to YongNuo for providing support. Or, email service@hkyongnuo.com.

AF-Assist Beam

The AF-Assist Beam sometimes needs re-alignment, and some have fixed the LED and cradle. The vertical angle depends on how close to the subject the camera and 622C will be.

Hot-Foot

The hot-foot can work loose. This repair is simple, but has a high risk of losing parts during the process.

Solder joints

There is little on the circuit board that is serviceable by even the skilled user, but connections between it and external items like battery contacts or the pc-sync port can need re-soldering.

Opening C-TX case – don't.

If you want to open the C-TX case, first decide that you will throw away the remains after your play.

Opening the 622C case

Opening the case voids your warranty. It may be worth risking the unit, depending on urgency, skill, tools, etc. The next page show what is involved. It's your risk.

The case can be opened by removing five #0 Philips head self-tapping screws. (One is under the warranty sticker inside the battery compartment.) These screws are designed for a single insertion, and removing them can cause damage to the screw posts. Be careful to not over-tighten on re-insertion.

Case repair

Cases that pull apart can be repaired by using 1.6mm x 18mm (20mm cut down) machine screws and nuts. The left case had two broken top screw posts; drilled right through including the hard clear top, fixed with screws and nuts. The right case had the clamping posts broken, so four 2.0mm x 20mm screw heads clamp on top, and the screws went into the original plastic posts after thread-tapping them. The battery cover did not fit, so two holes were recessed, giving an extra locking to the cover.



What's Inside the 622C Cases?

Many thanks to **Phil Weston** for providing the following excellent pics with notations:

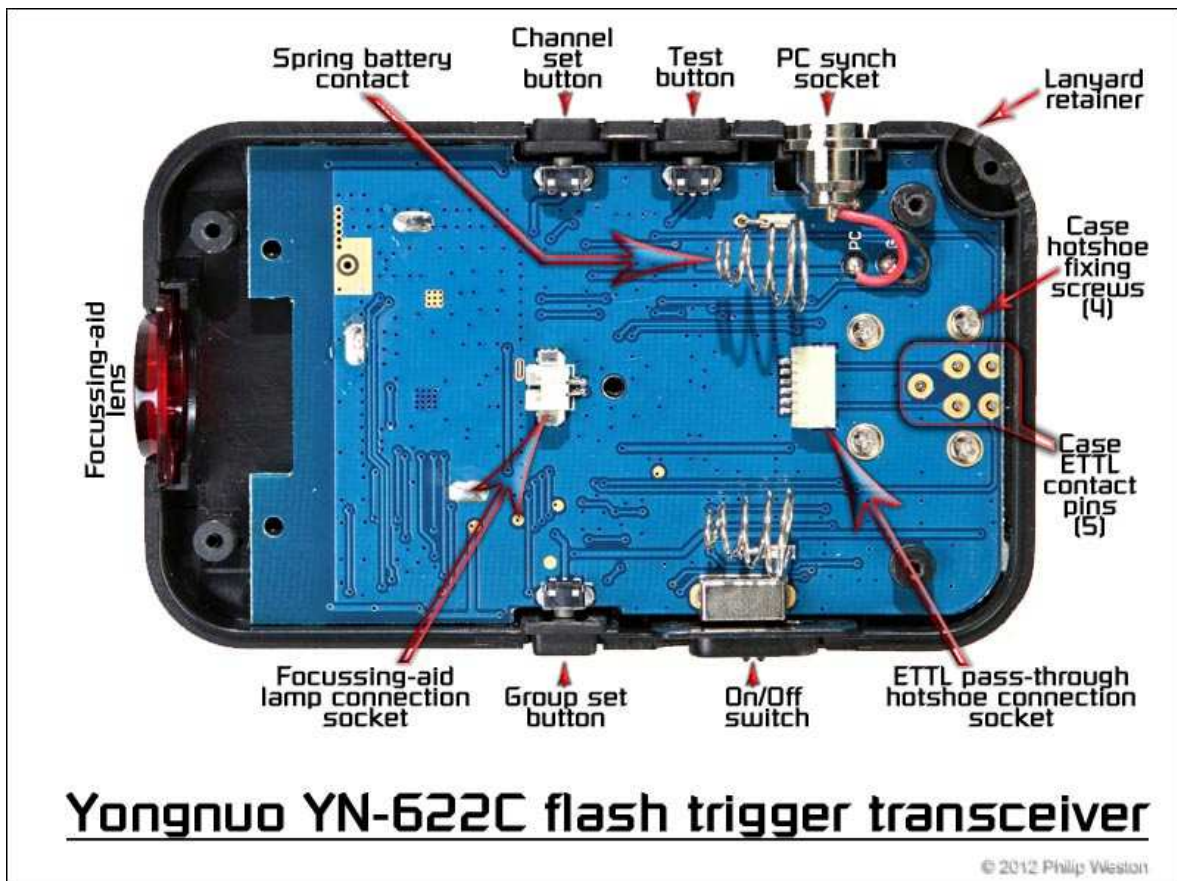



Yongnuo YN-622C-TX controller

for YN-622C flash trigger system

©2014 Philip Weston

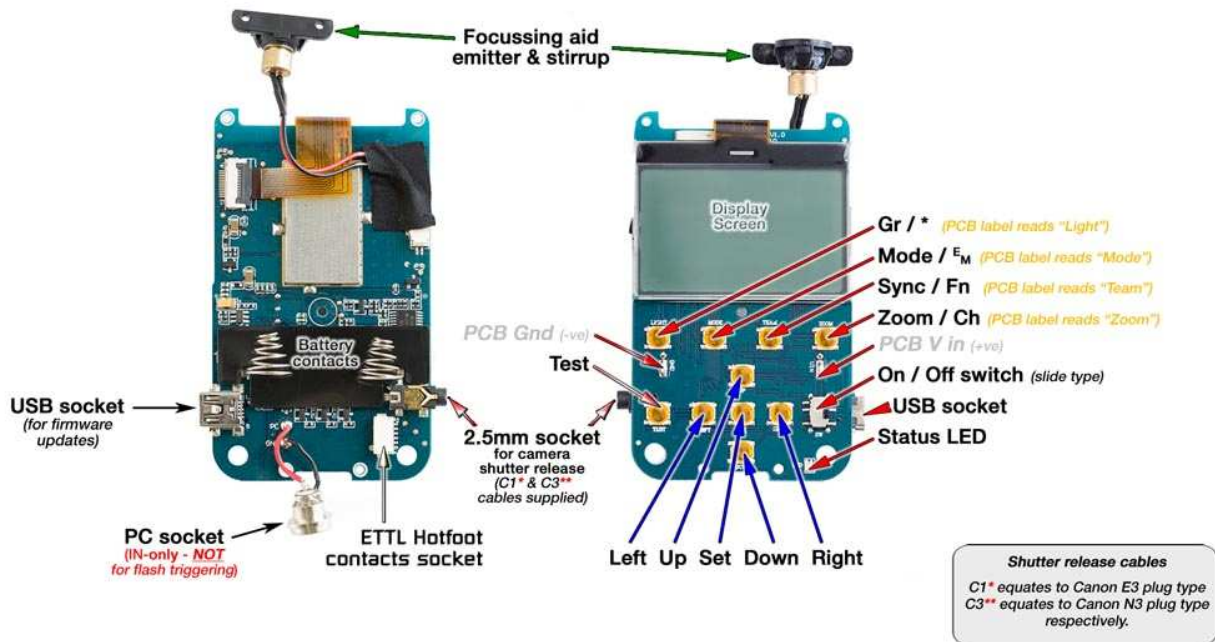

Yongnuo YN-622C-TX flash trigger transmitter

for use with YN-622c transceiver system. Printed circuit board 2014 v1.0. Data: 0210

©2014 Philip Weston



OTHER RESOURCES

Current version of this document

<https://docs.google.com/open?id=0B77OmmGlg0gMVfpgNkpBYXBHajA>

Deutsche translation of this document by J. Wahl

https://docs.google.com/open?id=0B_QoUj_xlYSNUUpQdnhFbE91LTA

User Manuals online:

622C: Full English/Chinese <http://www.yongnuoebay.com/sm/yn622cy.pdf>

English only <https://docs.google.com/open?id=0B77OmmGlg0gMYTNTWEhIOXZNYIU>

C-TX: Full English/Chinese http://yongnuo.com.cn/usermanual/pdf/YN622C-TX_UserManual.pdf

Or <https://drive.google.com/file/d/0B77OmmGlg0gMSHN6SE81Y3NwZEU>

YongNuo

Official Website (English): <http://www.hkyongnuo.com/e-aboutus.php>

622C product page: <http://www.hkyongnuo.com/e-detailly.php?ID=305>

622C-TX product page: <http://www.hkyongnuo.com/e-detailly.php?ID=348>

Driver & Software: http://yongnuo.com.cn/usermanual/pdf/YN_Trigger_Updater.zip

Firmware: http://yongnuo.com.cn/usermanual/pdf/YN622C-TX_FW_V1.01.zip

Ebay Online Store: <http://stores.ebay.com/hkyongnuophotoequipment>

Email Product Support: service@hkyongnuo.com

Large 622C thread on POTN:

<http://photography-on-the.net/forum/showthread.php?t=1212530>

Getting the Most from Speedlites

Pt 1 (10 pages), Syl Arena, Canon Europe

http://cpn.canon-europe.com/content/education/technical/getting_the_most_from_speedlites.do

Two excellent books:

Speedlites Handbook: Learning to Craft Light with Canon Speedlites, Syl Arena, Peachpit Press

Mastering Canon EOS Flash Photography, N K Guy, Rocky Nook

Dan Kinzie's video review:

<http://youtu.be/NTUuFGTHskY>

About Shutters and Syncs

<http://photography-on-the.net/forum/showthread.php?p=15603404#post15603404>

TOYUG

